



Safety instructions

VEGABAR 81, 82, 83, 86, 87

Intrinsic safety

TÜV 13 ATEX 131115 X

4 ... 20 mA

4 ... 20 mA/HART

4 ... 20 mA/HART SIL

Profibus PA

Foundation Fieldbus

Slave Sensor for electronic differential pressure measurement (SIL)

Additional current output



CE 0044



Document ID: 47679



VEGA

Contents

1	Area of applicability.....	4
2	General information.....	4
3	Technical data	5
4	Application conditions	12
5	Protection against static electricity	15
6	Use of an overvoltage arrester	15
7	Grounding.....	15
8	Impact and friction sparks	16
9	Material resistance	16
10	Mounting with external display unit VEGADIS 61/81.....	16
11	Installation/construction	16
12	Installation of the VEGABAR series 80 with separate housing	16

Supplementary documentation:

- Operating instructions VEGABAR 81, 82, 83, 86, 87
- Quick setup guide VEGABAR 81, 82, 83, 86, 87
- 47680 - EU type approval certificate TÜV 13 ATEX 131115 X
- 47246 - EU conformity declaration
- 48369 - SIL Safety Manual

Editing status: 2017-05-12

DE	Sicherheitshinweise für den Einsatz in explosionsgefährdeten Bereichen
EN	Safety instructions for the use in hazardous areas
FR	Consignes de sécurité pour une application en atmosphères explosibles
IT	Normative di sicurezza per l'impiego in luoghi con pericolo di esplosione
ES	Instrucciones de seguridad para el empleo en áreas con riesgo de explosión
PT	Normas de segurança para utilização em zonas sujeitas a explosão
NL	Veiligheidsaanwijzingen voor gebruik op plaatsen waar ontploffingsgevaar kan heersen
SV	Säkerhetsanvisningar för användning i explosionsfarliga områden
DA	Sikkerhedsforskrifter til anvendelse i explosionsfarlig atmosfære
FI	Turvallisuusohjeet räjähdysvaarallisissa tiloissa käyttöä varten
EL	Υποδείξεις ασφαλείας για τη χρησιμοποίηση σε περιοχές που υπάρχει κίνδυνος έκρηξης

DE	Die vorliegenden Sicherheitshinweise sind im Download unter www.vega.com standardmäßig in den Sprachen deutsch, englisch, französisch und spanisch verfügbar. Weitere EU-Landessprachen stellt VEGA nach Anforderungen zur Verfügung.
EN	These safety instructions are available as a standard feature in the download area under www.vega.com in the languages German, English, French and Spanish. Further EU languages will be made available by VEGA upon request.
FR	Les présentes consignes de sécurité sont disponibles au téléchargement sous www.vega.com en standard en allemand, en anglais, en français et en espagnol. VEGA met à disposition d'autres langues de l'Union Européenne selon les exigences.
ES	Las indicaciones de seguridad presentes están disponibles en la zona de descarga de www.vega.com de forma estándar en los idiomas inglés, francés y español. VEGA pone a disposición otros idiomas de la UE cuando son requeridos.

1 Area of applicability

These safety instructions apply to the pressurized transmitters VEGABAR B81/82/83/86/87.AC/U/O/H/T and VEGABAR B81/82/83/86/87.VC with integrated electronics Z (4 ... 20 mA), H (4 ... 20 mA/HART), A (4 ... 20 mA/HART with SIL qualification), P (Profibus PA), F (Foundation Fieldbus), S, T (differential pressure measurement) without supplementary electronics (X) according to EU type approval certificate TÜV 13 ATEX 131115 X Issue 00 (certificate number on the type label) and for all instruments with the number of the safety instruction (47679) on the type label.

2 General information

The pressure-based measuring instruments VEGABAR B8*.AC/U/O/H/T, VEGABAR B8*.VC are also used for pressure and level measurement in hazardous areas.

The measured products can also be combustible liquids, gases, mist or vapour.

The VEGABAR B8*.AC/U/O/H/T, VEGABAR B8*.VC consist of an electronics housing with integrated electronics module, a process connection element and a sensor, the pressure measuring cell with optionally connected chemical seal. As an option, the display and adjustment module can also be mounted.

The VEGABAR B8*.AC/U/O/H/T, VEGABAR B8*.VC are suitable for use in hazardous atmospheres of all combustible materials of explosion group IIA, IIB and IIC for applications requiring instruments of category 1G, category 1/2G or category 2G.

If the VEGABAR B8*.AC/U/O/H/T, VEGABAR B8*.VC are installed and operated in hazardous areas, the general Ex installation regulations EN 60079-14 as well as these safety instructions must be observed.

The operating instructions as well as the installation regulations and standards that apply for explosion protection of electrical systems must always be observed.

The installation of explosion-endangered systems must always be carried out by qualified personnel.

Category 1G instrument (EPL Ga instrument)

The VEGABAR B8*.AC/U/O/H/T, VEGABAR B8*.VC are installed in hazardous areas requiring instruments of category 1G.

Category 1/2G instrument (EPL Ga/Gb instrument)

The process connection element is installed in the separating wall, which separates areas in which instruments of category 2G or 1G are required. The electronics housing is installed in hazardous areas requiring instruments of category 2G. The sensor is installed in hazardous areas requiring instruments of category 1G.

Category 2G instrument (EPL Gb instrument)

The VEGABAR B8*.AC/U/O/H/T, VEGABAR B8*.VC are installed in hazardous areas requiring instruments of category 2G.

Ignition protection label:

II 1G, 1/2G, 2G Ex ia IIC T6 ... T1 Ga, Ga/Gb, Gb

3 Technical data

VEGABAR B8*.AC/U/O/H/T, VEGABAR B8*.VC with integrated electronics Z (4 ... 20 mA), H (4 ... 20 mA/HART) or A (4 ... 20 mA/HART with SIL qualification), version with single chamber housing A, K, V or 8

Supply and signal circuit: (terminals 1[+], 2[-] in the "Ex-" electronics compartment or plug connection) In ignition protection type intrinsic safety Ex ia IIC/IIB
Only for connection to a certified, intrinsically safe circuit.

Maximum values:

- $U_i = 30 \text{ V}$
- $I_i = 131 \text{ mA}$
- $P_i = 983 \text{ mW}$

The effective internal capacitance C_i is negligibly small.

In the version with permanently mounted connection cable, $C_{i \text{ wire/wire}} = 150 \text{ pF/m}$ and $C_{i \text{ wire/screen}} = 270 \text{ pF/m}$ must be taken into account.

The effective inner inductance L_i is $L_i \leq 5 \text{ } \mu\text{H}$. In the version with permanently mounted connection cable, $L_i = 0.62 \text{ } \mu\text{H/m}$ must also be taken into account.

VEGABAR B8*.AC/U/O/H/T, VEGABAR B8*.VC with integrated electronics Z (4 ... 20 mA), H (4 ... 20 mA/HART) or A (4 ... 20 mA/HART with SIL qualification), version with double chamber housing D, W or R

Power supply and signal circuit: (terminal 1[+], 2[-] in the "Ex-" connection compartment) In ignition protection type intrinsic safety Ex ia IIC/IIB
Only for connection to a certified, intrinsically safe circuit.

Maximum values:

- $U_i = 30 \text{ V}$
- $I_i = 131 \text{ mA}$
- $P_i = 983 \text{ mW}$

The effective internal capacitance C_i is negligibly small.

In the version with permanently mounted connection cable, $C_{i \text{ wire/wire}} = 150 \text{ pF/m}$ and $C_{i \text{ wire/screen}} = 270 \text{ pF/m}$ must be taken into account.

The effective inner inductance L_i with the double chamber version is $L_i \leq 10 \text{ } \mu\text{H}$. In the version with permanently mounted connection cable, $L_i = 0.62 \text{ } \mu\text{H/m}$ must also be taken into account.

VEGABAR B8*.AC/U/O/H/T, VEGABAR B8*.VC with integrated electronics Z (4 ... 20 mA), H (4 ... 20 mA/HART) or A (4 ... 20 mA/HART with SIL qualification)

Indicating and adjustment circuit: (terminals 5, 6, 7, 8)¹⁾²⁾³⁾

In ignition protection type intrinsic safety Ex ia IIC

For connection to the intrinsically safe circuit of the corresponding external display unit VEGADIS 61/81 (PTB 02 ATEX 2136 X) or for connection of a VEGABAR B80 with integrated electronics S or T for differential pressure measurement.

The rules for the interconnection of intrinsically safe circuits between VEGABAR B8*.AC/U/O/H/T, VEGABAR B8*.VC and the external indicating unit VEGADIS 61/81 or VEGABAR B8* with electronics S or T are fulfilled, provided that the total inductance and total capacitance of the connection cable between VEGABAR B8*.AC/U/O/H/T, VEGABAR B8*.VC and the external indicating unit VEGADIS 61/81 or VEGABAR B8* with electronics S or T $L_{\text{cable}} = 330 \mu\text{H}$ and $C_{\text{cable}} = 1.98 \mu\text{F}$ are not exceeded.

When using the delivered VEGA connection cable between VEGABAR B8*.AC/U/O/H/T, VEGABAR B8*.VC and the external indicating unit VEGADIS 61/81 or VEGABAR B8* with electronics S or T, the following listed cable inductances L_i and cable capacitances C_i must be taken into account with a cable length $\geq 50 \text{ m}$.

- $L_i = 0.62 \mu\text{H/m}$
- $C_{i \text{ wire/wire}} = 150 \text{ pF/m}$
- $C_{i \text{ wire/screen}} = 270 \text{ pF/m}$

Intrinsically safe circuit for the display and adjustment module

VEGABAR B8*.AC/U/O/H/T, VEGABAR B8*.VC with integrated electronics Z (4 ... 20 mA), H (4 ... 20 mA/HART) or A (4 ... 20 mA/HART with SIL qualification), version with single chamber housing A, K, V or 8

Circuit for the display and adjustment module: (spring contacts in the "Ex-i" electronics compartment)

In ignition protection type intrinsic safety Ex ia IIC

Only for connection to the display and adjustment module PLICSCOM or VEGACONNECT (PTB 07 ATEX 2013 X).

1) In the "Ex-i" electronics compartment with VEGABAR in version with single chamber housing A, K, V or 8.
 2) In the "Ex-i" connection compartment with VEGABAR in version with double chamber housing D, W or R.
 3) Additional plug connection with VEGABAR in version with double chamber housing D, W, R and housing version/protection P (with M12 x 1 for VEGADIS).

VEGABAR B8*.AC/U/O/H/T, VEGABAR B8*.VC with integrated electronics Z (4 ... 20 mA), H (4 ... 20 mA/HART) or A (4 ... 20 mA/HART with SIL qualification), version with double chamber housing D, W or R

Circuit for the display and adjustment module: (spring contacts in the "Ex-i" connection compartment)

In ignition protection type intrinsic safety Ex ia IIC
Only for connection to the display and adjustment module PLICSCOM or VEGACONNECT (PTB 07 ATEX 2013 X).

or

Circuit for the display and adjustment module: (spring contacts in the "Ex-i" electronics compartment)

In ignition protection type intrinsic safety Ex ia IIC
Only for connection to the display and adjustment module PLICSCOM or VEGACONNECT (PTB 07 ATEX 2013 X).

In the double chamber version, the display and adjustment module PLICSCOM or VEGACONNECT must only be equipped in the connection compartment, if there is no external VEGA display unit VEGADIS 61/81 or VEGABAR B80 with electronics S, T connected.

VEGABAR B8*.AC/U/O/H/T, VEGABAR B8*.VC with integrated electronics Z (4 ... 20 mA), H (4 ... 20 mA/HART) or A (4 ... 20 mA/HART with SIL qualification), version with double chamber housing D, W or R with housing version/protection P (with M12 x 1 for VEGADIS)

Circuit for the display and adjustment module: (spring contacts in the "Ex-i" connection compartment)

In ignition protection type intrinsic safety Ex ia IIC
Only for connection to the display and adjustment module PLICSCOM or VEGACONNECT (PTB 07 ATEX 2013 X).

In the double chamber version, the display and adjustment module PLICSCOM or VEGACONNECT must only be equipped in the connection compartment, if there is no external VEGA display unit VEGADIS 61/81 or VEGABAR B80 with electronics S, T connected.

VEGABAR B8*.AC/U/O/H/T, VEGABAR B8*.VC with integrated electronics P (Profibus PA), F (Foundation Fieldbus), version with single chamber housing A, K, V or 8

Supply and signal circuit: (terminals 1[+], 2[-] in the "Ex-i" electronics compartment or plug connection) In ignition protection type intrinsic safety Ex ia IIC/IIB Only for connection to a certified, intrinsically safe circuit.

Maximum values:

- $U_i = 17.5 \text{ V}$
- $I_i = 500 \text{ mA}$
- $P_i = 5.5 \text{ W}$

The instrument is suitable for connection to a Fieldbus system according to the FISCO model (EN 60079-11), e.g. Profibus PA.

or

- $U_i = 24 \text{ V}$
- $I_i = 250 \text{ mA}$
- $P_i = 1.2 \text{ W}$

The effective internal capacitance C_i is negligibly small. In the version with permanently mounted connection cable, $C_{i \text{ wire/wire}} = 150 \text{ pF/m}$ and $C_{i \text{ wire/screen}} = 270 \text{ pF/m}$ must be taken into account.

The effective internal inductance L_i is negligibly small.

In the version with fix mounted connection cable, $L_i = 0.62 \text{ } \mu\text{H/m}$ must be taken into consideration.

VEGABAR B8*.AC/U/O/H/T, VEGABAR B8*.VC with integrated electronics P (Profibus PA), F (Foundation Fieldbus), version with double chamber housing D, W or R

Power supply and signal circuit: (terminal 1[+], 2[-] in the "Ex-i" connection compartment)

In ignition protection type intrinsic safety Ex ia IIC/IIB for instruments of category 1G or 1/2G and Ex ia IIC/IIB resp. Ex ib IIC/IIB for instruments of category 2G.

Only for connection to a certified, intrinsically safe circuit.

Maximum values:

- $U_i = 17.5 \text{ V}$
- $I_i = 500 \text{ mA}$
- $P_i = 5.5 \text{ W}$

The instrument is suitable for connection to a Fieldbus system according to the FISCO model (EN 60079-11), e.g. Profibus PA.

or

- $U_i = 24 \text{ V}$
- $I_i = 250 \text{ mA}$
- $P_i = 1.2 \text{ W}$

The effective internal capacitance C_i is negligibly small.

In the version with permanently mounted connection cable, $C_{i \text{ wire/wire}} = 150 \text{ pF/m}$ and $C_{i \text{ wire/screen}} = 270 \text{ pF/m}$ must be taken into account.

The effective internal inductance is $L_i \leq 5 \text{ }\mu\text{H}$.

In the version with fix mounted connection cable, also $L_i = 0.62 \text{ }\mu\text{H/m}$ must be taken into consideration.

VEGABAR B8*.AC/U/O/H/T, VEGABAR B8*.VC with integrated electronics P (Profibus PA), F (Foundation Fieldbus)

Indicating and adjustment circuit: (terminals 5, 6, 7, 8)⁴⁾⁵⁾⁶⁾

In ignition protection type intrinsic safety Ex ia IIC

For connection to the intrinsically safe circuit of the corresponding external display unit VEGADIS 61/81 (PTB 02 ATEX 2136 X) or for connection of a VEGABAR B80 with integrated electronics S or T for differential pressure measurement.

The rules for the interconnection of intrinsically safe circuits between VEGABAR B8*.AC/U/O/H/T, VEGABAR B8*.VC and the external indicating unit VEGADIS 61/81 or VEGABAR B8* with electronics S or T are fulfilled, provided that the total inductance and total capacitance of the connection cable between VEGABAR B8*.AC/U/O/H/T, VEGABAR B8*.VC and the external indicating unit VEGADIS 61/81 or VEGABAR B8* with electronics S or T $L_{\text{cable}} = 212 \mu\text{H}$ and $C_{\text{cable}} = 1.98 \mu\text{F}$ are not exceeded.

When using the delivered VEGA connection cable between VEGABAR B8*.AC/U/O/H/T, VEGABAR B8*.VC and the external indicating unit VEGADIS 61/81 or VEGABAR B8* with electronics S or T, the following listed cable inductances L_i and cable capacitances C_i must be taken into account with a cable length $\geq 50 \text{ m}$.

- $L_i = 0.62 \mu\text{H/m}$
- $C_{i \text{ wire/wire}} = 150 \text{ pF/m}$
- $C_{i \text{ wire/screen}} = 270 \text{ pF/m}$

Intrinsically safe circuit for the display and adjustment module

VEGABAR B8*.AC/U/O/H/T, VEGABAR B8*.VC with integrated electronics P (Profibus PA), F (Foundation Fieldbus), version with single chamber housing A, K, V or 8

Circuit for the display and adjustment module: (spring contacts in the "Ex-i" electronics compartment)

In ignition protection type intrinsic safety Ex ia IIC

Only for connection to the display and adjustment module PLICSCOM or VEGACONNECT (PTB 07 ATEX 2013 X).

VEGABAR B8*.AC/U/O/H/T, VEGABAR B8*.VC with integrated electronics P (Profibus PA), F (Foundation Fieldbus), version with double chamber housing D, W or R

Circuit for the display and adjustment module: (spring contacts in the "Ex-i" connection compartment)

In ignition protection type intrinsic safety Ex ia IIC

Only for connection to the display and adjustment module PLICSCOM or VEGACONNECT (PTB 07 ATEX 2013 X).

or

- 4) In the "Ex-i" electronics compartment with VEGABAR in version with single chamber housing A, K, V or 8.
- 5) In the "Ex-i" connection compartment with VEGABAR in version with double chamber housing D, W or R.
- 6) Additional plug connection with VEGABAR in version with double chamber housing D, W, R and housing version/protection P (with M12 x 1 for VEGADIS).

Circuit for the display and adjustment module: (spring contacts in the "Ex-i" electronics compartment)

In ignition protection type intrinsic safety Ex ia IIC

Only for connection to the display and adjustment module PLICSCOM or VEGACONNECT (PTB 07 ATEX 2013 X).

In the double chamber version, the display and adjustment module PLICSCOM or VEGACONNECT must only be equipped in the connection compartment, if there is no external VEGA display unit VEGADIS 61/81 or VEGABAR B80 with electronics S, T connected.

VEGABAR B8*.AC/U/O/H/T, VEGABAR B8*.VC with integrated electronics Z (4 ... 20 mA), H (4 ... 20 mA/HART) or A (4 ... 20 mA/HART with SIL qualification), version with double chamber housing D, W or R with housing version/protection P (with M12 x 1 for VEGADIS)

Circuit for the display and adjustment module: (spring contacts in the "Ex-i" connection compartment)

In ignition protection type intrinsic safety Ex ia IIC

Only for connection to the display and adjustment module PLICSCOM or VEGACONNECT (PTB 07 ATEX 2013 X).

In the double chamber version, the display and adjustment module PLICSCOM or VEGACONNECT must only be equipped in the connection compartment, if there is no external VEGA display unit VEGADIS 61/81 or VEGABAR B80 with electronics S, T connected.

VEGABAR B8*.AC/U/O/H/T, VEGABAR B8*.VC with integrated electronics S or T, only version with single chamber housing

Power supply and signal circuit: (terminals 5, 6, 7, 8 in the electronics compartment)

In ignition protection type intrinsic safety Ex ia IIC

For connection to the intrinsically safe circuit of a VEGABAR B8*.C***** with integrated electronics H, A, P, F for differential pressure measurement.

The rules for the interconnection of intrinsically safe circuits between VEGABAR B80 with electronics S or T and VEGABAR B8*.C***** with electronics H, A, P or F are fulfilled, provided that the total inductance and total capacitance of the connection cable between VEGABAR B8*.C***** and VEGABAR B8* with electronics S or T, $L_{\text{cable}} = 330 \mu\text{H}$ and $C_{\text{cable}} = 2.00 \mu\text{F}$, is not exceeded.

When using the delivered VEGA connection cable between VEGABAR B8*.AC/U/O/H/T, VEGABAR B8*.VC and the external indicating unit VEGADIS 61/81 or VEGABAR B8* with electronics S or T, the following listed cable inductances L_i and cable capacitances C_i must be taken into account with a cable length ≥ 50 m.

- $L_i = 0.62 \mu\text{H/m}$
- $C_{i \text{ wire/wire}} = 150 \text{ pF/m}$
- $C_{i \text{ wire/screen}} = 270 \text{ pF/m}$

VEGABAR B8*.AC/U/O/H/T, VEGABAR B8*.VC Version with separate cable outlet (all electronics)

Circuit between sensor unit and external electronics (terminal 1- yellow, terminal 2 - white, terminal 3 - red, terminal 4 - black)	In ignition protection type intrinsic safety Ex ia IIC With VEGABAR B8*.AC in the version with fix mounted cable on the sensor unit and external electronics, the supplied cable between the external housing and the sensor unit must not exceed a length of 180 m.
---	---

The intrinsically safe circuits are electrically separated from parts which can be grounded.

The metallic parts of VEGABAR B8*.AC/U/O/H/T, VEGABAR B8*.VC are electrically connected with the earth terminals.

For applications requiring instruments of category 1G or 1/2G, the intrinsically safe power supply and signal circuit must correspond to protection class ia.

For applications requiring instruments of category 1G or 1/2G the VEGABAR B8*.AC/U/O/H/T, VEGABAR B8*.VC is preferably connected to appropriate equipment with galvanically isolated, intrinsically safe circuits.

4 Application conditions

VEGABAR B8*.AC/U/O/H/T, VEGABAR B8*.VC with integrated electronics Z (4 ... 20 mA), H (4 ... 20 mA/HART) or A (4 ... 20 mA/HART with SIL qualification), S, T (electronic differential pressure measurement), P (Profibus PA), F (Foundation Fieldbus)

The max. permissible ambient temperatures depending on the temperature classes are specified in the following tables.

Category 1G instrument (EPL Ga instrument)

Temperature class	Ambient temperature on the sensor and electronics
T6	-20 ... +23 °C
T5, T4, T3, T2, T1	-20 ... +60 °C

For applications requiring instruments of category 1G (EPL Ga instruments), the process pressure of the media must be between 0.8 ... 1.1 bar. With the stated permissible ambient temperatures, the 80 % consideration of section 6.4.2/EN 1127-1 is taken into account. The application conditions during operation in areas with no explosive mixtures are stated in the manufacturer information (operating instructions).

Category 1/2G instrument (EPL Ga/Gb instrument)

Temperature class	Ambient temperature on the electronics (Zone 1)	Product temperature range (sensor, zone 0)
T6	-50 ... +39 °C	-20 ... +23 °C
T5, T4, T3, T2, T1	-50 ... +70 °C	-20 ... +60 °C

For applications requiring instruments of category 1/2G (EPL Ga/Gb instrument) the process pressure of the media must be between 0.8 ... 1.1 bar. The 80 % consideration of Sect. 6.4.2/EN 1127-1 is taken into account with the permissible ambient temperatures. If the VEGABAR B8*.AC/U/O/H/T, VEGABAR B8*.VC are operated at temperatures higher than those specified in the above table, please make sure by means of appropriate measures that there is no danger of ignition from the hot surfaces. The maximum temperature on the electronics/housing should not exceed the values

stated in the above table. The application conditions in areas without hazardous mixtures are specified in the manufacturer information (operating instructions).

Category 2G instrument (EPL Gb instrument), VEGABAR 82, VEGABAR 83 with METEC measuring cell

Temperature class	Ambient temperature on the electronics (Zone 1)	Product temperature range (sensor, zone 1)
T6	-50 ... +39 °C	-50 ... +39 °C
T5	-50 ... +70 °C	-50 ... +100 °C
T4	-50 ... +50 °C	-50 ... +135 °C
T3, T2, T1	-50 ... +50 °C	-50 ... +200 °C

Category 2G instrument (EPL Gb instrument), VEGABAR 83 version with piezoresistive/strain gauge measuring cell, version without cooling element

Temperature class	Ambient temperature on the electronics (Zone 1)	Product temperature range (sensor, zone 1)
T6	-50 ... +39 °C	-50 ... +39 °C
T5	-50 ... +70 °C	-50 ... +85 °C
T4	-50 ... +40 °C	-50 ... +105 °C
T4, T3, T2, T1	-50 ... +30 °C	-50 ... +120 °C

Category 2G instrument (EPL Gb instrument), VEGABAR 81, VEGABAR 83 version with piezoresistive/strain gauge measuring cell, version with cooling element

Temperature class	Ambient temperature on the electronics (Zone 1)	Product temperature range (sensor, zone 1)
T6	-50 ... +39 °C	-50 ... +39 °C
T5	-50 ... +70 °C	-50 ... +85 °C
T4	-50 ... +50 °C	-50 ... +120 °C
T3, T2, T1	-50 ... +40 °C	-50 ... +150 °C

If the VEGABAR B8*.AC/U/O/H/T, VEGABAR B8*.VC are operated at temperatures higher than those specified in the above table, please make sure through appropriate measures that there is no danger of ignition from the hot surfaces. The max. permissible temperature on the electronics/housing should not exceed the values specified in the above table. The application conditions during operation with no explosive mixtures present are stated in the manufacturer information (operating instructions).

Temperature derating

VEGABAR 82, version process temperature +130 °C

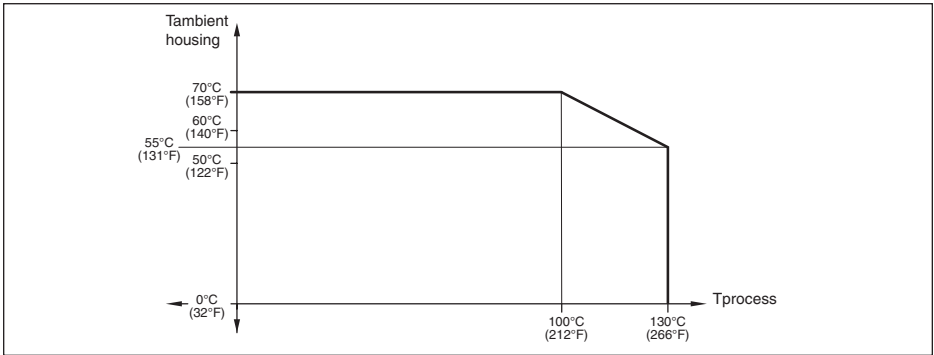

VEGABAR 82, version process temperature +150 °C

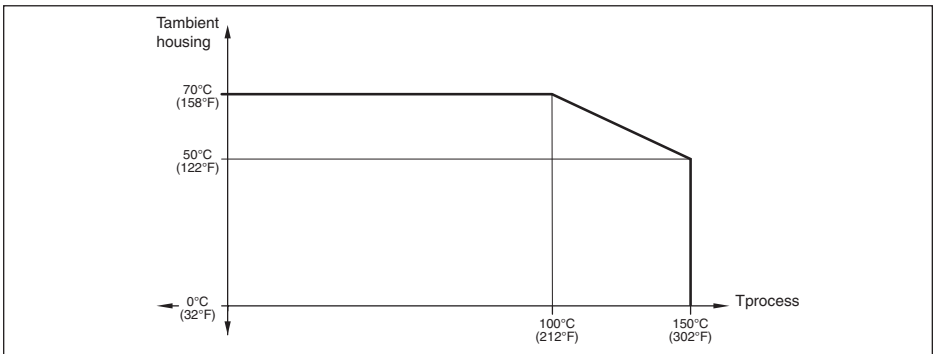

VEGABAR 81, VEGABAR 83

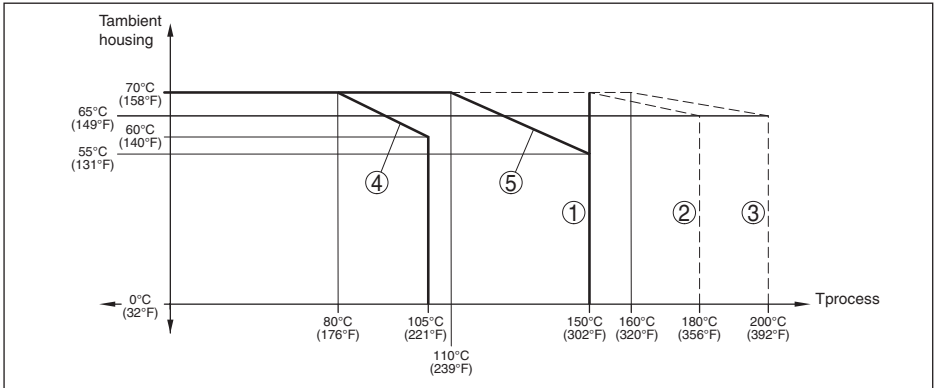

- 1 Version: METEC measuring cell, process temperature max. 150 °C
- 2 Version: METEC measuring cell, process temperature max. 180 °C
- 3 Version: METEC measuring cell, process temperature max. 200 °C
- 4 Version: Piezoresistive/strain gauge measuring cell, without cooling element
- 5 Version: Piezoresistive/strain gauge measuring cell, with cooling element

The temperature ranges for operation specified in the operating instruction must not be exceeded.

5 Protection against static electricity

The VEGABAR B8*.AC/U/O/H/T, VEGABAR B8*.VC in versions with electrostatically chargeable plastic parts, such as e.g. plastic housing, metal housing with inspection window, with plastic coated sensors, suspension cable or suspension hose, distance tube or connection cable with the separated version, a caution label points out the safety measures that must be taken with regard to electrostatic charges during operation.

**WARNING- DO NOT OPEN WHEN AN
EXPLOSIVE ATMOSPHERE IS PRESENT**

Caution: Plastic parts! Danger of electrostatic charging!

- Avoid friction
- No dry cleaning
- Do not mount in areas with flowing, non-conductive products

6 Use of an overvoltage arrester

If necessary, a suitable overvoltage arrester can be connected in front of the VEGABAR B8*.AC/U/O/H/T, VEGABAR B8*.VC.

When used as category 1G or 1/2G instrument, as far as necessary analogue, a suitable overvoltage arrester must be connected in front as protection against voltage surges according to EN 60079-14.

7 Grounding

In order to avoid the danger of electrostatic charging of the metallic parts, the VEGABAR B8*.AC/U/O/H/T, VEGABAR B8*.VC must be electrostatically connected to the local potential equalisation (transfer resistance $\leq 1 \text{ M}\Omega$), e.g. via the ground terminal, when used as category 1G or 1/2G

instruments.

8 Impact and friction sparks

When used as category 1G or 1/2G instruments, the VEGABAR B8*.AC/U/O/H/T, VEGABAR B8*.VC in aluminium/titanium versions must be mounted in such a way that sparks from impact and friction between aluminium/titanium and steel (except stainless steel, if the presence of rust particles can be excluded) cannot occur.

9 Material resistance

For applications requiring instruments of category 1G or category 1/2G the VEGABAR B8*.AC/U/O/H/T, VEGABAR B8*.VC must only be used in products against which the wetted materials are sufficiently resistant.

10 Mounting with external display unit VEGADIS 61/81

The intrinsically safe signal circuit between VEGABAR B8*.AC/U/O/H/T, VEGABAR B8*.VC and the external indicating unit VEGADIS 61/81 should be set up without grounding. The required insulation voltage is > 500 V AC. When using the VEGA connection cable included with the delivery, this requirement is fulfilled. If grounding of the cable screen is required, it must be carried out according to EN 60079-14.

11 Installation/construction

The VEGABAR B8*.AC/U/O/H/T, VEGABAR B8*.VC have to be mounted such that the sensor is effectively secured against touching the vessel wall, under consideration of other vessel installations and flow conditions in the vessel. This applies especially to suspension pressure transmitters and versions with distance tube lengths over 3 m.

12 Installation of the VEGABAR series 80 with separate housing

With the version with separate housing of the pressure transmitter VEGABAR B8*.AC/U/O/H/T, VEGABAR B8*.VC, the potential equalization must be provided in the complete range of the connection cable between electronics housing and transmitter housing.



47679-EN-170512

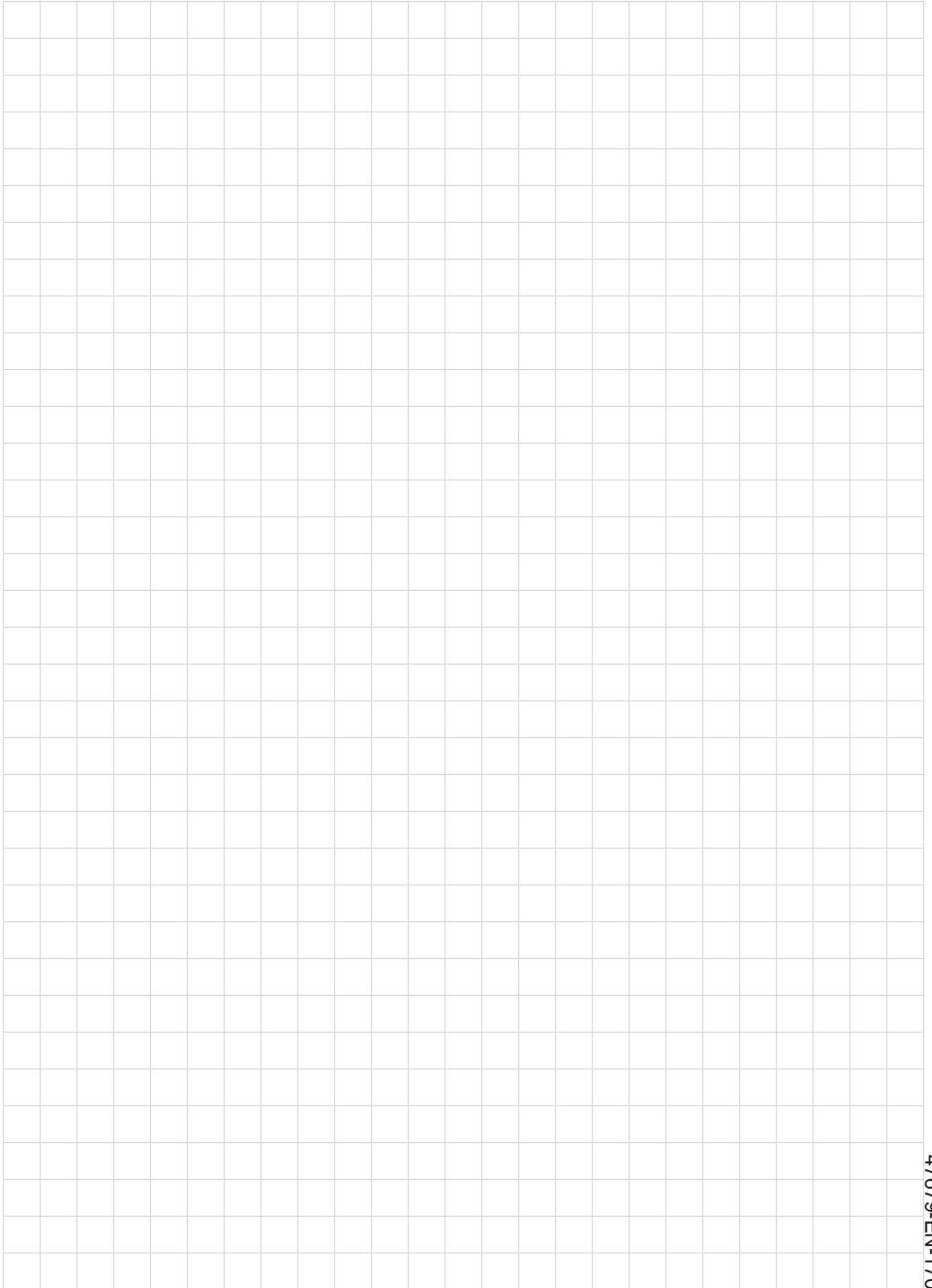



Printing date:

VEGA

All statements concerning scope of delivery, application, practical use and operating conditions of the sensors and processing systems correspond to the information available at the time of printing.

Subject to change without prior notice

© VEGA Grieshaber KG, Schiltach/Germany 2017



47679-EN-170512

VEGA Grieshaber KG
Am Hohenstein 113
77761 Schiltach
Germany

Phone +49 7836 50-0
Fax +49 7836 50-201
E-mail: info.de@vega.com
www.vega.com