

Options for ABB drives

User's manual

FPTC-01 thermistor protection module (option +L536)
for ACS880 drives



Power and productivity
for a better world™



List of related manuals

Drive hardware manuals

Code (EN)

<i>ACS880-01 hardware manual</i>	3AUA0000078093
<i>ACS880-04 hardware manual</i>	3AUA0000128301
<i>ACS880-04 drive module packages hardware manual</i>	3AUA0000138495
<i>ACS880-11 hardware manual</i>	3AXD50000045932
<i>ACS880-31 hardware manual</i>	3AXD50000045933
<i>ACS880-14 and -34 hardware manual</i>	3AXD50000022021
<i>ACS880-04XT (500 to 1200 kW) hardware manual</i>	3AXD50000025169
<i>ACS880-04F drive modules hardware manual</i>	3AXD50000034664
<i>ACS880-M04 hardware manual</i>	3AXD50000028613
<i>ACS880-07 (45 to 630 kW) hardware manual</i>	3AUA0000105718
<i>ACS880-07 (560 to 2800 kW) hardware manual</i>	3AUA0000143261
<i>ACS880-17 (160 to 3200 kW) hardware manual</i>	3AXD50000020436
<i>ACS880-17 (45...400 kW) hardware manual</i>	3AXD50000035158
<i>ACS880-37 (160 to 3200 kW) hardware manual</i>	3AXD50000020437
<i>ACS880-37 (45...400 kW) hardware manual</i>	3AXD50000035159
<i>ACS880-104 inverter modules hardware manual</i>	3AUA0000104271
<i>ACS880-104LC inverter modules hardware manual</i>	3AXD50000045610
<i>ACS880-107 inverter units hardware manual</i>	3AUA0000102519

Drive firmware manuals

<i>ACS880 primary control program firmware manual</i>	3AUA0000085967
---	--------------------------------

Option manuals and guides

<i>FSO-12 safety functions module user's manual</i>	3AXD50000015612
<i>FSO-21 safety functions module user's manual</i>	3AXD50000015614
<i>FSE-31 pulse encoder interface module user's manual</i>	3AXD50000016597
<i>FPTC-01 thermistor protection module (option +L536) user's manual</i>	3AXD50000027750

Manuals and quick guides for I/O extension modules, fieldbus adapters, etc.

Drive PC tool manuals

<i>Drive composer start-up and maintenance PC tool user's manual</i>	3AUA0000094606
--	--------------------------------

General safety guides

<i>Functional safety; Technical guide No. 10</i>	3AUA0000048753
<i>Safety and functional safety; A general guide</i>	1SFC001008B0201
<i>ABB Safety information and solutions</i>	www.abb.com/safety
<i>Potentially explosive atmospheres. The basics you need to know about motors and drives</i>	3AUA0000037223

You can find manuals and other product documents in PDF format on the Internet. See section [Document library on the Internet](#) on the inside of the back cover. For manuals not available in the Document library, contact your local ABB representative.

User's manual

**FPTC-01 thermistor protection module
(option +L536) for ACS880 drives**

Table of contents



1. Safety



5. Mechanical installation



6. Electrical installation



8. Start-up and acceptance test



Table of contents

1. Safety

Contents this chapter	9
Use of warnings	9
Safety in installation and maintenance	10
Other warnings	11

2. Introduction to the manual

Contents of this chapter	13
Applicability	13
Compatibility	14
Target audience	15
Contents of the manual	16
Related documents	16
Terms and abbreviations	17
Exclusion of liability	20



3. Hardware description

Contents of this chapter	21
Product overview	21
Operation basics	22
XFLT input (Fault)	22
XWRN input (Warning)	22
Markings	25
FPTC-02 module	25
Type designation label	25
ATEX markings	26
Drive	27
Option +Q971	27
SMT function	28

4. Option description and instructions

Contents of this chapter	29
--------------------------------	----

6 Table of contents

ACS880-01/04/04XT/04F/M04/11/31/14/34/104 drives and modules	30
Cabinet-built drives	30
The ATEX-certified Safe disconnection function	31
Resetting the safety function	32
Indications of the safety function	33
Switching frequency limitation	34
Fault reaction function	35
FPTC-02 module	35
STO function in the drive/inverter modules	35
FSO module	35

5. Mechanical installation

Contents of this chapter	37
 Necessary tools and instructions	37
Unpacking and examining the delivery	37
Installing the module	38

6. Electrical installation

Contents of this chapter	41
Warnings	41
Necessary tools and instructions	41
General cabling instructions	42
Terminal designations	43
Wiring	44
Wiring example 1	45
Wiring example 2	46
Wiring example 3	47
Wiring example 4	48
Wiring example 5	49

7. Parameter settings

Contents of this chapter	51
Drive/inverter	51
Other recommended settings	54
FSO module	55
General parameters	56

Parameters related to the STO function	58
Parameters related to the SSE function	61
FSE module and safety pulse encoder parameters	62
Additional notes	64
Mechanical brake control	64

8. Start-up and acceptance test

Contents of this chapter	65
Before you start	65
Acceptance test	66

9. Fault tracing

Contents of this chapter	69
Reporting failures	69
FPTC-02 module replacement	69
Fault and warning messages	70
LEDs	72



10. Maintenance

Contents of this chapter	73
Maintenance	73
Proof test interval	74
Competence	75
Residual risk	75
Intentional misuse	75
Decommissioning	75

11. Technical data

Contents of this chapter	77
Dimension drawing	78
Isolation areas	79
Connections	80
Motor thermistor connection	80
STO output connection	80
Ambient conditions	80
Safety data	81
Safety block diagrams	83

Response times	84
Relevant failure modes	85
General rules, notes and definitions	86
Validation of the safety functions	86
Validation procedure	86
Acceptance test reports	87
Competence	87
Ambient conditions	87
Reporting problems and failures related to safety functions	87
Related standards and directives	88
Compliance with the European Machinery Directive	89
Compliance with the European ATEX Directive	89
ATEX certificate	94
TÜV Nord certificate	97



Further information

Product and service inquiries	99
Product training	99
Providing feedback on ABB manuals	99
Document library on the Internet	99

1

Safety

Contents this chapter

The chapter contains the warning symbols used in this manual and the safety instructions which you must obey when you install or connect an option module to a drive. If you ignore the safety instructions, injury, death or damage can occur. Read this chapter before you start the installation.



Use of warnings

Warnings tell you about conditions which can cause injury or death, or damage to the equipment. They also tell you how to prevent the danger. The manual uses these warning symbols:



Electricity warning tells you about hazards from electricity which can cause injury or death, or damage to the equipment.



General warning tells you about conditions, other than those caused by electricity, which can cause injury or death, or damage to the equipment.

Safety in installation and maintenance

These instructions are for all who install or connect an option module to a drive and need to open its front cover or door to do the work.



WARNING! Obey these instructions. If you ignore them, injury or death, or damage to the equipment can occur.



- If you are not a qualified electrician, do not do installation or maintenance work.
 - Disconnect the drive from all possible power sources. After you have disconnected the drive, always wait for 5 minutes to let the intermediate circuit capacitors discharge before you continue.
 - Disconnect all dangerous voltages connected to other connectors or parts in reach. For example, it is possible that 230 V AC is connected from outside to a relay output of the drive.
 - Always use a multimeter to make sure that there are no parts under voltage in reach. The impedance of the multimeter must be at least 1 Mohm.
-

Other warnings



WARNING! The Safe torque off (STO) feature of ACS880 drives cannot prevent the intermediate DC current from flowing through, and heating up, the motor in case a short circuit occurs in the output stage of the drive. The supplier must take this into account when planning the protection of the installation.



WARNING! ACS880 cabinet-built drives: Never connect, test or measure a drive based on the diagrams of this manual. Each delivery is unique. Before starting the work on the electric circuits of a drive, always refer to the delivery-specific circuit diagrams.





2

Introduction to the manual

Contents of this chapter

This chapter gives basic information on the manual.

Applicability

This manual applies to the FPTC-01 module and to the Safe motor temperature safety function which uses the FPTC-01 module (option +L536).

Compatibility

The FPTC-01 module is compatible with:

- ACS880-01/04/04XT/04F/M04/11/31/14/34/104 drives and modules
 - ACS880-07/17/37 cabinet-built single drives
 - ACS880 multidrives
 - FSO-12 safety functions module
 - FSO-21 safety functions module
 - ACS880 primary control program version 2.10 or later
 - Other control programs: Check the compatibility with your local ABB representative.
 - ACS880 liquid-cooled drives, modules and multidrives: Check the compatibility with your local ABB representative.
-

Target audience

This manual is intended for people who plan the installation, install, start up, use and service the option module. Before you do work on the module, read this manual and the applicable drive manual that contains the hardware and safety instructions for the product in question.

You are expected to know the fundamentals of electricity, wiring, electrical components and electrical schematic symbols and Ex regulations.

The manual is written for readers worldwide. Both SI and imperial units are shown.

Contents of the manual

The manual consists of these chapters:

- *Safety* contains the safety instructions which you must obey when you install the module.
- *Introduction to the manual* (this chapter) introduces the manual.
- *Hardware description* gives a short description of the module.
- *Option description and instructions* describes the Safe motor temperature function implemented with the module and the drive Safe torque off function.
- *Mechanical installation* contains a delivery checklist and instructions on installing the module.
- *Electrical installation* contains instructions on wiring the module.
- *Parameter settings* lists the parameters related to the safety function.
- *Start-up and acceptance test* contains instructions on starting up the module and the acceptance test for the Safe motor temperature function.
- *Fault tracing* shows how to trace faults with the status LEDs on the module.
- *Technical data* contains the technical data of the module, the safety data and relevant certificates and Declarations of Conformity.

Related documents

- Product manuals, see the inside of the front cover.
 - ACS880 cabinet-built drives: Circuit diagrams delivered with the drive.
-

Terms and abbreviations

Term/abbreviation	Description
Cat.	Category. Classification of the safety-related parts of a control system in respect of their resistance to faults and their subsequent behavior in the fault condition, and which is achieved by the structural arrangement of the parts, fault detection and/or by their reliability. The categories are: B, 1, 2, 3 and 4.
CCF	Common cause failure (EN ISO 13849-1)
DC	Diagnostic coverage (%) (EN ISO 13849-1)
DI	Digital input
DO	Digital output
DTC	Direct torque control
EMC	Electromagnetic compatibility
Ex	An IEC term used in the context of explosive atmospheres
Ex d	Type of protection, flameproof enclosures (EN/IEC 60079-1)
Ex e	Type of protection, increased safety (EN 60079-7:2007 and IEC 60079-7:2006), to be replaced with Ex eb
Ex eb, Ex ec	Types of protection, increased safety (IEC 60079-7:2015)
Ex motors	Motors used in explosive atmospheres
Ex nA	Type of protection, non-sparking enclosures (EN/IEC 60079-15:2010), to be replaced with Ex ec
FEA-03	F-series extension adapter module
FPTC-01	Thermistor protection module
FSE-31	Pulse encoder interface module which can be used in safety applications
FSO	Safety functions module (FSO-12 or FSO-21)
FSO-12	Safety functions module which does not support the use of safety encoders

Term/abbreviation	Description
FSO-21	Safety functions module which supports the FSE-31 module and the use of safety encoders
GND	Ground
HFT	Hardware fault tolerance. (EN/IEC 62061, IEC 61508)
MTTF _D	Mean time to dangerous failure: (The total number of life units) / (the number of dangerous, undetected failures) during a particular measurement interval under stated conditions (EN ISO 13849-1)
PELV	Protected extra-low voltage (IEC 60364-4-41)
PF _D _{avg}	Average probability of dangerous failure on demand (IEC 61508, EN/IEC 61800-5-2, EN/IEC 62061)
PFH	Average frequency of dangerous failures per hour [1/h] (IEC 61508, EN/IEC 61800-5-2, EN/IEC 62061)
PL	Performance level (levels are: a, b, c, d and e). Corresponds to SIL. (EN ISO 13849-1)
PTC	Positive temperature coefficient
SAR	Safe acceleration range. In the FSO module, there are two sets of SAR parameters (SAR0 and SAR1) that are used to define and/or monitor the deceleration ramp in safety functions.
Safety system	Whole safety system including, for example, human interface, FPTC-01 module, FSO module, drive and sensors.
SBC	Safe brake control. A safety function in the FSO module.
SC	Systematic capability (IEC 61508)
SFF	Safe failure fraction (%) (IEC 61508).
SIL	Safety integrity level (levels are: 1, 2, 3, and 4). Corresponds to PL. (IEC 61508)
SILCL	SIL claim limit. Maximum SIL that can be claimed for a safety function or subsystem. (EN/IEC 62061)
SMT	Safe motor temperature. (EN/IEC 61800-5-2)

Term/abbreviation	Description
SS1	Safe stop 1 (EN/IEC 61800-5-2). A safety function in the FSO module.
SSE	Safe stop emergency. A safety function in the FSO module.
STO	Safe torque off. (EN/IEC 61800-5-2) In this manual, this term is used in two different contexts: <ul style="list-style-type: none"> • the STO circuit in the drive (the drive STO function) • the STO safety function in the FSO module.
Stop category 0	Uncontrolled stop (EN/IEC 60204-1)
Stop category 1	Controlled stop (EN/IEC 60204-1)
T1	Proof test interval (IEC 61508). T1 is a parameter used to define the probabilistic failure rate (PFH or PFD_{avg}) for the safety function or subsystem. Performing a proof test at a maximum interval of T1 is required to keep the SIL capability valid. The same interval must be followed to keep the PL capability (EN ISO 13849) valid. Note that any T1 values stated cannot be regarded as a guarantee or warranty. See also section Proof test interval on page 74.
XFLT	PTC input for the Safe motor temperature (SMT) fault in the FPTC module
XWRN	PTC input for a motor temperature warning in the FPTC module
Zone	Potentially explosive atmosphere. Hazardous areas are divided into zones, according to the degree of hazard. The degree of hazard is defined according to the probability of the occurrence of explosive atmospheres.

Exclusion of liability

ABB is not responsible for the implementation, verification and validation of the overall safety system. It is the responsibility of the end user (or other party) who is responsible for the overall system, system safety and compliance with Ex regulations.

The end user (or other responsible party) must make sure that the entire implementation complies with all relevant standards, directives and local electrical code, and that the system is tested, verified and validated correctly.



Hardware description

Contents of this chapter

This chapter gives a short description of the module.

Product overview

The FPTC-01 module implements the Safe motor temperature (SMT) safety function as defined in EN/IEC 61800-5-2:2007.

Inside the module, there is reinforced insulation between the motor thermistor connection and the other terminals of the module. The insulation forms a reliable protective separation between the motor main circuit and the drive control circuits. Therefore, the drive control board is PELV compatible also when the FPTC-01 module and a thermistor protection circuit are installed.

For more information on isolation areas of the module and insulation between them, see section [Isolation areas](#) on page 79.

■ Operation basics

The module includes two PTC sensor inputs:

- **XFLT** executes the SIL/PL capable SMT safety function by activating the drive Safe torque off (STO) function. This input is a safety-related input and can be used for protection function purposes.
- **XWRN** generates a warning to the drive. This is not a safety-related input and can only be used for indication purposes.

XFLT input (Fault)

When the motor temperature rises above the PTC sensor limit temperature, the sensor resistance increases sharply. This indicates overtemperature to the FPTC-01 module. The FPTC-01 module executes the SMT function by switching off the drive Safe torque off (STO) circuit. This activates the drive STO function.

The STO function disables the control voltage of the power semiconductors of the drive output stage. This prevents the drive from generating the torque required to rotate the motor. If the motor is running when the STO function is activated, it coasts to a stop.

Note: If you want to disable the SMT function, you have to connect a resistor (100 ohm...1 kohm 1/4 W wire-wound) in the XFLT input instead of a PTC sensor.

XWRN input (Warning)

When the motor temperature rises above the PTC sensor limit temperature, the sensor resistance increases sharply. The module sends a warning indication to the drive.

For the resistance limits and other technical details of the FPTC-01 module, see chapter [Technical data](#).

Layout

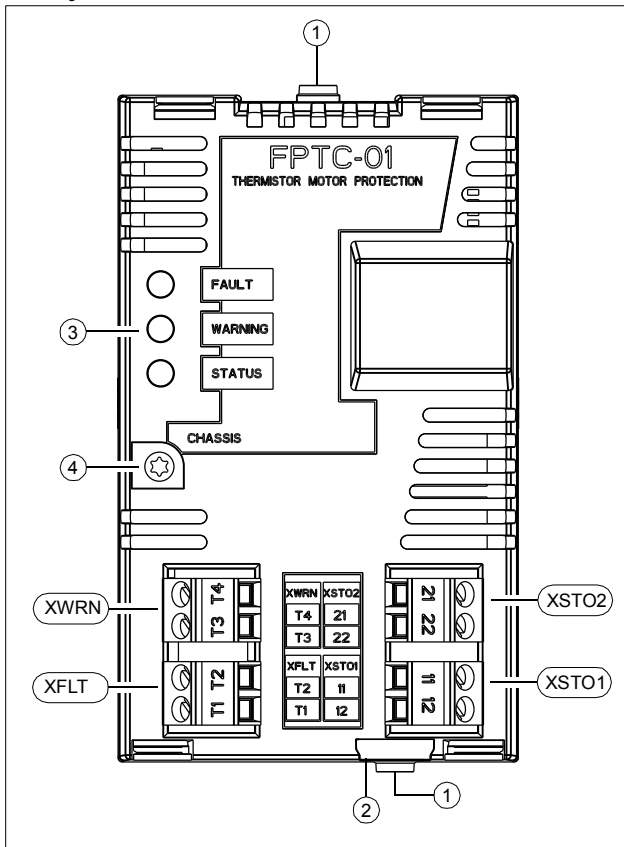

Item	Description
1	Retaining clips
2	Lock
3	Diagnostics LEDs (see section LEDs on page 72)
4	Mounting screw
XWRN	2-pin detachable terminal block for PTC warning (non-safety related)
XFLT	2-pin detachable terminal block for PTC fault (safety related)
XSTO1	2-pin detachable terminal block for STO output 1
XSTO2	2-pin detachable terminal block for STO output 2

Markings

The type designation label is attached on the back side of the FPTC-01 module. An example label and description of the label contents are shown below.



Item	Description
1	Type
2	Serial number of format RYWWSSSS, where R: Component revision: A, B, C, ... Y: Last digit of the manufacturing year: 4, 5, ... for 2014, 2015 WW: Manufacturing week: 01, 02, ... for week 1, week 2, ... SSSS: Integer starting every week from 0001
3	ABB MRP code of the module
4	Combined ABB MRP code, serial number and manufacturing location
5	RoHS mark



Option description and instructions

Contents of this chapter

This chapter describes the Safe motor temperature function implemented with the FPTC-01 module and the drive Safe torque off function and gives instructions for the user.

Overview

To implement the Safe motor temperature (SMT) function, you can connect the FPTC-01 module directly to the drive Safe torque off (STO) circuit, or you can use it together with an FSO module.

The FSO safety functions module (FSO-12 or FSO-21) is an optional device used with the ACS880 drives to implement safety functions. When installed, it reserves the standard STO connection of the drive. In this case, safety function in the FSO module can activate the STO function of the drive (that is, open the drive STO circuit).

Note: The Safe motor temperature function is motor-specific also in the ACS880 multidrives where several motors are connected to the drive.

■ **ACS880-01/04/04XT/04F/M04/11/31/14/34/104 drives and modules**

The module is available as a factory-installed option (+L536) or as an add-on kit for drives and modules.

For the kit, the user:

- installs the option module to an option slot of the drive control unit, and sets the related drive parameters
- connects the PTC temperature sensors of the motor to the PTC inputs of the option module, and
- connects the drive STO terminals to the STO output of the option module (or to the FSO module and configures the FSO module to perform the STO function).

■ **Cabinet-built drives**

For cabinet-built ACS880-07/17/37 single drives and ACS880 multidrives, the module is available as factory-installed options:

- +L536
- +L536+Q973 (with the FSO-12 module)
- +L536+Q972 (with the FSO-21 module)
- +L536+Q972+L521 (with the FSO-21 and FSE-31 modules).

The user connects the PTC temperature sensors of the motor to the PTC inputs of the module.

Resetting the safety function

The Ex regulations require that the safety function must be reset manually. When the XFLT input detects a motor overtemperature situation, the FPTC-01 module generates a fault to the drive. The user must reset the drive before it is possible to restart the drive.

When the XWRN input detects a motor overtemperature situation, the FPTC-01 module generates a warning to the drive. This is not a safety-related function and does not need a reset.

When an FSO module is used together with the FPTC-01 module, it is possible that the user must reset the safety function also with a reset button connected to the FSO module. This depends on parameter settings and other safety functions in the FSO module. For more information, see section [FSO module](#) on page 55.

Note: The reset function of the safety function is not SIL classified.

Indications of the safety function

An indication of the safety function can come from several sources:

1. LED indications on the FPTC-01 module:
 - The Fault LED is red when motor temperature is outside the allowed (safe) temperature range (XFLT input).
 - The WARNING LED is red when motor temperature outside the temperature warning range (XWRN input).
2. Safe motor temperature fault (XFLT) or motor temperature warning (XWRN) in the drive.
3. STO indication in the drive:
 - The drive STO indication is active when the SMT safety function has activated the drive STO function. The type of the indication is set with parameter [31.22](#).
4. STO indication on the FSO module:
 - The STO LED is green when the safety function has activated the drive STO.
5. STO indication from the FSO module to the drive:
 - The FSO module sends an indication to the drive when the FSO module activates the drive STO. The type of the indication is set with parameter [FSOGEN.61](#).

To avoid parallel indications, set the STO indication parameters ([31.22](#) and/or [FSOGEN.61](#)) to value *None/No indication* or *Event*. See chapter [Parameter settings](#) for instructions.

Note: The indications of the safety function are not SIL classified.

Switching frequency limitation

The certificate of the Ex motor requires that you set a minimum limit for the switching frequency of the drive. Make sure that the Ex motor is operated above the minimum switching frequency specified by the motor manufacturer.

For ABB Ex motors, use parameter [95.15](#) to set the required minimum switching frequency (see page [53](#)).

For Ex motors supplied by other motor manufactures, contact the motor manufacturer for the correct value and your local ABB representative for instructions on how to make the parameter setting in the drive.

Fault reaction function

FPTC-01 module

The FPTC-01 module has a fault reaction function. When the module detects an internal fault or fault in the temperature sensor circuit, it gives a request to the drive control unit to stop modulation and activates the drive STO function.

STO function in the drive/inverter modules

The STO function in the drive/inverter module has internal fault diagnostics and a fault reaction function which causes a fault trip in case it detects a redundancy fault of STO control signals or any internal failure. See the hardware and firmware manuals of the drive/inverter module.

FSO module

The fault reaction function of the FSO module trips the drive if it detects a failure. The FSO module activates the STO or Safe stop emergency (SSE) function. This activates the drive STO function. The drive STO function is active until the fault has been repaired.

Note: With the FPTC module, the recommended type of the SSE function is *Immediate STO*, but other safety functions in the FSO module can require that the type is *Emergency ramp*. With both settings, the FSO module always activates the drive STO function immediately in motor overtemperature situations (SMT function activated).

The FSO module goes into the Fail-safe mode. The FSO module LED STATUS/FAULT is red until the fault has been repaired.

To exit the Fail-safe mode, remove the cause of the fault and reset the FSO module by switching the power off and on, by pressing the **Boot FSO** button on the *Safety view* of Drive composer pro or with drive parameter *96.09 FSO reboot*. For more information, see the drive firmware manual and the FSO module user's manual.

5

Mechanical installation

Contents of this chapter

This chapter contains a delivery checklist and instructions on installing the module.

Necessary tools and instructions

- Torx screwdriver (T10)

For a complete list of tools, see the applicable drive hardware manual.



Unpacking and examining the delivery

1. Open the option package.
 2. Make sure that the package contains:
 - FPTC-01 module
 - STO cable
 - this manual.
 3. Make sure that there are no signs of damage.
-

Installing the module



WARNING! Obey the safety instructions. See chapter [Safety](#). If you ignore the safety instructions, injury or death can occur.

1. Pull out the lock.
2. Put the module carefully into its position on the drive until the retaining clips lock it into position.
3. Push in the lock.
4. Tighten the screw.

Note: The screw tightens the connections and grounds the module. It is necessary for fulfilling the EMC requirements and for proper operation of the module.



WARNING! Do not tighten the screw tighter than 0.8 N·m. Too high a torque breaks the thread.

See the applicable drive manual for further instructions on how to install the module to the drive.

Note: Do not install the FPTC-01 module on an FEA-03 F-series extension adapter. The diagnostics of the module requires that you install it directly on the drive control unit.

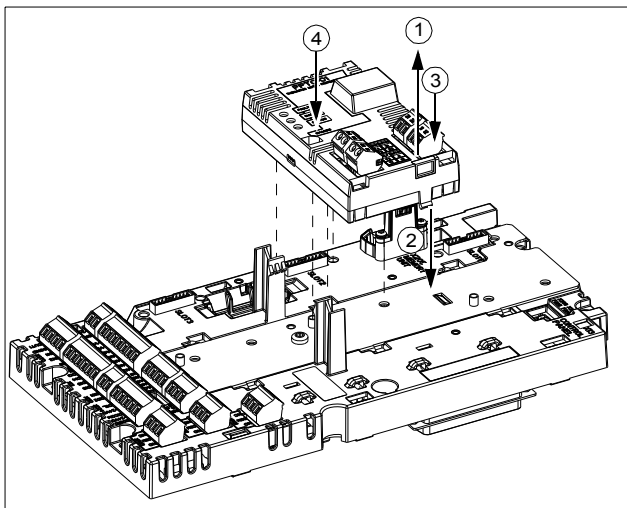



6

Electrical installation

Contents of this chapter

This chapter contains instructions on wiring the module.

Warnings



WARNING! Obey the safety instructions. See chapter [Safety](#). If you ignore the safety instructions injury or death can occur.

Make sure that the drive is disconnected from the input power during installation. If the drive is already connected to the input power, wait for 5 minutes after disconnecting the input power.

Necessary tools and instructions

Screwdriver with a set of suitable bits, cabling tools.



General cabling instructions

1. For the STO circuit wiring, use the type of cable specified in the appropriate drive or inverter module hardware manual (except when an FSO module or other safety relays are installed in the STO command chain).
2. Wire only the sensor circuit into the potentially explosive atmosphere.
3. The PTC sensor circuit in the Ex Zone must comply with the requirements for the applicable type of protection, such as:
 - Ex d (EN/IEC 60079-1),
 - Ex eb (IEC 60079-7:2015; Ex e in EN 60079-7:2007 and IEC 60079-7:2006),
 - Ex ec (IEC 60079-7:2015; Ex nA in EN/IEC 60079-15:2010).
4. Install the drive (or inverter module), the Safe torque off (STO) circuit, and the protection relay outside the hazardous zone.
5. Route the sensor cables away from the motor cable.
6. We recommend to use a shielded sensor cable to minimize electromagnetic interference from power cables.

Note: The drive STO function has a redundant architecture, that is, both STO channels must be used in the safety function implementation. For more information, see the hardware manual.

If you do not want to use the XFLT input (Fault), connect a resistor (100 ohm...1 kohm 1/4 W wire-wound) in the XFLT input instead of a PTC sensor.

If you do not want to use the XWRN input (Warning), disable the motor temperature warning with a parameter setting (see chapter [Parameter settings](#) on page 51).

Terminal designations

Marking	Description
XSTO1	STO channel 1
11	In, +24 V DC in for STO
12	Out, +24 V DC out for STO
XSTO2	STO channel 2
21	In, +24 V DC in for STO
22	Out, +24 V DC out for STO
XFLT	PTC FAULT (SMT function)
T1	In, 0...+5 V DC
T2	Out
XWRN	PTC WARNING (non-safety related)
T3	In, 0...+5 V DC
T4	Out



Wiring

This section presents five ways to connect the FPTC-01 module to the drive STO terminals.

Wiring example 1 (see page 45): The STO outputs of the FPTC-01 module are connected directly to the STO terminals of the drive.

- ACS880-01/04/04XT/04F/M04/11/31/14/34/104 drives and modules: In the factory-installed option (+L536), the wiring is done at the factory according to this example.
- ACS880 cabinet-built drives: In the option +L536, terminal block [X969] is located between the module and the drive control board (not shown in the figure). See the circuit diagrams delivered with the drive for the actual wiring.

Wiring example 2 (see page 46): The STO outputs of the FPTC-01 module are connected to an FSO module, and the STO outputs of the FSO module to the STO terminals of the drive with a two-channel connection. In this case, the FSO module controls the drive STO function.

- Cabinet-built drives: In the option +L536+Q973/Q972 (+L521), terminal block [X68] is located between the module and the FSO module (not shown in the figure). See the circuit diagrams delivered with the drive for the actual wiring.

Wiring example 3 (see page 47): An external safety relay is connected between the FPTC-01 module and the drive STO inputs with a two-channel connection.

Wiring example 4 (see page 48): The STO outputs of the FPTC-01 module are connected directly to the STO terminals of the drive with a one-channel connection.

Wiring example 5 (see page 49): The STO outputs of the FPTC-01 module are connected to an FSO module, and the STO outputs of the FSO module to the STO terminals of the drive with a one-channel connection.



Note: If you use a one-channel connection, make sure that you can reach the required safety integrity level (SIL).

Note: Only the XFLT input of the FPTC module is shown in the examples. The XWRN input is not safety-related and does not activate the drive STO function.

■ Wiring example 1

This connection is SIL2 capable (redundancy between STO channels).

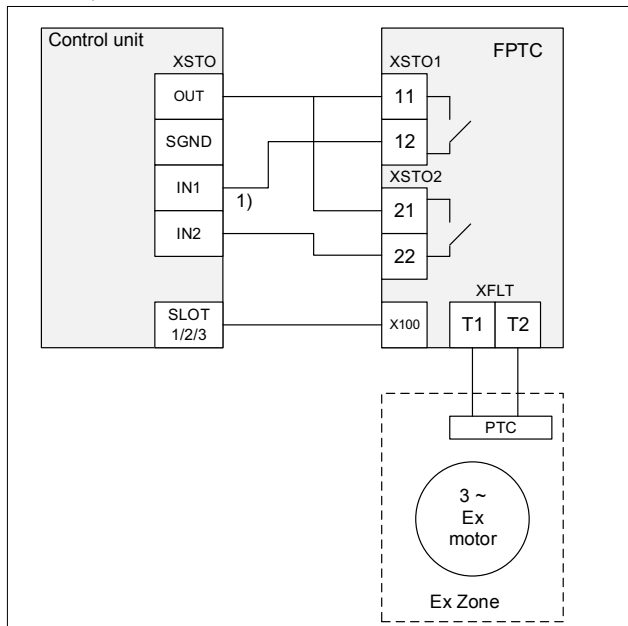

¹⁾ If necessary, you can connect an external device (eg, an emergency stop button) between the XSTO input of the control unit and the XSTO1 & XSTO2 outputs of the FPTC module. See [Wiring example 3](#) on page 47.

■ Wiring example 2

With an FSO module, two-channel connection. This connection is SIL2 capable (redundancy between STO channels).

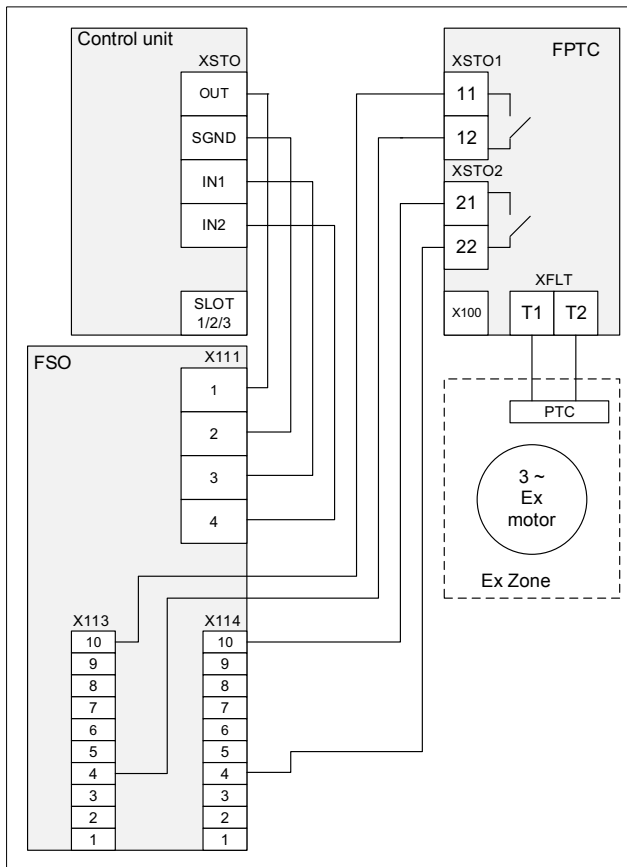

■ Wiring example 3

With an external safety relay, two-channel connection. This connection is SIL2 capable (redundancy between STO channels).

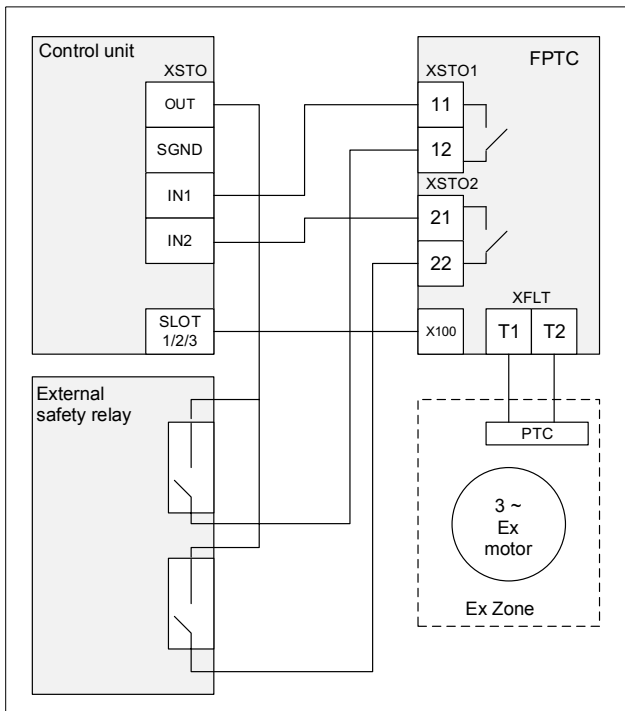

■ Wiring example 4

One-channel connection. This connection is SIL1 capable (no redundancy between STO channels).

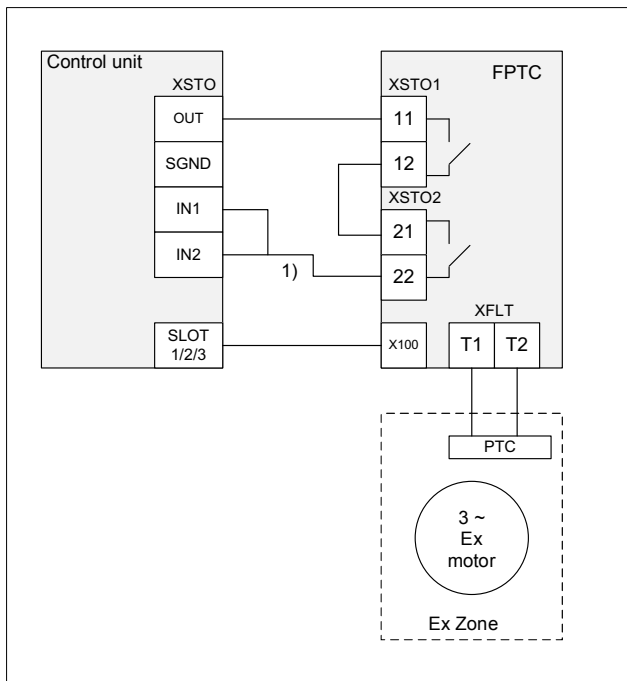

¹⁾ If necessary, you can connect an external device (eg, an emergency stop button) between the XSTO input of the control unit and the XSTO2 output of the FPTC module.

■ Wiring example 5

With an FSO module, one-channel connection. This connection is SIL1 capable (no redundancy between STO channels).

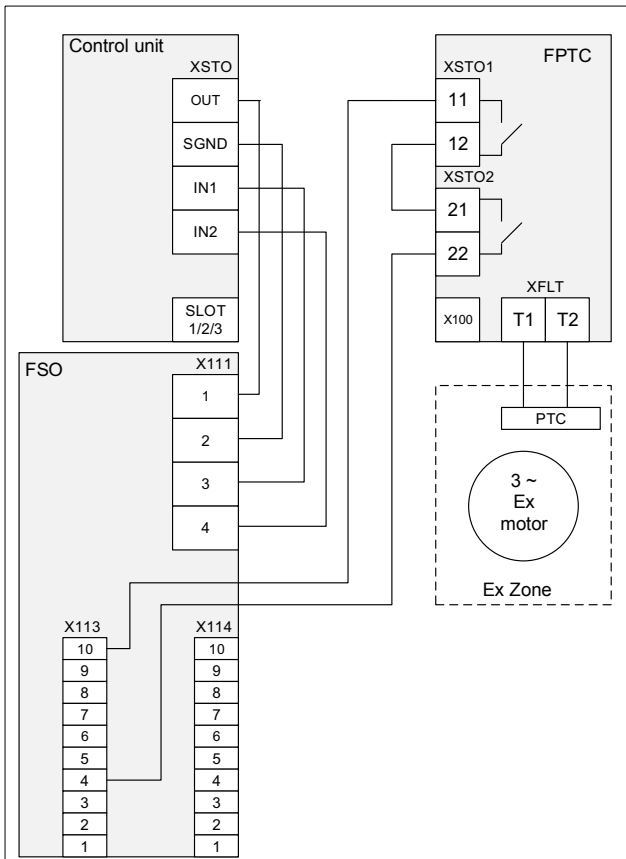



7

Parameter settings

Contents of this chapter

This chapter contains the drive and FSO module parameter settings.

Drive/inverter

Use the Drive composer PC tool or the control panel to set the parameter values.

This table lists the parameters related to the safety function in ACS880 primary control program. For more information, see the drive firmware manual.

Index	Name / Value	Description
31.22	STO indication run/stop	Selects which indications are given when one or both Safe torque off (STO) signals are switched off or lost. The indications also depend on whether the drive is running or stopped when this occurs. For more information, see the firmware manual.

Index	Name / Value	Description
	Warning/Warning	The drive generates a warning both when the drive is running and when it is stopped. This parameter value does not affect the SMT function, but this is the recommended setting (see section <i>Indications of the safety function</i> on page 33). For the cabinet-built drives, ABB has set this value at the factory.

35.30	FPTC configuration word	Activates FPTC modules installed on the control unit of the drive. With this word, it is also possible to suppress the non-safety related motor temperature warnings (XWRN input). It is not possible to suppress the SMT faults (XFLT input).
-------	-------------------------	---

Bit	Name	Description
0	Module in slot 1	1 = Yes: Module installed in slot 1.
1	Disable slot 1 warning	0 = No (default): Warnings from the module in slot 1 not suppressed. 1 = Yes: Warnings from the module in slot 1 suppressed.
2	Module in slot 2	1 = Yes: Module installed in slot 2.
3	Disable slot 2 warning	0 = No (default): Warnings from the module in slot 2 not suppressed. 1 = Yes: Warnings from the module in slot 2 suppressed.
4	Module in slot 3	1 = Yes: Module installed in slot 3.
5	Disable slot 3 warning	0 = No (default): Warnings from the module in slot 3 not suppressed. 1 = Yes: Warnings from the module in slot 3 suppressed.
6...15	Reserved	

Index	Name / Value	Description																																	
35.04	FPTC status word	Displays the status of FPTC modules. The word can be used as the source of eg. external events. This parameter is read-only.																																	
		<table border="1"> <thead> <tr> <th>Bit</th> <th>Name</th> <th>Description</th> </tr> </thead> <tbody> <tr> <td>0</td> <td>Module found in slot 1</td> <td>1 = Yes: An FPTC module has been detected in slot 1.</td> </tr> <tr> <td>1</td> <td>Fault active in slot 1</td> <td>1 = Yes: The module in slot 1 has an active SMT fault.</td> </tr> <tr> <td>2</td> <td>Warning active in slot 1</td> <td>1 = Yes: The module in slot 1 has an active motor temperature warning.</td> </tr> <tr> <td>3</td> <td>Module found in slot 2</td> <td>1 = Yes: An FPTC module has been detected in slot 2.</td> </tr> <tr> <td>4</td> <td>Fault active in slot 2</td> <td>1 = Yes: The module in slot 2 has an active SMT fault.</td> </tr> <tr> <td>5</td> <td>Warning active in slot 2</td> <td>1 = Yes: The module in slot 2 has an active motor temperature warning.</td> </tr> <tr> <td>6</td> <td>Module found in slot 3</td> <td>1 = Yes: An FPTC module has been detected in slot 3.</td> </tr> <tr> <td>7</td> <td>Fault active in slot 3</td> <td>1 = Yes: The module in slot 3 has an active SMT fault.</td> </tr> <tr> <td>8</td> <td>Warning active in slot 3</td> <td>1 = Yes: The module in slot 3 has an active motor temperature warning.</td> </tr> <tr> <td>9...15</td> <td>Reserved</td> <td></td> </tr> </tbody> </table>	Bit	Name	Description	0	Module found in slot 1	1 = Yes: An FPTC module has been detected in slot 1.	1	Fault active in slot 1	1 = Yes: The module in slot 1 has an active SMT fault.	2	Warning active in slot 1	1 = Yes: The module in slot 1 has an active motor temperature warning.	3	Module found in slot 2	1 = Yes: An FPTC module has been detected in slot 2.	4	Fault active in slot 2	1 = Yes: The module in slot 2 has an active SMT fault.	5	Warning active in slot 2	1 = Yes: The module in slot 2 has an active motor temperature warning.	6	Module found in slot 3	1 = Yes: An FPTC module has been detected in slot 3.	7	Fault active in slot 3	1 = Yes: The module in slot 3 has an active SMT fault.	8	Warning active in slot 3	1 = Yes: The module in slot 3 has an active motor temperature warning.	9...15	Reserved	
Bit	Name	Description																																	
0	Module found in slot 1	1 = Yes: An FPTC module has been detected in slot 1.																																	
1	Fault active in slot 1	1 = Yes: The module in slot 1 has an active SMT fault.																																	
2	Warning active in slot 1	1 = Yes: The module in slot 1 has an active motor temperature warning.																																	
3	Module found in slot 2	1 = Yes: An FPTC module has been detected in slot 2.																																	
4	Fault active in slot 2	1 = Yes: The module in slot 2 has an active SMT fault.																																	
5	Warning active in slot 2	1 = Yes: The module in slot 2 has an active motor temperature warning.																																	
6	Module found in slot 3	1 = Yes: An FPTC module has been detected in slot 3.																																	
7	Fault active in slot 3	1 = Yes: The module in slot 3 has an active SMT fault.																																	
8	Warning active in slot 3	1 = Yes: The module in slot 3 has an active motor temperature warning.																																	
9...15	Reserved																																		
95.15	Special HW settings	Contains hardware-related settings that can be enabled and disabled by toggling the specific bits.																																	
		<table border="1"> <thead> <tr> <th>Bit</th> <th>Name</th> <th>Description</th> </tr> </thead> <tbody> <tr> <td>0</td> <td>EX motor</td> <td>1 = The driven motor is an Ex motor provided by ABB for potentially explosive atmospheres. This sets the required minimum switching frequency for ABB Ex motors. Note: For non-ABB Ex motors, contact your local ABB representative.</td> </tr> </tbody> </table>	Bit	Name	Description	0	EX motor	1 = The driven motor is an Ex motor provided by ABB for potentially explosive atmospheres. This sets the required minimum switching frequency for ABB Ex motors. Note: For non-ABB Ex motors, contact your local ABB representative.																											
Bit	Name	Description																																	
0	EX motor	1 = The driven motor is an Ex motor provided by ABB for potentially explosive atmospheres. This sets the required minimum switching frequency for ABB Ex motors. Note: For non-ABB Ex motors, contact your local ABB representative.																																	

■ **Other recommended settings**

We recommend that you also set these parameters to improve the safety of the application:

- minimum and maximum speeds (parameter group 30)
- maximum current, power and torque (group 30)
- acceleration and deceleration times
- stall protection (parameters 31.24 ... 31.28)
- motor load curve (parameters 35.50 ... 35.55)
- motor cable protection (parameters 35.60 35.62)

For more information, see the drive firmware manual.

FSO module

If you use an FSO module with the FPTC-01 module, set and check the FSO parameters listed in this section.

You need the Drive composer pro PC tool to set the FSO module parameters, and a password to be able to download the configuration to the FSO module from Drive composer pro. For the default password of the FSO module, see the FSO module user's manual. For more information on the Drive composer pro PC tool, see *Start-up and maintenance PC tool Drive composer user's manual* (3AUA0000094606 [English]).

Follow the configuration steps described in the FSO module user's manual, chapter *Configuration*.

There are parameters that you must set always to keep the certificate valid and parameters that are related only to certain safety functions. This chapter lists the parameters that are relevant to the option +L536+Q973 (with FSO-12) and +L536+Q972 (with FSO-21).

You can use the FSO-21 module (+Q972) also with a safety pulse encoder and the FSE-31 pulse encoder interface module (+L521). In this case, set the parameters listed in section [FSE module and safety pulse encoder parameters](#) on page 62.

The example values apply to ACS880 cabinet-built drives. One FPTC module is connected to the FSO module with a two-channel connection (digital inputs X113:4 and X114:4, see the example on page 46).

Configure the FSO module so that it opens the drive STO circuit immediately after the safety function request from the FPTC module (stop category 0). With the FPTC module, you cannot use a stop function with a deceleration ramp (stop category 1). The FSO module always generates a fault and activates the drive STO function immediately in overtemperature situations.

■ General parameters

Set these FSO parameters always when you use the FSO module with the FPTC-01 module.

Index	Name	Example value	Description
FSOGEN. 11	Stop completed output	None ¹⁾	Sets the digital output that indicates the completion of any stop function. Active when the FSO module has completed the STO, SSE or SS1 function.
FSOGEN. 21	Motor nominal speed	1500 rpm	Sets the nominal motor speed. Adjust the default value to meet the motor in use.
FSOGEN. 22	Motor nominal frequency	50 Hz	Sets the nominal motor frequency. Adjust the default value to meet the motor in use.
FSOGEN. 41	Power-up acknowledgement	Automatic	Sets the power-up acknowledgement method of the FSO module. <i>Automatic:</i> You do not need to push a reset button after switching on the FSO module. The FSO module generates the acknowledgement signal automatically after the power-up. <i>Manual:</i> The FSO module reads the external acknowledgement signal through the digital input defined by parameter FSOGEN.42 . Make sure that the value is <i>Automatic</i> .
FSOGEN. 42	Acknowledgement button input	None ¹⁾	Selects the digital input for the acknowledgement signal when parameter STO.02 has value <i>Manual</i> . In the safety function described in this manual, parameter STO.02 has value <i>Automatic</i> and this parameter has value <i>None</i> (no acknowledgement signal connected to the input).

Index	Name	Example value	Description
	FSOGEN. STO 61 indication ext request	Warning ¹⁾	<p>Sets the type of the event that the FSO module generates and sends to the drive after external requests that end to a successful activation of the drive STO function (STO, SSE or SS1).</p> <p><i>None, Warning, Event:</i> You do not have to reset the drive/inverter before you can restart it.</p> <p><i>Fault:</i> You have to reset the drive/inverter before you can restart it.</p>

¹⁾ The value does not affect the SMT function, but other safety functions in the FSO module can require a certain value (see sections [Resetting the safety function](#) on page 32, [Indications of the safety function](#) on page 33 and [Additional notes](#) on page 64).

Parameters related to the STO function

These parameters are related to the STO function of the FSO module. With stop category 0, the FSO module activates the STO function in overtemperature situations. In addition, the FSO module can activate the STO function in fault situations.

Index	Name	Example value	Description
STO.02	STO acknowledgement	Automatic ¹⁾	<p>Sets the acknowledgement method used in the STO, SSE and SS1 functions.</p> <p><i>Automatic:</i> The FSO module resets the STO function automatically after the STO request have been removed.</p> <p><i>Manual:</i> The FSO module reads the external acknowledgement signal through the digital input defined by parameter FSOGEN.42.</p>
STO.11	STO input A	None	<p>Sets the digital input that is connected to the primary input of the STO function.</p> <p>In this example, this parameter has value <i>None</i>.</p> <p>Note: The default value after factory reset is <i>DI X113:1 & X114:1</i>. Always check this parameter after factory reset.</p>
STO.12	STO input B	DI X113:4 & X114:4	<p>Sets the digital input that is connected to the secondary input of the STO function.</p> <p>Note: The default value after factory reset is <i>None</i>. Always check this parameter after factory reset.</p> <p>Note: In a non-redundant system, (Wiring example 5 on page 49), you can use a one-channel input (for example, <i>DI X113:4</i>).</p>

Index	Name	Example value	Description
STO.13	Restart delay after STO	2000 ms	<p>Sets the time after which the restart of the drive is allowed after the FSO module has activated the STO function and opened the drive STO circuit. With this parameter, you can allow a restart of the drive before the motor has stopped (fly-start). This parameter is valid only if the STO function is requested from STO input A (STO.11) or STO input B (STO.12).</p> <p>Adjust the value when necessary. If you do not want to use the fly-start feature, set this parameter to the same value as parameter STO.14.</p>
STO.14	Time to zero speed with STO or modoff ²⁾	2000 ms	<p>Sets the time after which the acknowledgement is allowed after coast stop in the STO and SSE functions. Configured to the estimated time in which the motor coasts to a stop from the maximum speed.</p> <p>This parameter sets the time after which the STO function is completed. Parameter STO.13 defines the time after which the restart of the drive is allowed. Adjust the value when necessary.</p> <p>Note: The default value after factory reset is 3,600,000 ms. Always check this parameter after factory reset.</p>
SBC usage			
SBC.11	STO SBC usage	None	<p>Sets how the mechanical brake is used together with the STO function. In the safety function described in this manual, this feature is not used. Make sure that the value is <i>None</i>. See also section Mechanical brake control on page 64.</p>

Index	Name	Example value	Description
I/O settings			
	SAFEIO. DI X113:4 36 diag pulse on/off	On ³⁾	Sets the diagnostic pulse of digital input X113:4 on or off. <i>On</i> : The input monitors that it receives test pulses. In this example (see page 49), the STO request is connected to this digital input.
	SAFEIO. DI X114:4 40 diag pulse on/off	On ³⁾	Sets the diagnostic pulse of digital input X114:4 on or off. <i>On</i> : The input monitors that it receives test pulses. In this example (see page 49), the STO request is connected to this digital input. Note: In a non-redundant system, (<i>Wiring example 5</i> on page 49), you can use a one-channel input (for example, <i>DI X113:4</i>). In this case, this parameter has no effect.

¹⁾ The value does not affect the SMT function, but other safety functions in the FSO module can require a certain value (see sections *Indications of the safety function* on page 33 and *Additional notes* on page 64).

²⁾ When a safety encoder is used: This parameter is relevant only if there is an encoder failure and the FSO module activates the STO function. For more information, see the FSO-21 module user's manual.

³⁾ The safety data (see page 81) is based on the assumption that this diagnostic measure for the wiring is active (*On*). If pulsing is disabled, you must consider other measures to ensure sufficient diagnostic coverage of the wiring failures.

■ Parameters related to the SSE function

These parameters are related to the Safe stop emergency (SSE) function of the FSO module. The safety function described in this manual does not use this function, but the FSO module can activate the SSE function in internal fault situations.

Index	Name	Example value	Description
SSE.13	SSE function	Immediate STO ¹⁾	<p>Sets the type of the SSE function.</p> <p><i>Immediate STO</i>: The FSO module activates the drive STO function immediately after the SSE request (stop category 0).</p> <p><i>Emergency ramp</i>: The FSO module first ramps down the motor speed and when the speed is below the zero speed limit, it activates the STO function (stop category 1). SAR0 parameters define the deceleration ramp. For more information, see the FSO module user's manual.</p> <p>Note: The default value after factory reset is <i>Emergency ramp</i>. Always check this parameter after factory reset.</p>
SBC usage			
SBC.15	SSE/SS1 SBC speed	0 rpm	<p>Sets the absolute speed below which the FSO module activates the brake (SBC) while ramping.</p> <p><i>0 rpm</i>: The feature is not in use.</p> <p>In the safety function described in this manual, this feature is not used. Make sure that the value is <i>0 rpm</i>.</p> <p>See also section Mechanical brake control on page 64.</p>

¹⁾ With the FPTC module, the recommended value is *Immediate STO*, but other safety functions in the FSO module can require that the value is *Emergency ramp*. With both settings, the FSO module always activates the drive STO function immediately in motor overtemperature situations (SMT function activated).

■ FSE module and safety pulse encoder parameters

Set these parameters only when you use a safety pulse encoder and the FSE-31 pulse encoder interface module with the FSO-21 module.

Index	Name	Example value	Description
200.231	FSE 3X act and par version	Version 1	Activates the FSE-31 encoder interface and shows the version of the encoder parameter groups (91 and 92).
200.232	Number of encoders	Single encoder CH1	Shows the number of safety pulse encoders connected to the FSE module.
S_ENC GEN.01	Safe pulse encoder version	Version 1	Activates the safety pulse encoder and shows the version parameter group <i>S_ENC GEN.</i>
S_ENC GEN.11	FSE diagnostic failure reaction	STO	Sets the action taken when there is a problem in the FSE module or the safety encoder. <i>STO</i> : The FSO module goes into the Fail-safe mode and activates the drive STO function. For more information, see the FSO-21 module user's manual.
S_ENC GEN.14	Enc speed cross comp tolerance	1 rpm	Sets the encoder speed cross comparison tolerance. This defines how much the axle speed of the motor can change within 1 ms. Adjust the default value to meet the motor in use.
S_ENC GEN.41	Gear numerator encoder 1	1	Sets the rotation direction for the safety pulse encoder. With this parameter, you can change the rotation direction of the motor. Adjust the default value if necessary.
91.11	Module 1 type	FSE-31	Sets the type of the safety pulse encoder interface module 1.
91.12	Module 1 location	2	Sets the slot in which the safety pulse encoder interface module 1 is located.

Index	Name	Example value	Description
92.01	Encoder 1 type	HTL1	Activates or deactivates the communication with the safety pulse encoder interface module 1 and sets the type for the safety pulse encoder.
92.02	Encoder 1 source	Module 1	Sets the safety pulse encoder interface module that the safety pulse encoder 1 is connected to.
92.10	Pulses/revolution	2048	Sets the number of HTL pulses per revolution for safety pulse encoder 1. Adjust the default value to meet the safety pulse encoder in use. Make sure that the value is according to the encoder nameplate.
92.17	Accepted pulse freq of encoder 1	300 kHz	<p>Sets the maximum pulse frequency range of encoder 1.</p> <p>Adjust the default value to meet the motor and safety pulse encoder in use. You can use this formula to define the value:</p> $r_max \times ppr_enc + 10\%$ <p>where</p> <ul style="list-style-type: none"> • r_max = the maximum motor speed (rpm) used in the application (or the motor nominal speed) • ppr_enc = Pulses/revolution of the safety pulse encoder (parameter 92.10). <p>Set the parameter value in kHz.</p> <p>For more information, see the FSO-21 module user's manual.</p>

■ **Additional notes**

ACS880-07/17/37 drives with the option +Q978

In motor overtemperature situations, the FSO module also opens the main contractor/circuit breaker.

ACS880-07/17/37 drives with the option +Q978 or +Q979

The FSO module is configured so that after the safety function activation, the user must reset the FSO manually with the emergency stop reset button. In this case, the user must reset the FSO module with the emergency stop reset button also in motor overtemperature situations. Also the indication lamp on the reset button is illuminated.

The compliance of the emergency stop function with the relevant standards requires this setting. Do not change this setting.

Mechanical brake control

If you use a mechanical brake with the thermal motor protection circuit, pay special attention to the control of the mechanical brake.

If the motor deceleration by the mechanical brake causes extra heat generation in the Ex zone, make sure that the use of the brake does not rise the temperature excessively.

In some cases you cannot use the brake for the motor deceleration when the motor thermal protection circuit has tripped, and the motor temperature is excessive already.

For more information, see the drive firmware manual (or the FSO user's manual if you use the Safe brake control (SBC) function of the FSO module).

8

Start-up and acceptance test

Contents of this chapter

This chapter contains the start-up instructions and the acceptance test for the safety function.

Note: Only a competent person with expertise and knowledge of the safety function as well as functional safety and Ex regulations can do the start-up and adjust the related settings (IEC 61508-1 clause 6).

Before you start

Make sure that you have completed these start-up tasks for the drive:

- Checks and settings with no voltage connected
- Powering up the drive
- Setting up the drive control program.

See the applicable drive hardware manual.



Make sure you have set the correct parameter values for the safety function. See chapter [Parameter settings](#).



Acceptance test

You need the Drive composer PC tool or the control panel to perform the acceptance test.

Initial status: Make sure that the drive is ready for use, that is, you have done the tasks of the drive start-up procedure. See the hardware manual.

Action	<input checked="" type="checkbox"/>
 WARNING! Obey the safety instructions. See chapter Safety . If you ignore the safety instructions injury or death can occur.	<input type="checkbox"/>
Checks and settings with no voltage connected	
The motor manufacturer selects the PTC sensors for the motor temperature measurement according to the specified temperature class. Make sure that the temperature on-off resistances match those of the FPTC module.	<input type="checkbox"/>
After you have done the wiring, check the connections against the appropriate circuit diagrams and examples in chapter Electrical installation .	<input type="checkbox"/>
Drives with R8i inverter modules: Check that the STO OUT output on the inverter control unit [A41] is chained to the STO inputs of all inverter modules. The STO circuit is disabled in spare part modules.	<input type="checkbox"/>
Make sure that the SIL/PL of the safety function meets the target SIL/PL. If SIL2 is required, make sure that the STO connection between the FPTC module and drive STO is kept separated.	<input type="checkbox"/>
 Settings with voltage connected	
Make sure that you have activated the FPTC module in the correct slot (parameter 35.30).	<input type="checkbox"/>
Make sure that all parameters relevant to the safety function are set as defined in chapter Parameter settings on page 51 .	<input type="checkbox"/>
Acceptance test procedure	
Make sure that you can run and stop the motor freely during the test.	<input type="checkbox"/>
Start drive and make sure that motor is running.	<input type="checkbox"/>
Cause an overtemperature situation: <ul style="list-style-type: none"> increase the resistance in the XFLT input above 3.6 kohm (for example, open-circuit). 	<input type="checkbox"/>

Action	<input checked="" type="checkbox"/>
Make sure that the correct indications are activated: • the SMT fault and other indications depending on the parameter settings and if an FSO module is installed (see section <i>Indications of the safety function</i> on page 33).	<input type="checkbox"/>
Make sure that the STO is activated and the motor stops by coasting (see parameter 31.22).	<input type="checkbox"/>
Make sure that you cannot start the drive before you have reset the drive.	<input type="checkbox"/>
Reset the drive. Make sure you cannot reset and restart the drive before the input resistance in the XFLT input has been decreased below 1.6 kohm.	<input type="checkbox"/>
Restart the drive and motor and make sure they operate normally.	<input type="checkbox"/>
Cause a short-circuit situation: • decrease the resistance in the XFLT input below 50 ohm.	<input type="checkbox"/>
Make sure that the correct indications are activated: • the SMT fault and other indications depending on the parameter settings and if an FSO module is installed (see section <i>Indications of the safety function</i> on page 33).	<input type="checkbox"/>
Make sure that the STO is activated and the motor stops by coasting (see parameter 31.22).	<input type="checkbox"/>
Make sure that you cannot start the drive before you have reset the drive.	<input type="checkbox"/>
Reset the drive. Make sure you cannot reset and restart the drive before the input resistance in the XFLT input has been increased above 50 ohm.	<input type="checkbox"/>
Restart the drive and motor and make sure you they operate normally.	<input type="checkbox"/>
If in use, test the XWRN input: Connect a resistor (resistance 100 ohm...1 kohm) between the XFLT inputs. Make sure the motor temperature warning indication is activated in motor overtemperature and short-circuit situations.	<input type="checkbox"/>
Fill in and sign the acceptance test report which verifies that the safety function is safe and accepted to operation.	<input type="checkbox"/>

Note: If you use only the XWRN input of the FPTC module, connect a resistor (100 ohm...1 kohm 1/4 W wire-wound) between the XFLT inputs and the test the XWRN indication.





9

Fault tracing

Contents of this chapter

This chapter shows how to trace faults with fault and warning messages and LEDs on the module.

Reporting failures

You must report any failures of the FPTC-01 and FSO modules and the drive Safe torque off function to ABB.

FPTC-01 module replacement

If the FPTC-01 module fails to operate, you have to replace it with a new one. You cannot repair the module.

Fault and warning messages

The fault and warning messages in the ACS880 primary control program are these:

Code (hex)	Name	Cause	What to do
Faults			
4991	Safe motor temperature 1 (Editable message text)	The FPTC module in option slot 1 indicates overtemperature in the XFLT input (safety related). 1. Motor temperature is too high, or 2. the thermistor is in short-circuit or disconnected.	<ol style="list-style-type: none"> 1. Check the cooling of the motor. 2. Check the motor load and drive ratings. 3. Check the wiring of the temperature sensor. Repair wiring if faulty. 4. Measure the resistance of the sensor. Replace the sensor if faulty.
4992	Safe motor temperature 2 (Editable message text)	The FPTC module in option slot 2 indicates overtemperature in the XFLT input (safety related). See 4991.	
4993	Safe motor temperature 3 (Editable message text)	The FPTC module in option slot 3 indicates overtemperature in the XFLT input (safety related). See 4991.	
4990	FPTC not found	A thermistor protection module has been activated by parameter 35.30 but cannot be detected. The last digit of the auxiliary code identifies the slot.	Power down the control unit and check that the module is properly inserted in the correct slot.

Code (hex)	Name	Cause	What to do
Warnings			
A497	Motor temperature 1 (Editable message text)	The FPTC module in option slot 1 has activated a motor temperature warning in the XWRN input (non-safety related). 1. Motor temperature is too high, or 2. the thermistor is in short-circuit or disconnected.	<ol style="list-style-type: none"> 1. Check the cooling of the motor. 2. Check the motor load and drive ratings. 3. Check the wiring of the temperature sensor. Repair wiring if faulty. 4. Measure the resistance of the sensor. Replace sensor if faulty.
A498	Motor temperature 2 (Editable message text)	The FPTC module in option slot 2 has activated a motor temperature warning in the XWRN input (non-safety related). See A497.	
A499	Motor temperature 3 (Editable message text)	The FPTC module in option slot 3 has activated a motor temperature warning in the XWRN input (non-safety related). See A497.	

For the fault and warning messages of the FSO module, see the FSO module user's manual.

LEDs

The FPTC-01 module has three diagnostic LEDs.

Name	Color	Description
FAULT	Red	The motor temperature is outside the allowed temperature range and the drive STO is active, or there is no PTC sensor connected to the XFLT input (safety related).
WARNING	Red	The motor temperature is outside the temperature warning range, or there is no PTC sensor connected to the XWRN input (non-safety related).
STATUS	Green	The module is powered up.

Note: When there is no sensor connected to the XWRN input, the WARNING LED is red even if you have suppressed the warnings from the module. You can connect a resistor (100 ohm...1 kohm 1/4 W wire-wound) in the XWRN input to turn off the WARNING LED.

10

Maintenance

Contents of this chapter

This chapter gives maintenance instructions.

Maintenance

After the operation of the safety circuit has been tested at start-up, it does not need any maintenance during its specified lifetime, but the safety circuit must be tested periodically to keep the SIL/PL capability valid.

In addition to proof testing, it is a good practice to check the operation of the safety function when other maintenance procedures are carried out on the machinery. Do the acceptance test described in chapter [Start-up and acceptance test](#).

If you change any wirings or components after the start-up, replace the FPTC-01 module, modify drive or FSO parameters or restore parameters to their factory default values, you must:

- Use only ABB approved spare parts.
- Register the change to the change log for the safety circuit or logbook of the machine.
- Test the safety function again after the change. Obey the rules given in chapter *Start-up and acceptance test*.
- Document the tests and store the report into the logbook of the machine.

Proof test interval

After the operation of the safety function is validated at start-up, the safety function must be maintained by periodic proof testing. In high demand mode of operation, the maximum proof test interval is 20 years. In low demand mode of operation, the maximum proof test interval is 2 years (high or low demand as defined in IEC 61508, EN/IEC 62061 and EN ISO 13849-1). Regardless of the mode of operation, it is a good practice to check the operation of the safety function at least once a year. Do the test as described in chapter *Start-up and acceptance test*.

The person responsible for the design of the complete safety function should also note the Recommendation of Use CNB/M/11.050 published by the European co-ordination of Notified Bodies concerning dual-channel safety-related systems with electromechanical outputs:

- When the safety integrity requirement for the safety function is SIL 3 or PL e (cat. 3 or 4), the proof test for the function must be performed at least every month.
 - When the safety integrity requirement for the safety function is SIL 2 (HFT = 1) or PL d (cat. 3), the proof test for the function must be performed at least every 12 months.
-

This is a recommendation and depends on the required (not achieved) SIL/PL. For example, contactors, breakers, safety relays, contactor relays, emergency stop buttons, switches etc. are typically safety devices which contain electromechanical outputs. The FPTC-01 and FSO modules and the STO circuit of the drive do not contain electromechanical outputs.

Competence

The maintenance and proof test activities of the safety function must be carried out by a competent person with expertise and knowledge of the safety function as well as functional safety, as required by IEC 61508-1 clause 6 and Ex regulations.

Residual risk

The safety functions are used to reduce the recognized hazardous conditions. In spite of this, it is not always possible to eliminate all potential hazards. Therefore the warnings for the residual risks must be given to the operator.

Intentional misuse

The safety circuit is not designed to protect a machine against intentional misuse.

Decommissioning

When you decommission the module, make sure that the safety of the machine is maintained until the decommissioning is complete.

Mark clearly on the module that it is decommissioned.

11

Technical data

Contents of this chapter

This chapter contains the technical data of the module, gives general rules, notes and definitions related to safety functions and lists the related standards and directives. The safety data, relevant certificates and Declarations of Conformity are also included.

Dimension drawing

The dimensions are in millimeters and [inches].

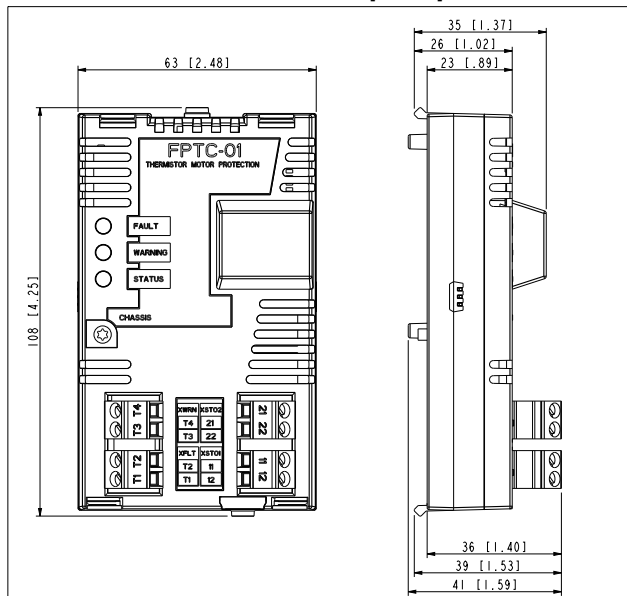

Isolation areas

This figure describes the different isolation areas of the module. Isolation areas A and B and the mounting screw are connected to ground. Isolation area C is in the same potential as the PTC sensor element in the motor.

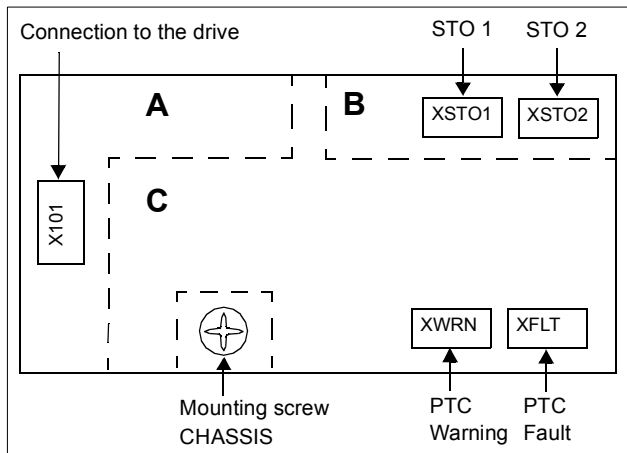

There is reinforced insulation between isolation areas A and C as well as between isolation areas B and C.

Connections

■ **Motor thermistor connection**

- Wire size max. 2.5 mm²
- Length max. 700 m (2300 ft)
(1400 m [4600 ft] for the whole loop)
- With the specified cable type: Detection of a short-circuited PTC sensor or cable is not guaranteed after 100 m (330 ft).
- Type: Draka JAMAK 1 x (2 + 1) x 0.5 mm² or similar
- Torque: 0.5 N·m
- Supported standards: DIN 44081 and DIN 44082
- Number of PTC thermistors: 1, 3 or 6 in series (in both inputs)
- Triggering threshold: 3.6 kohm (± 10%)
- Recovery threshold: 1.6 kohm (± 10%)
- PTC terminal voltage: < 5.0 V
- PTC terminal current: < 1 mA
- Short-circuit detection: < 50 ohm (± 10%)
(for the effect of the cable length, see above)

■ **STO output connection**

- Wire size max. 2.5 mm² (with an FSO module: 1.5 mm²)
- Length max. 30 m (100 ft) (for the whole loop)
- Torque: 0.5 N·m
- Contact rating: 24 V DC (17...30 V), 1 A / channel
- Maximum breaking capacity: 1000 VA

Ambient conditions

See the drive technical data.

Safety data

The FPTC-01 module is a type A safety component as defined in IEC 61508-2.

The table gives the safety data for the SMT function with different configurations. The calculations are based on the worst case data of the drive Safe torque off (STO) function. The PFH/PFD_{avg} values can be different based on the internal configuration of the FSO module.

Note: The failure rate of the PTC sensor is not included in the calculations.

Two-channel configurations

1. FPTC module + drive STO (see [Wiring example 1](#) on page 45)
2. FPTC module + drive STO + FSO module with STO function request (see [Wiring example 2](#) on page 46), or
3. FPTC module + drive STO + external safety relay (see [Wiring example 3](#) on page 47).

One-channel configurations

4. FPTC module + drive STO (see [Wiring example 4](#) on page 48)
 5. FPTC module + drive STO + FSO module with STO function request (see [Wiring example 5](#) on page 49).
-

	Two-channel configurations			One-channel configurations	
	1	2	3	4	5
SIL / SILCL	2	2	2	1	1
PL	c	c	c	c	c
SFF (%)	>90	>90	>90	>60	>60
PFH (1/h) (T1 = 20a)	5.51 E-09	5.58 E-09	5.51 E-09	7.71E-09	8.29 E-09
PFD_{avg} (T1 = 2 a)	4.82 E-05	4.91 E-05	4.82 E-05	6.21E-05	6.75 E-05
PFD_{avg} (T1 = 5 a)	1.21E-04	1.22E-04	1.21E-04	1.57E-04	1.70E-04
DC (%)	60	60	60	0	0
SC	2	2	2	2	2
Cat.	1	1	1	1	1
HFT	0	0	0	0	0
CCF	65	65	65	65	65
Lifetime (a)	20	20	20	20	20

3AXD10000454332, Rev C

The MTTF_D value (EN ISO 13849-1) of the module:

- 1708 years (two-channel connection)
- 1703 years (one-channel connection)

Safety block diagrams

The components that are included in the safety data calculations are shown in the safety block diagrams below.

Note: The failure rate of the PTC sensor is not included in the calculations.

Two-channel configurations

This diagram applies to configuration 1.

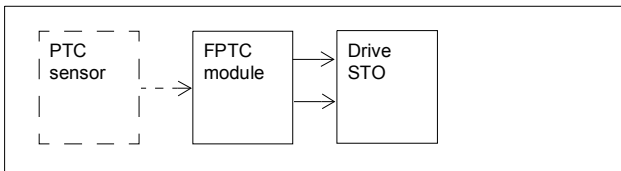

This diagram applies to configuration 2.

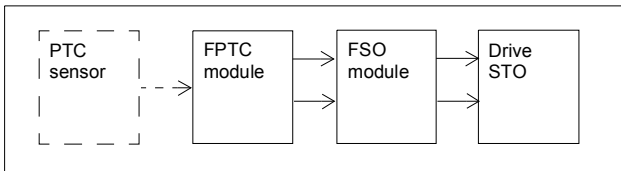

This diagram applies to configuration 3.

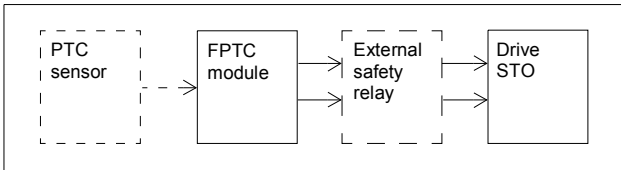

Note: The failure rate of the external safety relay is not included in the calculation.

One-channel configurations

This diagram applies to configuration 4.

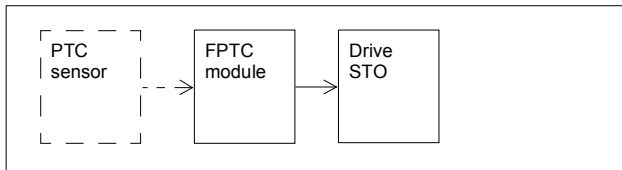

This diagram applies to configuration 5.

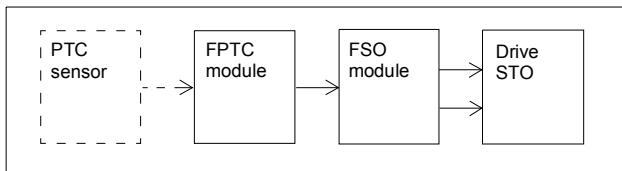

Note: The failure rate of the safety encoder is not included in the calculation.

Response times

- FPTC-01module: less than 10 ms
- SMT function: the response time of the PTC sensor + FPTC-01 module (<10 ms) + FSO module (<50 ms) + drive STO (<50 ms)

Relevant failure modes

- The SMT function trips spuriously (safe failure)
- The SMT function does not activate when requested

A fault exclusion on the failure mode "short-circuit on printed circuit board" has been made (EN 13849-2, table D.5). The analysis is based on the assumption that one failure occurs at one time. No accumulated failures have been analyzed.

The failures of the PTC sensor (thermistor) are not included in the failure analysis. The customer is responsible for the applicability of the PTC element.

General rules, notes and definitions

■ Validation of the safety functions

You must do an acceptance test (validation) to validate the correct operation of safety functions.

■ Validation procedure

You must do the acceptance test using the checklist given in chapter *Start-up and acceptance test*:

- at initial start-up of the safety function
- after any changes related to the safety function (circuit boards, wiring, components, settings, restoring parameter values to factory settings, etc.)
- after any maintenance work related to the safety function.

The acceptance test must include at least the following steps:

- having an acceptance test plan
 - testing all commissioned functions for proper operation, from each operation location
 - documenting all acceptance tests
 - signing and storing the acceptance test report for further reference.
-

■ Acceptance test reports

You must store the signed acceptance test reports in the logbook of the machine. The report must include, as required by the referred standards:

- a description of the safety application (including a figure)
- a description and revisions of safety components that are used in the safety application
- a list of all safety functions that are used in the safety application
- a list of all safety related parameters and their values
- documentation of start-up activities, references to failure reports and resolution of failures
- the test results for each safety function, checksums, date of the tests and confirmation by the test personnel.

You must store any new acceptance test reports performed due to changes or maintenance in the logbook of the machine.

■ Competence

The acceptance test of the safety function must be carried out by a competent person with expertise and knowledge of the safety function as well as functional safety, as required by IEC 61508-1 clause 6 and Ex regulations. The test procedures and report must be documented and signed by this person.

■ Ambient conditions

For the environmental limits for the safety function and the drive, refer to the hardware manual of your drive.

■ Reporting problems and failures related to safety functions

Contact your local ABB representative.

Related standards and directives

Standard	Name
IEC 61508:2010	<i>Functional safety of electrical/electronic/programmable electronic safety-related systems. Part 1 – General requirements Part 2 – Requirements for electrical/electronic/programmable electronic safety-related systems</i>
EN 61800-5-2:2007 IEC 61800-5-2:2016	<i>Adjustable speed electrical power drive systems – Part 5-2: Safety requirements – Functional</i>
EN 62061:2005 +AC:2010+A1:2013 +A2:2015 IEC 62061:2015 Ed.1.2	<i>Safety of machinery – Functional safety of safety-related electrical, electronic and programmable electronic control systems</i>
EN ISO 13849-1:2015	<i>Safety of machinery – Safety-related parts of control systems – Part 1: General principles for design</i>
EN ISO 13849-2:2012	<i>Safety of machinery – Safety-related parts of control systems – Part 2: Validation</i>
EN 60204-1:2006 +AC:2010 IEC 60204-1:2016	<i>Safety of machinery – Electrical equipment of machines – Part 1: General requirements</i>
IEC 61326-3-1:2008	<i>Electrical equipment for measurement, control and laboratory use – EMC requirements – Part 3-1: Immunity requirements for safety-related systems and for equipment intended to perform safety-related functions (functional safety) – General industrial applications</i>
IEC 61511-1:2016	<i>Functional safety - Safety instrumented systems for the process industry sector – Part 1: Framework, definitions, system, hardware and application programming requirements</i>
2006/42/EC	<i>European Machinery Directive</i>

Compliance with the European Machinery Directive

The drive is an electronic product which is covered by the European Low Voltage Directive. However, the drive internal safety function of this manual (option +L536) is in the scope of the Machinery Directive as a safety component. This function complies with European harmonized standards such as EN/IEC 61800-5-2. The declarations of conformity are shown below.



EU Declaration of Conformity

Machinery Directive 2006/42/EC

We

Manufacturer: ABB Oy
Address: Hiomotie 13, 00380 Helsinki, Finland.
Phone: +358 10 22 11

declare under our sole responsibility that the following products:

Frequency converters

ACS880-01/-11/-31

ACS880-04/-04F/-M04/-14/-34

with regard to the built-in safety function:

Safe torque off;

and with regard to the following optional safety functions with FSO-12 module (option code +Q973, encoderless):

**Safe stop 1; Safe stop emergency; Safely-limited speed; Safe maximum speed;
Safe brake control; Prevention of Unexpected Start-up;**

and with regard to the following optional safety functions with FSO-21 and FSE-31 modules (option codes +Q972 and +L521):

**Safe stop 1; Safe stop emergency; Safely-limited speed; Safe maximum speed;
Safe brake control; Safe speed monitor; Safe direction; Prevention of
Unexpected Start-up;**

and with regard to the following optional safety function with FPTC-01 thermistor protection module (option code +L536):

Safe Motor Temperature;

are in conformity with all the relevant safety component requirements of EU Machinery Directive 2006/42/EC, when the listed safety functions are used for safety component functionality.



The following harmonized standards have been applied:

EN 61800-5-2:2007	<i>Adjustable speed electrical power drive systems – Part 5-2: Safety requirements - Functional</i>
EN 62061:2005 + AC:2010 + A1:2013 + A2:2015	<i>Safety of machinery – Functional safety of safety-related electrical, electronic and programmable electronic control systems</i>
EN ISO 13849-1:2015	<i>Safety of machinery – Safety-related parts of control systems. Part 1: General requirements</i>
EN ISO 13849-2:2012	<i>Safety of machinery – Safety-related parts of the control systems. Part 2: Validation</i>
EN 60204-1: 2006 + A1:2009 + AC:2010	<i>Safety of machinery – Electrical equipment of machines – Part 1: General requirements</i>

The following other standards have been applied:

IEC 61508:2010	Functional safety of electrical / electronic / programmable electronic safety-related systems
IEC 61800-5-2:2016	Adjustable speed electrical power drive systems – Part 5-2: Safety requirements - Functional

The products referred in this Declaration of conformity fulfil the relevant provisions of other European Union Directives which are notified in Single EU Declaration of conformity 3AXD10000497831.

Person authorized to compile the technical file:

Name and address: Ari Korpela, Hiomotie 13, 00380 Helsinki, Finland.

Helsinki, 29 Jan 2018

Manufacturer representative:

Vesa Kandell
Vice President, ABB Oy



EU Declaration of Conformity

Machinery Directive 2006/42/EC

We

Manufacturer: ABB Oy

Address: Hiomatie 13, 00380 Helsinki, Finland.

Phone: +358 10 22 11

declare under our sole responsibility that the following products:

Frequency converters and frequency converter components

ACS880-04, -14, -34 (frames nxR8i)

ACS880-04XT

ACS880-07

ACS880-17, -37 (frames R11 and nxR8i)

ACS880-104, -107

ACS880 multidrives

ACS880-104LC (frames nxR8i)

Identified with serial numbers beginning with 1 or 8

with regard to the safety functions

Safe torque off

Safe motor temperature with FPTC-01 module (option code +L536)

Safe stop 1, Safe stop emergency, Safely-limited speed, Safe maximum speed, Safe brake control, Prevention of unexpected start-up, with FSO-12 module (option code +Q973)

Safe stop 1, Safe stop emergency, Safely-limited speed, Safe maximum speed, Safe brake control, Safe Speed monitor, Safe direction, Prevention of unexpected start-up, with FSO-21 and FSE-31 modules (option codes +Q972 and +L521)

ACS880-07, -17, -37 and ACS880 multidrives: Prevention of unexpected start-up (option codes +Q950; +Q957), Emergency stop (option codes +Q951; +Q952; +Q963; +Q964; +Q978; +Q979), Safely-limited speed (option codes +Q965; Q966)

are in conformity with all the relevant safety component requirements of EU Machinery Directive 2006/42/EC, when the listed safety functions are used for safety component functionality.



The following harmonized standards have been applied:

EN 61800-5-2:2007	Adjustable speed electrical power drive systems – Part 5-2: Safety requirements - Functional
EN 62061:2005 + AC:2010 + A1:2013 + A2:2015	Safety of machinery – Functional safety of safety-related electrical, electronic and programmable electronic control systems
EN ISO 13849-1:2015	Safety of machinery – Safety-related parts of control systems. Part 1: General principles for design
EN ISO 13849-2:2012	Safety of machinery – Safety-related parts of the control systems. Part 2: Validation
EN 60204-1:2006 + A1:2009 + AC:2010	Safety of machinery – Electrical equipment of machines – Part 1: General requirements

The following other standard has been applied:

IEC 61508:2010	Functional safety of electrical / electronic / programmable electronic safety-related systems
----------------	---

The products referred in this Declaration of conformity fulfil the relevant provisions of other European Union Directives which are notified in Single EU Declaration of conformity 3AXD10000497305.

Person authorized to compile the technical file:

Name and address: Vesa Tiihonen, Hiomotie 13, 00380 Helsinki, Finland

Helsinki, 13 Oct 2017

Manufacturer representative:

Peter Lindgren
Vice President, ABB Oy

Note: If the Declaration of Conformity is needed in any other official language of European Union than in English, contact ABB.

TÜV Nord certificate

TÜV Nord certificate for the FPTC-01 module and ACS880 drive series is attached below.



Certificate

No. SEBS-A.095524/15 V1.0

TÜV NORD Systems GmbH & Co. KG hereby certifies

ABB Oy
Hiomotie 13
00381 Helsinki
Finland

that the
FPTC-01

as a plug-in module for the ABB industrial drive ACS880 series

with the safety function Safe Motor Temperature (SMT) meets the requirements listed in the following standards

- IEC 61508 part 1:2010; part 2:2010; capable up to SIL 2
- ISO 13849-1:2006, ISO 13849-2:2012; capable up to PL c (category 1)
- IEC 61800-5-2:2007; capable up to SIL 2
- IEC 62061:2015; capable up to SIL_{CL} 2

The module can also be used in safety applications up to SIL 2 according to IEC 61511-1:2004

Base of certification is the report SEBS-A.095525/15TB in the valid version.

This certificate entitles the holder to use the pictured safety approved mark.

Expiry date: 2020-11-27
Reference No: 8112238954

Hamburg, 2015-11-27

T. Nelke



Certification Body SEECERT
TÜV NORD Systems GmbH & Co. KG
Große Bahnstraße 31, 22525 Hamburg, Germany











Further information

Product and service inquiries

Address any inquiries about the product to your local ABB representative, quoting the type designation and serial number of the unit in question. A listing of ABB sales, support and service contacts can be found by navigating to www.abb.com/searchchannels.

Product training

For information on ABB product training, navigate to new.abb.com/service/training.

Providing feedback on ABB manuals

Your comments on our manuals are welcome. Navigate to new.abb.com/drives/manuals-feedback-form.

Document library on the Internet

You can find manuals and other product documents in PDF format on the Internet at www.abb.com/drives/documents.

Contact us

www.abb.com/drives

www.abb.com/drivespartners



3AXD50000027750C

3AXD50000027750 Rev C (EN) 2018-03-23

Power and productivity
for a better world™

