

Technical manual BA 0509



Filling level

KAK / KLK

Filling level limit switch

for conductive filling level supervision
in electrical conductive liquids

Detects up to two limit values

Useable

- for filling level resp. limit value detection in liquid container
- as overflow protection in container
- as dry run protection for pumps in pipelines
- for two-position-control in plants

Wide application range

- for process temperatures from -40 °C to +100 °C
- for process pressures from -1 bar to +10 bar
- materials for aggressive filling liquids

Measuring range adjustable up to 200k Ω resp. 5 μ S/cm

Wide range power supply from 20 to 253V AC and DC

Relay output or PNP switching output

ACS-CONTROL-SYSTEM
know how mit system



Lauterbachstr. 57 – 84307 Eggenfelden – Germany
Tel: +49 8721/9668-0 – Fax: +49 8721/9668-30
info@acs-controlsystem.de – www.acs-controlsystem.de

Index

Application field	3
Function	3 / 4 / 5
Safety notes	6
Installation	6 / 7
Maintenance	7
Repair	7
Electrical connection	8
Operation and display elements	9
Technical data	10 / 11
Dimension drawings	12 / 13 / 14 / 15
Order code overview	16

Application field

The filling level limit switch **KAK** resp. **KLK** is used, to evaluate one or two filling levels resp. limit levels in electrically conductive liquids with a conductivity of minimum $5\mu\text{S}/\text{cm}$ resp. a resistance of maximum $200\text{k}\Omega$.

The device is also useable as overflow protection in container with liquids, for the realization of a two-position-control e.g. for pump control or also as dry run protection.

The conductivity also of aggressive filling liquids can be detected, at process temperatures from $-40\text{ }^{\circ}\text{C}$ to $+100\text{ }^{\circ}\text{C}$, at pressures from -1 bar to $+10\text{ bar}$.

The version **KAK** is the standard type for general applications, whereas the version **KLK** is especially conceived for food applications.

The following variants are available:

- Relay output version with wide range power supply from $20\dots253\text{V}_{\text{AC/DC}}$, for two-channel or Δs mode with two relay changeover contacts, resp.
- Relay output version with wide range power supply from $20\dots253\text{V}_{\text{AC/DC}}$, for one-channel or Δs mode with two relay changeover contacts, resp.
- Switching output version with direct voltage power supply $24\text{V}_{\text{DC}} \pm 10\%$, for one-channel or Δs mode with one PNP switching output.

Function

Measuring principle

The filling level limit switch **KAK** resp. **KLK** is mounted in the wall of the container or of the pipe by using the respective process connection or installed over the filling liquid by using a suitable mount.

The alternating voltage, that is generated by the integrated electronic is than applied either between the electrode rods or between the electrode rods and the metallic wall of the container resp. pipe that is connected to the metallic process connection.

Due to the use of a alternating voltage the corrosion at the electrode rod and the electrolytic decomposition of the filling liquid is avoided.

As soon as the electrically conductive filling liquid makes a connection between the electrodes resp. between the electrode and the metallic wall of the container resp. pipe, an alternating current flows, that causes a decrease of the alternating voltage.

Signal evaluation

An evaluation circuit supervises this alternating voltage. A voltage drop is detected and the evaluation circuit switches the relay resp. relays resp. the PNP switching output, depending on the set safety function.

The switching state of the output resp. outputs is indicated at the top side of the device by two yellow resp. at the version with PNP switching output by one red LED's.

Switching delay

In some applications it is necessary to compensate heavy signal fluctuations that may be produced by mixing machines or at fill-in resp. emptying of containers, to avoid spurious switching actions.

The device is equipped with a switching delay of one second.

This delay time effects both channels separately, at activation and deactivation of the output signals.

Sensitivity range

For the adjustment of the response threshold to the conductivity of the liquid the filling level limit switch can be adjusted by a multi-turn-trimmer

The detectable resistance is from $0\ \Omega$ and $200,0\ \text{k}\Omega$ resp. $5\mu\text{S}/\text{cm}$ at the relay output version resp. $0\ \Omega$ and $100,0\ \text{k}\Omega$ resp. $10\mu\text{S}/\text{cm}$ at the PNP switching output version.

Safety function – version with relay output

The safety function defines the operation principle of the relays.

- Maximum safety: The relay switches off, if the switching level is transgressed, (liquid connection between measuring and reference electrode) or the power supply fails.
- Minimum safety: The relay switches off, if the switching level is underrun, (no liquid connection between measuring and reference electrode) or the power supply fails.

	Minimum safety			Maximum safety		
	output relay S1	output relay S2*	LED	output relay S1	output relay S2*	LED
			● yellow S1 ● yellow S2*			☀ yellow S1 ☀ yellow S2*
			● yellow S1 ☀ yellow S2*			☀ yellow S1 ● yellow S2*
			☀ yellow S1 ☀ yellow S2*			● yellow S1 ● yellow S2*

For both channels, CH1 and CH2, the safety function can be set separately. This can be carried out by two jumper, one per channel, inside the housing of the device.

Two-position-control Δs (pump control) – version with relay output

The activation of the two-position-control for the output relay S1 is made by a switch inside the device. The output relay S2* continues operation in limit value mode.

Two-position-control – minimum safety				Two-position-control – maximum safety					
filling level	output relay S1	output relay S2*	LED		filling level	output relay S1	output relay S2*	LED	
			S1	S2*				S1	S2*
			●	●				☀	☀
			●	☀ yellow				☀ yellow	●
			☀ yellow	☀ yellow				●	●
			☀ yellow	☀ yellow				●	●
			●	●				☀ yellow	☀ yellow

* The relay S2 is only available at the version UC (wide range power supply with 2x relay output)

Safety function – version with PNP switching output

The safety function defines the operation principle of the PNP switching output.

- Maximum safety: The output signal switches off, if the switching level is transgressed, (liquid connection between electrode CH1 and reference electrode) or the power supply fails.
- Minimum safety: The output signal switches off, if the switching level is underrun, (no liquid connection between electrode CH1 and reference electrode) or the power supply fails.

	Minimum safety		Maximum safety	
	PNP switching output	LED	PNP switching output	LED
	Out (switch closed)	● red	Out (switch open)	☀ red
	Out (switch closed)	● red	Out (switch open)	☀ red
	Out (switch open)	☀ red	Out (switch closed)	● red

This respective safety function is set by a jumper inside the housing of the device.

Two-position-control Δs (pump control) – version with PNP switching output

The two-position-control function is always active.

Two-position-control – minimum safety

filling level	PNP switching output	LED red
	Out (switch closed)	●
	Out (switch closed)	●
	Out (switch open)	☀
	Out (switch open)	☀
	Out (switch closed)	●

Two-position-control – maximum safety

filling level	PNP switching output	LED red
	Out (switch open)	☀
	Out (switch open)	☀
	Out (switch closed)	●
	Out (switch closed)	●
	Out (switch open)	☀

Safety notes



Each person that is engaged with inauguration and operation of this device, must have read and understood this technical manual and especially the safety notes.

Installation, electrical connection, inauguration and operation of the device must be made by a qualified employee according to the informations in this technical manual and the relevant standards and rules.

The device may only be used within the permitted operation limits that are listed in this technical manual. Every use besides these limits as agreed can lead to serious dangers.

The materials of the device must be chosen resp. checked for suitability to the respective application requirements (contacting substances, process temperature). An unsuitable material can lead to damage, abnormal behavior or destruction of the device and to the resulting dangers.

The device meets the legal requirements of all relevant EC directives. 

Installation

Shortening of the electrode rods

Before the installation into the plant the electrode rods must be shortened acc. to the needed filling level limits. The numbering that is stamped at the bottom side of the process connection gives an information for the function of the respective rod.

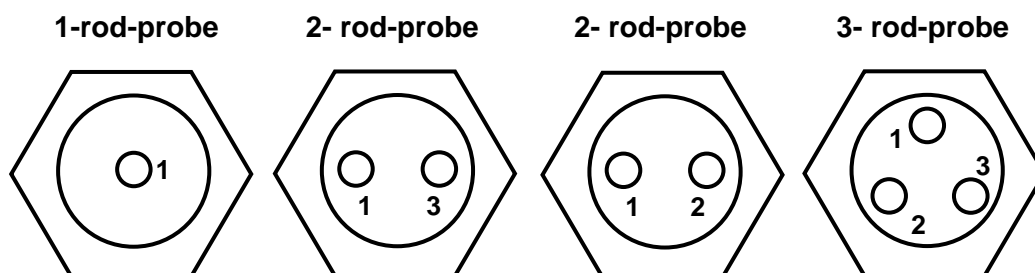

Function	Numbering	Numbering	Numbering	Numbering
CH1 (for $\Delta s \rightarrow$ shortest rod)	1	1	1	1
CH2 (for $\Delta s \rightarrow$ longest rod)	not available	not available	2	2
reference electrode (for 3-rod \rightarrow longest rod)	by process connection thread	3	by process connection thread	3

The isolation of the electrode rod may not be damaged resp. removed excepted at the electrode tip.

The electrode rods can be shortened arbitrary by a tong or a saw

After shortening the electrode rod remove at least 10 mm of the isolation.

At shortening the electrode may not be stressed mechanically to avoid damaging of the isolation.

Installation

Drive the system pressure free prior installation resp. deinstallation of the sensor and avoid high temperatures to avoid injuries.

Consider enough installation space outside the container or the pipeline to insert the filling level limit switch into the plant without the use of force.

Install the device if necessary into a bypass if dense heavy foam, wild turbulences or foamed liquids can occur.

Install the filling level limit switch in such a position in the container, where no strong forces to the side, like e.g. by mixer or near fill-in openings, can have an effect to the electrode rods.

This is especially important for filling level limit switches with especially long electrode rods.

If a metallic wall of a container resp. pipeline should be used as reference electrode there must be paid attention that the metallic process connection of the filling level limit switch is safe electrically conductive connected with the container resp. the pipeline. Use conductive gaskets like e.g. copper or lead. Isolation measures like e.g. the wrap of the thread with teflon band or a paper gasket can interrupt the electric contact.

The non-isolated tips of the electrode rods, when mounted, may not make a contact to the wall of the container, if this is made of metal or electrically conductive plastic.

Electrode rods longer than 0,5 m must be stabilized among each other or against the wall of the container, especially if the filling liquid is strongly fluctuating.

Use for the stabilization suitable spacers.

The distance between the spaces should be not more than 0,5 m.

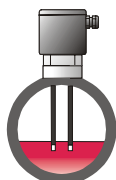

At horizontal pipelines the length of the electrodes is limited by that way, that in a empty pipe, also in the case of liquid residues, the electrically conductive liquid connection between electrode and wall resp. between the two electrode rods can disconnect. Otherwise an empty pipe can be detected as filled.

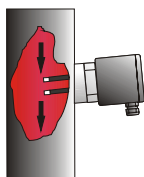

At horizontal side mounting into a container or also into a pipe for stability reasons the length of the electrode rods should be not more than 200 mm.

At electrode rods with diameter 8 mm the length can be longer.

At a horizontal mounting the electrode rods should be installed at an angle with the electrode rod tip below (approx. 20...30°), to allow an easier flow-off of filling material residues and by this to avoid the coat-forming.

The tightening of the process connection may only be done at the hexagon by a suitable spanner.

The maximum permitted torque strength is 50 Nm.

The screw in of the process connection by using the connection housing is not permitted.

Maintenance

The device is free of maintenance.

The isolation of the electrodes should be checked regularly and also a possible coating at the electrode rods should be removed.

A non-conductive coating at the metallic electrode tip can effect error behaviour because no current can flow although the electrically conductive filling liquid makes a connection.

Repair

A repair may only be carried out by the manufacturer.

If the device must be sent back for repair, the following informations must be enclosed:

- An exact description of the application.
- The chemical and physical characteristics of the product.
- A short description of the occurred error.

Before returning the device for repair, the following measures must be proceeded:

- All stick product residues must be removed. This is especially important, if the product is unhealthy, e.g. caustic, toxic, carcinogenic, radioactive etc.
- A returning must be refrained, if it is not possible by 100% to remove the unhealthy product completely, because e.g. it is penetrate into cracks or is diffused through plastic.

Electrical connection

The electrical connection of the device must be carried out according to the respective country specific standards. Incorrect installation or adjustment could cause applicationally conditioned risks.

Use only suitable cables with max. 25 Ω per wire, that fulfills the requirements e.g. regarding temperature, resistance or laying at the place of installation.

The cable gland is suitable for cable diameters from 4 to 10 mm. After installation of the cable the cable gland must be fix screwed to ensure the tightness of the connection housing.

For inauguration it is suggested to switch off all connected control devices to avoid unintended control actions.

Version with relay output

Power supply input, electrode circuit and the two relay outputs are safe galvanically isolated from each other.

Due to the integrated wide range power supply, for connection to supply voltages from 20...253V AC / DC, the filling level limit switch is suitable for using in all common energy supply networks.

The connection is reverse polarity protected.

A fuse is integrated internally at the power supply circuit. Due to this the installation of a fine protection is not necessary.

Inductive loads at the relay contacts, e.g. auxiliary contactors or magnetic vents may only be used with a free-wheeling diode or a RC protection circuit to avoid high voltage peaks.

Version with PNP switching output

The power supply voltage and the PNP switching output are galvanically separated from the electrode circuit.

The power supply voltage may not exceed 27 V to avoid damage of the electronic.

The power supply voltage connection is polarity protected.

The load at the PNP switching output will be connected contactless and by this bounce-free to the positive terminal of the power supply voltage by a semiconductor switch. At activated switching state a positive signal near power supply voltage is produced at the terminal Out.

At deactivated switching state and at failure of power supply voltage the semiconductor switch is shut off.

The PNP switching output is current limited to 0,5 A.

Inductive loads at the PNP switching output, e.g. relays or contactors may only be used with a free-wheeling diode or a RC protection circuit to avoid high voltage peaks.

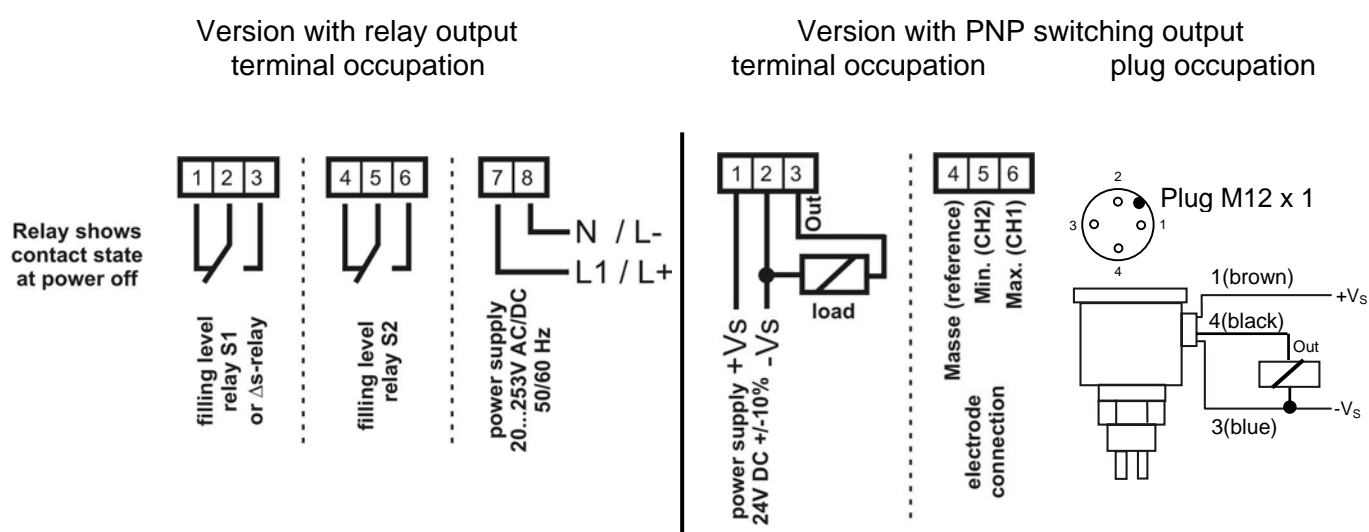

* The relay S2 is only available at the version UC (wide range power supply with 2x relay output)

Operation and display elements

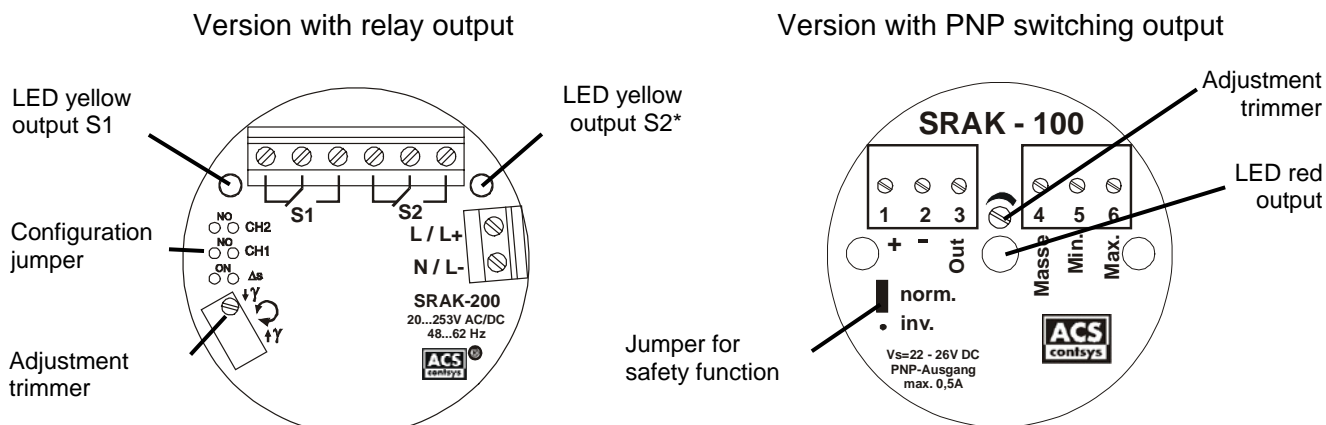

Function indicator

- yellow LED → output relay S1 switched on only at version with relay output
- yellow LED → output relay S2* switched on only at version with relay output
- red LED → PNP switching output active only at version with PNP switching output

Adjustment trimmer

For fine adjustment of the response sensitivity within the sensitivity range.

A turn to the right leads to a switching reaction at the output relays resp. PNP switching output at a higher liquid resistance resp. lower conductivity.

For adjustment proceed like follows:

- Liquid must create an electrically conductive connection between measuring and reference electrode
- Turn adjustment trimmer to the left (counterclockwise), till the output switches off
- Turn adjustment trimmer to the right (clockwise), till the output switches on
- Turn adjustment trimmer by an additional half turn to the right (clockwise)

Configuration jumper – only at version with relay output

- CH 1 Safety function channel 1 (CH1)
- Maximum safety = jumper plugged NO – normally open
 - Minimum safety = jumper open NC – normally closed
- CH 2 Safety function channel 2 (CH2)
- Maximum safety = jumper plugged NO – normally open
 - Minimum safety = jumper open NC – normally closed
- Δs Relay function output relay S1
- Limit value function CH1 = Jumper open OFF
 - Two-position control Δs = Jumper plugged ON
- At two-position-control Δs both jumper for the safety function channel 1 and channel 2 (CH1 and CH2) must be set identically

Jumper – only for version with PNP switching output

- Safety function
- Maximum safety = Norm.
 - Minimum safety = Inv.

* The relay S2 is only available at the version UC (wide range power supply with 2x relay output)

Technical data

Auxiliary supply

Version with relay output

Supply voltage:	20 V to 253 V AC / DC 48...62 Hz	reverse polarity protected
Power consumption:	≤ 1,75 VA / 1 W	
Overvoltage category:	II	acc. to DIN EN 61010-1
Protection classification:	II	double or reinforced insulation
Isolation voltage:	2,5kV~	auxiliary power to relay outputs to electrode circuit

Version with PNP switching output

Supply voltage:	24 V DC ±10%	reverse polarity protected
Ripple voltage:	≤ 0,5 V _{PP}	condition: within the permitted supply voltage range
Power consumption:	≤ 1 W	PNP switching outputs with no load
Overvoltage category:	II	acc. to DIN EN 61010-1
Protection classification:	II	double or reinforced insulation
Isolation voltage:	1kV~	auxiliary power / PNP switching output to electrode circuit

Relay output

Function:	1x resp. 2x potential-free changeover contact	
Switching power of the contacts:	≤ 250 Vac / 220 Vdc – 2 A – 62,5 VA / 60 W (at ohmic load) ≥ 100 μV	
Delay time:	1 second	
Switching cycles:	≥ 100.000	at maximum contact load

PNP switching output

Function:	PNP switching to +Vs	
Output voltage:	V _{OUT} ≥ +V _s – 2 V	
Output current:	≤ 500 mA	current limited, short circuit protected
Rise up time:	< 30 μs	
Delay time:	1 second	
Switching cycles:	≥ 100.000.000	

Electrode circuit

Output voltage:	potential-free alternating voltage	
Output values:	9 V _{SS} ± 1 V / ≤ 90 Hz ± 15 Hz / ≤ 1,5 mA	
Measuring range:	≤ 200 kΩ resp. ≥ 5 μS/cm	at version with relay output
	≤ 100 kΩ resp. ≥ 10 μS/cm	at version with PNP switching output

Measuring accuracy

Temperature deviation:	≤ 0,5% of the measuring range / 10 K
------------------------	--------------------------------------

Technical data

Materials

Electrode rod: (medium contact)	steel 1.4404 (AISI 316L) / 1.4571 (AISI 316Ti) / hastelloy B / hastelloy C / titan
Electrode isolation: (medium contact)	PA – polyamide / E-CTFE – ethylene-chlorotrifluorethylene (Halar [®])
Process connection: (medium contact)	steel 1.4404 (AISI 316L) / 1.4571 (AISI 316Ti)
Connection housing:	CrNi-steel / POM – polyoxymethylene (Delrin [®]) / PP – polypropylene / PTFE – polytetrafluorethylene (Teflon [®])
Connection housing cap:	CrNi-steel at connection housing steel PC – polycarbonate (Makrolon [®]) at connection housing POM / PP / PTFE
Cable gland:	CrNi-steel at connection housing steel PA – polyamide at connection housing POM / PP / PTFE
Device plug M12x1:	socket CrNi-steel, insert PUR, contacts gold-plated
Gaskets:	medium contact → FPM – fluorelastomere (Viton [®]) EPDM – etylene-propylene-dienmonomere other → FPM – fluorelastomere (Viton [®]) silicone

Environmental conditions

Environmental temperature:	– 40°C...+85°C		
Process temperature:	– 40°C...+100°C		
Process pressure range:	– 1 bar ...10 bar		
Weight:	housing	steel PTFE / POM / PP	0,5 kg 0,2 kg
	electrode rod	diameter 4 mm diameter 8 mm	0,1 kg / 1000 mm 0,4 kg / 1000 mm
Torque strength:	≤ 80 Nm		
Protection classification:	IP68	DIN EN 60529	IP 65 at connection plug M12
EM – compatibility:	emission immunity	DIN EN 61326-1 DIN EN 61326-1	operation device class B industrial range

Operation

Indication limit value:	1 resp. 2 LED, yellow 1 LED, red	at version with relay output at version with PNP switching output
Configuration:	3 jumper 1 jumper	at version with relay output at version with PNP switching output
Sensitivity adjustment:	1 trimmer 12-turn 1 trimmer 20-turn	at version with relay output at version with PNP switching output

Connection terminals

Version with relay output

Number:	8 terminals, everlasting screws
Connection cross-section:	maximum 1x 1,5 mm ² rigid / flexible

Version with PNP switching output

Number:	3 terminals, everlasting screws
Connection cross-section:	maximum 1x 2,5 mm ² rigid / flexible

Dimension drawing KAK

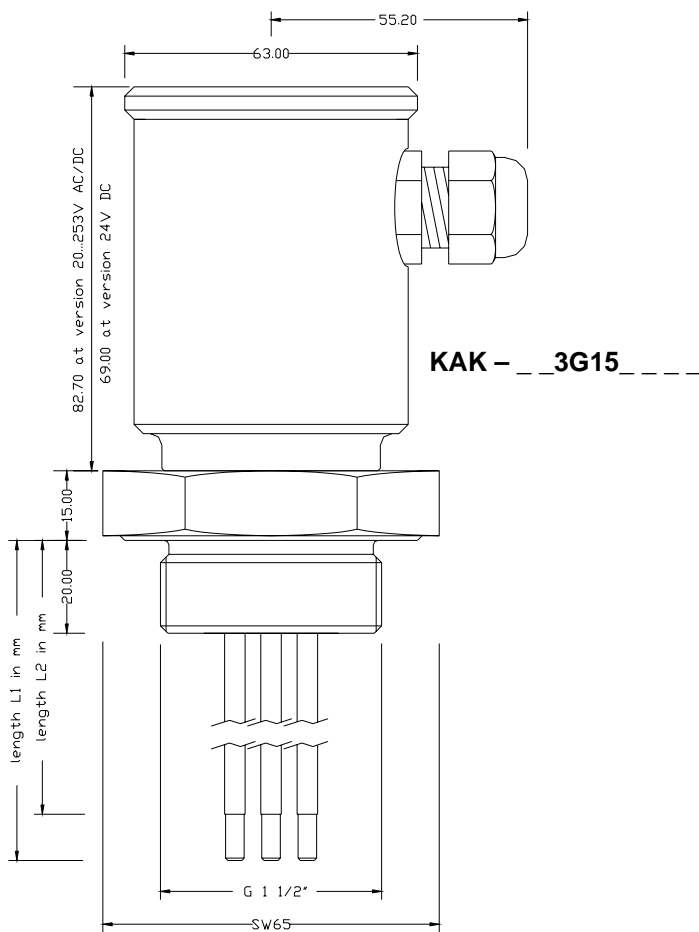
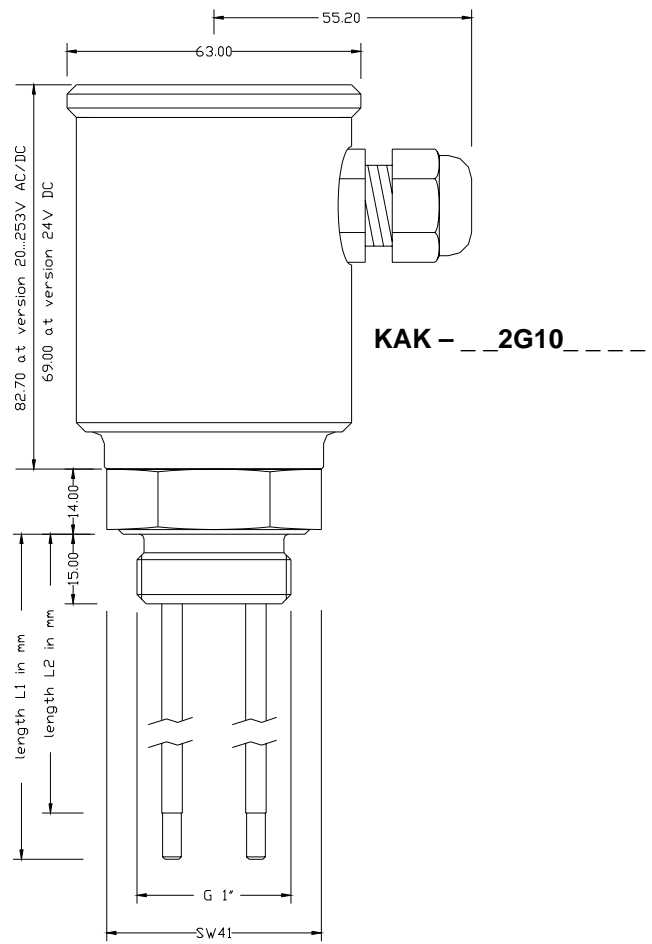
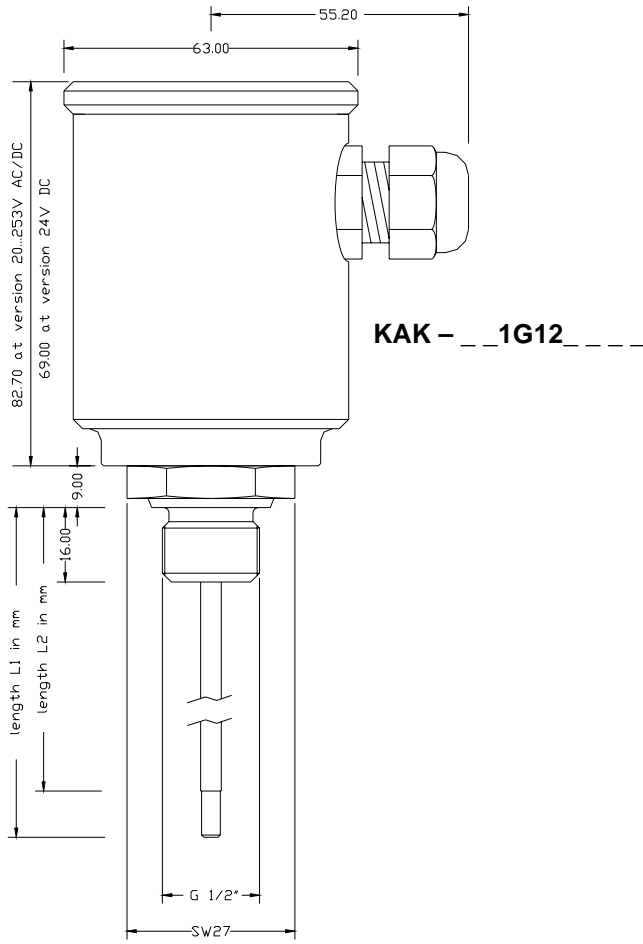

Dimension drawing KLK

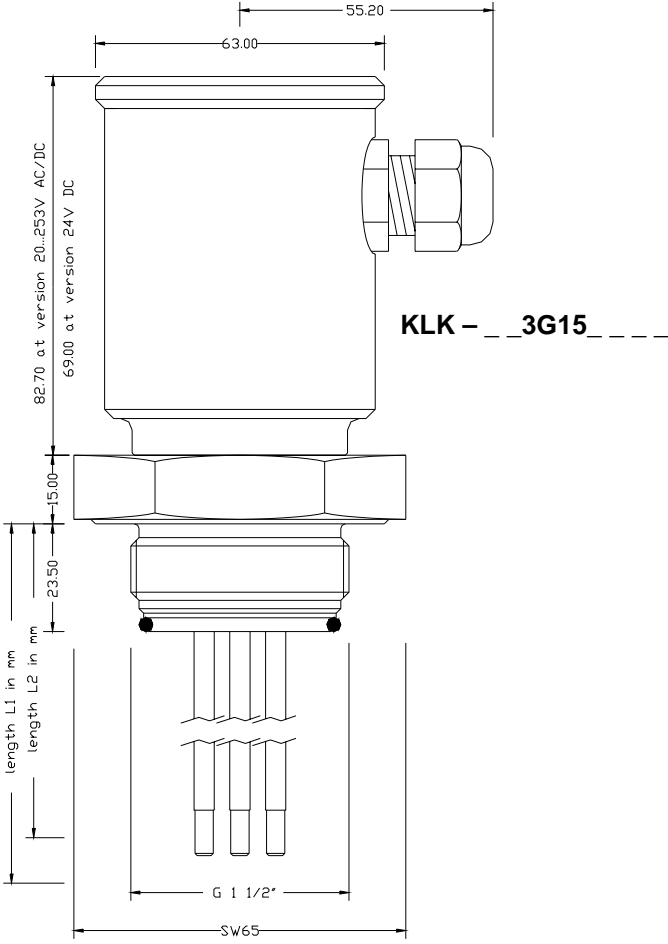
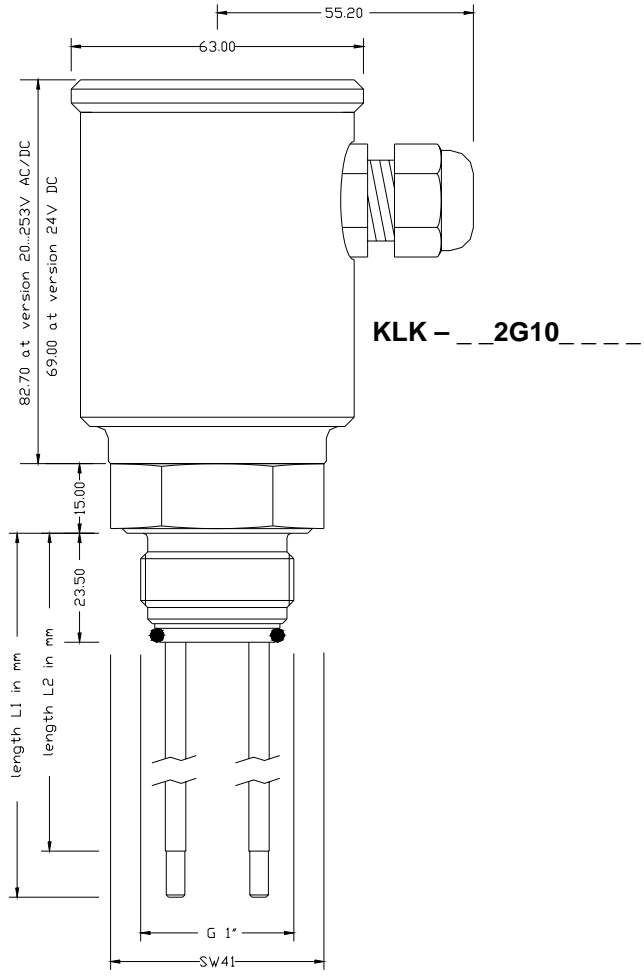
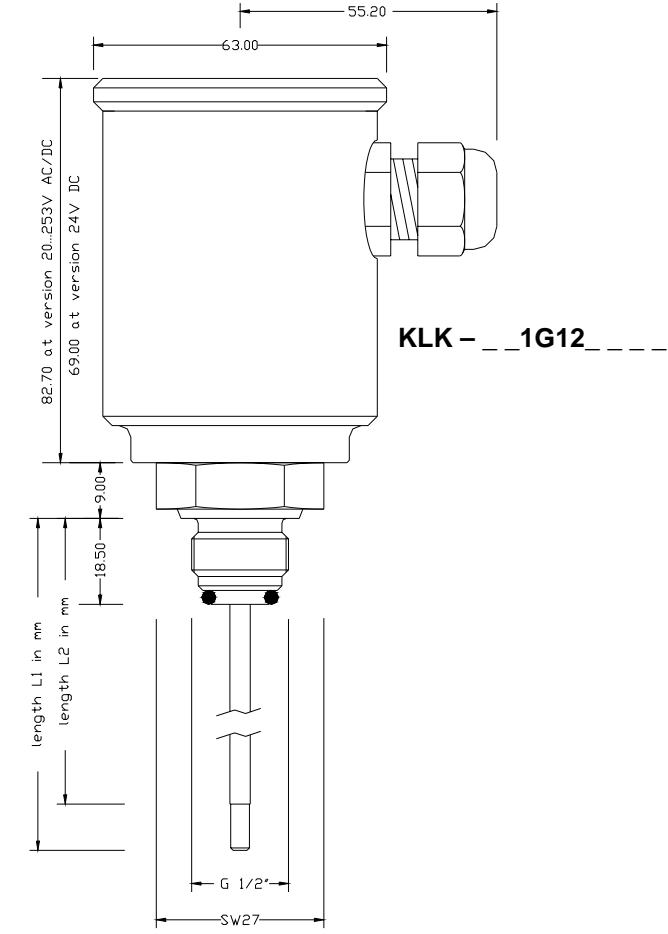

Dimension drawing KLK

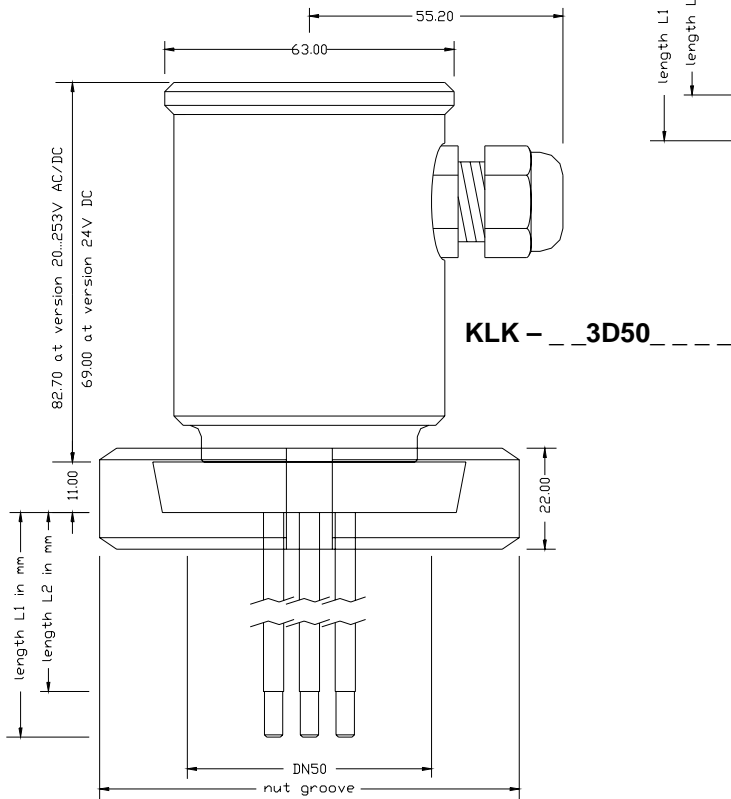
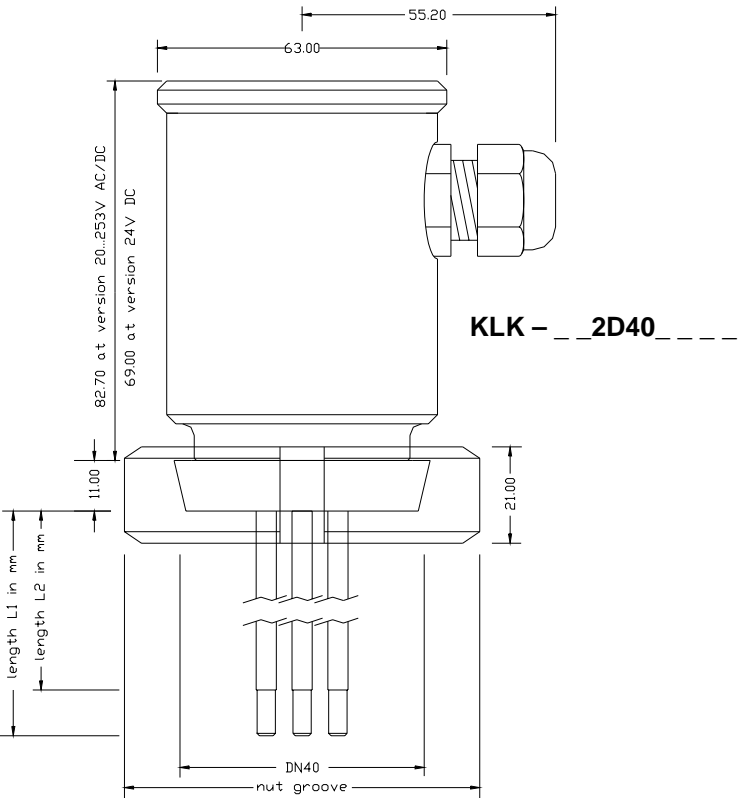
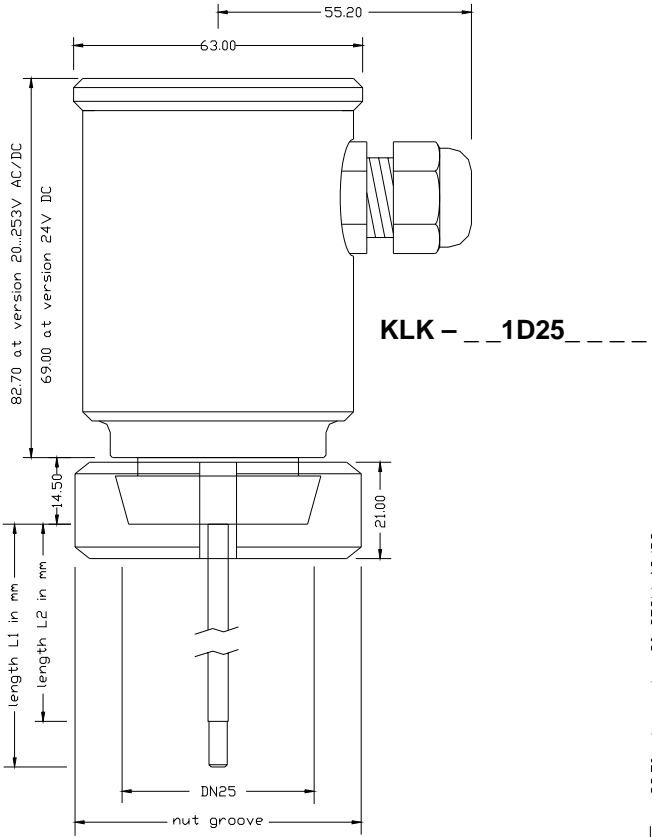

Dimension drawing welding sleeves

SEM12 for KLK G1/2"

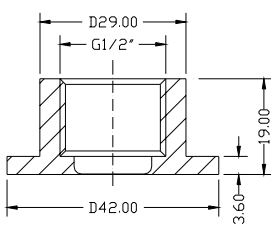

SEM10 for KLK G1"

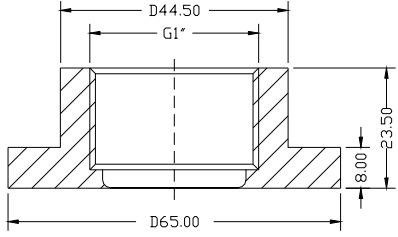

SEM15 for KLK G 1 1/2"

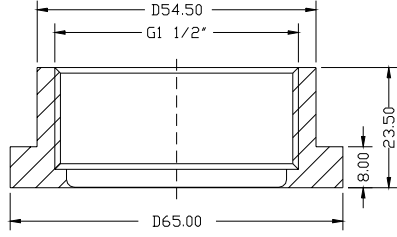

**BEFC-62 for KLK DN25
acc. to DIN 11851**

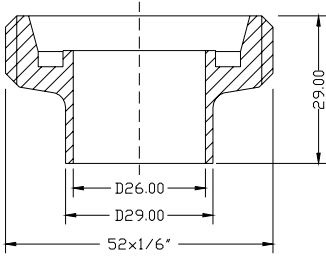

**BEFB-62 for KLK DN40
acc. to DIN 11851**

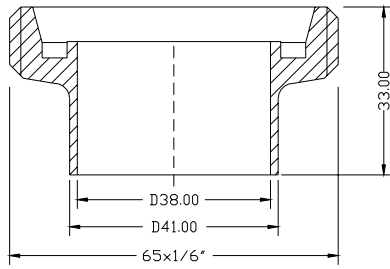

**BEFA-62 for KLK DN50
acc. to DIN 11851**

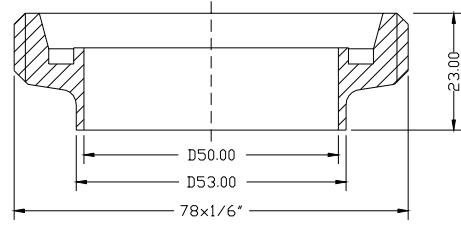

Order code overview

Type
KAK
KLK

Standard
 Food applications

Electrical connection

- Terminal box
 V Plug M12 x 1 only at auxiliary power direct voltage 24 V DC

Auxiliary power

G Direct voltage 24 V DC
 U Wide range power supply 20...253 V AC/DC

Output

A 1 x PNP switching output only at auxiliary power direct voltage 24 V DC
 B 1 x relay output only at auxiliary power wide range power supply 20...253 V AC/DC
 C 2 x relay output only at auxiliary power wide range power supply 20...253 V AC/DC

Type measuring system

1 1-rod 1x limit value reference electrode by process connection
 2 2- rod 1x limit value reference electrode by longest rod - number 3
 3 3- rod 1x resp. 2x limit value / Δs reference electrode by longest rod - number 3
 4 2- rod 1x resp. 2x limit value / Δs reference electrode by process connection

Process connection material steel 1.4404 / 1.457 (medium contact)

G12 G ½ " DIN EN ISO228-1 for 1-rod
 G10 G 1 " DIN EN ISO228-1 for 2-rod
 G15 G 1 ½ " DIN EN ISO228-1 for 3-rod
 D25 Milk tube DN 25, PN 40 DIN 11851 for 1-rod only for version KLK
 D40 Milk tube DN 40, PN 40 DIN 11851 for 2-rod only for version KLK
 D50 Milk tube DN 50, PN 40 DIN 11851 for 3-rod only for version KLK
 YYY others on request

Material electrode rod (medium contact)

A Steel 1.4404 / 1.4571 standard
 C Hastelloy B only for rod diameter 4 mm
 D Hastelloy C only for rod diameter 4 mm
 T Titan only for rod diameter 4 mm
 E Steel 1.4404 / 1.4571– Tip Tatalum 50mm on request
 Y others on request

Material connection housing

D POM – polyoxymethylene (Delrin®) standard for KAK
 P PP – polypropylene standard for KLK
 L PTFE – polytetrafluorethylene (Teflon®)
 V CrNi-steel

Material electrode isolation (medium contact)

R PA – polyamide not for version KLK
 H E-CTFE – ethylene-chlorotrifluorethylene (Halar®)

Diameter electrode rod

- 4 mm standard
 W 8 mm

Length L1 electrode rod in mm, max. 3000 mm

Length L2 electrode isolation in mm, max. 3000 mm

KAK resp. KLK _ _ _ _ _