



Vibration level limit switch for liquids;  
Miniaturized small vibration fork  
Screw-in thread G½" und G¾"

## Description

Vibrocont SCM-300 is a point level switch for liquids. The Vibrocont SCM-300 is designed for industrial applications in all industries, mainly the machinery industry. The Vibrocont SCM-300 is used for overfill prevention or pump dry-run protection in cleaning and filter systems as well as in cooling and lubrication vessels.



## Application

- External test option using test magnet
- On-site control using external LED display

## Your benefits

- Compact: Smallest vibronic sensor
- Safe: Continuous self-monitoring and reliable switching independent of media properties
- Easy: no calibration or adjustment; plug & play
- Service-friendly plug-in connections
- For medium temperatures up to 150 °C



## Special

up to  
**40**  
bar  
pressure

**WHG**  
licence

corrosion  
resistant

compact  
design

Order code. . . . . page |04|

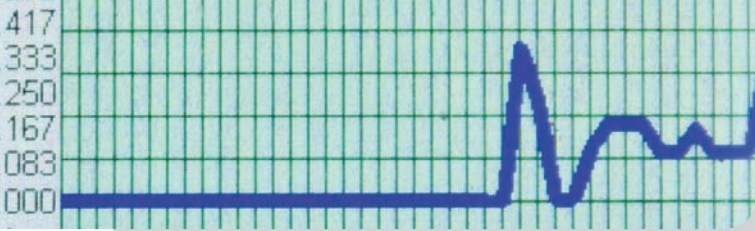

## Technical data

Technical data	
Measuring Principle:	Vibration Liquids
Characteristic / Application:	Level switch for liquids and is used in tanks, vessels and pipes.
Supply / Communication:	20 ... 253V AC/DC, 2-wire; 10 ... 35V DC-PNP 3-wire
Ambient temperature:	40 °C ... 70 °C (-40 °F ... 158 °F)
Process temperature: -	40 °C ... 150 °C (-40 °F ... 302 °F)
Process pressure absolute / max. over-pressure limit:	Vacuum ... 40 bar (Vacuum ... 580 psi)
Min. density of medium:	>0,7g/cm <sup>3</sup> (>0,5g/cm <sup>3</sup> optional)
Main wetted parts:	316L
Process connection Threads:	G1/2, G3/4, G1, MNPT1/2, MNPT3/4, MNPT1, R1/2, R3/4, R1
Output:	AC/DC, DC-PNP
Certificates / Approvals:	WHG; EN10204-3.1 material; Final Inspection Report
Options:	Adjustment switching delay; Cleaned from oil+grease, PWIS free

## Connection

Electronic: 3-wire-DC-PNP

Valve plug

M12

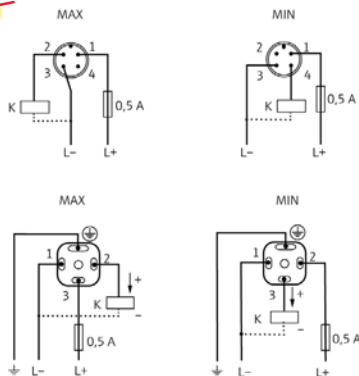

Electronic: 2-wire-AC/DC

Valve plug

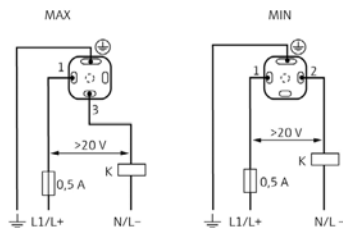

Compact version  
Thread ISO 228 G1/2", G3/4"

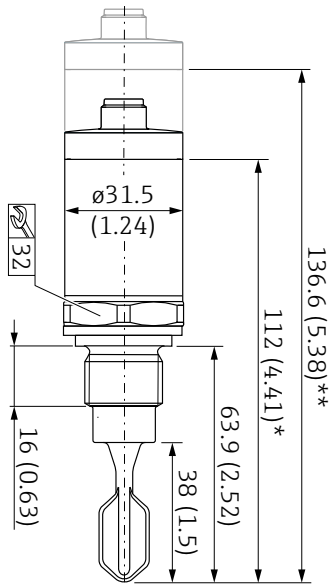

Compact version  
Thread ISO 228 G1"

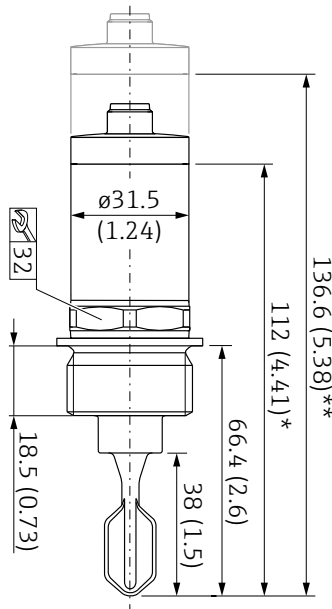

Compact version thread ISO  
228 G1" for flush wall  
installation in welding adapter

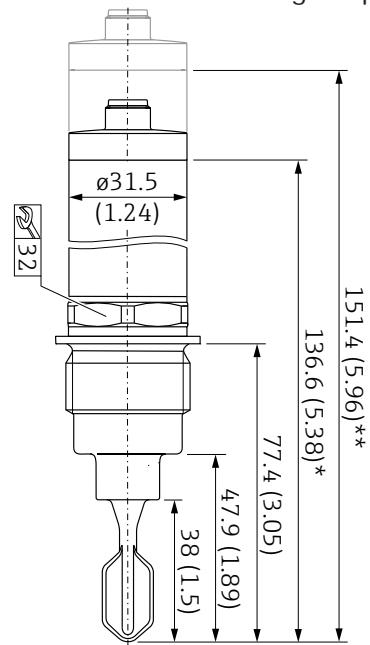

Short tube version  
Thread ISO 228 G1/2", G3/4"

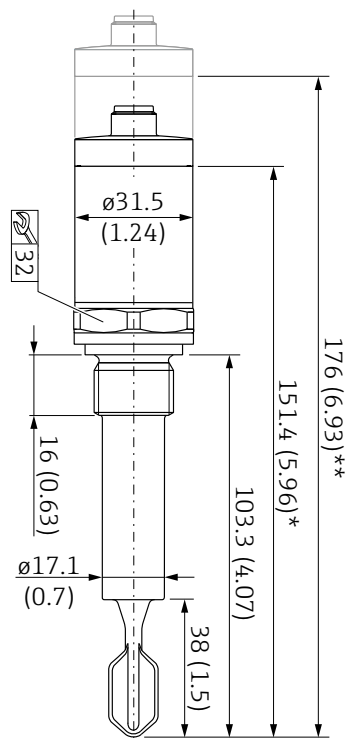

Short tube version  
Thread ISO 228 G1"

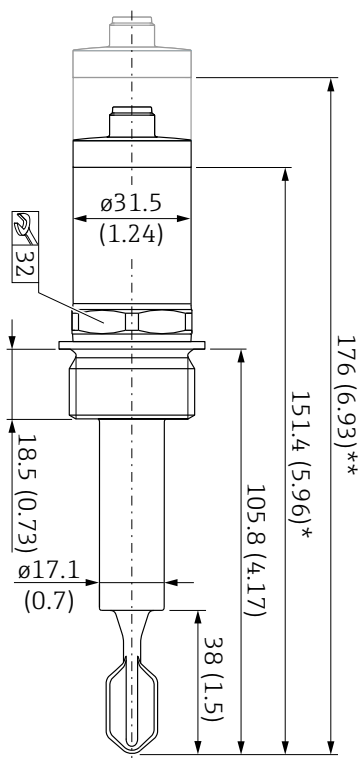

Short tube version thread ISO  
228 G1" for flush wall installati-  
on in welding adapter

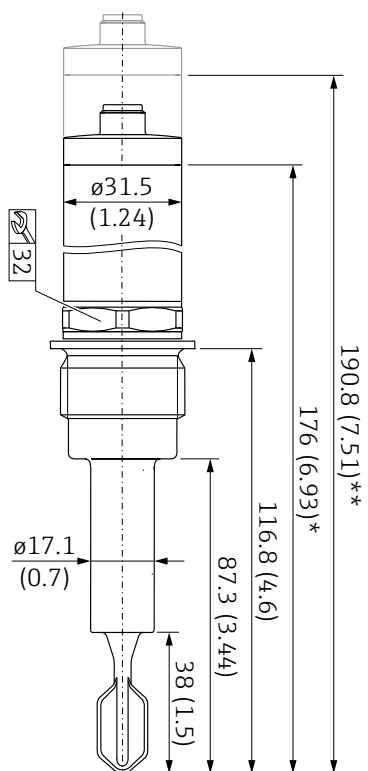

\* Dimensions for process temperature max. 100 ° C  
\*\* Dimensions for process temperature max. 150 ° C

# Order code

- 300 Standard admission 100°C
- 302 Overfill safety WHG + leakage detection 100°C process temperature
- 350 Standard admission 150°C
- 352 Overfill safety WHG + leakage detection 150°C process temperature

### Construction form

- K** Compact version
- R Probe extension: tube (= Switching point as VCL 200/202)
- Y Special version

### Process connection

- 2** Screw-in piece G½"
- 1 Screw-in piece G¾"
- 6 G1" B; DIN EN ISO228-1, flush mounting in welding socket BEFV-10 (= Process connection as VCL 200/202)
- 7 Screw-in piece G1"
- Y Special version

### Electronics

- WA Electronic: 20...253V AC/DC
- GA** Electronic: 10...30V DC
- Y Special version

### Electrical connection

- 02 Model: valve plug
- 01** Model: plug M12 (not for AC-Version)
- Y Special version

- S** Standard

Order code

<b>Vibrocont SCM</b>	<b>S</b>
----------------------	----------

## Equipment

Ordering designation	Type
BEF-SCM34	welding socket G¾"
LKW 0405 PUR	connection cable 5 m
LKW P405 PUR	connection cable LED 5 m
BKZ0412 VA	cable socket

Stand: 10/2016