



Supply Isolation Amplifier

AD-STVEX 710 GVD

Description

The supply isolation amplifier AD-STVEX 710 GVD is designed for operation of an intrinsically safe 2-wire measuring transducer (transmitter) and an mA current source installed in the hazardous area / potentially explosive atmosphere.

A 2-wire measuring transducer is supplied with power and the impressed analog 4-20 mA measuring signal is galvanically isolated and transmitted from the hazardous area / potentially explosive atmosphere to the non-hazardous area.

Alternatively, the passive input current circuit of the supply isolation amplifier detects the 0/4-20 mA measuring signal from a current source from the hazardous area / potentially explosive atmosphere and isolates it galvanically to make it available at the output of the device in the non-hazardous area. In this case, AD-STVEX 710 GVD operates as an isolation amplifier.

The device features a universal mains supply unit so it can be used with various supply voltages.



Special features

- Supply of a 2-wire transducer or measurement of an active 0/4-20mA current signal from the hazardous area / potentially explosive atmosphere zone 0
- Sensor error detection as per Namur NE43
- Output of the measurement signal to a current and voltage output
- Optional available with Ex input terminal at the bottom (order option: S-388)
- Measuring range, filter, etc. can be configured by the customer via AD-Studio
- 23 mm narrow housing with plug-type, coded connection terminals
- Zero and full scale by means of two front keys

Business data

Catalog number AD-STVEX 710 GVD
 AD-STVEX 710 GVD (S-388)
 Note: Ex input terminal at the bottom

Technical specifications

Current input

Measuring range 0/4-20 mA
 Input resistance 50 Ohm

Input supply voltage

at 4 mA approx. 23 V
 at 20 mA approx. 16 V

Current output

Output range 0-20 mA, 4-20 mA
 Maximum resistance 500 Ohm

Safety-related data

see operating manual

Voltage output

Output range 0-10 V
 Maximum resistance > 2 kOhm

Total accuracy

Linearity error < 0,2%
 Temperature influence < 100 ppm / K
 Response time < 100 ms

Supply

Supply voltage 20-120 VDC / 50-253 VAC
 Current input as supply isolation amplifier
 max. 75 mA at 24 VDC
 max. 15 mA at 230VAC

Housing

Dimension (WXHxD) 23x110x128mm
 Degree of protection IP 20 as per EN 60529
 Wire cross section max. 2,5 mm²
 Connection technology Plug-type screw terminals
 Mounting DIN rail (EN 50022)
 Weight approx. 101 g

Ambient conditions

Ambient temperature -20...+60°C

Approvals

ATEX  II (1) G [Ex ia Ga] IIC
 II (1) D [Ex ia Da] IIIC
 EX type examination certificate BVS 11 ATEX E 013 X

Conformities

EMC Product family standard EN 61326
 Emitted interference EN 55011, CISPR11 CL. B
 ATEX EN 60079-0, EN 60079-11, EN 60079-26,
 EN 61241-11

Printed 11.07.2016. We reserve the right for technical changes



ADAMCZEWSKI
 Elektronische Messtechnik GmbH

Felix-Wankel-Str. 13
 Tel. +49 (0)7046-875
 vertrieb@ad-messtechnik.de

74374 Zaberfeld
 Fax +49 (0)7046-7678
 www.adamczewski.com



Supply Isolation Amplifier

AD-STVEX 710 GVD

Block and wiring diagram

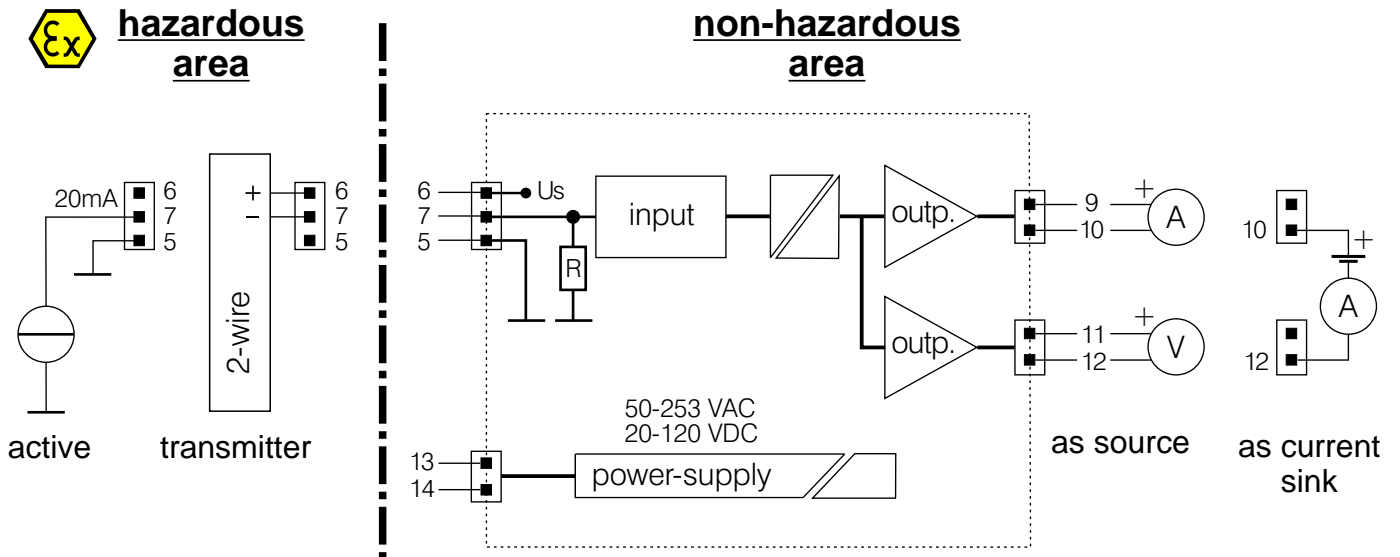

Terminal location

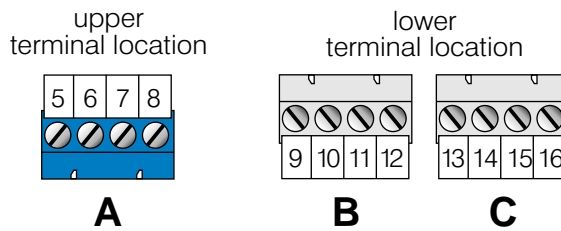

Note:
with Ex input terminal at the bottom use order option: S-388

Dimensions

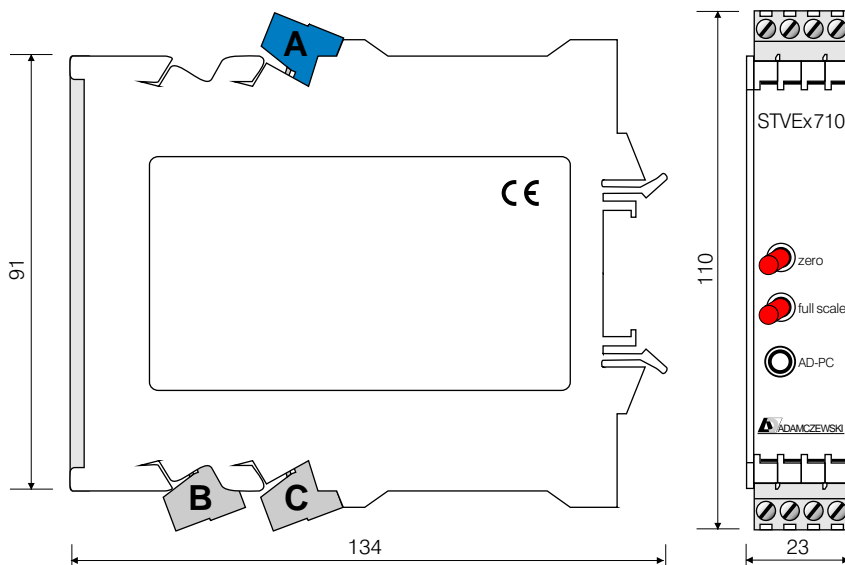

operating elements:

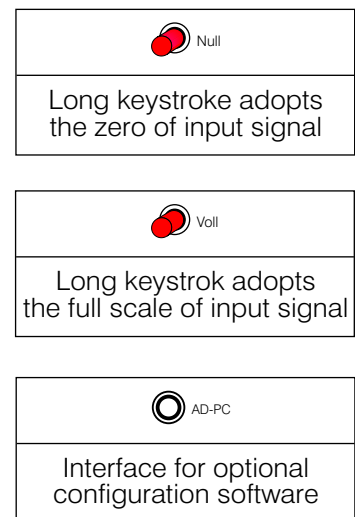

Printed 11.07.2016. We reserve the right for technical changes



ADAMCZEWSKI
Elektronische Messtechnik GmbH

Felix-Wankel-Str. 13
Tel. +49 (0)7046-875
vertrieb@ad-messtechnik.de

74374 Zaberfeld
Fax +49 (0)7046-7678
www.adamczewski.com