



POINT I/O Synchronous Serial Interface Absolute Encoder Module

Catalog number 1734-SSI, Series C

Table of Contents

Topic	Page
Important User Information	2
Environment and Enclosure	3
Preventing Electrostatic Discharge	3
North American Hazardous Location Approval	4
European Hazardous Location Approval	5
Additional Resources	6
About the Module	6
Install the Mounting Base	8
Install the Module	9
Install the Removable Terminal Block	10
Remove a Mounting Base	10
Wire the Modules	11
Communicate with Your Module	12
Interpret Status Indicators	14
Specifications	16

Important User Information

Solid-state equipment has operational characteristics differing from those of electromechanical equipment. Safety Guidelines for the Application, Installation and Maintenance of Solid State Controls (Publication [SGI-1.1](#) available from your local Rockwell Automation sales office or online at <http://www.rockwellautomation.com/literature/>) describes some important differences between solid-state equipment and hard-wired electromechanical devices. Because of this difference, and also because of the wide variety of uses for solid-state equipment, all persons responsible for applying this equipment must satisfy themselves that each intended application of this equipment is acceptable.

In no event will Rockwell Automation, Inc. be responsible or liable for indirect or consequential damages resulting from the use or application of this equipment.

The examples and diagrams in this manual are included solely for illustrative purposes. Because of the many variables and requirements associated with any particular installation, Rockwell Automation, Inc. cannot assume responsibility or liability for actual use based on the examples and diagrams.

No patent liability is assumed by Rockwell Automation, Inc. with respect to use of information, circuits, equipment, or software described in this manual.

Reproduction of the contents of this manual, in whole or in part, without written permission of Rockwell Automation, Inc., is prohibited.

Throughout this manual, when necessary, we use notes to make you aware of safety considerations.



WARNING: Identifies information about practices or circumstances that can cause an explosion in a hazardous environment, which may lead to personal injury or death, property damage, or economic loss.



ATTENTION: Identifies information about practices or circumstances that can lead to personal injury or death, property damage, or economic loss. Attentions help you identify a hazard, avoid a hazard and recognize the consequences.



SHOCK HAZARD: Labels may be on or inside the equipment (for example, drive or motor) to alert people that dangerous voltage may be present.



BURN HAZARD: Labels may be on or inside the equipment (for example, drive or motor) to alert people that surfaces may reach dangerous temperatures.

IMPORTANT

Identifies information that is critical for successful application and understanding of the product.

Environment and Enclosure



ATTENTION: This equipment is intended for use in a Pollution Degree 2 industrial environment, in overvoltage Category II applications (as defined in IEC 60664-1), at altitudes up to 2000 m (6562 ft) without derating.

This equipment is not intended for use in residential environments and may not provide adequate protection to radio communication services in such environments.

This equipment is supplied as open-type equipment. It must be mounted within an enclosure that is suitably designed for those specific environmental conditions that will be present and appropriately designed to prevent personal injury resulting from accessibility to live parts. The enclosure must have suitable flame-retardant properties to prevent or minimize the spread of flame, complying with a flame spread rating of 5VA or be approved for the application if nonmetallic. The interior of the enclosure must be accessible only by the use of a tool. Subsequent sections of this publication may contain additional information regarding specific enclosure type ratings that are required to comply with certain product safety certifications.

In addition to this publication, see:

- Industrial Automation Wiring and Grounding Guidelines, publication [1770-4.1](#), for additional installation requirements.
- NEMA Standard 250 and IEC 60529, as applicable, for explanations of the degrees of protection provided by enclosures.



Preventing Electrostatic Discharge



ATTENTION: This equipment is sensitive to electrostatic discharge, which can cause internal damage and affect normal operation. Follow these guidelines when you handle this equipment:

- Touch a grounded object to discharge potential static.
 - Wear an approved grounding wriststrap.
 - Do not touch connectors or pins on component boards.
 - Do not touch circuit components inside the equipment.
 - Use a static-safe workstation, if available.
 - Store the equipment in appropriate static-safe packaging when not in use.
-

North American Hazardous Location Approval

The following information applies when operating this equipment in hazardous locations:	Informations sur l'utilisation de cet équipement en environnements dangereux:
<p>Products marked "CL I, DIV 2, GPA, B, C, D" are suitable for use in Class I Division 2 Groups A, B, C, D, Hazardous Locations and nonhazardous locations only. Each product is supplied with markings on the rating nameplate indicating the hazardous location temperature code. When combining products within a system, the most adverse temperature code (lowest "T" number) may be used to help determine the overall temperature code of the system. Combinations of equipment in your system are subject to investigation by the local Authority Having Jurisdiction at the time of installation.</p>	<p>Les produits marqués "CL I, DIV 2, GPA, B, C, D" ne conviennent qu'à une utilisation en environnements de Classe I Division 2 Groupes A, B, C, D dangereux et non dangereux. Chaque produit est livré avec des marquages sur sa plaque d'identification qui indiquent le code de température pour les environnements dangereux. Lorsque plusieurs produits sont combinés dans un système, le code de température le plus défavorable (code de température le plus faible) peut être utilisé pour déterminer le code de température global du système. Les combinaisons d'équipements dans le système sont sujettes à inspection par les autorités locales qualifiées au moment de l'installation.</p>
<div style="display: flex; align-items: flex-start;">  <div> <p>EXPLOSION HAZARD</p> <ul style="list-style-type: none"> • Do not disconnect equipment unless power has been removed or the area is known to be nonhazardous. • Do not disconnect connections to this equipment unless power has been removed or the area is known to be nonhazardous. Secure any external connections that mate to this equipment by using screws, sliding latches, threaded connectors, or other means provided with this product. • Substitution of components may impair suitability for Class I, Division 2. • If this product contains batteries, they must only be changed in an area known to be nonhazardous. </div> </div>	<div style="display: flex; align-items: flex-start;">  <div> <p>RISQUE D'EXPLOSION</p> <ul style="list-style-type: none"> • Couper le courant ou s'assurer que l'environnement est classé non dangereux avant de débrancher l'équipement. • Couper le courant ou s'assurer que l'environnement est classé non dangereux avant de débrancher les connecteurs. Fixer tous les connecteurs externes reliés à cet équipement à l'aide de vis, loquets coulissants, connecteurs filetés ou autres moyens fournis avec ce produit. • La substitution de composants peut rendre cet équipement inadapté à une utilisation en environnement de Classe I, Division 2. • S'assurer que l'environnement est classé non dangereux avant de changer les piles. </div> </div>



ATTENTION: To comply with UL restrictions, the secondary circuit (backplane) must be powered from a source compliant with the following: Class 2 or Limited Voltage/Current.



ATTENTION: This product is grounded through the DIN rail to chassis ground. Use zinc plated yellow-chromate steel DIN rail to assure proper grounding. The use of other DIN rail materials (for example, aluminum or plastic) that can corrode, oxidize, or are poor conductors, can result in improper or intermittent grounding. Secure DIN rail to mounting surface approximately every 200 mm (7.8 in.) and use end-anchors appropriately.

European Hazardous Location Approval

European Zone 2 Certification. The following applies when the product bears the Ex Marking.

This equipment is intended for use in potentially explosive atmospheres as defined by European Union Directive 94/9/EC.

DEMCO certifies that this equipment has been found to comply with the Essential Health and Safety Requirements relating to the design and construction of Category 3 equipment intended for use in Zone 2 potentially explosive atmospheres, given in Annex II to this Directive.

Compliance with the Essential Health and Safety Requirements has been assured by compliance with EN 60079-15.



ATTENTION: This equipment is not resistant to sunlight or other sources of UV radiation.



WARNING: This equipment shall be mounted in an ATEX certified enclosure with a minimum ingress protection rating of at least IP54 (as defined in IEC60529) and used in an environment of not more than Pollution Degree 2 (as defined in IEC 60664-1) when applied in Zone 2 environments. The enclosure must utilize a tool removable cover or door.

WARNING: This equipment shall be used within its specified ratings defined by Rockwell Automation.

WARNING: Provision shall be made to prevent the rated voltage from being exceeded by transient disturbances of more than 140% of the rated voltage when applied in Zone 2 environments.

WARNING: Secure any external connections that mate to this equipment by using screws, sliding latches, threaded connectors, or other means provided with this product.

WARNING: Do not disconnect equipment unless power has been removed or the area is known to be nonhazardous.

Additional Resources

Refer to POINT™ I/O 5V and 24V Encoder/Counter Modules User Manual, publication [1734-UM006](#), as needed.

If you would like a manual, you can:

- download a free electronic version from the internet:
<http://www.rockwellautomation.com/literature/>
- purchase a printed manual by contacting your local Allen-Bradley distributor or Rockwell Automation representative.

About the Module

You can use this Series C module with DeviceNet and PROFIBUS adapters. If you are using RSLogix 5000 software, version 11 or higher, you can also use the Series C modules with ControlNet and Ethernet adapters.

This module collects serial data from industrial absolute-position encoding sensors that use standard SSI protocol. You insert the module into a POINT I/O terminal base that provides common power, communication, and wiring connections for the SSI sensors.

Use this diagram to identify the external features of the module.

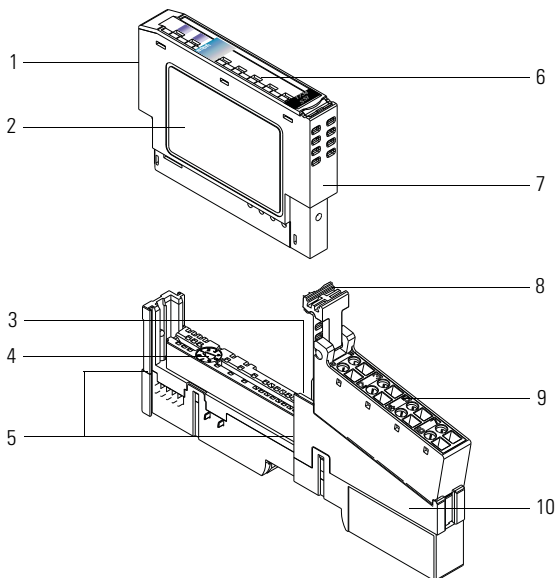
POINT I/O Synchronous Serial Interface Absolute Encoder Module

The wiring base assembly includes a terminal base, 1734-TB or 1734-TBS, which consists of a mounting base, 1734-MB, and removable terminal block, 1734-RT or 1734-RTS.

Module Description

	Description		Description
1	Module locking mechanism	6	Slide-in writable label
2	Module Wiring Diagram	7	Insertable I/O module
3	DIN rail locking screw (orange)	8	Removable terminal block handle
4	Mechanical keying (orange)	9	Removable terminal block
5	Interlocking side pieces	10	Mounting base

Install the Mounting Base

To install the mounting base on the DIN rail, proceed as follows:



ATTENTION: This product is grounded through the DIN rail to chassis ground. Use zinc plated yellow-chromate steel DIN rail to assure proper grounding. The use of other DIN rail materials (for example, aluminum or plastic) that can corrode, oxidize, or are poor conductors, can result in improper or intermittent grounding. Secure DIN rail to mounting surface approximately every 200 mm (7.8 in.) and use end-anchors appropriately.

1. Position the mounting base vertically above the installed units (adapter, power supply or existing module).
2. Slide the mounting base down allowing the interlocking side pieces to engage the adjacent module or adapter.
3. Press firmly to seat the mounting base on the DIN rail. The mounting base snaps into place.

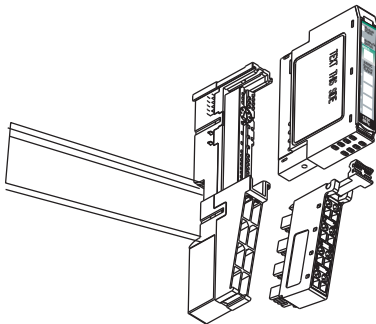

44013

4. To remove the mounting base from the DIN rail, remove the module and use a small bladed screwdriver to rotate the base locking screw to a vertical position. This releases the locking mechanism.
5. Then lift straight up to remove.

Install the Module

The module can be installed before or after base installation. Make sure that the mounting base is correctly keyed before installing the module into the mounting base. In addition, make sure the mounting base locking screw is positioned horizontal referenced to the base.

1. Using a bladed screwdriver, rotate the keyswitch on the mounting base clockwise until the number required for the type of module being installed aligns with the notch in the base.

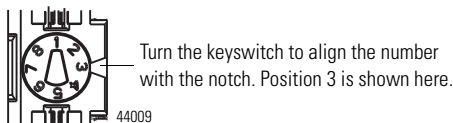

2. Make certain the DIN rail locking screw is in the horizontal position. You cannot insert the module if the locking mechanism is unlocked.

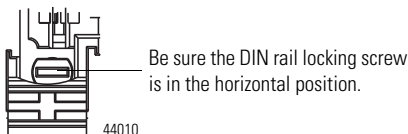

3. Insert the module straight down into the mounting base.

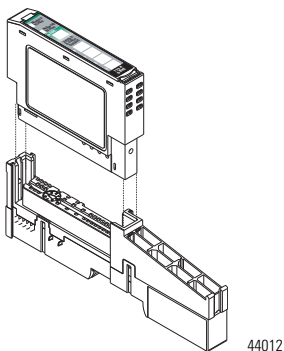

4. Press to secure. The module locks into place.

Install the Removable Terminal Block

A removable terminal block (RTB) is supplied with your wiring base assembly. To remove, pull up on the RTB handle. This allows the mounting base to be removed and replaced as necessary without removing any of the wiring.

To reinsert the removable terminal block, proceed as follows:

1. Insert the end opposite the handle into the base unit. This end has a curved section that engages with the wiring base.
2. Rotate the terminal block into the wiring base until it locks itself in place.
3. If an I/O module is installed, snap the RTB handle into place on the module.



WARNING: When you connect or disconnect the Removable Terminal Block (RTB) with field side power applied, an electrical arc can occur. This could cause an explosion in hazardous location installations. Be sure that power is removed or the area is nonhazardous before proceeding.

Remove a Mounting Base

To remove a mounting base, you must remove any installed module, and the module installed in the base to the right. Remove the removable terminal block, if wired.

1. Unlatch the RTB handle on the I/O module.
2. Pull on the RTB handle to remove the removable terminal block.
3. Press on the module lock on the top of the module.
4. Pull on the I/O module to remove from the base.
5. Repeat steps 1, 2, 3 and 4 for the module to the right.
6. Use a small bladed screwdriver to rotate the orange base locking screw to a vertical position. This releases the locking mechanism.
7. Lift straight up to remove.

Wire the Modules

To wire the modules, refer to the diagrams and tables.

POINT I/O Synchronous Serial Interface Absolute Encoder Module

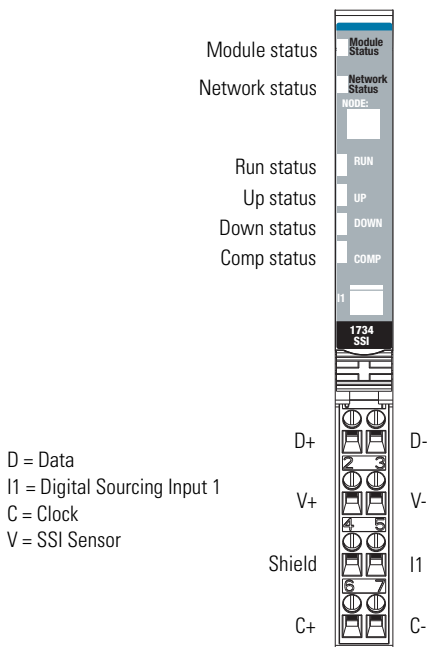

43123



WARNING: If you connect or disconnect wiring while the field-side power is on, an electrical arc can occur. This could cause an explosion in hazardous location installations. Be sure that power is removed or the area is nonhazardous before proceeding.

Wiring for 1734-SSI

0	D+	D-	1
2	V+	V-	3
4	Shield	I1	5
6	C+	C-	7

D = Data, I1 = Digital, Sourcing
Input 1, C = Clock, V = SSI Sensor

Termination	Definition ⁽¹⁾
0	D+
1	D-
2	V+
3	V-
4	Shield
5	I1
6	C+
7	C-

⁽¹⁾ D and C terminations are RS422-type differential pairs.

Communicate with Your Module

The module transmits SSI sensor data over the DeviceNet network. You exchange data with the master through a polled, cyclic, or change-of-state connection.

The module does not support Bit-Strobe Command Response Messaging and the Unconnected Message Manager (UCMM). If you are not familiar with these terms, see the DeviceNet Specification for definitions at <http://www.odva.org>.

The module produces and consumes data as follows:

I/O Connection Type	Consumes	Produces
Polled	2 bytes	10 bytes
Cyclic	2 bytes	10 bytes
Change-of-state	2 bytes	10 bytes

Consume and Produce Bit/Byte Definitions

Byte	Bit	
Produce 0	0...7	Low byte of present low SSI word. Bit 0 is the least significant bit of the entire present SSI word.
Produce 1	0...7	High byte of present low SSI word.
Produce 2	0...7	Low byte of present high SSI word.
Produce 3	0...7	High byte of present high SSI word. Bit 7 is the most significant bit of the entire present SSI word.
Produce 4	0...7	Low byte of stored low SSI word. Bit 0 is the least significant bit of the entire stored SSI word.
Produce 5	0...7	High byte of stored low SSI word.
Produce 6	0...7	Low byte of stored high SSI word.
Produce 7	0...7	High byte of stored high SSI word. Bit 7 is the most significant bit of the entire stored SSI word.

Consume and Produce Bit/Byte Definitions

Byte	Bit								Description
Produce 8	7	6	5	4	3	2	1	0	Status byte 0 ⁽¹⁾
	C2ST	C1ST	C2R	C1R	INC	DEC	RUN	I1	
Produce 9	7	6	5	4	3	2	1	0	Status byte 1 ⁽²⁾
	RES	RES	RES	LHON	IDF ²	CCE	CCF	SPF	

⁽¹⁾ For detailed descriptions of these bits, see 1734-SSI User Manual, publication [1734-UM009](#).

⁽²⁾ Monitor IDF to determine the validity of the produced data. If IDF=1, the SSI data is false.

Consume and Produce Bit/Byte Definitions

Byte	Bit								Description
Consume 0	7	6	5	4	3	2	1	0	Master ACK byte ⁽¹⁾
	RES	RES	RES	SCMP2	SCMP1	CC2	CC1	LACK	
Consume 1	7	6	5	4	3	2	1	0	CONS1
	RES	RES	RES	RES	RES	RES	RES	RES	

⁽¹⁾ The master must provide the master ACK byte to receive the polled produced bytes 0...9.

Interpret Status Indicators

Refer to the following diagram and tables for information on how to interpret the status indicators.

POINT I/O Synchronous Serial Interface Absolute Encoder Module

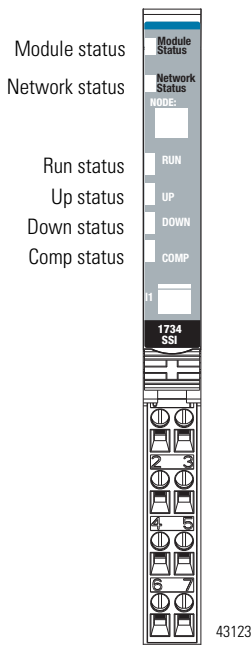

Indicator Status for Modules

	Status	Description
Module status	Off	No power applied to device.
	Green	Device operating normally.
	Flashing green	Device needs commissioning due to missing, incomplete, or incorrect configuration.
	Flashing red	Recoverable fault.
	Red	Unrecoverable fault – may require device replacement.
	Flashing red/green	Device is in self-test mode.
Network status	Off	Device is not online: - Device has not completed dup_MAC-id test. - Device not powered – check module status indicator.
	Flashing green	Device is online but has no connections in the established state.
	Green	Device is online and has connections in the established state.
	Flashing red	One or more I/O connections are in timed-out state.
	Red	Critical link failure – failed communication device. Device detected error that prevents it from communicating on the network.
	Flashing red/green	Communication faulted device – the device has detected a network access error and is in communication faulted state. Device has received and accepted an Identity Communication Faulted Request – long protocol message.
Run status	Off	Module is commanded to stop retrieving SSI data.
	Green	Module is commanded to retrieve SSI data.
Up status	Off	SSI data not increasing, or no SSI data is being received.
	Green	SSI data is increasing.
Down status	Off	SSI data not decreasing, or no SSI data is being received.
	Green	SSI data is decreasing.
Comp status	Off	Comparator function is not in use, or comparator value not attained.
	Green	Comparator value attained.
I1 status	Off	Latching input I1 is OFF.
	Green	Latching input I1 is ON.

Specifications

POINT I/O Synchronous Serial Interface Absolute Encoder Module – 1734-SSI, Series C

Attribute	Value																				
Number of SSI channels	1																				
Encoder type	Any absolute encoder supporting standard SSI protocol including linear, rotary, and optical distance measuring devices Most-Significant Bit Aligned data format Physical interface for clock and data signals is RS-422																				
SSI data rate	125 kHz, 250 kHz, 500 kHz, 1 MHz, 2 MHz (software selectable)																				
SSI bits per word	2...31 (software selectable)																				
SSI word delay time ⁽¹⁾	16 μ s...65535 μ s (software selectable)																				
SSI word length	4 bytes (32 bits)																				
SSI features	Gray or binary code capable with gray to binary conversion, increasing or decreasing SSI count indication, 2 SSI word comparator values, SSI word latching with I1 input																				
SSI position forming time ⁽²⁾	≥ 0.5 ms																				
SSI cable type	UL CM/AWM 2464/CSA Type CMG FT4 or similar cable utilizing shielded twisted pairs for D+/- and C+/- connections. See sensor manufacturer for actual cable required for the SSI sensor under use. I1 input can be separate from SSI cable.																				
SSI cable length	Depends on desired SSI data rate: 125 kHz – 320 m (1050 ft) 250 kHz – 160 m (525 ft) 500 kHz – 60 m (195 ft) 1 MHz – 20 m (65 ft) 2 MHz – 8 m (25 ft)																				
SSI sensor power	450 mA, 10...28.8V DC																				
SSI clock drive current (Out of C+/- terminals), max	125 mA																				
Input I1	IEC Type 3 voltage and current characteristics, sourcing type																				
	<table border="1"> <thead> <tr> <th></th> <th>Minimum</th> <th>Nominal</th> <th>Maximum</th> </tr> </thead> <tbody> <tr> <td>ON-state voltage</td> <td>0V DC</td> <td>-</td> <td>FPV* -10</td> </tr> <tr> <td>ON-state current</td> <td>2 mA</td> <td>4 mA (FPV=24V DC)</td> <td>5 mA</td> </tr> <tr> <td>OFF-state voltage</td> <td>FPV-5</td> <td>-</td> <td>FPV</td> </tr> <tr> <td>OFF-state current</td> <td>1.2 mA</td> <td>-</td> <td>-</td> </tr> </tbody> </table>		Minimum	Nominal	Maximum	ON-state voltage	0V DC	-	FPV* -10	ON-state current	2 mA	4 mA (FPV=24V DC)	5 mA	OFF-state voltage	FPV-5	-	FPV	OFF-state current	1.2 mA	-	-
	Minimum	Nominal	Maximum																		
ON-state voltage	0V DC	-	FPV* -10																		
ON-state current	2 mA	4 mA (FPV=24V DC)	5 mA																		
OFF-state voltage	FPV-5	-	FPV																		
OFF-state current	1.2 mA	-	-																		

POINT I/O Synchronous Serial Interface Absolute Encoder Module – 1734-SSI, Series C

Attribute	Value
Input impedance	- 3.6 k Ω 4.7 k Ω
Input filter time	- 0.5 ms -
*FPV = Field power supply voltage	

- (1) Time between successive SSI words (Tp). Also called Dwell Time.
- (2) Roughly corresponds to the maximum time the SSI sensor can be expected to output a particular position value while in motion. To use the 1734-SSI module with sensors that have faster position forming times, change the SSI Word Filter Control parameter from its default value of 5 (max). Changing this parameter from its default value sacrifices electrical noise environment performance for sensor data conversion speed.

General Specifications

Attribute	Value
Terminal base screw torque, max	0.6 Nm (7 lb-in.)
LED indicators	All powered from the logic side
Module location	1734-TB, 1734-TBS wiring base assembly
POINTBus current	110 mA @ 5V DC
Power dissipation	0.94 W
Isolation voltage	50V (continuous), Basic Insulation Type Tested @ 1250V AC for 60 s, field to system
Field power bus supply voltage, min	10V DC @ 450 mA
Field power bus supply voltage, nom	24V DC @ 450 mA
Field power bus supply voltage, max	28.8V DC @ 450 mA
Dimensions, HxWxD	56.0 x 12.0 x 75.5 mm (2.21 x 0.47 x 2.97 in.)
Conductor category ⁽¹⁾	1 – on signal ports
Wire size	0.34...2.1 mm ² (22...14 AWG) solid or stranded copper wire rated @ 75 °C (167 °F), or greater, 1.2 mm (3/64 in.) insulation max
Wire type	Copper Shielded on encoder port
Weight	0.032 kg (0.07 lb)
Keyswitch position	2

General Specifications

Attribute	Value
Enclosure type rating	None (open-style)
North American temp code	T4A
IEC temperature code	T4

- (1) Use this conductor category information for planning conductor routing as described in Industrial Automation Wiring and Grounding Guidelines, publication [1770-4.1](#).

Environmental Specifications

Attribute	Value
Temperature, operating	IEC 60068-2-1 (Test Ad, Operating Cold), IEC 60068-2-2 (Test Bd, Operating Dry Heat), IEC 60068-2-14 (Test Nb, Operating Thermal Shock): -20...55 °C (-4...131 °F)
Temperature, surrounding air, max.	55 °C (131 °F)
Temperature, nonoperating	IEC 60068-2-1 (Test Ab, Unpackaged Nonoperating Cold), IEC 60068-2-2 (Test Bb, Unpackaged Nonoperating Dry Heat), IEC 60068-2-14 (Test Na, Unpackaged Nonoperating Thermal Shock): -40...85 °C (-40...185 °F)
Relative humidity	IEC 60068-2-30 (Test Db, Unpackaged Damp Heat): 5...95% noncondensing
Vibration	IEC 60068-2-6 (Test Fc, Operating): 5 g @ 10...500 Hz
Shock, operating	IEC 60068-2-27 (Test Ea, Unpackaged Shock): 30 g
Shock, nonoperating	IEC 60068-2-27 (Test Ea, Unpackaged Shock): 50 g
Emissions	CISPR 11 (IEC 61000-6-4): Class A
ESD immunity	IEC 61000-4-2: 6 kV contact discharges 8 kV air discharges
Radiated RF immunity	IEC 61000-4-3: 10V/m with 1 kHz sine-wave 80% AM from 80...2000 MHz 10V/m with 200 Hz 50% pulse 100% AM @ 900 MHz 10V/m 200 Hz 50% pulse 100% AM @ 1890 MHz 10V/m with 1 kHz sine-wave 80% AM from 2000...2700 MHz

Environmental Specifications

Attribute	Value
EFT/B immunity	IEC 61000-4-4: ±3 kV @ 5 kHz on signal ports
Surge transient immunity	IEC 61000-4-5: ±1 kV line-line (DM) and ±2 kV line-earth (CM) on signal ports ±2 kV line-earth (CM) on shielded ports
Conducted RF immunity	IEC61000-4-6: 10 V rms with 1 kHz sine-wave 80% AM from 150 kHz...80 MHz

Certifications

Certification (when product is marked) ⁽¹⁾	Value
c-UL-us	UL Listed Industrial Control Equipment, certified for US and Canada. See UL File E65584. UL Listed for Class I, Division 2 Group A,B,C,D Hazardous Locations, certified for U.S. and Canada. See UL File E194810.
CE	European Union 2004/108/EC EMC Directive, compliant with: EN 61326-1; Meas./Control/Lab., Industrial Requirements EN 61000-6-2; Industrial Immunity EN 61000-6-4; Industrial Emissions EN 61131-2; Programmable Controllers (Clause 8, Zone A & B)
C-Tick	Australian Radiocommunications Act, compliant with: AS/NZS CISPR 11; Industrial Emissions
Ex	European Union 94/9/EC ATEX Directive, compliant with: EN 60079-15; Potentially Explosive Atmospheres, Protection "n" EN 60079-0; General Requirements II 3 G Ex nA IIC T4 Gc
KC	Korean Registration of Broadcasting and Communications Equipment, compliant with: Article 58-2 of Radio Waves Act, Clause 3

⁽¹⁾ See the Product Certification link at <http://www.rockwellautomation.com/products/certification/> for Declaration of Conformity, Certificates, and other certification details.

Rockwell Automation Support

Rockwell Automation provides technical information on the Web to assist you in using its products. At <http://www.rockwellautomation.com/support/>, you can find technical manuals, a knowledge base of FAQs, technical and application notes, sample code and links to software service packs, and a MySupport feature that you can customize to make the best use of these tools.

For an additional level of technical phone support for installation, configuration and troubleshooting, we offer TechConnect support programs. For more information, contact your local distributor or Rockwell Automation representative, or visit <http://www.rockwellautomation.com/support/>.

Installation Assistance

If you experience a problem within the first 24 hours of installation, please review the information that's contained in this manual. You can also contact a special Customer Support number for initial help in getting your product up and running.

United States or Canada	1.440.646.3434
Outside United States or Canada	Use the Worldwide Locator at http://www.rockwellautomation.com/support/americas/phone_en.html , or contact your local Rockwell Automation representative.

New Product Satisfaction Return

Rockwell Automation tests all of its products to ensure that they are fully operational when shipped from the manufacturing facility. However, if your product is not functioning and needs to be returned, follow these procedures.

United States	Contact your distributor. You must provide a Customer Support case number (call the phone number above to obtain one) to your distributor to complete the return process.
Outside United States	Please contact your local Rockwell Automation representative for the return procedure.

Documentation Feedback

Your comments will help us serve your documentation needs better. If you have any suggestions on how to improve this document, complete this form, publication [RA-DU002](#), available at <http://www.rockwellautomation.com/literature/>.

Allen-Bradley, Rockwell Automation, ArmorBlock, and TechConnect are trademarks of Rockwell Automation, Inc.

Trademarks not belonging to Rockwell Automation are property of their respective companies.

Rockwell Otomasyon Ticaret A.Ş., Kar Plaza İş Merkezi E Blok Kat:6 34752 İçerenköy, İstanbul, Tel: +90 (216) 5698400

www.rockwellautomation.com

Power, Control and Information Solutions Headquarters

Americas: Rockwell Automation, 1201 South Second Street, Milwaukee, WI 53204-2496 USA, Tel: (1) 414.382.2000, Fax: (1) 414.382.4444
Europe/Middle East/Africa: Rockwell Automation, Voortaan/Bolevard du Souverain 36, 1170 Brussels, Belgium, Tel: (32) 2 663 0600, Fax: (32) 2 663 0640
Asia Pacific: Rockwell Automation, Level 14, Core F, Cyberport 3, 100 Cyberport Road, Hong Kong, Tel: (852) 2887 4788, Fax: (852) 2508 1846

Publication 1734-IN581D-EN-E - January 2014

Supersedes Publication 1734-IN581C-EN-E - June 2005

Copyright © 2014 Rockwell Automation, Inc. All rights reserved.