

Industrial Integrated Display Computers

Catalog Numbers 6181F, 6181P

Topic	Page
Important User Information	2
Precautions	3
Computer Options	4
Operating Systems	5
Parts List	6
Mounting Clearances	8
Install the Computer	13
Mount the Display Computer in a Panel	14
Connect Peripherals	15
Connect Peripherals	15
Apply Power	17
Connect to a Network	20
Real Time Clock (RTC) Battery	20
Ship or Transport the Computer	21
Specifications	22
Additional Resources	24

Important User Information

Solid-state equipment has operational characteristics differing from those of electromechanical equipment. Safety Guidelines for the Application, Installation and Maintenance of Solid State Controls (publication [SGL-1.1](#) available from your local Rockwell Automation sales office or online at <http://www.rockwellautomation.com/literature/>) describes some important differences between solid-state equipment and hard-wired electromechanical devices. Because of this difference, and also because of the wide variety of uses for solid-state equipment, all persons responsible for applying this equipment must satisfy themselves that each intended application of this equipment is acceptable.





In no event will Rockwell Automation, Inc. be responsible or liable for indirect or consequential damages resulting from the use or application of this equipment.

The examples and diagrams in this manual are included solely for illustrative purposes. Because of the many variables and requirements associated with any particular installation, Rockwell Automation, Inc. cannot assume responsibility or liability for actual use based on the examples and diagrams.

No patent liability is assumed by Rockwell Automation, Inc. with respect to use of information, circuits, equipment, or software described in this manual.

Reproduction of the contents of this manual, in whole or in part, without written permission of Rockwell Automation, Inc., is prohibited.

Throughout this manual, when necessary, we use notes to make you aware of safety considerations.

	WARNING: Identifies information about practices or circumstances that can cause an explosion in a hazardous environment, which may lead to personal injury or death, property damage, or economic loss.
	ATTENTION: Identifies information about practices or circumstances that can lead to personal injury or death, property damage, or economic loss. Attentions help you identify a hazard, avoid a hazard and recognize the consequences.
	SHOCK HAZARD: Labels may be on or inside the equipment, for example, a drive or motor, to alert people that dangerous voltage may be present.
	BURN HAZARD: Labels may be on or inside the equipment, for example, a drive or motor, to alert people that surfaces may reach dangerous temperatures.
IMPORTANT	Identifies information that is critical for successful application and understanding of the product.

Precautions

Read and follow these precautions for use.

Environment and Enclosure Information



ATTENTION: This equipment is intended for use in a Pollution Degree 2 industrial environment, in overvoltage Category II applications (as defined in IEC publication 60664-1), at altitudes up to 2000 m (6561 ft) without derating.

This equipment is considered Group 1, Class A industrial equipment according to IEC/CISPR 11. Without appropriate precautions, there may be difficulties with electromagnetic compatibility in residential and other environments due to conducted and radiated disturbances.

UL listed equipment need not be mounted inside another enclosure if NEMA Type and IEC ratings are not required, but the mounting method must limit the tilt of the computer to no more than 60° from vertical. An example is a tabletop stand. The mounting means must be firmly attached to the supporting surface using screws, bolts, or clamps so the computer cannot tip. These computers ship with a gasketed bezel to meet specified NEMA and IEC ratings only when mounted in a panel or enclosure with an equivalent rating. Subsequent sections of this publication may contain additional information regarding specific enclosure type ratings that are required to comply with certain product safety certifications.

In addition to this publication, see the following:

- Industrial Automation Wiring and Grounding Guidelines, publication [1770-4.1](#), for additional installation requirements
- NEMA Standard 250 and IEC 60529, as applicable, for explanations of the degrees of protection provided by enclosures

European Union Directive Compliance

This computer meets the European Union Directive requirements when installed within the European Union or EEA regions and have the CE mark. A copy of the Declaration of Conformity (DoC) is available at

<http://www.rockwellautomation.com/rockwellautomation/certification/overview.page>.



ATTENTION: This equipment is intended to operate in an industrial or control room environment, which uses some form of power isolation from the public low-voltage mains. Some computer configurations may not comply with the EN 61000-3-2 Harmonic Emissions standard as specified by the EMC Directive of the European Union. Obtain permission from the local power authority before connecting any computer configuration that draws more than 75 W of AC power directly from the public mains.

To comply with EN 55024, the Ethernet port LAN cable must be less than 30 m (98.42 ft). All other I/O cables must be less than 3 m (9.84 ft) and only used indoors; these cables must not exit the building at any point.

Computer Options

Available Options

Cat. No.	Model	Series	Display Size (in.)	Storage ⁽³⁾	Touchscreen	Windows OS	Package				
6181F-2PW7	NDM	E	N/A	SSD	N/A	7 Pro 32 bit	Performance				
6181F-2PW7DC ⁽¹⁾											
6181P-2PW7											
6181P-2PW7DC ⁽¹⁾				HDD							
6181P-2PXP											
6181P-2PXPDC ⁽¹⁾						XP Pro SP3					
6181F-12TPW7	1200P	E	12.1	SSD	Yes	7 Pro 32 bit	Performance				
6181F-12TPW7DC ⁽¹⁾											
6181F-12TPWE						WES 2009					
6181F-12TPWEDC ⁽¹⁾											
6181F-12TPXP						XP Pro SP3					
6181F-12TPXPDC ⁽¹⁾											
6181F-12TSXP				HDD	No	XP Pro SP3	Standard				
6181F-12TSWE								WES 2009			
6181P-12NSXP								Yes	7 Pro 32 bit	Performance	
6181P-12NXP											
6181P-12TPW7											
6181P-12TPW7DC ⁽¹⁾											
6181P-12TPXP				XP Pro SP3							
6181P-12TPXPDC ⁽¹⁾											
6181P-12TSXP				HDD	No	XP Pro SP3	Standard				
6181F-15TPW7								1500P	E	15	SSD
6181F-15TPW7DC ⁽¹⁾											
6181F-15TPW7SS ⁽²⁾											
6181F-15TPWE	WES 2009										
6181F-15TPWEDC ⁽¹⁾											
6181F-15TPWESS ⁽²⁾											
6181F-15TPXP	XP Pro SP3										
6181F-15TPXPDC ⁽¹⁾											
6181F-15TPXPSS ⁽²⁾											
6181F-15TSXP		HDD	No	XP Pro SP3	Standard						
6181F-15TSWE						WES 2009					
6181P-15NSXP						Yes	7 Pro 32 bit				Performance
6181P-15NXP											
6181P-15TPW7											
6181P-15TPW7DC ⁽¹⁾											
6181P-15TPW7SS ⁽²⁾											

Available Options (cont.)

Cat. No.	Model	Series	Display Size (in.)	Storage ⁽³⁾	Touchscreen	Windows OS	Package				
6181P-15TPXP	1500P	E	15	HDD	Yes	XP Pro SP3	Performance				
6181P-15TPXDC ⁽¹⁾											
6181P-15TPXPSS ⁽²⁾											
6181P-15TSXP							Standard				
6181F-17TPW7	1700P	E	17	SSD	Yes	7 Pro 32 bit	Performance				
6181F-17TPW7DC ⁽¹⁾											
6181F-17TPW7SS ⁽²⁾											
6181F-17TPWE								WES 2009			
6181F-17TPWEDC ⁽¹⁾											
6181F-17TPWESS ⁽²⁾											
6181F-17TPXP						XP Pro SP3					
6181F-17TPXPSS ⁽²⁾											
6181F-17TPXDC ⁽¹⁾											
6181F-17TSXP				Standard							
6181F-17TSWE				WES 2009							
6181P-17NSXP				HDD					XP Pro SP3	Performance	
6181P-17NPXP											
6181P-17TPW7											7 Pro 32 bit
6181P-17TPW7DC ⁽¹⁾											
6181P-17TPW7SS ⁽²⁾											
6181P-17TPXP	XP Pro SP3										
6181P-17TPXDC ⁽¹⁾											
6181P-17TPXPSS ⁽²⁾											
6181P-17TSXP		Standard									

(1) Models with a catalog number ending in DC operate from DC power.

(2) Models with a catalog number ending in SS have a stainless steel bezel.

(3) HDD signifies hard-disk drive and SSD signifies solid-state drive.

Operating Systems

Computers are shipped with one of these Microsoft-licensed operating systems:

- Windows 7 Professional (32 bit)
- Windows XP Professional, Service Pack 3
- Windows Embedded Standard (WES) 2009

No Windows XP operating system updates have been applied to the factory image beyond the service packs. All available WES 2009 operating system updates have been applied as of September 2009.

For computers with the Windows XP operating system, the I386 source directory for Microsoft Windows is on the system drive of your computer off the root directory, C:\I386. This allows for easy removal and addition of Windows components.

Computers with rotating hard-disk drives include a recovery partition on the system drive containing the original factory image. You can use the supplied Computer System Cloning CD to restore the operating system from the recovery partition and create a new recovery image. Refer to the Cloning Utility Technical Data, publication [6000-TD002](#), for instructions.

Computers with the WES 2009 operating system include a utility for configuring the Enhanced Write Filter (EWF) and Hibernate Once, Restore Many (HORM) features. Refer to the EWF/HORM Configuration Utility Technical Data, publication [6000-TD003](#), for instructions.

To obtain the original factory image on bootable external-recovery media, contact your local technical support center.

Parts List

Your computer is shipped with the following items:

- Panel mounting clips (display models only)
- Power cord (for AC power models)
- Ground bus strip, pre-installed (for DC power models)
- Panel cutout template
- Installation instructions
- Production test report
- System CDs
 - Accessory CD with Cloning Utility (red)
 - DVD burning software (Windows XP performance models only)

Required Tools

These tools are required for computer installation:

- Panel cutout tools (panel mount only)
- #2 Phillips screwdriver
- Antistatic wrist strap (recommended)

Installation Guidelines

Follow these guidelines to make sure your computer provides safe and reliable service:

- The installation site must have sufficient power.



ATTENTION: To maintain an electrically safe installation, the AC powered computers must be plugged into a grounded outlet.

-
- The enclosure must allow sufficient space around air inlets and outlets to provide the circulation necessary for cooling. Never allow air passages to become obstructed.
 - The ambient air temperature must not exceed the maximum operating temperature. Consider heat produced by other devices in the enclosure. You can use a user-supplied fan, heat exchanger, or air conditioner to meet this condition.

TIP Hot air rises. The temperature at the top of the enclosure is often higher than the temperature in other parts of the enclosure, especially if air is not circulating.

IMPORTANT The computer can operate at a range of extremes. However, the life span of any electronic device is shortened if you continuously operate the computer at its highest rated temperature.

- The humidity of the ambient air must not exceed specified limits. In very dry environments, static charges build up readily. Proper grounding of the equipment helps to reduce static discharges, which can cause shocks and damage electronic components.
- The enclosure or cover must remain in place at all times during operation. The cover provides protection against high voltages inside the computer and inhibits radio-frequency emissions that can interfere with other equipment.

- When mounted, the computer cannot be tilted more than 60° from vertical.

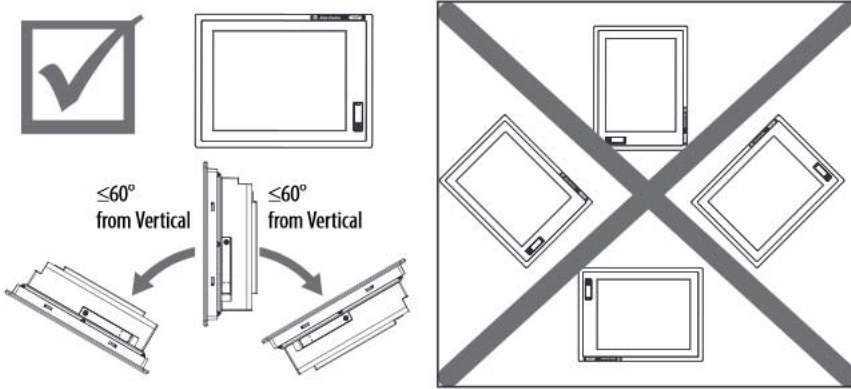

Mounting Clearances

IMPORTANT Because of self-heating, do not operate the computer in an enclosure using minimum clearances unless adequate ventilation or other cooling methods are used to lower the temperature within the enclosure.

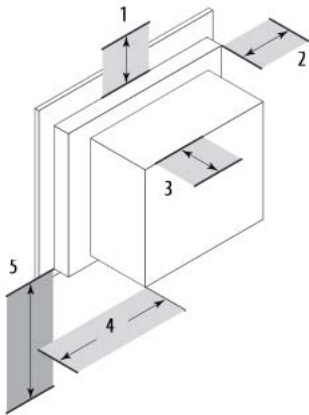

Item	Description	Value
1	Top	50 mm (2 in.)
2	Left (for airflow)	50 mm (2 in.)
3	Back	50 mm (2 in.)
4	Right (for airflow and drive access)	127 mm (5 in.)
5	Bottom (for I/O port access and ventilation)	102 mm (4 in.)

Right and left are based on facing the front of the computer.

Computer Dimensions

Dimensions for the computers are in mm (in).

Non-display Computers

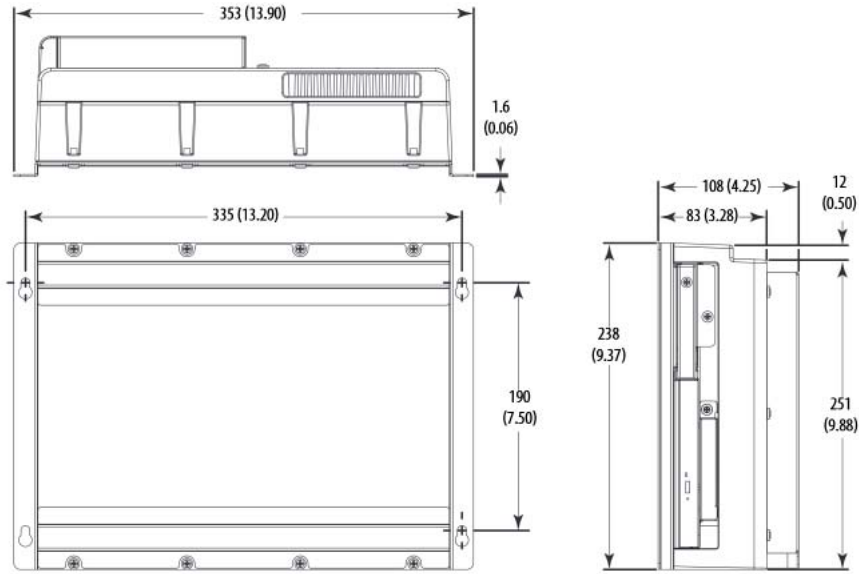

1200P Integrated Display Computer - Performance

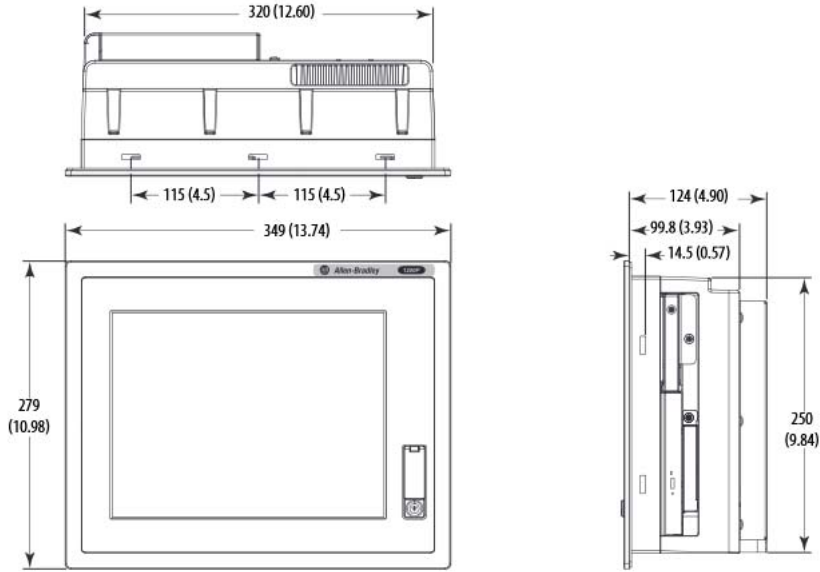

1200P Integrated Display Computer - Standard

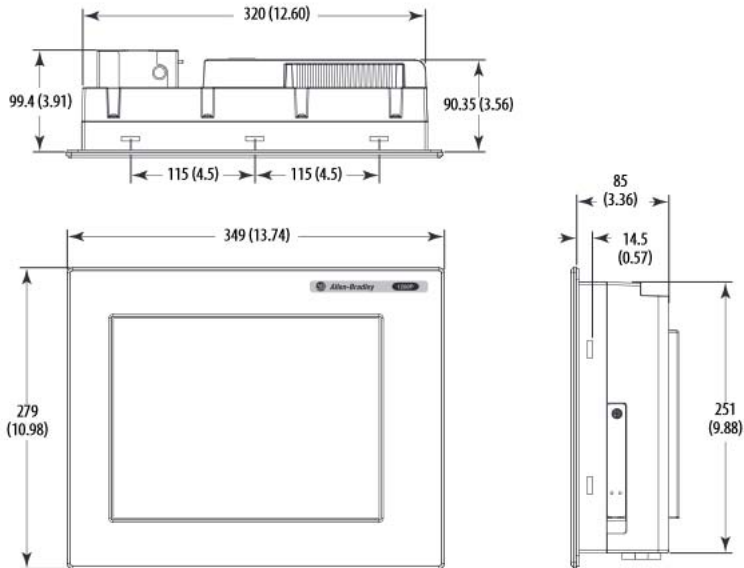

1500P Integrated Display Computer - Performance

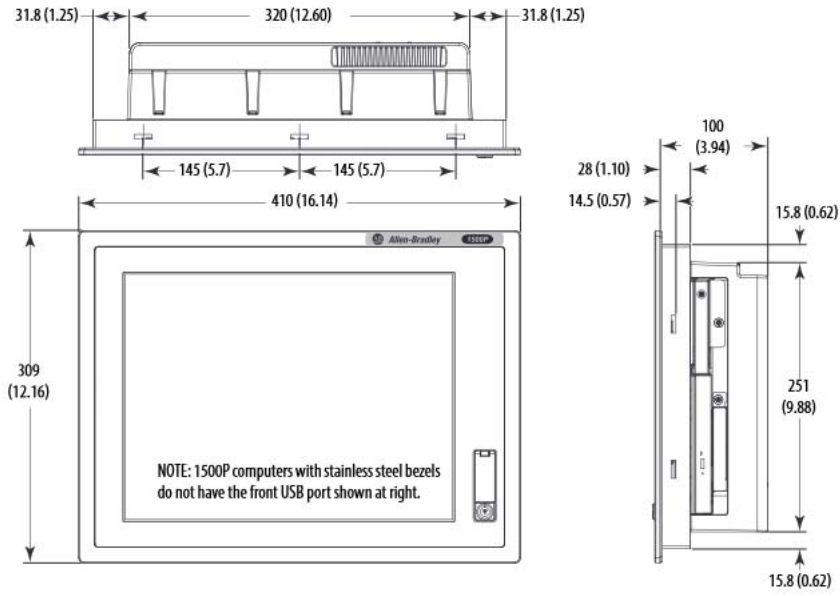

1500P Integrated Display Computer - Standard

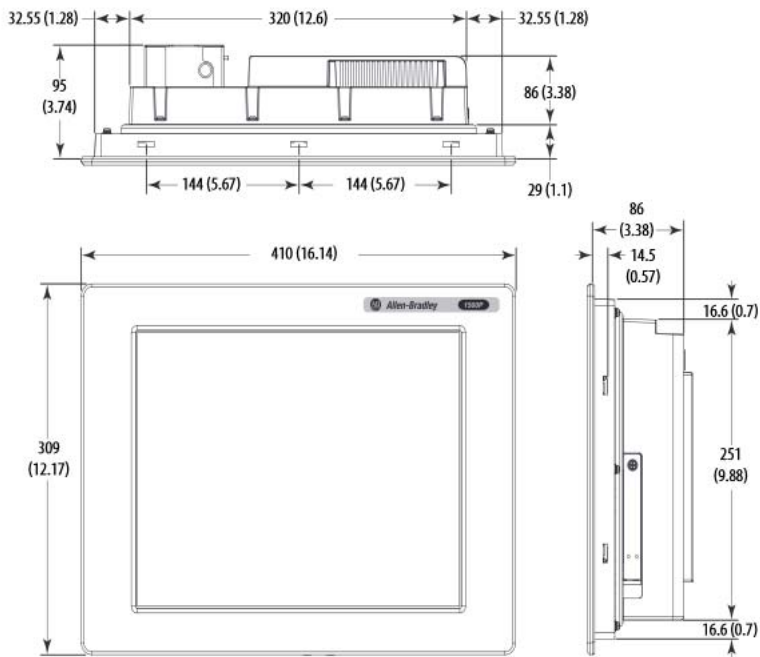

1700P Integrated Display Computers - Performance

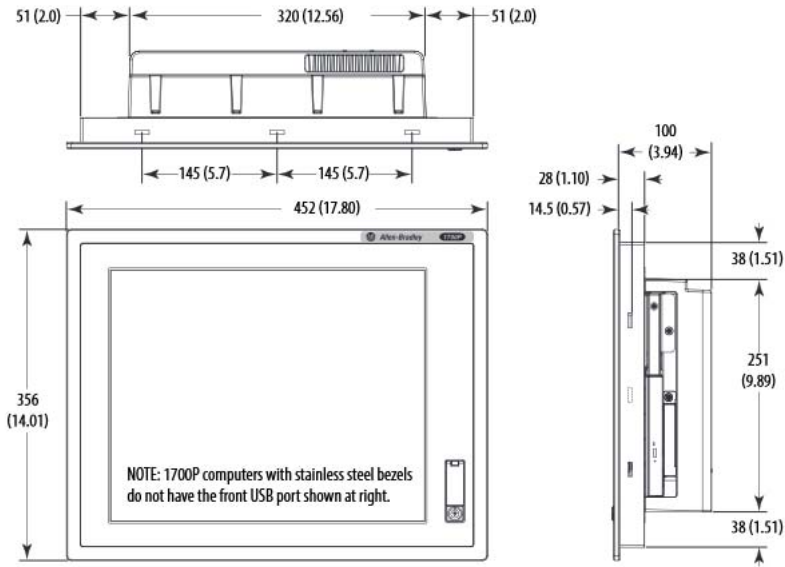

1700P Integrated Display Computer - Standard

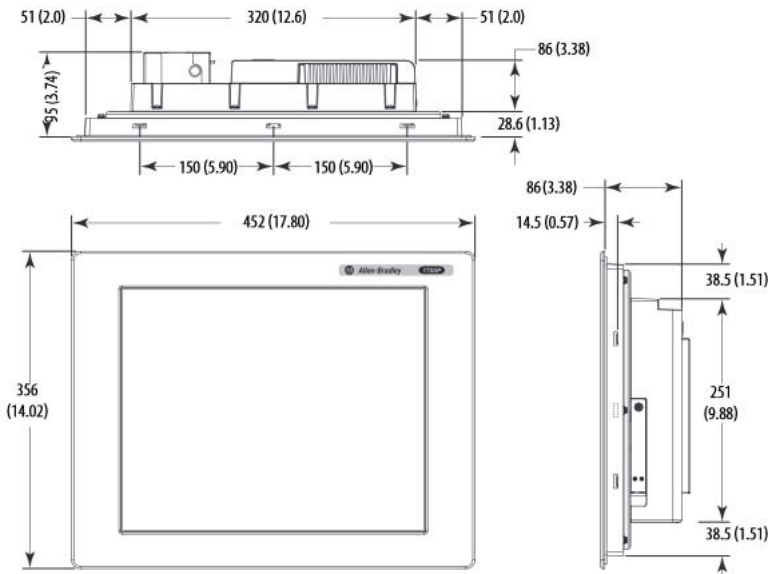

Install the Computer

The computers support the following mounting options:

- Panel mount
- Wall mount (for non-display computers)

Panel Mounting Guidelines

Observe these guidelines when installing the computer in a panel:

- Remove all electrical power from the panel before making the cutout.
- Confirm that there is adequate space behind the panel. For specific information, refer to [Mounting Clearances on page 8](#).
- Cut supporting panels to specifications before installation. Take precautions so metal cuttings do not enter components already installed in panel.

Supporting panels must be at least 14 gauge for proper sealing against water and dust, and to provide proper support. The mounting hardware supplied accommodates panel thickness 1.5...5.5 mm (0.06...0.25 in.).

- Make sure the area around the panel cutout is clear.



ATTENTION: Failure to follow these guidelines can result in personal injury or damage to the panel components.

Panel Cutout Dimensions

The computers must be mounted to meet the panel cutout dimensions specified below.

Included with the computer is 6181P and 6181X Industrial Computers Cutout Template, publication [6181P-DS002](#), with a cutout template for each display computer model.

Computer Model	Cutout Dimensions (H x W), approx
1200P	254.0 x 324.0 mm (10.0 x 12.76 in.)
1500P	285.0 x 386.6 mm (11.24 x 15.22 in.)
1700P	329.5 x 424.0 mm (12.97 x 16.69 in.)

Mount the Display Computer in a Panel

Mounting clips secure the display computer to the panel. The number of clips varies by model.

Computer Model	Number of Clips
All display models with aluminum bezel and 1500P display with stainless steel bezel	10
1700P display with stainless steel bezel	12

Cat. No.	Description
6189V-MCLPS3	Replacement mounting clips (14)

Follow these steps to mount the computer in a panel.

1. Remove power from the panel.
2. Cut an opening in the panel by using the appropriate panel cutout dimensions.
3. Attach cables to the computer before installation if rear access to the computer is limited after installation. See [Connect Peripherals on page 15](#) for where to attach cables.
4. Place the computer in the panel cutout.
5. Slide the mounting clips into the holes on the top, bottom, and sides of the computer.
6. Hand-tighten the mounting clips around the bezel by following the tightening sequence shown below.
7. Tighten the mounting clips to a torque of 1.35 N•m (12 lb•in) by following the torquing sequence shown below, making sure to not overtighten.
8. Repeat the torque sequence at least three times until the clips are properly torqued, making sure the gasket is compressed uniformly against the panel.



ATTENTION: Tighten the mounting clips to the specified torque to provide a proper seal and prevent damage to the computer. Rockwell Automation assumes no responsibility for water or chemical damage to the computer or other equipment within the enclosure because of improper installation.

Mounting Clips Tightening and Torque Sequence

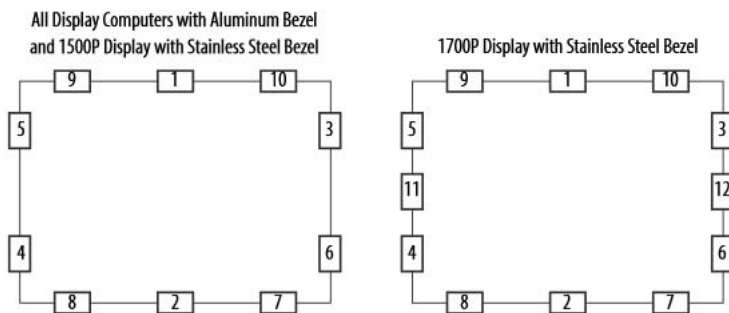

Mount the Non-display Computer on a Wall

Four mounting screws secure the non-display computers to a wall. Follow these steps to mount a non-display computer.

1. Verify the power is disconnected.
2. Mount the computer to a wall by using four M5 pan head screws and tighten to a torque that is appropriate for the screw and wall material.

The illustration shows hole locations with the dimensions in mm (in.).

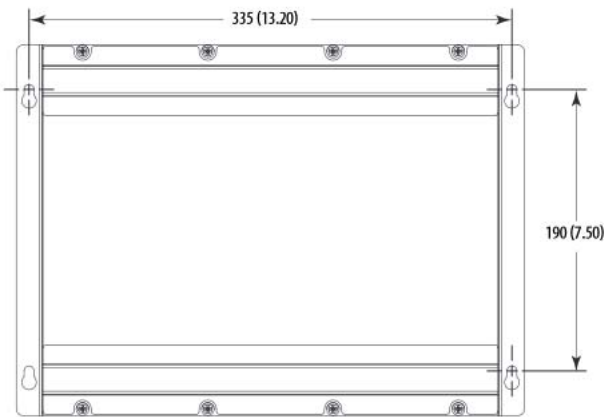

Connect Peripherals

Connect the required necessary peripherals such as keyboard and mouse.

Display computers with aluminum bezels have a front USB port for USB peripherals. This port is enabled or disabled through settings in the BIOS set-up menu.

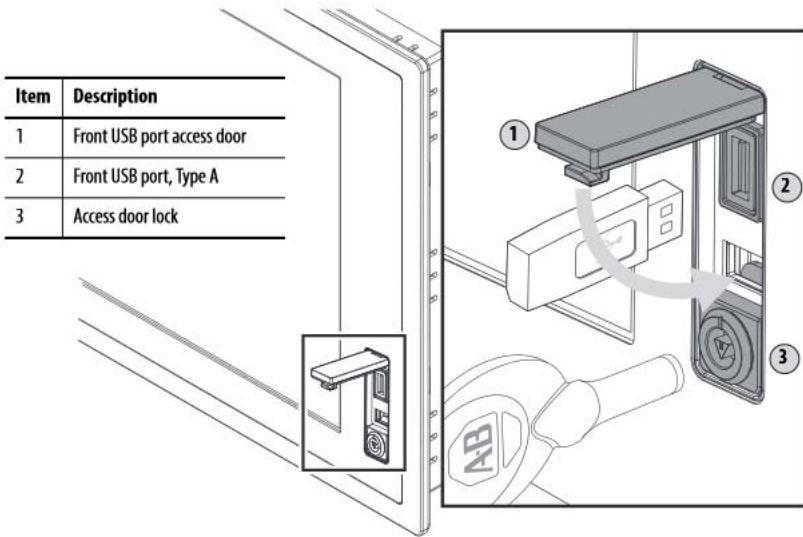

Performance and Non-display Models

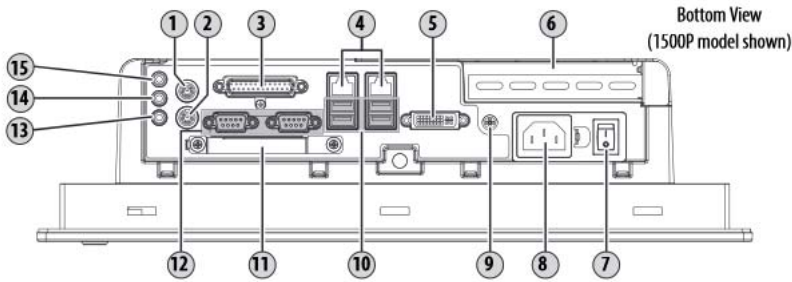

Item	Component
1	PS/2 mouse port
2	PS/2 keyboard port
3	Parallel port
4	Ethernet ports (RJ45), 2
5	DVI-I port
6	PCI riser slot cover ⁽¹⁾
7	Power switch
8	Power input, AC or DC ⁽²⁾

Item	Component
9	Functional ground screw
10	USB ports, 4
11	CompactFlash Type II card slot
12	Serial COM ports, 2
13	Microphone-in jack
14	Audio line-out jack
15	Audio line-in jack

(1) 1500P and 1700P have one PCI riser slot; 1200P and non-display computers have two PCI riser slots.
 (2) Model dependent.

Standard Model

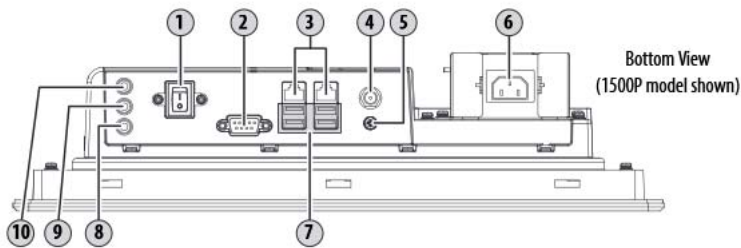

Item	Component
1	Power switch
2	Serial COM port
3	Ethernet ports (RJ45), 2
4	Power input, DC
5	Functional ground screw

Item	Component
6	Power input, AC
7	USB ports, 4
8	Microphone-in jack
9	Audio line-out jack
10	Audio line-in jack

Apply Power

The computer connects to either a 100...240V AC or 18...32V DC power source, depending on the model.



SHOCK HAZARD: Connect the AC power cord or the DC ground connection to a power source with an earth ground. Failure to follow this warning could result in electrical shock.

We recommend that the computer circuit has its own disconnect. Use an uninterruptible power source (UPS) to protect against unexpected power failure or power surges.

Always shut down the operating system before removing power to minimize performance degradation and operating system failures.

Remove the AC retention clip, if necessary, before installing the computer in a panel cutout. Reattach the clip after installing the computer.

Connect AC Power to Performance and Non-display Computers

A grounded 3-prong IEC320 power cord provides power to a computer with an AC power input. The power supply input accepts 100...240V AC and is autoranging.

TIP If using an alternate IEC320 cord, make sure the female end of the cord is sized appropriately for the retention clip.

Follow these steps to connect AC power to performance and non-display computers.

1. Connect the power cord to the AC power input (1).
2. Secure the power cord in place with the retention clip (2).

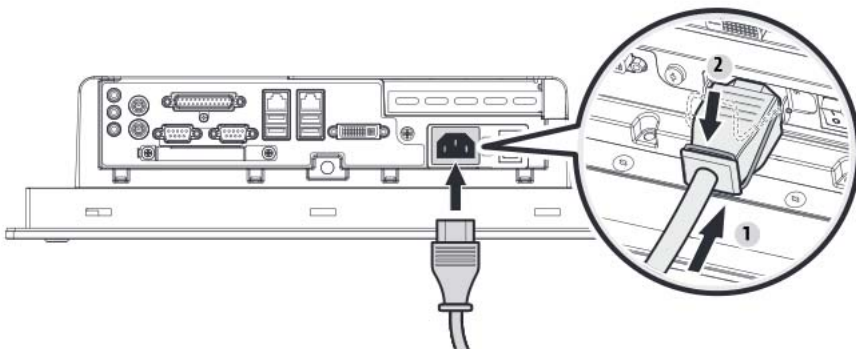

3. Apply 100...240V AC power to the computer.

Connect AC Power to Standard Computers

Follow these steps to connect AC power to the standard computers.

1. Connect the power cord to the AC power input (1).
2. Secure it in place with the retention clip (2).

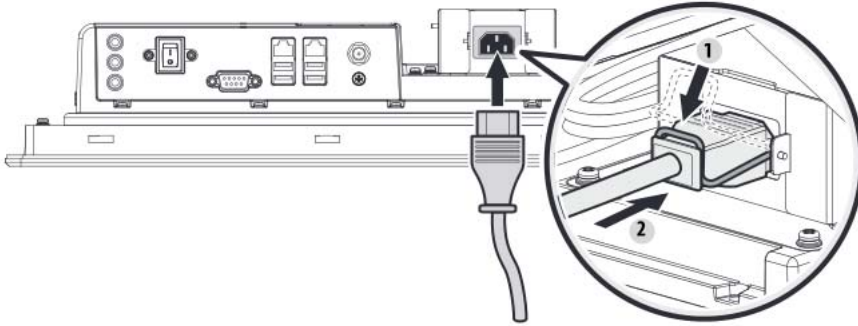

3. Connect the DC barrel connector to the power input jack (3).
4. Twist the locking ring clockwise to secure it in place (4).

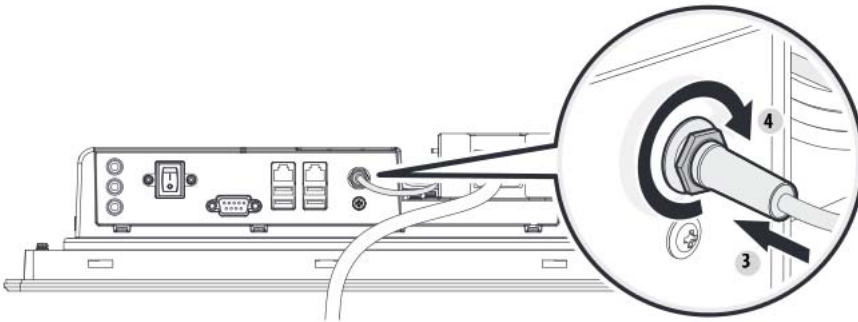

5. Apply 100...240V AC power to the computer.

Connect DC Power to Performance and Non-display Computers

Performance and non-display computers with a catalog number ending in DC have a DC input terminal block for connecting to a 18...32V DC power source.

The DC power option supports operation from either safety extra-low voltage (SELV) or protected extra-low voltage (PELV) power source. A ground bus strip is provided that lets you connect the DC common and functional ground terminals together. This is to support SELV cases where the end user requires grounding at the computer.

The power supply is internally protected against reverse polarity.



ATTENTION: Use a SELV isolated and ungrounded power supply as input power to the computer. This power source provides protection so that under normal and single fault conditions, the voltage between the conductors and functional earth/protective earth does not exceed a safe value.

Follow these steps to connect the computer to a DC power source.

1. Verify the main power switch or breaker is off.
2. Verify that the DC power wires meet these requirements:
 - Material: Stranded copper
 - Wire gauge: 0.325...0.823 mm² (22...18 AWG)
3. Secure the DC power wires to the terminal block screws, and the ground wire to the GND terminal screw.

Tighten the terminal to a torque of 0.687 N•m (6.1 lb•in).
4. Apply 18...32V DC power to the computer.

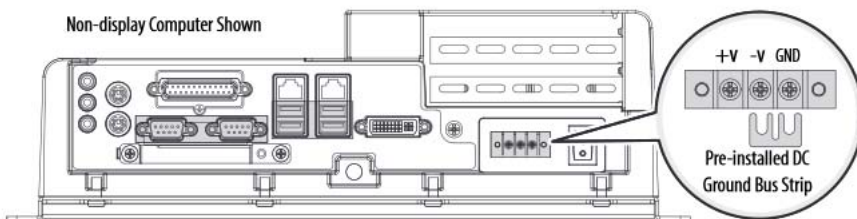

Functional Ground Screw

The pre-installed functional ground screw is not required for safety or regulatory compliance. However, if a supplemental ground is desired, use the functional ground screw in the I/O port panel of the computer.

If using the functional ground screw, connect the computer to earth ground by using a 1.5 mm (16 AWG) or larger external wire. Use a ground wire with green insulation and a yellow stripe for easy identification.

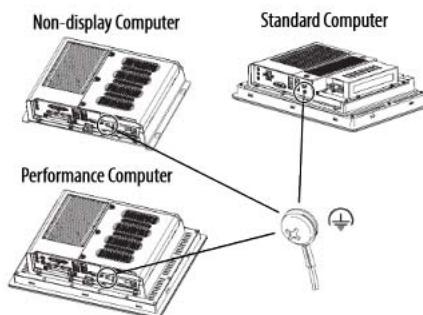

Connect to a Network

The computers have 2 Gb LAN ports. The computers connect to an Ethernet network by using CAT5 or CAT5E twisted-pair Ethernet cabling with RJ45 connectors.

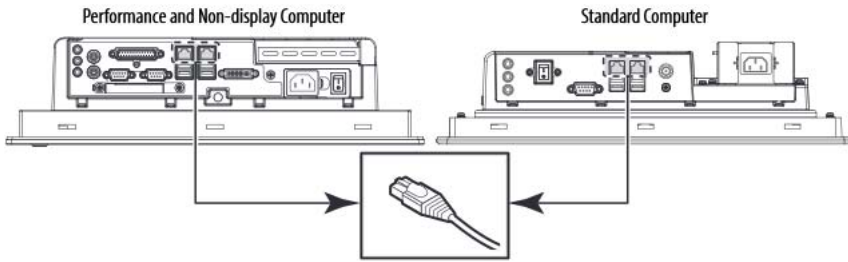

IMPORTANT To prevent performance degradation of Ethernet communication, do not subject the computer or cables to extreme radiation or conducted high-frequency noise.

Proper cable routing and power conditioning is required to be sure of reliable Ethernet communication in an industrial environment. Rockwell Automation recommends that you route all Ethernet cabling through dedicated metal conduits. Installing ferrite bead filters at the cable ends can also improve reliability.

Real Time Clock (RTC) Battery

This computer contains a lithium battery that must be replaced during the life of the computer. The computers use nonvolatile memory that require a battery to retain system information when power is removed. The battery is beside the DIMM1 slot.

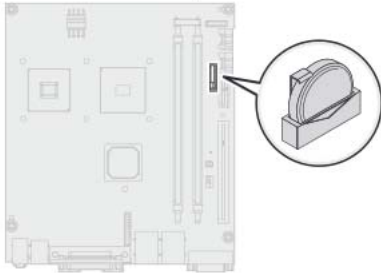

On-time (hrs/wk)	Expected Battery Life (yrs)
0	4
40	5.5
80	7

The battery life depends on the amount of time the computer is powered on.

If your computer does not display the correct time and date, replace the battery.



ATTENTION: Replace the battery with a specially-packaged replacement part from Allen-Bradley. Use of another battery may present a risk of fire or explosion.



At the end of its life, the used battery should be collected separately from any unsorted municipal waste and recycled.



ATTENTION: A risk of fire and chemical burn exists if the battery is not handled properly:

- Do not disassemble, crush, puncture, or short external contacts.
- Do not expose the battery to temperatures higher than 85 °C (185 °F).
- Do not dispose of a used battery in water or fire.

For safety information on handling lithium batteries, see *Guidelines for Handling Lithium Batteries*, publication [AG-5.4](#).

IMPORTANT

Replacing the battery results in all BIOS settings returning to their default settings. BIOS settings other than default must be reconfigured after replacing the battery.

Ship or Transport the Computer

If you need to ship the computer via common carrier or otherwise transport it to another location, you must first uninstall the computer and place it in its original packing material.



ATTENTION: Do not ship or transport the computer when it is installed in a machine, panel, or rack. Doing so can cause damage to the computer.

You must uninstall the computer and place it in its original packing material before shipping. Rockwell Automation is not responsible for damage incurred to a computer that is shipped or transported while installed in a machine, panel, or rack.

Specifications

Refer to the Industrial Integrated Display Computers User Manual, publication [6181P-UM002](#), for additional specifications.

Electrical

Attribute	6181F, 6181P
Performance and non-display, AC	
Input voltage, AC	100...240V AC, autoranging
Line frequency	47...63 Hz
Power consumption, AC	110VA (0.95 A @ 100V rms, 0.46 A @ 240V rms)
Performance and non-display, DC	
Input voltage, DC	18...32V DC
Power consumption, DC	95 W (5.28 A @ 18V, 2.97 A @ 32V)
Standard models	
Input voltage, AC	100...240 V AC, autoranging
Line frequency	47...63 Hz
Input voltage, DC ⁽¹⁾	20V DC (3.25 A)
Power consumption, AC	100VA (1 A @ 100V rms, 0.42 A @ 240V rms)
Heat dissipation ⁽²⁾	65 W (222 BTU/hr)

(1) Power adapter required.

(2) Add-in cards and peripherals are not included in the heat dissipation value. Calculate heat dissipation separately for installed add-in cards and peripherals.

Mechanical

Attribute	6181F, 6181P
Weight, approx	
Non-display	7.7 kg (16.98 lb)
1200P Performance	9.5 kg (20.94 lb)
1200P Standard	7.85 kg (17.31 lb)
1500P Performance	10.7 kg (23.59 lb)
1500P Performance w/stainless steel bezel	11.9 kg (26.24 lb)
1500P Standard	9.0 kg (19.84 lb)
1700P Performance	12.6 kg (27.78 lb)
1700P Performance w/stainless steel bezel	14.5 kg (31.97 lb)
1700P Standard	11.0 kg (24.25 lb)
Dimensions, overall (HxWxD, approx)	
Non-display	251 x 353 x 108 mm (7.5 x 13.20 x 4.25 in.)
1200P Performance	279 x 349 x 124 mm (10.98 x 13.74 x 4.90 in.)
1200P Standard	279 x 349 x 99 mm (10.98 x 13.74 x 3.91 in.)
1500P Performance	309 x 410 x 100 mm (12.16 x 16.14 x 3.94 in.)
1500P Standard	309 x 410 x 95 mm (12.16 x 16.14 x 3.74 in.)
1700P Performance	356 x 452 x 100 mm (14.01 x 17.80 x 3.94 in.)
1700P Standard	356 x 452 x 95 mm (14.01 x 17.80 x 3.74 in.)
Enclosure ratings (for display models only) ⁽¹⁾	
Performance	NEMA Type 1, 12, 4, and IEC IP66
Performance w/stainless steel bezel	NEMA Type 1, 12, 4, 4X, and IEC IP66
Standard	NEMA Type 1, 12, 4, and IEC IP66

(1) Type ratings apply only when computer is properly mounted on a flat surface of an equivalent type enclosure.

Environmental

Attribute	6181F, 6181P
Temperature, operating ⁽¹⁾	
All Standard models	0...50 °C (32...122 °F)
Non-display	0...55 °C (32...131 °F)
1200P and 1500P Performance	0...55 °C (32...131 °F)
1700P Performance	0...50 °C (32...122 °F)
Temperature, nonoperating ⁽¹⁾	-20...60 °C (-4...140 °F)
Relative humidity	10...90% noncondensing
Altitude, operating	2000 m (6561 ft)
Altitude, nonoperating	12,000 m (40,000 ft)
Shock, operating ⁽¹⁾⁽²⁾	15 g (1/2 sine, 11 ms)
Shock, nonoperating ⁽¹⁾⁽²⁾	30 g (1/2 sine, 11 ms)
Vibration, operating ⁽¹⁾⁽²⁾	
6181F	0.012 in. p-p, (10...57 Hz); 2 g peak, (57...640 Hz)
6181P	0.006 in. p-p, (10...57 Hz); 1 g peak, (57...640 Hz)
Vibration, nonoperating ⁽¹⁾⁽²⁾	0.012 in. p-p, (10...57 Hz); 2 g peak, (57...640 Hz)

(1) The optical disc drive (ODD) is considered a maintenance device. Therefore, do not operate computers with ODDs in temperatures above 45 °C (113 °F) or in environments with the shock and vibration levels listed.

(2) Applies only to panel mounted display computers and wall mounted non-display computers.

Certifications ⁽¹⁾

Attribute	6181F, 6181P
c-UL-us	UL/c-UL Listed per UL 60950-1 and CSA C22.2 No. 60950-1-03
CE	Marked for all applicable directives EMC 2004/108/EC LVD 2006/95/EC
C-Tick	Australian Radiocommunications Act, compliant with: AS/NZS CISPR 11; Industrial Emissions
RoHS	China RoHS Turkey RoHS (EEE Yönetmeliğine Uygundur. In Conformity with the EEE Regulation)

(1) See <http://www.rockwellautomation.com/rockwellautomation/certification/overview.page> for declarations of conformity, certificates, and other certification details.

Additional Resources

These documents contain additional information about related products from Rockwell Automation.

Resource	Description
Industrial Integrated Display Computer User Manual, publication 6181P-UM002	Provides a system overview and procedures to install the computer, set up computer connections, operate the computer, and troubleshoot the computer.
Cloning Utility Technical Data, publication 6000-TD002	Provides information on how to create and restore a back-up image of your computer's hard drive.
Diagnostic Utility for Industrial Computers, publication 6000-TG001	Provides information on how to diagnose hardware issues with industrial computers.
EFW and HORM Configuration Utility Technical Data, publication 6000-TD003	Provides information on how to configure Enhanced Write Filter (EFW) and Hibernate Once Restore Many (HORM) features for computers with the Windows Embedded Standard 2009 operating system.

You can view or download publications at <http://www.rockwellautomation.com/literature>. To order paper copies of technical documentation, contact your local Allen-Bradley distributor or Rockwell Automation sales representative.

Allen-Bradley, Rockwell Software, and Rockwell Automation are trademarks of Rockwell Automation, Inc.

Trademarks not belonging to Rockwell Automation are property of their respective companies.

Rockwell Otomasyon Ticaret A.Ş., Kar Plaza İş Merkezi E Blok Kat:6 34752 İçerenköy, İstanbul, Tel: +90 (216) 5698400

www.rockwellautomation.com

Power, Control and Information Solutions Headquarters

Americas: Rockwell Automation, 1201 South Second Street, Milwaukee, WI 53204-2496 USA, Tel: (1) 414.382.2000, Fax: (1) 414.382.4444
Europe/Middle East/Africa: Rockwell Automation NV, Pegasus Park, De Kleeflaan 12a, 1831 Diegem, Belgium, Tel: (32) 2 663 0600, Fax: (32) 2 663 0640
Asia Pacific: Rockwell Automation, Level 14, Core F, Cyberport 3, 100 Cyberport Road, Hong Kong, Tel: (852) 2887 4788, Fax: (852) 2508 1846

Publication 6181P-IN010F-EN-P - July 2013

Supersedes Publication 6181P-IN010F-EN-P - September 2012



PN-30419

DIR 10000039347 (Version 02)

Copyright © 2013 Rockwell Automation, Inc. All rights reserved. Printed in China.