

## 1756-IB16

ControlLogix DC (10...31.2V) input module

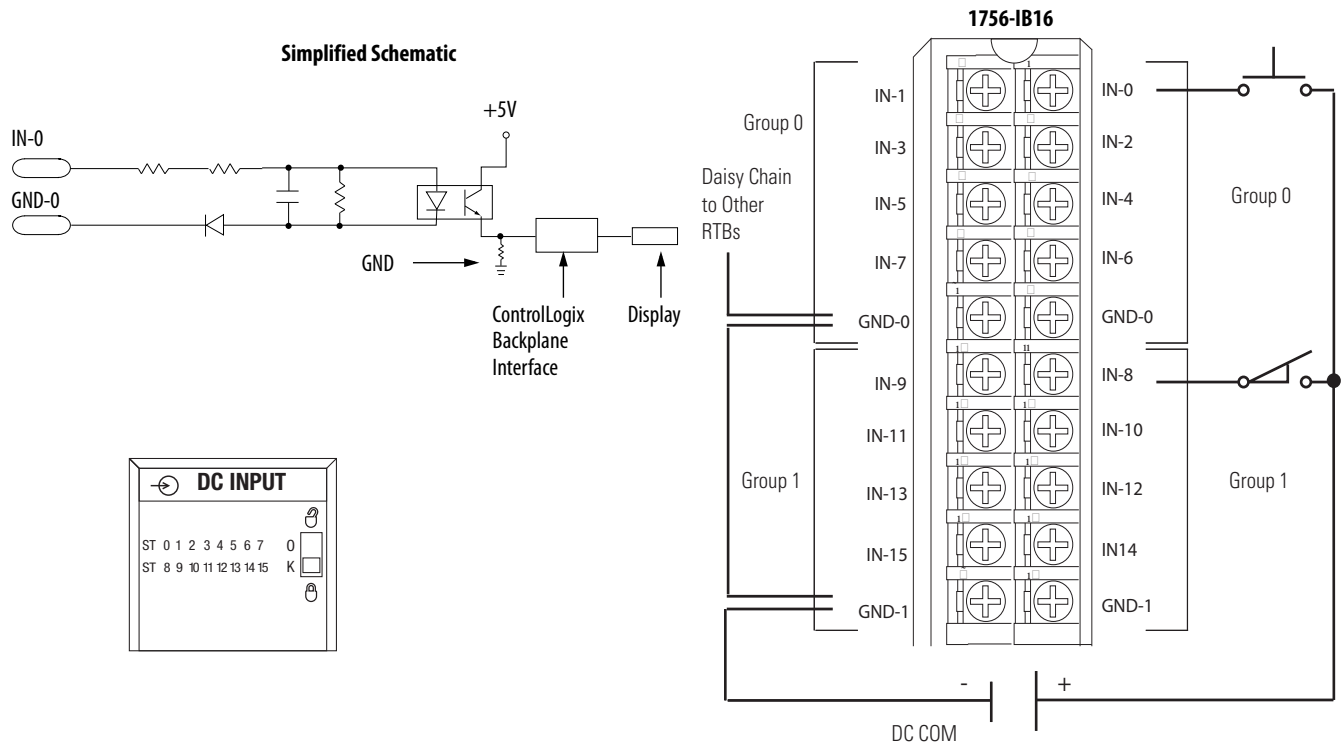

**Table 14 - Technical Specifications - 1756-IB16**

Attribute	1756-IB16
Inputs	16 (8 points/group)
Voltage category	12/24V DC sink
Operating voltage range	10...31.2V DC
Input voltage, nom	24V DC
Input delay time (screw to backplane)	
Off to On	Hardware delay: 290 $\mu$ s nom/1 ms max + filter time User-selectable filter time: 0, 1, or 2 ms
On to Off	Hardware delay: 700 $\mu$ s nom/2 ms max + filter time User-selectable filter time: 0, 1, 2, 9, or 18 ms
Current draw @ 5.1V	100 mA
Current draw @ 24V	2 mA
Total backplane power	0.56 W
Power dissipation, max	5.1 W @ 60 °C (140 °F)
Thermal dissipation	17.39 BTU/hr
Off-state voltage, max	5V
Off-state current, max	1.5 mA
On-state current, min	2 mA @ 10V DC
On-state current, max	10 mA @ 31.2V DC

**Table 14 - Technical Specifications - 1756-IB16 (continued)**

Attribute	1756-IB16
Inrush current, max	250 mA peak (decaying to < 37% in 22 ms, without activation)
Input impedance, max	3.12 k $\Omega$ @ 31.2V DC
Cyclic update time	200 $\mu$ s . . . 750 ms
Change of state	Software configurable
Timestamp of inputs	$\pm$ 200 $\mu$ s
Isolation voltage	250V (continuous), basic insulation type, inputs-to-backplane, and input group-to-group No isolation between individual group inputs Routine tested @ 1350V AC for 2 s
Module keying	Electronic, software configurable
Removable terminal block housing	1756-TBNH 1756-TBSH
RTB keying	User-defined mechanical
Slot width	1
Wire category	1 <sup>(1)</sup>
North American temperature code	T3C
IEC temperature code	T3
Enclosure type	None (open-style)
Reverse polarity protection	Yes

(1) Use this conductor category information for planning conductor routing as described in the system-level installation manual. See the Industrial Automation Wiring and Grounding Guidelines, publication [1770-4.1](#).

**Table 15 - Environmental Specifications - 1756-IB16**

Attribute	1756-IB16
Temperature, operating IEC 60068-2-1 (Test Ad, Operating Cold), IEC 60068-2-2 (Test Bd, Operating Dry Heat), IEC 60068-2-14 (Test Nb, Operating Thermal Shock)	0 . . . 60 °C (32 . . . 140 °F)
Temperature, surrounding air, max	60 °C (140 °F)
Temperature, nonoperating IEC 60068-2-1 (Test Ab, Unpackaged Nonoperating Cold), IEC 60068-2-2 (Test Bb, Unpackaged Nonoperating Dry Heat), IEC 60068-2-14 (Test Na, Unpackaged Nonoperating Thermal Shock)	-40 . . . 85 °C (-40 . . . 185 °F)
Relative humidity IEC 60068-2-30 (Test Db, Unpackaged Damp Heat)	5 . . . 95% noncondensing
Vibration IEC 60068-2-6 (Test Fc, Operating)	2 g @ 10 . . . 500 Hz
Shock, operating IEC 60068-2-27 (Test Ea, Unpackaged Shock)	30 g
Shock, nonoperating IEC 60068-2-27 (Test Ea, Unpackaged Shock)	50 g
Emissions	CISPR 11 (IEC 61000-6-4): Class A
ESD immunity IEC 61000-4-2	6 kV contact discharges 8 kV air discharges

**Table 15 - Environmental Specifications - 1756-IB16 (continued)**

Attribute	1756-IB16
Radiated RF immunity IEC 61000-4-3	10V/m with 1kHz sine-wave 80% AM from 80... 2000 MHz 10V/m with 200 Hz 50% Pulse 100% AM @ 900 MHz 10V/m with 200 Hz 50% Pulse 100% AM @ 1890 MHz 3V/m with 1kHz sine-wave 80% AM from 2000... 2700 MHz
EFT/B immunity IEC 61000-4-4	±4 kV at 5 kHz on signal ports
Surge transient immunity IEC 61000-4-5	±1 kV line-line (DM) and ±2 kV line-earth (CM) on signal ports
Conducted RF immunity IEC 61000-4-6	10V rms with 1 kHz sine-wave 80% AM from 150 kHz... 80 MHz
Oscillatory surge withstand IEEE C37.90.1	3 kV

**Table 16 - Certifications - 1756-IB16**

Certification <sup>(1)</sup>	1756-IB16
UL	UL Listed Industrial Control Equipment. See UL File E65584.
CSA	CSA Certified Process Control Equipment. See CSA File LR54689C. CSA Certified Process Control Equipment for Class I, Division 2 Group A,B,C,D Hazardous Locations. See CSA File LR69960C.
CE	European Union 2004/108/IEC EMC Directive, compliant with: <ul style="list-style-type: none"> <li>EN 61326-1; Meas./Control/Lab., Industrial Requirements</li> <li>EN 61000-6-2; Industrial Immunity</li> <li>EN 61000-6-4; Industrial Emissions</li> <li>EN 61131-2; Programmable Controllers (Clause 8, Zone A &amp; B)</li> </ul> European Union 2006/95/EC LVD, compliant with: EN 61131-2; Programmable Controllers (Clause 11)
C-Tick	Australian Radiocommunications Act, compliant with: AS/NZS CISPR 11; Industrial Emissions
Ex	European Union 94/9/EC ATEX Directive, compliant with: <ul style="list-style-type: none"> <li>EN 60079-15; Potentially Explosive Atmospheres, Protection "n"</li> <li>EN 60079-0; General Requirements II 3 G Ex nA IIC T3 X Gc</li> </ul>
FM	FM Approved Equipment for use in Class I Division 2 Group A,B,C,D Hazardous Locations
KC	Korean Registration of Broadcasting and Communications Equipment, compliant with: Article 58-2 of Radio Waves Act, Clause 3

(1) When marked. See the Product Certification link at <http://www.ab.com> for Declarations of Conformity, Certificates, and other certification details.