

1756-IB32

ControlLogix DC (10...31.2V) input module

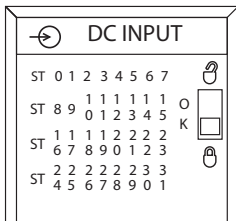
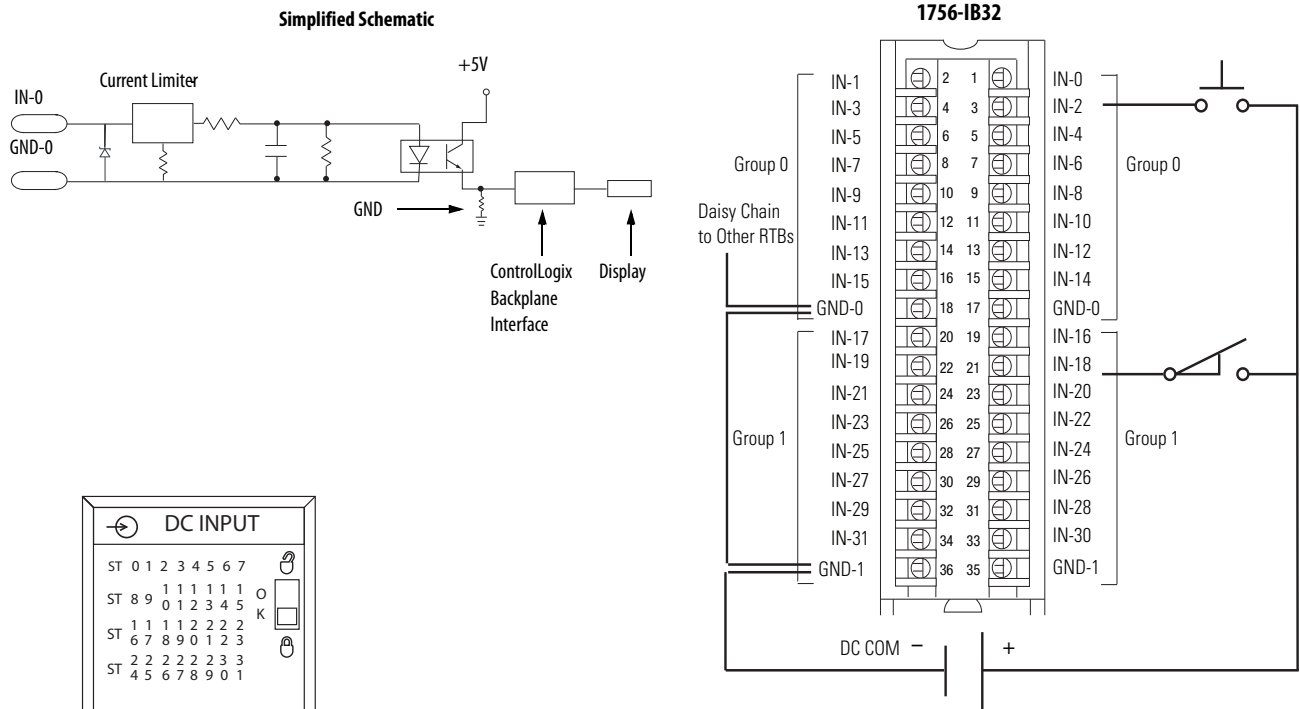

Technical Specifications - 1756-IB32

Attribute	1756-IB32
Inputs	32 (16 points/group)
Voltage category	12/24V DC sink
Operating voltage range	10...31.2V DC
Input voltage, nom	24V DC
Input delay time (screw to backplane)	
Off to On	Hardware delay: 380 μ s max + filter time User-selectable filter time: 0 ms, 1 ms, or 2 ms
On to Off	Hardware delay: 420 μ s max + filter time User-selectable filter time: 0 ms, 1 ms, 2 ms, 9 ms, or 18 ms
Current draw @ 5.1V	120 mA
Current draw @ 24V	2 mA
Total backplane power	0.66 W
Power dissipation, max	6.2 W @ 60 °C (140 °F)
Thermal dissipation	21.1 BTU/hr @ 60 °C (140 °F)
Off-state voltage, max	5V
Off-state current, max	2.27 mA
On-state current, min	4.8 mA @ 10V DC
On-state current, max	5.5 mA @ 31.2V DC
Inrush current, max	250 mA (decaying to < 37% in 22 ms, without activation)

Technical Specifications - 1756-IB32 (continued)

Attribute	1756-IB32
Input impedance, max	5.67 k Ω @ 31.2V DC
Cyclic update time	200 μ s...750 ms
Change of state	Software configurable
Time stamp of inputs	\pm 200 μ s
Isolation voltage	250V (continuous), reinforced insulation type, inputs-to-backplane 250V (continuous), basic insulation type, input group-to-group No isolation between individual group inputs Routine tested @ 1350V AC for 2 s
Module keying	Electronic, software configurable
Removable terminal block	1756-TBCH 1756-TBS6H
RTB keying	User-defined mechanical
Slot width	1
Wire category	1 - on signal ports ⁽¹⁾
North American temperature code	T4
IEC temperature code	T4
Enclosure type	None (open-style)
Reverse polarity protection	Yes

(1) Use this conductor category information for planning conductor routing as described in the system-level installation manual. See the Industrial Automation Wiring and Grounding Guidelines, publication [1770-4.1](#).

Environmental Specifications - 1756-IB32

Attribute	1756-IB32
Temperature, operating IEC 60068-2-1 (Test Ad, Operating Cold), IEC 60068-2-2 (Test Bd, Operating Dry Heat), IEC 60068-2-14 (Test Nb, Operating Thermal Shock)	0...60 °C (32...140 °F)
Temperature, surrounding air, max	60 °C (140 °F)
Temperature, nonoperating IEC 60068-2-1 (Test Ab, Unpackaged Nonoperating Cold), IEC 60068-2-2 (Test Bb, Unpackaged Nonoperating Dry Heat), IEC 60068-2-14 (Test Na, Unpackaged Nonoperating Thermal Shock)	-40...+85 °C (-40...+185 °F)
Relative humidity IEC 60068-2-30 (Test Db, Unpackaged Damp Heat)	5...95% noncondensing
Vibration IEC 60068-2-6 (Test Fc, Operating)	2 g @ 10...500 Hz
Shock, operating IEC 60068-2-27 (Test Ea, Unpackaged Shock)	30 g
Shock, nonoperating IEC 60068-2-27 (Test Ea, Unpackaged Shock)	50 g
Emissions	CISPR 11, Class A
ESD immunity IEC 61000-4-2	6 kV contact discharges 8 kV air discharges
Radiated RF immunity IEC 61000-4-3	10V/m with 1 kHz sine-wave 80% AM from 80...2000 MHz 10V/m with 200 Hz 50% Pulse 100% AM @ 900 MHz 10V/m with 200 Hz 50% Pulse 100% AM @ 1890 MHz 3V/m with 1 kHz sine-wave 80% AM from 2000...2700 MHz
EFT/B immunity IEC 61000-4-4	\pm 4 kV at 5 kHz on signal ports

Environmental Specifications - 1756-IB32 (continued)

Attribute	1756-IB32
Surge transient immunity IEC 61000-4-5	±1 kV line-line (DM) and ±2 kV line-earth (CM) on signal ports
Conducted RF immunity IEC 61000-4-6	10V rms with 1 kHz sine-wave 80% AM from 150 kHz . . . 80 MHz
Oscillatory surge withstand IEEE C37.90.1	3 kV

Certifications - 1756-IB32

Certification ⁽¹⁾	1756-IB32
c-UL-us	UL Listed Industrial Control Equipment, certified for US and Canada. See UL File E65584. UL Listed for Class I, Division 2 Group A,B,C,D Hazardous Locations, certified for U.S. and Canada. See UL File E194810.
CSA	CSA Certified Process Control Equipment. See CSA File LR54689C. CSA Certified Process Control Equipment for Class I, Division 2 Group A,B,C,D Hazardous Locations. See CSA File LR69960C.
CE	European Union 2004/108/EC EMC Directive, compliant with: <ul style="list-style-type: none"> • EN 61326-1; Meas./Control/Lab., Industrial Requirements • EN 61000-6-2; Industrial Immunity • EN 61000-6-4; Industrial Emissions • EN 61131-2; Programmable Controllers (Clause 8, Zone A & B) European Union 2006/95/EC LVD, compliant with: EN 61131-2; Programmable Controllers (Clause 11)
C-Tick	Australian Radiocommunications Act, compliant with: AS/NZS CISPR 11; Industrial Emissions
Ex	European Union 94/9/EC ATEX Directive, compliant with: <ul style="list-style-type: none"> • EN 60079-15; Potentially Explosive Atmospheres, Protection "n" • EN 60079-0; General Requirements II 3 G Ex nA IIC T4 X Gc
FM	FM Approved Equipment for use in Class I Division 2 Group A,B,C,D Hazardous Locations
KC	Korean Registration of Broadcasting and Communications Equipment, compliant with: Article 58-2 of Radio Waves Act, Clause 3

(1) When marked. See the Product Certification link at <http://www.ab.com> for Declarations of Conformity, Certificates, and other certification details.