

### 1756-0W16I

ControlLogix AC (10...240V) DC (5...125V) isolated contact module

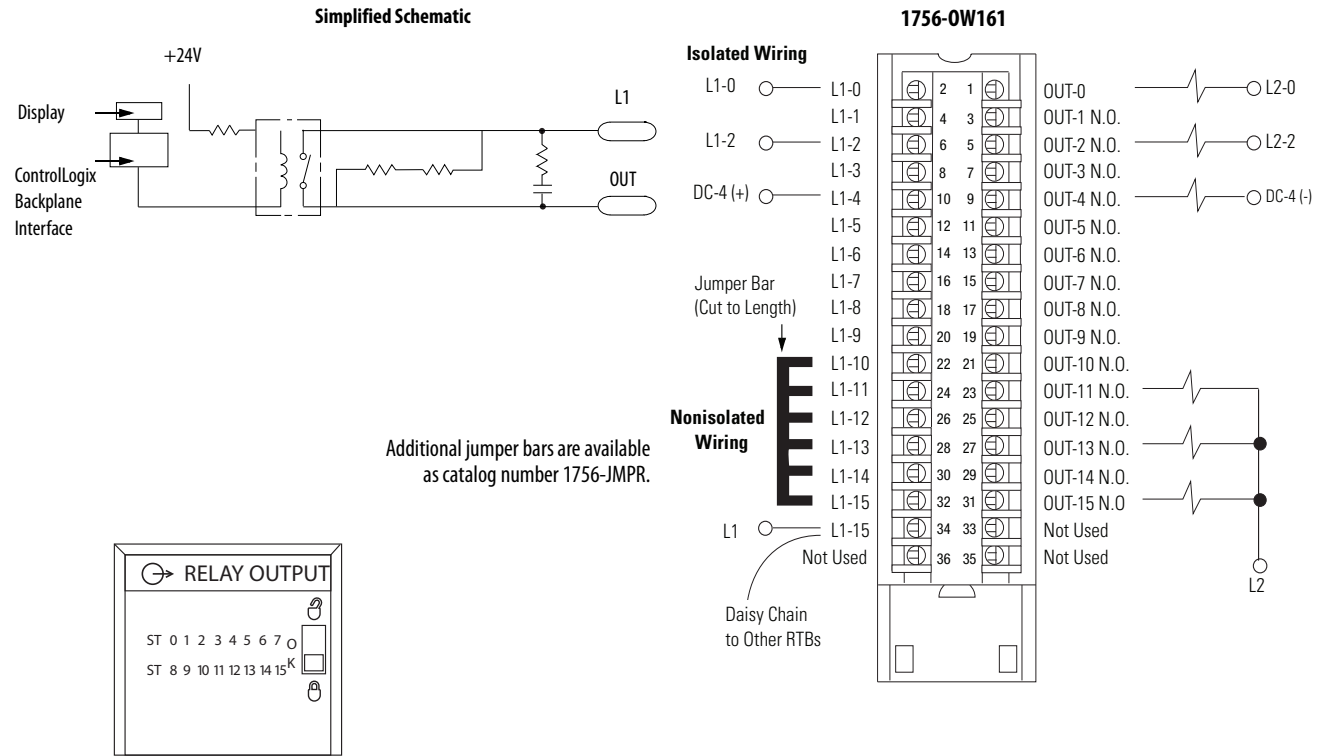

### Technical Specifications - 1756-0W16I

Attribute	1756-0W16I
Outputs	16 N.O. individually isolated
Pilot duty	C300/R150
Operating voltage range	5...125V DC 10...240V AC
Output voltage range (load dependent)	1 A @ 5...30V DC 0.5 A @ 48V DC 0.22 A @ 125V DC 1.5 A @ 120V AC 50/60 Hz 0.75 A @ 240V AC 50/60 Hz
Output delay time	
Off to On	10 ms max
On to Off	10 ms max
Current draw @ 5.1V	150 mA
Current draw @ 24V	150 mA
Total backplane power	4.4 W
Power dissipation, max	4.5 W @ 60 °C (140 °F)
Thermal dissipation	15.35 BTU/hr
Off-state leakage current per point, max	1.5 mA per point
Minimum load current	10 mA per point
Initial contact resistance, max	100 mΩ @ 6V 1 A

**Technical Specifications - 1756-0W16I (continued)**

Attribute	1756-0W16I
Switching frequency, max	1 operation/3 s (0.3 Hz at rated load)
Bounce time, mean	1.2 ms
Expected contact life	300 kHz resistive 100 kHz inductive
Scheduled outputs	Synchronization within 16.7 s max, reference to the Coordinated System Time
States in Fault mode per point	Hold last state, On or Off (Off is default)
States in Program mode per point	Hold last state, On or Off (Off is default)
Isolation voltage	250V (continuous), basic insulation type, outputs-to-backplane, and output-to-output Routine tested @ 1350V AC for 2 s
Module keying	Electronic, software configurable
Fusing	Not protected. A fused IFM can be used to help protect outputs. See publication <a href="#">1492-TD008</a> . However, the ControlLogix system has been agency certified using only the ControlLogix RTBs, that is, 1756-TBCH, 1756-TBNH, 1756-TBSH, and 1756-TBS6H. Any application that requires agency certification of the ControlLogix system using other wiring termination methods can require application-specific approval by the certifying agency.
Removable terminal block	1756-TBCH 1756-TBS6H
RTB keying	User-defined mechanical
Slot width	1
Wire category	1 <sup>(1)</sup>
North American temperature code	T4A
Enclosure type	None (open-style)

(1) Use this conductor category information for planning conductor routing as described in the system-level installation manual. See the Industrial Automation Wiring and Grounding Guidelines, publication [1770-4.1](#).

**Environmental Specifications - 1756-0W16I**

Attribute	1756-0W16I
Temperature, operating IEC 60068-2-1 (Test Ad, Operating Cold), IEC 60068-2-2 (Test Bd, Operating Dry Heat), IEC 60068-2-14 (Test Nb, Operating Thermal Shock)	0...60 °C (32...140 °F)
Temperature, surrounding air, max	60 °C (140 °F)
Temperature, nonoperating IEC 60068-2-1 (Test Ab, Unpackaged Nonoperating Cold), IEC 60068-2-2 (Test Bb, Unpackaged Nonoperating Dry Heat), IEC 60068-2-14 (Test Na, Unpackaged Nonoperating Thermal Shock)	-40...+85 °C (-40...+185 °F)
Relative humidity IEC 60068-2-30 (Test Db, Unpackaged Damp Heat)	5...95% noncondensing
Vibration IEC 60068-2-6 (Test Fc, Operating)	2 g @ 10...500 Hz
Shock, operating IEC 60068-2-27 (Test Ea, Unpackaged Shock)	30 g
Shock, nonoperating IEC 60068-2-27 (Test Ea, Unpackaged Shock)	50 g
Emissions	CISPR 11, Class A
ESD immunity IEC 61000-4-2	6 kV contact discharges 8 kV air discharges

**Environmental Specifications - 1756-0W161 (continued)**

Attribute	1756-0W161
Radiated RF immunity IEC 61000-4-3	10V/m with 1 kHz sine-wave 80% AM from 80 . . .2000 MHz 10V/m with 200 Hz 50% Pulse 100% AM @ 900 MHz 10V/m with 200 Hz 50% Pulse 100% AM @ 1890 MHz 3V/m with 1 kHz sine-wave 80% AM from 2000 . . .2700 MHz
EFT/B immunity IEC 61000-4-4	±4 kV at 5 kHz on signal ports
Surge transient immunity IEC 61000-4-5	±1 kV line-line (DM) and ±2 kV line-earth (CM) on signal ports
Conducted RF immunity IEC 61000-4-6	10V rms with 1 kHz sine-wave 80% AM from 150 kHz . . .80 MHz
Oscillatory surge withstand IEEE C37.90.1	3 kV

**Certifications - 1756-0W161**

Certification <sup>(1)</sup>	1756-0W161
UL	UL Listed Industrial Control Equipment. See UL File E65584.
CSA	CSA Certified Process Control Equipment. See CSA File LR54689C. CSA Certified Process Control Equipment for Class I, Division 2 Group A,B,C,D Hazardous Locations. See CSA File LR69960C.
CE	European Union 2004/108/IEC EMC Directive, compliant with: <ul style="list-style-type: none"> <li>• EN 61326-1; Meas./Control/Lab., Industrial Requirements</li> <li>• EN 61000-6-2; Industrial Immunity</li> <li>• EN 61000-6-4; Industrial Emissions</li> <li>• EN 61131-2; Programmable Controllers (Clause 8, Zone A &amp; B)</li> </ul> European Union 2006/95/EC LVD, compliant with: EN 61131-2; Programmable Controllers
C-Tick	Australian Radiocommunications Act, compliant with: AS/NZS CISPR 11; Industrial Emissions
FM	FM Approved Equipment for use in Class I Division 2 Group A,B,C,D Hazardous Locations
KC	Korean Registration of Broadcasting and Communications Equipment, compliant with: Article 58-2 of Radio Waves Act, Clause 3

(1) When marked. See the Product Certification link at <http://www.ab.com> for Declarations of Conformity, Certificates, and other certification details.