

## 1756 ControlLogix Power Supplies Specifications

### Standard AC Power Supplies Catalog Numbers

1756-PA72, 1756-PA75

### Standard DC Power Supplies Catalog Numbers

1756-PB72, 1756-PB75, 1756-PC75, 1756-PH75

### ControlLogix-XT Power Supplies Catalog Numbers

1756-PAXT, 1756-PBXT

### Redundant Power Supplies Catalog Numbers

1756-PA75R, 1756-PB75R

Topic	Page
Standard AC Power Supplies	3
Standard DC Power Supplies	6
Redundant Power Supplies	10
1756 ControlLogix-XT Power Supplies	15

ControlLogix power supplies are used with the 1756 chassis to provide 1.2V, 3.3V, 5V, and 24V DC power directly to the chassis backplane. Standard and redundant power supplies are available.

## Important User Information

Solid state equipment has operational characteristics differing from those of electromechanical equipment. Safety Guidelines for the Application, Installation and Maintenance of Solid State Controls (publication [SGI-1.1](#) available from your local Rockwell Automation sales office or online at <http://www.rockwellautomation.com/literature/>) describes some important differences between solid state equipment and hard-wired electromechanical devices. Because of this difference, and also because of the wide variety of uses for solid state equipment, all persons responsible for applying this equipment must satisfy themselves that each intended application of this equipment is acceptable.

In no event will Rockwell Automation, Inc. be responsible or liable for indirect or consequential damages resulting from the use or application of this equipment.

The examples and diagrams in this manual are included solely for illustrative purposes. Because of the many variables and requirements associated with any particular installation, Rockwell Automation, Inc. cannot assume responsibility or liability for actual use based on the examples and diagrams.

No patent liability is assumed by Rockwell Automation, Inc. with respect to use of information, circuits, equipment, or software described in this manual.

Reproduction of the contents of this manual, in whole or in part, without written permission of Rockwell Automation, Inc., is prohibited.

Throughout this manual, when necessary, we use notes to make you aware of safety considerations.

---

**WARNING**

Identifies information about practices or circumstances that can cause an explosion in a hazardous environment, which may lead to personal injury or death, property damage, or economic loss.

---

**IMPORTANT**

Identifies information that is critical for successful application and understanding of the product.

---

**ATTENTION**

Identifies information about practices or circumstances that can lead to personal injury or death, property damage, or economic loss. Attentions help you identify a hazard, avoid a hazard, and recognize the consequence

---

**SHOCK HAZARD**

Labels may be on or inside the equipment, for example, a drive or motor, to alert people that dangerous voltage may be present.

---

**BURN HAZARD**

Labels may be on or inside the equipment, for example, a drive or motor, to alert people that surfaces may reach dangerous temperatures.

---

Rockwell Automation, Rockwell Software, Allen-Bradley, TechConnect, ControlLogix, ControlLogix-XT, and FLEX I/O-XT are trademarks of Rockwell Automation, Inc.

Trademarks not belonging to Rockwell Automation are property of their respective companies.

# Standard AC Power Supplies

## Technical Specifications - 1756 Standard AC Power Supplies

Attribute	1756-PA72/C	1756-PA75/B
Input voltage range	85...265V AC	
Input voltage, nom	120V/220V AC	
Input frequency range	47...63 Hz	
Input power, max	100VA/ 100 W	
Output power, max	75 W @ 0...60 °C (32...140 °F) <sup>(1)</sup>	
Power consumption	25 W @ 0...60 °C (32...140 °F)	
Power dissipation	85.3 BTU/hr	
Hold up time <sup>(2)</sup>	5 cycles @ 85V AC, 50/60 Hz 6 cycles @ 120V AC, 50/60 Hz 6 cycles @ 200V AC, 50/60 Hz 6 cycles @ 240V AC, 50/60 Hz	2 cycles @ 85V AC, 60 Hz 6 cycles @ 120V AC, 60 Hz 20 cycles @ 220V AC, 60 Hz
Inrush current, max	20 A	
Current capacity at 1.2V	1.5 A	
Current capacity at 3.3V	4 A	
Current capacity at 5.1V	10 A	13 A
Current capacity at 24V	2.8 A	
Overcurrent protection, max	User-supplied 15 A <sup>(3)</sup>	
Fusing	Non-replaceable fuse is soldered in place <sup>(4)</sup>	
Transformer load, max	100VA	
Isolation voltage	250V (continuous), reinforced insulation type Type tested @ 3500V DC for 60 s, power input-to-backplane	
Weight, approx.	0.95 kg (2.10 lb)	
Dimensions	140 x 112 x 145 mm (5.51 x 4.41 x 5.71 in.)	
Module location	Left side of 1756 chassis	Left side of 1756 chassis (series B only)
Chassis	1756-A4, 1756-A7, 1756-A10, 1756-A13, 1756-A17	
Chassis compatibility	Series A Series B	Series B
Wire category	1 - on power ports <sup>(5)</sup>	
Wire size	2.5 mm <sup>2</sup> (14 AWG) solid or stranded copper wire rated at 75 °C (167 °F), or greater, 1.2 mm (3/64 in.) insulation max	
Conductor screw torque	0.8 N•m (7 lb•in)	
North American temperature code	T4	
Enclosure type rating	None (open-style)	

<sup>(1)</sup> The combination of all output power (5.1V backplane, 24V backplane, 3.3V backplane, and 1.2V backplane) cannot exceed 75 W.

<sup>(2)</sup> The hold up time is the time between input voltage removal and DC power failure.

<sup>(3)</sup> Use time-delay type overcurrent protection in all ungrounded conductors.

<sup>(4)</sup> This fuse is intended to guard against fire hazard due to short circuit conditions.

<sup>(5)</sup> Use this conductor category information for planning conductor routing as described in the system level installation manual. See the Industrial Automation Wiring and Grounding Guidelines, publication [1770-4.1](#).

**Environmental Specifications - 1756 Standard AC Power Supplies**

<b>Attribute</b>	<b>1756-PA72/C, 1756-PA75/B</b>
Temperature, operating IEC 60068-2-1 (Test Ad, Operating Cold), IEC 60068-2-2 (Test Bd, Operating Dry Heat), IEC 60068-2-14 (Test Nb, Operating Thermal Shock)	0...60 °C (32...140 °F)
Temperature, storage IEC 60068-2-1 (Test Ab, Unpackaged Nonoperating Cold), IEC 60068-2-2 (Test Bb, Unpackaged Nonoperating Dry Heat), IEC 60068-2-14 (Test Na, Unpackaged Nonoperating Thermal Shock)	-40...85 °C (-40...185 °F)
Relative humidity IEC 60068-2-30 (Test Db, Unpackaged Nonoperating Damp Heat)	5...95% noncondensing
Vibration IEC 60068-2-6 (Test Fc, Operating)	2 g @ 10...500 Hz
Shock, operating IEC 60068-2-27 (Test Ea, Unpackaged Shock)	30 g
Shock, nonoperating IEC 60068-2-27 (Test Ea, Unpackaged Shock)	50 g
Emissions	CISPR 11: Group 1, Class A
ESD immunity IEC 61000-4-2	6kV contact discharges 8kV air discharges
Radiated RF immunity IEC 61000-4-3	10V/m with 1 kHz sine-wave 80% AM from 80... 2000 MHz 10V/m with 200 Hz 50% Pulse 100% AM @ 900 MHz 10V/m with 200 Hz 50% Pulse 100% AM @ 1890 MHz 3V/m with 1kHz sine-wave 80% AM from 2000...2700 MHz
EFT/B immunity IEC 61000-4-4	±4 kV at 5 kHz on signal ports
Surge transient immunity IEC 61000-4-5	±1 kV line-line (DM) and ±2 kV line-earth (CM) on signal ports
Conducted RF immunity IEC 61000-4-6	10Vrms with 1 kHz sine-wave 80% AM from 150 kHz...80 MHz
Oscillatory surge withstand IEEE C37.90.1	3 kV
Voltage variation IEC 61000-4-11	30% dips for 1 period at 0° and 80° on AC supply ports 60% dips for 5 and 50 periods on AC supply ports ±10% fluctuations for 15 min on AC supply ports >95% interruptions for 250 periods on AC supply ports

**Certifications - 1756 Standard AC Power Supplies**

<b>Certification<sup>(1)</sup></b>	<b>1756-PA72/C, 1756-PA75/B</b>
UL	UL Listed Industrial Control Equipment, certified for US and Canada. See UL File E65584.
CSA	CSA Certified Process Control Equipment. See CSA File LR54689C. CSA Certified Process Control Equipment for Class I, Division 2 Group A,B,C,D Hazardous Locations. See CSA File LR69960C.
CE	European Union 2004/108/IEC EMC Directive, compliant with: <ul style="list-style-type: none"> <li>• EN 61326-1; Meas./Control/Lab., Industrial Requirements</li> <li>• EN 61000-6-2; Industrial Immunity</li> <li>• EN 61000-6-4; Industrial Emissions</li> <li>• EN 61131-2; Programmable Controllers (Clause 8, Zone A &amp; B)</li> </ul> European Union 2006/95/EC LVD, compliant with: <ul style="list-style-type: none"> <li>• EN 61131-2; Programmable Controllers (Clause 11)</li> </ul>
C-Tick	Australian Radiocommunications Act, compliant with: AS/NZS CISPR 11; Industrial Emissions
FM	FM Approved Equipment for use in Class I Division 2 Group A,B,C,D Hazardous Locations
TÜV	TÜV Certified for Functional Safety: Capable of SIL 2 (1756-PA75 only)

<sup>(1)</sup> When marked. See the Product Certification link at <http://www.ab.com> for Declarations of Conformity, Certificates, and other certification details.

## Standard DC Power Supplies

### Technical Specifications - 1756 Standard DC Power Supplies

Attribute	1756-PB72/C	1756-PB75/B	1756-PC75/B	1756-PH75/B
Input voltage range	18...32V DC		30...60V DC	90...143V DC
Input voltage, nom	24V DC		48V DC	125V DC
Input power, max	95 W			
Output power, max	75 W @ 0...60 °C (32...140 °F) <sup>(1)</sup>			
Power consumption	20 W @ 0...60 °C (32...140 °F)			
Power dissipation	68.2 BTU/hr			
Hold up time <sup>(2)</sup>	35 ms @ 18V DC 40 ms @ 24V DC 40 ms @ 32V DC		50 ms @ 30...60V DC nom	50 ms @ 90...143V DC nom
Inrush current, max	30 A		20 A	
Current capacity at 1.2V	1.5 A			
Current capacity at 3.3V	4 A			
Current capacity at 5.1V	10 A	13 A		
Current capacity at 24V	2.8 A			
Overcurrent protection, max	User-supplied 15 A <sup>(3)</sup>			
Fusing	Non-replaceable fuse is soldered in place <sup>(4)</sup>			
Isolation voltage	250V (continuous), reinforced insulation type Type tested @ 3500V DC for 60 s, power input-to-backplane			
Weight, approx.	0.95 kg (2.10 lb)			
Dimensions	140 x 112 x 145 mm (5.51 x 4.41 x 5.71 in.)			
Module location	Left side of 1756 chassis			
Chassis	1756-A4, 1756-A7, 1756-A10, 1756-A13, 1756-A17			
Chassis compatibility	Series A Series B	Series B		
Wire category	1 - on power ports <sup>(5)</sup>			
Conductor screw torque	0.8 N•m (7 lb•in)			
North American temperature code	T4			
IEC temperature code	T4		—	
Enclosure type rating	None (open-style)			

<sup>(1)</sup> The combination of all output power (5.1V backplane, 24V backplane, 3.3V backplane, and 1.2V backplane) cannot exceed 75 W.

<sup>(2)</sup> The hold up time is the time between input voltage removal and DC power failure.

<sup>(3)</sup> Use time-delay type overcurrent protection in all ungrounded conductors.

<sup>(4)</sup> This fuse is intended to guard against fire hazard due to short circuit conditions.

<sup>(5)</sup> Use this conductor category information for planning conductor routing as described in the system level installation manual. See the Industrial Automation Wiring and Grounding Guidelines, publication [1770-4.1](#).

**Environmental Specifications - 1756 Standard DC Power Supplies**

Attribute	1756-PB72, 1756-PB75	1756-PC75, 1756-PH75
Temperature, operating IEC 60068-2-1 (Test Ad, Operating Cold), IEC 60068-2-2 (Test Bd, Operating Dry Heat), IEC 60068-2-14 (Test Nb, Operating Thermal Shock)	0...60 °C (32...140 °F)	
Temperature, storage IEC 60068-2-1 (Test Ab, Unpackaged Nonoperating Cold), IEC 60068-2-2 (Test Bb, Unpackaged Nonoperating Dry Heat), IEC 60068-2-14 (Test Na, Unpackaged Nonoperating Thermal Shock)	-40...85 °C (-40...185 °F)	
Relative humidity IEC 60068-2-30 (Test Db, Unpackaged Nonoperating Damp Heat)	5...95% noncondensing	
Vibration IEC 60068-2-6 (Test Fc, Operating)	2 g @ 10...500 Hz	
Shock, operating IEC 60068-2-27 (Test Ea, Unpackaged Shock)	30 g	
Shock, nonoperating IEC 60068-2-27 (Test Ea, Unpackaged Shock)	50 g	
Emissions	CISPR 11: Group 1, Class A	
ESD immunity IEC 61000-4-2	6kV contact discharges 8kV air discharges	
Radiated RF immunity IEC 61000-4-3	10V/m with 1 kHz sine-wave 80% AM from 80...2000 MHz 10V/m with 200 Hz 50% Pulse 100% AM @ 900 MHz 10V/m with 200 Hz 50% Pulse 100% AM @ 1890 MHz 3V/m with 1 kHz sine-wave 80% AM from 2000...2700 MHz	10V/m with 1 kHz sine-wave 80% AM from 80...2000 MHz 10V/m with 200 Hz 50% Pulse 100% AM @ 900 MHz 10V/m with 200 Hz 50% Pulse 100% AM @ 1890 MHz 1V/m with 1 kHz sine-wave 80% AM from 2000...2700 MHz
EFT/B immunity IEC 61000-4-4	±4 kV at 5 kHz on signal ports	
Surge transient immunity IEC 61000-4-5	±1 kV line-line (DM) and ±2 kV line-earth (CM) on signal ports	
Conducted RF immunity IEC 61000-4-6	10Vrms with 1 kHz sine-wave 80% AM from 150 kHz...80 MHz	
Oscillatory surge withstand IEEE C37.90.1	—	3 kV
Voltage variation IEC 61000-4-1	60% dips for 100 ms on DC supply ports 100% dips for 50 ms on DC supply ports ±20% fluctuations for 15 min on DC supply ports 5 s interruptions on DC supply ports	
IEC 61000-4-29	10 ms interruption on DC supply ports	

**Certifications - 1756 Standard DC Power Supplies**

Certification <sup>(1)</sup>	1756-PB72, 1756-PB75	1756-PC75, 1756-PH75
c-UL-us	UL Listed Industrial Control Equipment, certified for US and Canada. See UL File E65584.  UL Listed for Class I, Division 2 Group A,B,C,D Hazardous Locations, certified for US and Canada. See UL File E194810.	—
UL	—	UL Listed Industrial Control Equipment, certified for US and Canada. See UL File E65584.
CSA	CSA Certified Process Control Equipment. See CSA File LR54689C.  CSA Certified Process Control Equipment for Class I, Division 2 Group A,B,C,D Hazardous Locations. See CSA File LR69960C.	

**Certifications - 1756 Standard DC Power Supplies**

CE	European Union 2004/108/IEC EMC Directive, compliant with: <ul style="list-style-type: none"> <li>• EN 61326-1; Meas./Control/Lab., Industrial Requirements</li> <li>• EN 61000-6-2; Industrial Immunity</li> <li>• EN 61000-6-4; Industrial Emissions</li> <li>• EN 61131-2; Programmable Controllers (Clause 8, Zone A &amp; B)</li> </ul> European Union 2006/95/EC LVD, compliant with: <ul style="list-style-type: none"> <li>• EN 61131-2; Programmable Controllers (Clause 11)</li> </ul>	
C-Tick	Australian Radiocommunications Act, compliant with: AS/NZS CISPR 11; Industrial Emissions	
Ex	European Union 94/9/EC ATEX Directive, compliant with: <ul style="list-style-type: none"> <li>• EN 60079-15; Potentially Explosive Atmospheres, Protection "n"</li> <li>• EN 60079-0; General Requirements II 3 G Ex nA IIC T4 X</li> </ul>	—
FM	FM Approved Equipment for use in Class I Division 2 Group A,B,C,D Hazardous Locations	—
TÜV	TÜV Certified for Functional Safety: Capable of SIL 2 (1756-PB75 only)	TÜV Certified for Functional Safety: Capable of SIL 2

<sup>(1)</sup> When marked. See the Product Certification link at <http://www.ab.com> for Declarations of Conformity, Certificates, and other certification details.

**Standard Power Load and Transformer Sizing**

Use these graphs to determine the input power requirements for the supplies, given the power they are providing to the modules in the chassis. The vertical axis of each graph shows the backplane power consumed by all of the modules in the chassis; the horizontal axis shows input power requirements of the power supply. Follow these steps to use the graphs.

1. Add all of the backplane power (watts) for all of the modules in the chassis.
2. Find the number from step 1 on the vertical axis.
3. Follow that value to the right until it intersects the line on the graph.
4. Find the associated input power rating consumed by the power supply on the horizontal axis.

For example, if the power consumption of all of the modules in the chassis is 30 watts, a 1756-PB75/B power supply consumes approximately 40 watts of Real Power.



**1756-PA72/C**  
**1756-PA75/B**  
**AC**

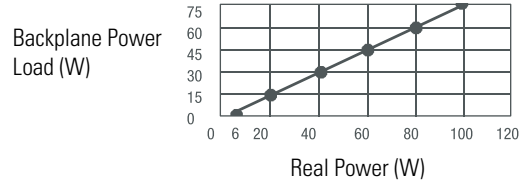

**1756-PA75R**  
**AC**

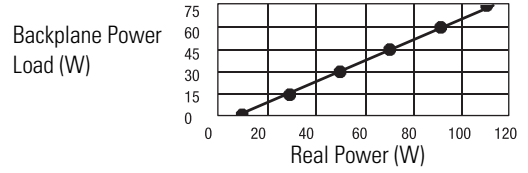

**1756-PB72/C**  
**1756-PB75/B**  
**DC**

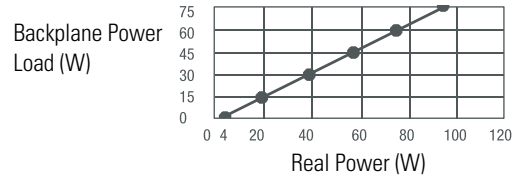

**1756-PB75R**  
**DC**

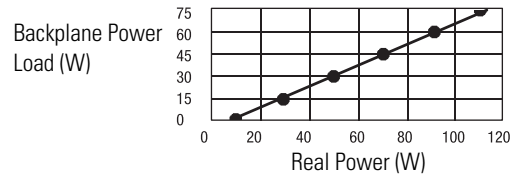

**1756-PC75**  
**1756-PH75**  
**DC**

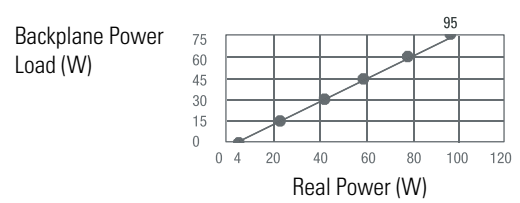

## Redundant Power Supplies

To build a redundant power supply system, you need:

- two redundant power supplies (both 1756-PA75R or 1756-PB75R).
- one 1756-PSCA2 chassis adapter module.
- two 1756-CPR2 cables to connect the power supplies to the 1756-PSCA2 chassis adapter module (0.91 m (3 ft) length).
- user-supplied annunciator wiring to connect the power supplies to the input modules, as needed.

The 1756-PSCA2 chassis adapter module is a passive device that funnels power from the redundant power supplies to the single power connector on the ControlLogix series B chassis backplane.

### Recommended Configuration for One Chassis

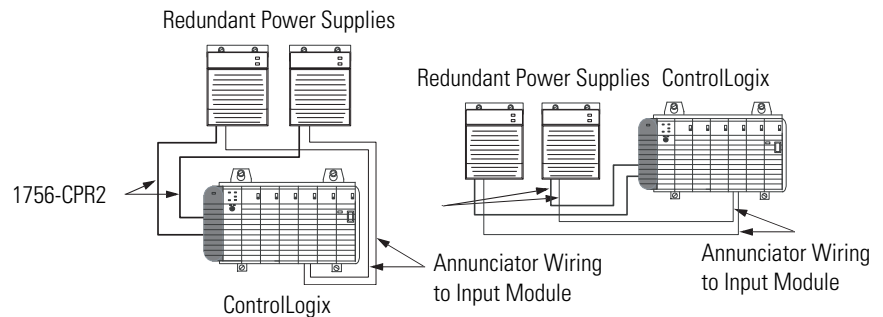

### Recommended Configuration for Two Chassis

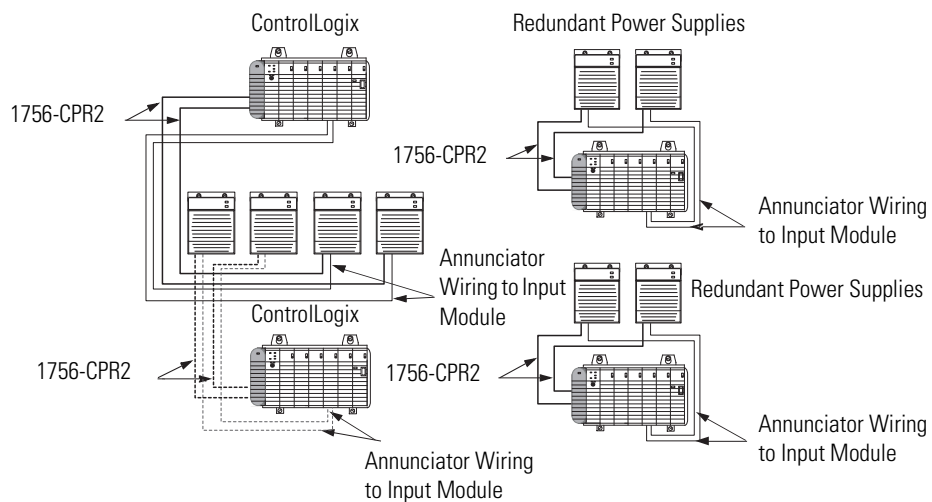

## 1756-PA75R and 1756-PB75R Mounting Dimensions

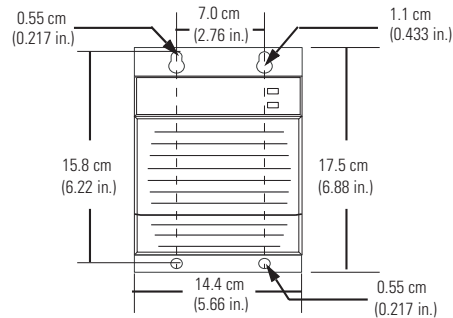

## Redundant Power Supply Features

The redundant power supplies offer the same features as the standard power supplies, in addition to:

- automatic chassis load sharing between the redundant power supplies.
- status indicators for visual operating status of the pair.
- solid state relay for system recognition of supply status when wired to an input module.

### Technical Specifications - 1756 Redundant Power Supplies

Attribute	1756-PA75R	1756-PB75R
Input voltage range	85...265V AC	19.2...32V DC
Input voltage	120V/220V AC	24V DC
Input frequency range	47...63 Hz	DC
Input power, max	120VA 115 W	110 W
Output power, max	75 W @ 60 °C (140 °F)	
Hold up time‡	2 cycles @ 60 Hz 2 cycles @ 50 Hz	20 ms
Inrush current, max	20 A	30 A
Current capacity at 1.2V	1.5 A	
Current capacity at 3.3V	4 A	
Current capacity at 5.1V	13 A	
Current capacity at 5.1V	2.8 A	
Overcurrent protection, max	User-supplied 15 A <sup>(1)</sup>	
Fusing	Non-replaceable fuse is soldered in place <sup>(2)</sup>	
Isolation voltage	250V (continuous), input-to-input and status contact to input or output	
Dimensions (HxWxD), approx.	175 x 145 x 137 mm (6.9 x 5.7 x 5.4 in.)	
Weight, approx.	1.45 kg (3.2 lb)	
Chassis	1756-A4, 1756-A7, 1756-A10, 1756-A13, 1756-A17	

**Technical Specifications - 1756 Redundant Power Supplies**

Attribute	1756-PA75R	1756-PB75R
Annunciator wire size	0.324 ... 2.08 mm <sup>2</sup> (22 ... 14 AWG) stranded 75 °C (167 °F) copper	
Annunciator wire category	3 <sup>(3)</sup>	
Conductor wire size	2.08 mm <sup>2</sup> (14 AWG) stranded	
Conductor wire category	1 <sup>(3)</sup>	
Wire type	Copper	
Conductor screw torque	0.79 N•m (7 lb•in)	
Solid state relay contact	265V AC/DC <sup>(4)</sup>	240V AC/DC <sup>(2)</sup>
Enclosure type rating	None (open-style)	

(1) Use time-delay type overcurrent protection in all ungrounded conductors.

(2) This fuse is intended to guard against fire hazard due to short circuit conditions.

(3) Use this conductor category information for planning conductor routing as described in the system level installation manual. See the Industrial Automation Wiring and Grounding Guidelines, publication [1770-4.1](#).

(4) Do not exceed 50 mA; resistive only. The hold up time is the time between input voltage removal and DC power failure.

**Environmental Specifications - 1756 Redundant Power Supplies**

Attribute	1756-PA75R	1756-PB75R
Temperature, operating IEC 60068-2-1 (Test Ad, Operating Cold), IEC 60068-2-2 (Test Bd, Operating Dry Heat), IEC 60068-2-14 (Test Nb, Operating Thermal Shock)	0 ... 60 °C (32 ... 140 °F)	
Temperature, storage IEC 60068-2-1 (Test Ab, Unpackaged Nonoperating Cold), IEC 60068-2-2 (Test Bb, Unpackaged Nonoperating Dry Heat), IEC 60068-2-14 (Test Na, Unpackaged Nonoperating Thermal Shock)	-40 ... 85 °C (-40 ... 185 °F)	
Relative humidity IEC 60068-2-30 (Test Db, Unpackaged Nonoperating Damp Heat)	5 ... 95% noncondensing	
Vibration IEC 60068-2-6 (Test Fc, Operating)	2 g @ 10 ... 500 Hz	
Shock, operating IEC 60068-2-27 (Test Ea, Unpackaged Shock)	30 g	
Shock, nonoperating IEC 60068-2-27 (Test Ea, Unpackaged Shock)	50 g	
Emissions	CISPR 11: Group 1, Class A	
ESD immunity IEC 61000-4-2	6 kV contact discharges 8 kV air discharges	
Radiated RF immunity IEC 61000-4-3	10V/m with 1 kHz sine-wave 80% AM from 30 ... 1000 MHz 10V/m with 200 Hz 50% Pulse 100% AM @ 900 MHz	
EFT/B immunity IEC 61000-4-4	±4 kV at 5 kHz on signal ports	

**Environmental Specifications - 1756 Redundant Power Supplies**

Attribute	1756-PA75R	1756-PB75R
Surge transient immunity IEC 61000-4-5	±1 kV line-line (DM) and ±2 kV line-earth (CM) on signal ports	
Conducted RF immunity IEC 61000-4-6	10Vrms with 1 kHz sine-wave 80% AM from 150 kHz...80 MHz	
Voltage variation IEC 61000-4-1	30% dips for 1 period at 0° and 180° on AC supply ports 60% dips for 5 and 50 periods on AC supply ports ±10% fluctuations for 15 min on AC supply ports >95% interruptions for 250 periods on AC supply ports	60% dips for 100 ms on DC supply ports 100% dips for 50 ms on DC supply ports ±20% fluctuations for 15 min on DC supply ports 5 s interruptions on DC supply ports

**Certifications - 1756 Redundant Power Supplies**

Certification <sup>(1)</sup>	1756-PA75R	1756-PB75R
UL	UL Listed Industrial Control Equipment.	
c-UL-us	UL Listed for Class I, Division 2 Group A,B,C,D Hazardous Locations, certified for U.S. and Canada.	
CSA	CSA Certified Process Control Equipment. CSA Certified Process Control Equipment for Class I, Division 2 Group A,B,C,D Hazardous Locations.	
CE	European Union 89/336/EEC EMC Directive, compliant with: <ul style="list-style-type: none"> <li>EN 50082-2; Industrial Immunity</li> <li>EN 61326; Meas./Control/Lab., Industrial Requirements</li> <li>EN 61000-6-2; Industrial Immunity</li> <li>EN 61000-6-4; Industrial Emissions</li> </ul> European Union 73/23/EEC LVD Directive, compliant with: <ul style="list-style-type: none"> <li>EN 61131-2; Programmable Controllers</li> </ul>	European Union 89/336/EEC EMC Directive, compliant with: <ul style="list-style-type: none"> <li>EN 50082-2; Industrial Immunity</li> <li>EN 61326; Meas./Control/Lab., Industrial Requirements</li> <li>EN 61000-6-2; Industrial Immunity</li> <li>EN 61000-6-4; Industrial Emissions</li> </ul>
C-Tick	Australian Radiocommunications Act, compliant with: AS/NZS CISPR 11; Industrial Emissions	
Ex	European Union 94/9/EC ATEX Directive, compliant with: <ul style="list-style-type: none"> <li>EN 50021; Potentially Explosive Atmospheres, Protection "n" (Zone 2)</li> </ul>	—
FM	FM Approved Equipment for use in Class I Division 2 Group A,B,C,D Hazardous Locations	

<sup>(1)</sup> When marked. See the Product Certification link at <http://www.ab.com> for Declarations of Conformity, Certificates, and other certification details.

**Accessories - 1756 Redundant Power Supplies**

Cat. No.	Description	Specifications
1756-PSCA2	Chassis adapter module. Funnel power from the redundant power supplies to the single power connector on the ControlLogix series B chassis backplane.	Mounts directly to left side of 1756 chassis
1756-CPR2	Chassis adapter cable. Connects redundant power supply to 1756-PSCA2 chassis adapter.	Length: 0.91 m (3 ft)

## Redundant Power Load and Transformer Sizing

### 1756-PA75R/A AC

Backplane Power  
Load (W)

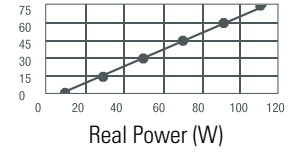
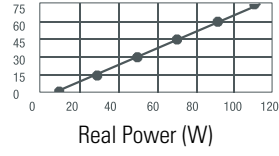

### 1756-PB75R/A DC

Backplane Power  
Load (W)

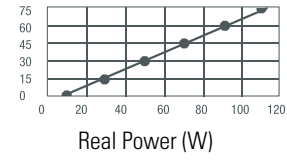

## 1756 ControlLogix-XT Power Supplies

The ControlLogix-XT products include control and communication system components that, when used with FLEX I/O-XT products, provide a complete control system solution that can be used in environments where temperatures range from -20...70 °C (-4...158 °F).

When used independently, the ControlLogix-XT system can withstand environments where the temperature ranges from -25...70 °C (-13...158 °F).

### Technical Specifications - 1756 XT Power Supplies

Attribute	1756-PAXT	1756-PBXT
Input voltage range	85...265V AC	18...32V DC
Input voltage, nom	120/240V AC	24V DC
Input frequency range	50/60 Hz	DC
Input power, max	82VA 64 W	54 W
Output power, max	42 W @ -25...70 °C (-13...158 °F)	
Power consumption	22 W	12 W
Power dissipation	75.1 BTU/hr	40.9 BTU/hr
Hold up time <sup>(1)</sup>	6 cycles @ 85V AV, 50/60 Hz 6 cycles @ 120V AV, 50/60 Hz 6 cycles @ 200V AV, 50/60 Hz 6 cycles @ 240V AV, 50/60 Hz	35 ms @ 18V DC 40 ms @ 24V DC 40 ms @ 32V DC
Inrush current, max	20 A	30 A
Current capacity at 1.2V	1.5 A	
Current capacity at 3.3V	4 A	
Current capacity at 5.1V	8 A	
Current capacity at 24V	1.75 A	
User-supplied overcurrent protection, max	15 A <sup>(2)</sup>	
Fusing	Non-replaceable fuse is soldered in place <sup>(3)</sup>	
Isolation voltage	250V (continuous), reinforced insulation type Type tested @ 3500V DC for 60 s, power input-to-backplane	
Weight, approx.	0.95 kg (2.10 lb)	
Dimensions	140 x 112 x 145 mm (5.51 x 4.41 x 5.71 in.)	
Module location	Left side of 1756 chassis	
Chassis	1756-A4XT, 1756-A5XT, 1756-A7XLT	
Wire category	1 - on power ports <sup>(4)</sup>	
Wire size	2.5 mm <sup>2</sup> (14 AWG) solid or stranded copper wire rated at 75 °C (167 °F), or greater, 1.2 mm (3/64 in.) insulation max	
Conductor screw torque	0.8 N•m (7 lb•in)	0.8 N•m (7 lb•in)
North American temperature code	T4	T4A
IEC temperature code	T4	
Enclosure type rating	None (open-style)	None (open-style)

<sup>(1)</sup> The hold up time is the time between input voltage removal and DC power failure.

<sup>(2)</sup> Use time-delay type overcurrent protection in all ungrounded conductors.

<sup>(3)</sup> This fuse is intended to guard against fire hazard due to short circuit conditions.

<sup>(4)</sup> Use this conductor category information for planning conductor routing as described in the system level installation manual. See the Industrial Automation Wiring and Grounding Guidelines, publication [1770-4.1](#).

**Environmental Specifications - 1756 XT Power Supplies**

Attribute	1756-PAXT	1756-PBXT
Temperature, operating IEC 60068-2-1 (Test Ad, Operating Cold), IEC 60068-2-2 (Test Bd, Operating Dry Heat), IEC 60068-2-14 (Test Nb, Operating Thermal Shock)	-25...70 °C (-13...158 °F)	
Temperature, storage IEC 60068-2-1 (Test Ab, Unpackaged Nonoperating Cold), IEC 60068-2-2 (Test Bb, Unpackaged Nonoperating Dry Heat), IEC 60068-2-14 (Test Na, Unpackaged Nonoperating Thermal Shock)	-40...85 °C (-40...185 °F)	
Relative humidity IEC 60068-2-30 (Test Db, Unpackaged Nonoperating Damp Heat)	5...95% noncondensing	
Vibration IEC 60068-2-6 (Test Fc, Operating)	2 g @ 10...500 Hz	
Shock, operating IEC 60068-2-27 (Test Ea, Unpackaged Shock)	30 g	
Shock, nonoperating IEC 60068-2-27 (Test Ea, Unpackaged Shock)	50 g	
Emissions	CISPR 11: Group 1, Class A	
ESD immunity IEC 61000-4-2	6 kV contact discharges 8 kV air discharges	
Radiated RF immunity IEC 61000-4-3	10V/m with 1 kHz sine-wave 80% AM from 80...2000 MHz 10V/m with 200 Hz 50% Pulse 100% AM at 900 MHz 10V/m with 200 Hz 50% Pulse 100% AM at 1890 MHz 3V/m with 1 kHz sine-wave 80% AM from 2000...2700 MHz	
EFT/B immunity IEC 61000-4-4	±4kV at 5kHz on signal ports	
Surge transient immunity IEC 61000-4-5	±1 kV line-line (DM) and ±2 kV line-earth (CM) on signal ports	
Conducted RF immunity IEC 61000-4-6	10Vrms with 1 kHz sine-wave 80% AM from 150 kHz...80 MHz	
Voltage variation IEC 61000-4-1	30% dips for 1 period at 0° and 180° on AC supply ports 60% dips for 5 and 50 periods on AC supply ports ±10% fluctuations for 15 min on AC supply ports >95% interruptions for 250 periods on AC supply ports	60% dips for 100 ms on DC supply ports 100% dips for 50 ms on DC supply ports ±20% fluctuations for 15 min on DC supply ports 5 s interruptions on DC supply ports
Voltage variation IEC 61000-4-29	—	10 ms interruption on DC supply ports
Oscillatory surge withstand IEEE C37.90.1	3 kV	—



**Certifications - 1756 XT Power Supplies**

<b>Certification<sup>(1)</sup></b>	<b>1756-PA75R, 1756-PB75R</b>
c-UL-us	UL Listed Industrial Control Equipment, certified for US and Canada. See UL File E65584. UL Listed for Class 1, Division 2 Group A,B,C,D Hazardous Locations, certified for US and Canada. See UL File E194810.
CE	European Union 2004/108/IEC EMC Directive, compliant with: <ul style="list-style-type: none"> <li>• EN 61326-1; Meas./Control/Lab., Industrial Requirements</li> <li>• EN 61000-6-2; Industrial Immunity</li> <li>• EN 61000-6-4; Industrial Emissions</li> <li>• EN 61131-2; Programmable Controllers (Clause 8, Zone A &amp; B)</li> </ul> European Union 2006/95/EC LVD, compliant with: <ul style="list-style-type: none"> <li>• EN 61131-2; Programmable Controllers (Clause 11)</li> </ul>
C-Tick	Australian Radiocommunications Act, compliant with: AS/NZS CISPR 11; Industrial Emissions
Ex	European Union 94/9/EC ATEX Directive, compliant with: <ul style="list-style-type: none"> <li>• EN 60079-15; Potentially Explosive Atmospheres, Protection "n"</li> <li>• EN 60079-0; General Requirements II 3 G Ex nA IIC T4 X</li> </ul>
TÜV	TÜV Certified for Functional Safety: Capable of SIL 2

<sup>(1)</sup> When marked. See the Product Certification link at <http://www.ab.com> for Declarations of Conformity, Certificates, and other certification details.

# Rockwell Automation Support

Rockwell Automation provides technical information on the Web to assist you in using its products. At <http://www.rockwellautomation.com/support/>, you can find technical manuals, a knowledge base of FAQs, technical and application notes, sample code and links to software service packs, and a MySupport feature that you can customize to make the best use of these tools.

For an additional level of technical phone support for installation, configuration, and troubleshooting, we offer TechConnect support programs. For more information, contact your local distributor or Rockwell Automation representative, or visit <http://www.rockwellautomation.com/support/>.

## Installation Assistance

If you experience an anomaly within the first 24 hours of installation, review the information that is contained in this manual. You can contact Customer Support for initial help in getting your product up and running.

United States or Canada	1.440.646.3434
Outside United States or Canada	Use the <a href="#">Worldwide Locator</a> at <a href="http://www.rockwellautomation.com/support/americas/phone_en.html">http://www.rockwellautomation.com/support/americas/phone_en.html</a> , or contact your local Rockwell Automation representative.

## New Product Satisfaction Return

Rockwell Automation tests all of its products to ensure that they are fully operational when shipped from the manufacturing facility. However, if your product is not functioning and needs to be returned, follow these procedures.

United States	Contact your distributor. You must provide a Customer Support case number (call the phone number above to obtain one) to your distributor to complete the return process.
Outside United States	Please contact your local Rockwell Automation representative for the return procedure.

## Documentation Feedback

Your comments will help us serve your documentation needs better. If you have any suggestions on how to improve this document, complete this form, publication [RA-DU002](#), available at <http://www.rockwellautomation.com/literature/>.

**[www.rockwellautomation.com](http://www.rockwellautomation.com)**

### Power, Control and Information Solutions Headquarters

Americas: Rockwell Automation, 1201 South Second Street, Milwaukee, WI 53204-2496 USA, Tel: (1) 414.382.2000, Fax: (1) 414.382.4444

Europe/Middle East/Africa: Rockwell Automation, Vorstlaan/Boulevard du Souverain 36, 1170 Brussels, Belgium, Tel: (32) 2 663 0600, Fax: (32) 2 663 0640

Asia Pacific: Rockwell Automation, Level 14, Core F, Cyberport 3, 100 Cyberport Road, Hong Kong, Tel: (852) 2887 4788, Fax: (852) 2508 1846