

# MicroLogix 1762-IF4 Analog Input Module

Catalog Number 1762-IF4

---

[http://literature.rockwellautomation.com/idc/groups/literature/documents/in/1762-in012\\_-mu-p.pdf](http://literature.rockwellautomation.com/idc/groups/literature/documents/in/1762-in012_-mu-p.pdf)

---

**FR**

Cette publication est disponible en français sous forme électronique (fichier PDF). Pour la télécharger, rendez-vous sur la page Internet indiquée ci-dessus.

**IT**

Questa pubblicazione è disponibile in Italiano in formato PDF. Per scaricarla collegarsi al sito Web indicato sopra.

**DE**

Diese Publikation ist als PDF auf Deutsch verfügbar. Gehen Sie auf die oben genannte Web-Adresse, um nach der Publikation zu suchen und sie herunterzuladen.

**ES**

Esta publicación está disponible en español como PDF. Diríjase a la dirección web indicada arriba para buscar y descarga esta publicación.

**PT**

Esta publicação está disponível em português como PDF. Vá ao endereço web que aparece acima para encontrar e fazer download da publicação.

---



# MicroLogix 1762-IF4 Analog Input Module

Catalog Number 1762-IF4

<b>Topic</b>	<b>Page</b>
Important User Information	4
North American Hazardous Location Approval	6
Additional Resources	7
Overview	8
Module Description	9
Mount the Module	10
Field Wiring Connections	13
Input Type Selection	13
Wiring the Finger-Safe Terminal Block	17
Wire Size and Terminal Screw Torque	17
Specifications	22

## Important User Information

Solid state equipment has operational characteristics differing from those of electromechanical equipment. Safety Guidelines for the Application, Installation and Maintenance of Solid State Controls (Publication SGI-1.1 available from your local Rockwell Automation sales office or online at <http://literature.rockwellautomation.com>) describes some important differences between solid state equipment and hard-wired electromechanical devices. Because of this difference, and also because of the wide variety of uses for solid state equipment, all persons responsible for applying this equipment must satisfy themselves that each intended application of this equipment is acceptable.





In no event will Rockwell Automation, Inc. be responsible or liable for indirect or consequential damages resulting from the use or application of this equipment.

The examples and diagrams in this manual are included solely for illustrative purposes. Because of the many variables and requirements associated with any particular installation, Rockwell Automation, Inc. cannot assume responsibility or liability for actual use based on the examples and diagrams.

No patent liability is assumed by Rockwell Automation, Inc. with respect to use of information, circuits, equipment, or software described in this manual.

Reproduction of the contents of this manual, in whole or in part, without written permission of Rockwell Automation, Inc., is prohibited.

Throughout this manual, when necessary, we use notes to make you aware of safety considerations.

<p><b>WARNING</b></p> 	<p>Identifies information about practices or circumstances that can cause an explosion in a hazardous environment, which may lead to personal injury or death, property damage, or economic loss.</p>
<p><b>IMPORTANT</b></p>	<p>Identifies information that is critical for successful application and understanding of the product.</p>
<p><b>ATTENTION</b></p> 	<p>Identifies information about practices or circumstances that can lead to personal injury or death, property damage, or economic loss. Attentions help you identify a hazard, avoid a hazard and recognize the consequences.</p>
<p><b>SHOCK HAZARD</b></p> 	<p>Labels may be on or inside the equipment (for example, drive or motor) to alert people that dangerous voltage may be present.</p>
<p><b>BURN HAZARD</b></p> 	<p>Labels may be on or inside the equipment (for example, drive or motor) to alert people that surfaces may reach dangerous temperatures.</p>

---

## Environment and Enclosure

---

**ATTENTION**

This equipment is intended for use in a Pollution Degree 2 industrial environment, in overvoltage Category II applications (as defined in IEC 60664-1), at altitudes up to 2000 m (6562 ft) without derating. This equipment is considered Group 1, Class A industrial equipment according to IEC/CISPR 11. Without appropriate precautions, there may be difficulties with electromagnetic compatibility in residential and other environments due to conducted and radiated disturbances.

This equipment is supplied as open-type equipment. It must be mounted within an enclosure that is suitably designed for those specific environmental conditions that will be present and appropriately designed to prevent personal injury resulting from accessibility to live parts. The enclosure must have suitable flame-retardant properties to prevent or minimize the spread of flame, complying with a flame spread rating of 5VA, V2, V1, V0 (or equivalent) if non-metallic. The interior of the enclosure must be accessible only by the use of a tool. Subsequent sections of this publication may contain additional information regarding specific enclosure type ratings that are required to comply with certain product safety certifications.

In addition to this publication, see:

- Industrial Automation Wiring and Grounding Guidelines, for additional installation requirements, Allen-Bradley publication [1770-4.1](#).
- NEMA Standards 250 and IEC 60529, as applicable, for explanations of the degrees of protection provided by different types of enclosure.

---

## Preventing Electrostatic Discharge

---



**ATTENTION**

This equipment is sensitive to electrostatic discharge, which can cause internal damage and affect normal operation. Follow these guidelines when you handle this equipment:

- Touch a grounded object to discharge potential static.
  - Wear an approved grounding wriststrap.
  - Do not touch connectors or pins on component boards.
  - Do not touch circuit components inside the equipment.
  - Use a static-safe workstation, if available.
  - Store the equipment in appropriate static-safe packaging when not in use.
-

## North American Hazardous Location Approval

The following modules are North American Hazardous Location approved: 1762-IF4

<p><b>The following information applies when operating this equipment in hazardous locations:</b></p>	<p><b>Informations sur l'utilisation de cet équipement en environnements dangereux:</b></p>
<p>Products marked "CL I, DIV 2, GP A, B, C, D" are suitable for use in Class I Division 2 Groups A, B, C, D, Hazardous Locations and nonhazardous locations only. Each product is supplied with markings on the rating nameplate indicating the hazardous location temperature code. When combining products within a system, the most adverse temperature code (lowest "T" number) may be used to help determine the overall temperature code of the system. Combinations of equipment in your system are subject to investigation by the local Authority Having Jurisdiction at the time of installation.</p>	<p>Les produits marqués "CL I, DIV 2, GP A, B, C, D" ne conviennent qu'à une utilisation en environnements de Classe I Division 2 Groupes A, B, C, D dangereux et non dangereux. Chaque produit est livré avec des marquages sur sa plaque d'identification qui indiquent le code de température pour les environnements dangereux. Lorsque plusieurs produits sont combinés dans un système, le code de température le plus défavorable (code de température le plus faible) peut être utilisé pour déterminer le code de température global du système. Les combinaisons d'équipements dans le système sont sujettes à inspection par les autorités locales qualifiées au moment de l'installation.</p>
<p><b>WARNING</b></p> 	<p><b>EXPLOSION HAZARD</b></p> <ul style="list-style-type: none"> <li>Do not disconnect equipment unless power has been removed or the area is known to be nonhazardous.</li> <li>Do not disconnect connections to this equipment unless power has been removed or the area is known to be nonhazardous. Secure any external connections that mate to this equipment by using screws, sliding latches, threaded connectors, or other means provided with this product.</li> <li>Substitution of any component may impair suitability for Class I, Division 2.</li> <li>If this product contains batteries, they must only be changed in an area known to be nonhazardous.</li> </ul>
<p><b>AVERTISSEMENT</b></p> 	<p><b>RISQUE D'EXPLOSION</b></p> <ul style="list-style-type: none"> <li>Couper le courant ou s'assurer que l'environnement est classé non dangereux avant de débrancher l'équipement.</li> <li>Couper le courant ou s'assurer que l'environnement est classé non dangereux avant de débrancher les connecteurs. Fixer tous les connecteurs externes reliés à cet équipement à l'aide de vis, loquets coulissants, connecteurs filetés ou autres moyens fournis avec ce produit.</li> <li>La substitution de tout composant peut rendre cet équipement inadapté à une utilisation en environnement de Classe I, Division 2.</li> <li>S'assurer que l'environnement est classé non dangereux avant de changer les piles.</li> </ul>

## Additional Resources

Resource	Description
MicroLogix 1100 Programmable Controllers User Manual, publication <a href="#">1763-UM001</a>	A more detailed description of how to install and use your MicroLogix 1100 programmable controller and expansion I/O system.
MicroLogix 1200 Programmable Controllers User Manual, publication <a href="#">1762-UM001</a>	A more detailed description of how to install and use your MicroLogix 1200 programmable controller and expansion I/O system.
MicroLogix 1400 Programmable Controllers User Manual, publication <a href="#">1766-UM001</a>	A more detailed description of how to install and use your MicroLogix 1400 programmable controller and expansion I/O system.
MicroLogix 1100 Programmable Controllers Installation Instructions, publication <a href="#">1763-IN001</a>	Information on installing and using the MicroLogix 1100 programmable controller.
MicroLogix 1200 Programmable Controllers Installation Instructions, publication <a href="#">1762-IN006</a>	Information on installing and using the MicroLogix 1200 programmable controller.
MicroLogix 1400 Programmable Controllers Installation Instructions, publication <a href="#">1766-IN001</a>	Information on installing and using the MicroLogix 1400 programmable controller.
Industrial Automation Wiring and Grounding Guidelines, publication <a href="#">1770-4.1</a>	More information on proper wiring and grounding techniques.

If you would like a manual, you can:

- download a free electronic version from the Internet:  
<http://literature.rockwellautomation.com>
- purchase a printed manual by contacting your local Allen-Bradley distributor or Rockwell Automation representative

## Overview

1762 input module is suitable for use in an industrial environment when installed in accordance with these instructions. Specifically, this equipment is intended for use in clean, dry environments (Pollution degree 2<sup>(1)</sup>) and to circuits not exceeding Over Voltage Category II<sup>(2)</sup> (IEC 60664-1)<sup>(3)</sup>.

Install your module using these installation instructions.

### 1762 Input Module

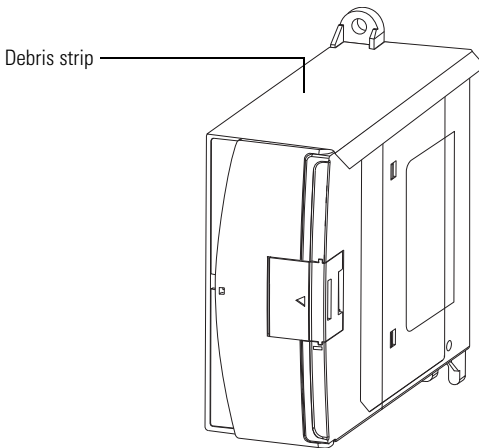

45155

---

#### ATTENTION



Do not remove the protective debris strip until after the module and all other equipment in the panel near the module are mounted and wiring is complete. Once wiring is complete, remove protective debris strip. Failure to remove strip before operating can cause overheating.

---

#### ATTENTION



Electrostatic discharge can damage semiconductor devices inside the module. Do not touch the connector pins or other sensitive areas.

- 
- (1) Pollution Degree 2 is an environment where, normally, only non-conductive pollution occurs except that occasionally a temporary conductivity caused by condensation shall be expected.
- (2) Over Voltage Category II is the load level section of the electrical distribution system. At this level transient voltages are controlled and do not exceed the impulse voltage capability of the product's insulation.
- (3) Pollution Degree 2 and Over Voltage Category II are International Electrotechnical Commission (IEC) designations.



## Module Description

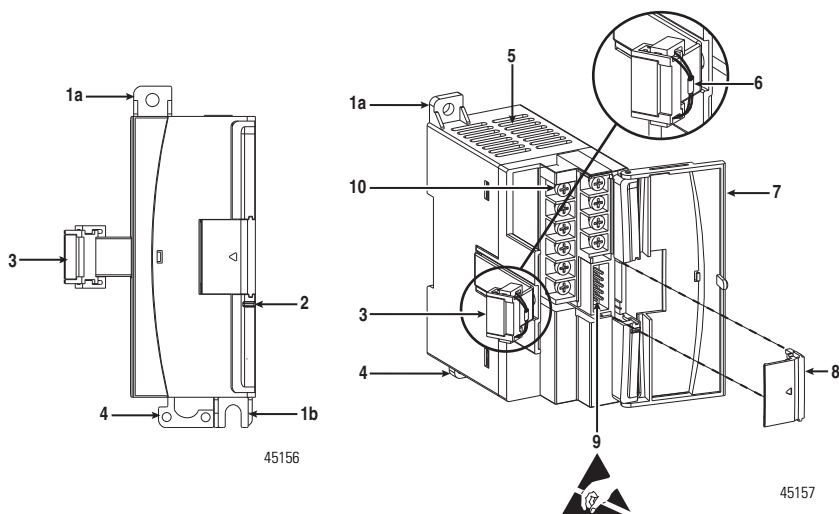

This equipment is sensitive to electrostatic discharge (ESD).  
Follow ESD prevention guidelines when handling this equipment.

**Front view**

**Left side view**

	<b>Description</b>		<b>Description</b>
1a	upper panel mounting tab	5	input type selector switch
1b	lower panel mounting tab	6	pull loop
2	power diagnostic LED	7	module door with terminal identification label
3	flat ribbon cable with bus connector (female)	8	bus connector cover
4	DIN rail latch	9	bus connector with male pins
		10	terminal block

### ATTENTION



To comply with UL restrictions, this equipment must be powered from a source compliant with Class 2 or Limited Voltage/Current.

## Mount the Module

### General Considerations

Most applications require installation in an industrial enclosure to reduce the effects of electrical interference and environmental exposure. Locate your controller as far as possible from power lines, load lines, and other sources of electrical noise such as hard-contact switches, relays, and AC motor drives. For more information on proper grounding guidelines, see the Industrial Automation Wiring and Grounding Guidelines, publication [1770-4.1](#).

#### ATTENTION



This product is intended to be mounted to a well-grounded mounting surface such as a metal panel. Additional grounding connections from the power supply's mounting tabs or DIN rail (if used) are not required unless the mounting surface cannot be grounded. Refer to Industrial Automation Wiring and Grounding Guidelines, Allen-Bradley publication [1770-4.1](#), for additional information.

---

### Mounting Dimensions

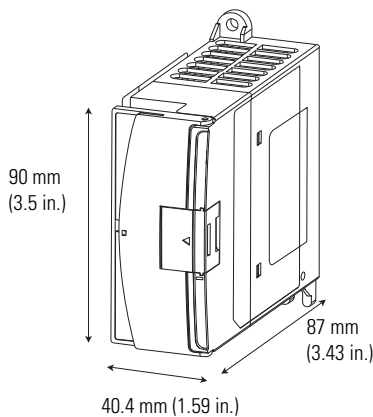

45158

Measurements do not include mounting feet or DIN rail latches.

## Module Spacing

Maintain spacing from objects such as enclosure walls, wireways and adjacent equipment. Allow 50.8 mm (2 in.) of space on all sides for adequate ventilation, as shown:

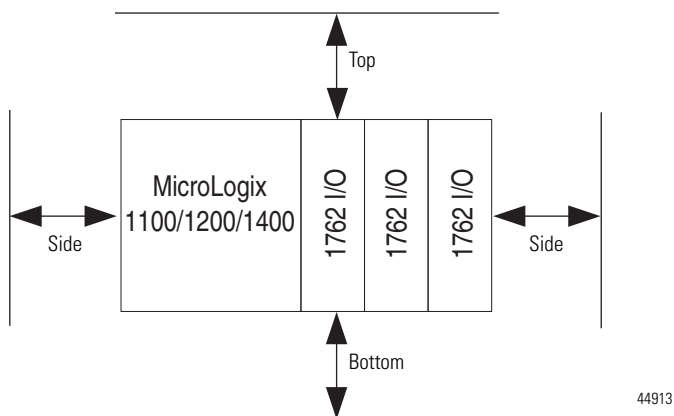

## DIN Rail Mounting

The module can be mounted using the following DIN rails: 35 x 7.5 mm (EN 50 022 - 35 x 7.5) or 35 x 15 mm (EN 50 022 - 35 x 15).

Before mounting the module on a DIN rail, close the DIN rail latch. Press the DIN rail mounting area of the module against the DIN rail. The latch will momentarily open and lock into place.

Use DIN rail end anchors (Allen-Bradley part number 1492-EA35 or 1492-EAH35) for vibration or shock environments.

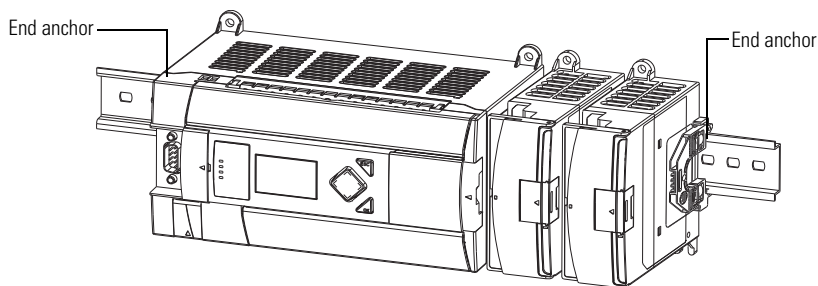

45159

### TIP

For environments with greater vibration and shock concerns, use the panel mounting method described below, instead of DIN rail mounting.

## Panel Mounting

Use the dimensional template shown below to mount the module. The preferred mounting method is to use two M4 (#8) panhead screws per module. M3.5 (#6) panhead screws may also be used, but a washer may be needed to ensure a good mechanical contact. Mounting screws are required on every module.

For more than 2 I/O modules: measure (number of modules - 1) x 40 mm (1.59 in.)

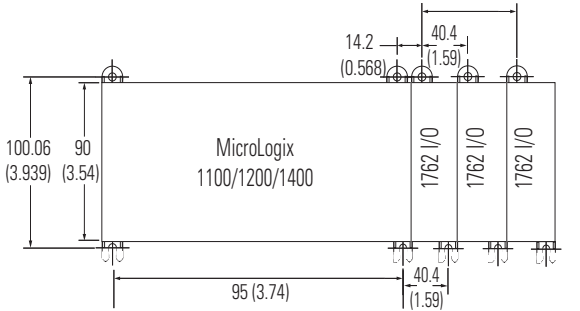

44914

**NOTE:** All dimensions are in mm (in.). Hole spacing tolerance:  $\pm 0.4$  mm (0.016 in.).

## System Assembly

The expansion I/O module is attached to the controller or another I/O module by means of a flat ribbon cable *after* mounting as shown below.

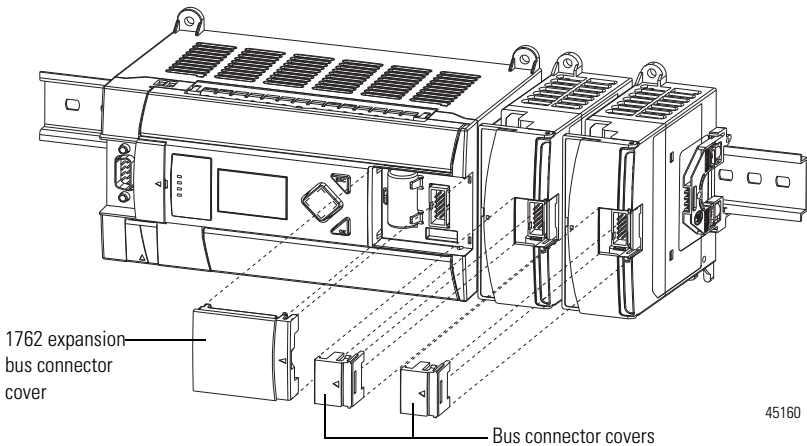

**TIP**

Use the pull loop on the connector to disconnect modules. Do not pull on the ribbon cable.

---

## Field Wiring Connections

### Grounding the Module

In solid-state control systems, grounding and wire routing helps limit the effects of noise due to electromagnetic interference (EMI). Run the ground connection from the ground screw of the controller to the ground bus prior to connecting any devices. Use AWG #14 wire. For AC-powered controllers, this connection must be made for safety purposes.

You must also provide an acceptable grounding path for each device in your application. For more information on proper grounding guidelines, refer to the Industrial Automation Wiring and Grounding Guidelines, publication [1770-4.1](#).

---

**WARNING****EXPLOSION HAZARD**

- In Class I, Division 2 applications, the bus connector must be fully seated and the bus connector cover must be snapped in place.
- In Class I, Division 2 applications, all modules must be mounted in direct contact with each other as shown on page 12. If DIN rail mounting is used, an end anchor must be installed ahead of the controller and after the last 1762 I/O module.

---

**ATTENTION**

To comply with the CE Low Voltage Directive (LVD), all connected I/O must be powered from a source compliant with the Safety Extra Low Voltage (SELV) or Protected Extra Low Voltage (PELV).

---

**WARNING**

If you connect or disconnect wiring while the field-side power is on, an electrical arc can occur. This could cause an explosion in hazardous location installations. Be sure that power is removed or the area is nonhazardous before proceeding.

---

### Input Type Selection

Select the input type, current or voltage, using the switch located on the module's circuit board *and* the input type/range selection bits in the Configuration Data File (see page 19). You can access the switch through the ventilation slots on the top of

the module. The factory default setting for all switches is Current. Switch positions are shown below.

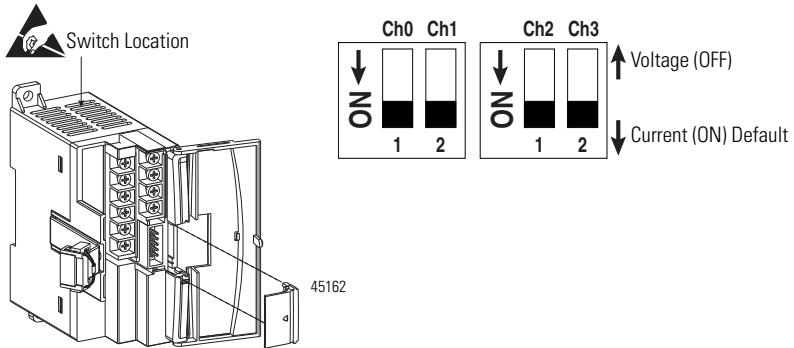

## Input Wiring

Basic wiring of input devices to the 1762-IF4 is shown below.

## Terminal Block Layout

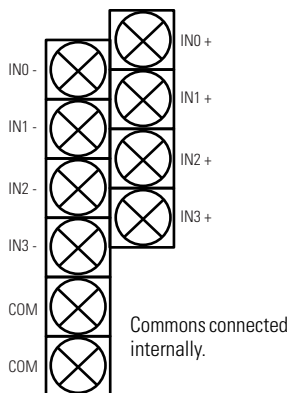

## Basic Input Wiring to the 1762-IF4 Module

### Differential Sensor Transmitter Types

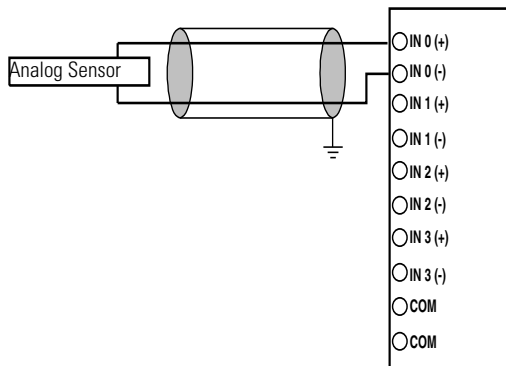

#### TIP

Grounding the cable shield at the module end only usually provides sufficient noise immunity. However, for best cable shield performance, earth ground the shield at both ends, using a 0.01  $\mu\text{F}$  capacitor at one end to block AC power ground currents, if necessary.

## Sensor/Transmitter Types

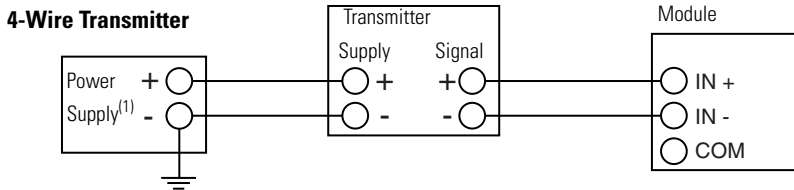
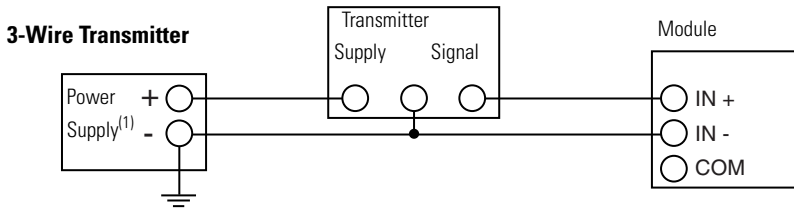
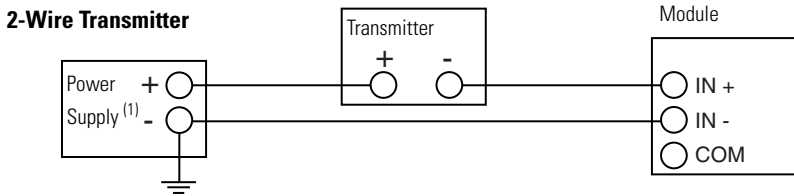

(1) All power supplies rated N.E.C. Class 2.



## Wiring the Finger-Safe Terminal Block

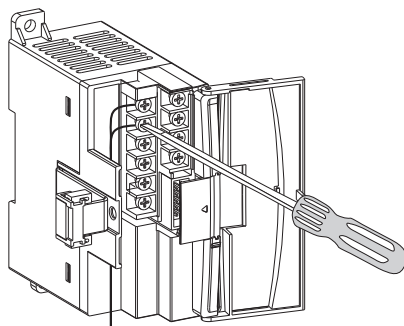

### ATTENTION



Be careful when stripping wires. Wire fragments that fall into a module could cause damage when power is applied. Once wiring is complete, ensure the module is free of all metal fragments.

When wiring the terminal block, keep the finger-safe cover in place.

1. Route the wire under the terminal pressure plate. You can use the stripped end of the wire or a spade lug. The terminals will accept a 6.35 mm (0.25 in.) spade lug.
2. Tighten the terminal screw making sure the pressure plate secures the wire. Recommended torque when tightening terminal screws is 0.904 Nm (8 in-lbs).
3. After wiring is complete, remove the debris shield.

### TIP

If you need to remove the finger-safe cover, insert a screw driver into one of the square wiring holes and gently pry the cover off. If you wire the terminal block with the finger-safe cover removed, you will not be able to put it back on the terminal block because the wires will be in the way.

## Wire Size and Terminal Screw Torque

Each terminal accepts up to two wires with the following restrictions:

Wire Type		Wire Size	Terminal Screw Torque
Solid	Cu-90°C (194°F)	#14 to #22 AWG	0.904 Nm (8 in-lbs)
Stranded	Cu-90°C (194°F)	#16 to #22 AWG	0.904 Nm (8 in-lbs)

## Labeling the Terminals

A write-on label is provided with the module. Mark the identification of each terminal with permanent ink, and slide the label back into the door.

## 1762 Expansion I/O Addressing

The addressing scheme for 1762 Expansion I/O is represented in the following figure.

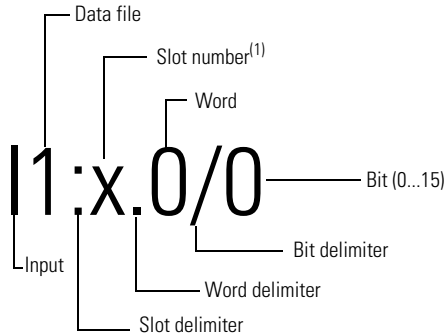

<sup>(1)</sup> I/O located on the controller (embedded I/O) is slot 0. I/O added to the controller (expansion I/O) begins with slot 1.

## Input Data File

For each module, slot x, words 0 through 3 contain the analog values of the inputs. The module can be configured to use either raw/proportional data or scaled-for-PID data. The input data file for either configuration is shown below.

Word	Bit Position															
	15	14	13	12	11	10	9	8	7	6	5	4	3	2	1	0
0	SGN0		Channel 0 Data													
1	SGN1		Channel 1 Data													
2	SGN2		Channel 2 Data													
3	SGN3		Channel 3 Data													
4	reserved											S3	S2	S1	S0	
5	U0	U0	U1	U1	U2	U2	U3	U3	reserved							
6	reserved															

The bits are defined as follows:

- Sx = General status bits for channels 0 through 3. This bit is set when an error (over or under-range) exists for that channel, or there is a general module hardware error.
- Ox = Over-range flag bits for channels 0 through 3. These bits are set when the input signal is above the user-specified range. The module continues to convert data to the maximum full range value during an over-range condition. The bits reset when the over-range condition clears.
- Ux = Under-range flag bits for input channels 0 through 3. These bits are set when the input signal is below the user-specified range. The module continues to convert data to the maximum full range value during an under-range condition. The bits reset when the under-range condition clears.
- SGNx = The sign bit for channels 0 through 3.

## Configuration Data File

The configuration of the format for analog inputs is made at going to run (GTR). Changes made to the configuration file while in run mode have no effect.

The configuration table is shown below.

Word	Bit Position															
	15	14	13	12	11	10	9	8	7	6	5	4	3	2	1	0
0	reserved	Data Format Channel 0			Type/Range Select Channel 0				reserved				Filter Select Channel 0			
1		Data Format Channel 1			Type/Range Select Channel 1				reserved				Filter Select Channel 1			
2		Data Format Channel 2			Type/Range Select Channel 2				reserved				Filter Select Channel 2			
3		Data Format Channel 3			Type/Range Select Channel 3				reserved				Filter Select Channel 3			
4	reserved															
5	reserved															
6	reserved															
7	reserved															

### *Bit 15 and Bits 7 through 4 - Reserved*

These bits are reserved and are not checked by the module.

*Data Format (Bits 14 through 12)*

These bits indicate the format of the data as shown in the following table. Other combinations of these bits are not supported and result in an error.

Bit Settings			Data Format
14	13	12	
0	0	0	Raw/Proportional
0	1	0	Scaled for PID
other			Not Supported

*Type/Range Select (Bits 11 through 8)*

These bits indicate the type and range as in the following table. Other combinations of these bits are not supported and result in an error.

Bit Settings				Data Format
11	10	9	8	
0	0	0	0	Voltage Mode -10 to +10V dc
0	0	1	1	Current Mode 4 to 20 mA
other				Not Supported

*Filter Select (Bits 3 through 0)*

These bits indicate the filter (for desired normal mode rejection) as shown in the table below. Other combinations of these bits are not supported and result in an error.

Bit Settings				Filter Frequency	4-Channel Conversion Time	Attenuation at Filter Frequency
3	2	1	0			
0	0	0	0	60 Hz	450 ms	>55dB
0	0	0	1	50 Hz	530 ms	>55dB
0	0	1	0	60 Hz	250 ms	>20dB
0	0	1	1	50 Hz	290 ms	>20dB
0	1	0	0	No filter	130 ms	—

## Error Codes

The 1762-IF4 module notifies the controller of critical and non-critical errors. The module condition array word 0 contains the error codes that are generated by the module, as shown below.

"Don't Care" Bits				Module Error			Extended Error Information								
15	14	13	12	11	10	9	8	7	6	5	4	3	2	1	0
0	0	0	0	0	0	0	0	0	0	0	0	0	0	0	0
Hex Digit 4				Hex Digit 3			Hex Digit 2				Hex Digit 1				

The table below describes the module error codes.

Error Type	Hex Equivalent <sup>(1)</sup>	Module Error Code	Extended Error Information Code	Error Description
		Binary	Binary	
No Error	X000	000	0 0000 0000	No error
General Common Hardware Error	X200	001	0 0000 0000	General hardware error; no additional information
	X201	001	0 0000 0001	Power-up reset state
Hardware-Specific Error	X300	001	1 0000 0000	Reserved
Configuration Error	X400	010	0 0000 0000	General configuration error; no additional information
	X401	010	0 0000 0001	Invalid range select (Channel 0)
	X402	010	0 0000 0010	Invalid range select (Channel 1)
	X403	010	0 0000 0011	Invalid range select (Channel 2)
	X404	010	0 0000 0100	Invalid range select (Channel 3)
	X405	010	0 0000 0101	Invalid filter select (Channel 0)
	X406	010	0 0000 0110	Invalid filter select (Channel 1)
	X407	010	0 0000 0111	Invalid filter select (Channel 2)
	X408	010	0 0000 1000	Invalid filter select (Channel 3)
	X409	010	0 0000 1001	Invalid format select (Channel 0)
	X40A	010	0 0000 1010	Invalid format select (Channel 1)
	X40B	010	0 0000 1011	Invalid format select (Channel 2)
	X40C	010	0 0000 1100	Invalid format select (Channel 3)

<sup>(1)</sup> X represents "Don't Care".

## Specifications

### Input

Attribute	Value
Number of inputs	4 differential (bipolar)
A/D converter type	Sigma-Delta
Common mode voltage range <sup>(1)</sup>	±27V
Common mode rejection <sup>(2)</sup>	> 55 dB at 50 and 60 Hz
Non-linearity (in percent full scale)	±0.12%
Typical overall accuracy <sup>(3)</sup>	±0.32% full scale at -20...65 °C (-4 °F...149 °F) ±0.24% full scale at 25 °C (77 °F)
Input impedance	Voltage terminal: 200KΩ Current terminal: 275Ω
Current input protection	±32 mA
Voltage input protection	±30V
Channel diagnostics	Over or under range or open circuit condition by bit reporting for analog inputs.

<sup>(1)</sup> For proper operation, both the plus and minus input terminals must be within ±27V of analog common.

<sup>(2)</sup>  $V_{cm} = 1 V_{pk-pk} AC$

<sup>(3)</sup>  $V_{cm} = 0$  (includes offset, gain, non-linearity and repeatability error terms)

### General

Attribute	Value
Dimensions HxWxD	90 x 40.4 x 87 mm (3.54 x 1.59 x 3.43 in.)
Approximate shipping weight (with carton)	235 g (8.28 oz)
Bus current draw, max	40 mA at 5V DC 50 mA at 24V DC
Analog normal operating range	Voltage: -10...+10V DC Current: 4...20 mA

**General**

<b>Attribute</b>	<b>Value</b>
Full scale <sup>(1)</sup> analog ranges	Voltage: -10.5...+10.5V DC Current: -21...+21 mA
Resolution	15 bits (bipolar)
Repeatability <sup>(2)</sup>	±0.12%
Input group to system isolation	30V AC/30V DC rated working voltage <sup>(4)</sup> (IEC Class 2 reinforced insulation) type test: 500V AC or 707V DC for 1 minute
Module power LED	On: indicates power is applied.
Recommended cable	Belden 8761 (shielded)
Vendor ID code	1
Product type code	10
Product code	67
Wire size	See Wire Size and Terminal Screw Torque on page 17
Wiring category <sup>(3)</sup>	2 - on signal ports
Pilot duty rating	Not rated
Enclosure type rating	IP20
North American temp code	T3C

<sup>(1)</sup> The over- or under-range flag comes on when the normal operating range (over/under) is exceeded. The module continues to convert the analog input up to the maximum full scale range.

<sup>(2)</sup> Repeatability is the ability of the input module to register the same reading in successive measurements for the same input signal.

<sup>(3)</sup> Use this Conductor Category information for planning conductor routing. Refer to Industrial Automation Wiring and Grounding Guidelines, publication [1770-4.1](#).

<sup>(4)</sup> Rated working voltage is the maximum continuous voltage that can be applied at the terminals with respect to earth ground.

**Environmental**

<b>Attribute</b>	<b>Value</b>
Temperature, operating	IEC 60068-2-1 (Test Ad, Operating Cold), IEC 60068-2-2 (Test Bd, Operating Dry Heat), IEC 60068-2-14 (Test Nb, Operating Thermal Shock): -20... 65 °C (-4...149 °F)
Temperature, storage	IEC 60068-2-1 (Test Ab, Unpackaged Non-operating Cold), IEC 60068-2-2 (Test Bb, Unpackaged Non-operating Dry Heat), IEC 60068-2-14 (Test Na, Unpackaged Non-operating Thermal Shock): -40...85 °C (-40...185 °F)
Relative humidity	IEC 60068-2-30 (Test Db, Unpackaged Damp Heat): 5...95% non-condensing
Vibration	IEC 60068-2-6 (Test Fc, Operating): 5 g @ 10... 500 Hz
Altitude, operating max	2000 m (6562 ft)
Shock, operating	IEC 60068-2-27 (Test Ea, Unpackaged Shock): 30 g
Shock, nonoperating	IEC 60068-2-27 (Test Ea, Unpackaged Shock): Panel mount - 50 g DIN mount - 40 g
Emissions	CISPR 11 Group 1, Class A
ESD immunity	IEC 61000-4-2: 4 kV contact discharges 8 kV air discharges 4 kV indirect
Radiated RF immunity	IEC 61000-4-3: 10V/m with 1 kHz sine-wave 80% AM from 80...2700 MHz
EFT/B immunity	IEC 61000-4-4: ±2 kV at 5 kHz on signal ports
Surge transient immunity	IEC 61000-4-5: ±1 kV shielded line-earth (CM) on signal ports
Conducted RF immunity	IEC 61000-4-6: 10V rms with 1 kHz sine-wave 80% AM from 150 kHz...80 MHz



## Certifications

Certification (when product is marked) <sup>(1)</sup>	Value
c-UL-us	UL Listed Industrial Control Equipment, certified for US and Canada. See UL File E322657.  UL Listed for Class I, Division 2 Group A,B,C,D Hazardous Locations, certified for U.S. and Canada. See UL File E334470.
CE	European Union 2004/108/EC EMC Directive, compliant with: EN 61326-1; Meas./Control/Lab., Industrial Requirements EN 61000-6-2; Industrial Immunity EN 61000-6-4; Industrial Emissions EN 61131-2; Programmable Controllers (Clause 8, Zone A & B)
C-Tick	Australian Radiocommunications Act, compliant with: AS/NZS CISPR 11; Industrial Emissions

<sup>(1)</sup> See the Product Certification link at <http://www.ab.com> for Declaration of Conformity, Certificates, and other certification details.

**Notes:**



# Rockwell Automation Support

Rockwell Automation provides technical information on the Web to assist you in using its products. At <http://support.rockwellautomation.com>, you can find technical manuals, a knowledge base of FAQs, technical and application notes, sample code and links to software service packs, and a MySupport feature that you can customize to make the best use of these tools.

For an additional level of technical phone support for installation, configuration and troubleshooting, we offer TechConnect support programs. For more information, contact your local distributor or Rockwell Automation representative, or visit <http://support.rockwellautomation.com>.

## Installation Assistance

If you experience a problem with a hardware module within the first 24 hours of installation, please review the information that's contained in this manual. You can also contact a special Customer Support number for initial help in getting your module up and running:

United States	1.440.646.3434 Monday – Friday, 8am – 5pm EST
Outside United States	Please contact your local Rockwell Automation representative for any technical support issues.

## New Product Satisfaction Return

Rockwell Automation tests all of its products to ensure that they are fully operational when shipped from the manufacturing facility. However, if your product is not functioning and needs to be returned, follow these procedures.

United States	Contact your distributor. You must provide a Customer Support case number (see phone number above to obtain one) to your distributor in order to complete the return process.
Outside United States	Please contact your local Rockwell Automation representative for return procedure.

Allen-Bradley, Rockwell Automation, MicroLogix, and TechConnect are trademarks of Rockwell Automation, Inc. Trademarks not belonging to Rockwell Automation are property of their respective companies.

[www.rockwellautomation.com](http://www.rockwellautomation.com)

### Power, Control and Information Solutions Headquarters

Americas: Rockwell Automation, 1201 South Second Street, Milwaukee, WI 53204-2496 USA, Tel: (1) 414.382.2000, Fax: (1) 414.382.4444

Europe/Middle East/Africa: Rockwell Automation, Vorstlaan/Boulevard du Souverain 36, 1170 Brussels, Belgium, Tel: (32) 2 663 0600, Fax: (32) 2 663 0640

Asia Pacific: Rockwell Automation, Level 14, Core F, Cyberport 3, 100 Cyberport Road, Hong Kong, Tel: (852) 2887 4788, Fax: (852) 2508 1846

Publication 1762-IN012B-EN-P - April 2011

Supersedes Publication 1762-IN012A-EN-P - August 2009

40071-117-01(2)

Copyright © 2011 Rockwell Automation, Inc. All rights reserved. Printed in Malaysia.

