

FLEX™ I/O Dual Port EtherNet/IP Adapter Modules

Catalog Numbers 1794-AENTR, 1794-AENTRXT Series A

Table of Contents

Topic	Page
Important User Information	2
Environment and Enclosure	3
Prevent Electrostatic Discharge	3
European Hazardous Location Approval	4
North American Hazardous Location Approval	6
Overview	7
Install Your Adapter	8
Status Indicators	15
Specifications	17

Important User Information

Solid-state equipment has operational characteristics differing from those of electromechanical equipment. Safety Guidelines for the Application, Installation and Maintenance of Solid State Controls (Publication [SGI-1.1](#) available from your local Rockwell Automation sales office or online at <http://www.rockwellautomation.com/literature/>) describes some important differences between solid-state equipment and hard-wired electromechanical devices. Because of this difference, and also because of the wide variety of uses for solid-state equipment, all persons responsible for applying this equipment must satisfy themselves that each intended application of this equipment is acceptable.





In no event will Rockwell Automation, Inc. be responsible or liable for indirect or consequential damages resulting from the use or application of this equipment.

The examples and diagrams in this manual are included solely for illustrative purposes. Because of the many variables and requirements associated with any particular installation, Rockwell Automation, Inc. cannot assume responsibility or liability for actual use based on the examples and diagrams.

No patent liability is assumed by Rockwell Automation, Inc. with respect to use of information, circuits, equipment, or software described in this manual.

Reproduction of the contents of this manual, in whole or in part, without written permission of Rockwell Automation, Inc., is prohibited.

Throughout this manual, when necessary, we use notes to make you aware of safety considerations.

	WARNING: Identifies information about practices or circumstances that can cause an explosion in a hazardous environment, which may lead to personal injury or death, property damage, or economic loss.
	ATTENTION: Identifies information about practices or circumstances that can lead to personal injury or death, property damage, or economic loss. Attentions help you identify a hazard, avoid a hazard and recognize the consequences.
	SHOCK HAZARD: Labels may be on or inside the equipment (for example, drive or motor) to alert people that dangerous voltage may be present.
	BURN HAZARD: Labels may be on or inside the equipment (for example, drive or motor) to alert people that surfaces may reach dangerous temperatures.
IMPORTANT	Identifies information that is critical for successful application and understanding of the product.

Environment and Enclosure



ATTENTION: This equipment is intended for use in a Pollution Degree 2 industrial environment, in overvoltage Category II applications (as defined in IEC 60664-1), at altitudes up to 2000 m (6562 ft) without derating.

This equipment is not intended for use in residential environments and may not provide adequate protection to radio communication services in such environments.

This equipment is supplied as open-type equipment. It must be mounted within an enclosure that is suitably designed for those specific environmental conditions that will be present and appropriately designed to prevent personal injury resulting from accessibility to live parts. The enclosure must have suitable flame-retardant properties to prevent or minimize the spread of flame, complying with a flame spread rating of 5VA or be approved for the application if nonmetallic. The interior of the enclosure must be accessible only by the use of a tool. Subsequent sections of this publication may contain additional information regarding specific enclosure type ratings that are required to comply with certain product safety certifications.

In addition to this publication, see the following:

- Industrial Automation Wiring and Grounding Guidelines, publication [1770-4.1](#), for additional installation requirements.
- NEMA Standard 250 and IEC 60529, as applicable, for explanations of the degrees of protection provided by enclosures.

Prevent Electrostatic Discharge



ATTENTION: This equipment is sensitive to electrostatic discharge, which can cause internal damage and affect normal operation. Follow these guidelines when you handle this equipment:

- Touch a grounded object to discharge potential static.
 - Wear an approved grounding wriststrap.
 - Do not touch connectors or pins on component boards.
 - Do not touch circuit components inside the equipment.
 - Use a static-safe workstation, if available.
 - Store the equipment in appropriate static-safe packaging when not in use.
-

European Hazardous Location Approval

The following adapters are European Zone 2 approved:
1794-AENTR, 1794-AENTRXT Series A.

European Zone 2 Certification (The following applies when the product bears the Ex Marking)

This equipment is intended for use in potentially explosive atmospheres as defined by European Union Directive 94/9/EC.

DEMKO certifies that this equipment has been found to comply with the Essential Health and Safety Requirements relating to the design and construction of Category 3 equipment intended for use in Zone 2 potentially explosive atmospheres, given in Annex II to this Directive.

Compliance with the Essential Health and Safety Requirements has been assured by compliance with EN 60079-15.



WARNING: Observe the following additional Zone 2 certification requirements:



- This equipment is not resistant to sunlight or other sources of UV radiation.
 - This equipment shall be mounted in an ATEX-certified enclosure with a minimum ingress protection rating of at least IP54 (as defined in IEC60529) and used in an environment of not more than Pollution Degree 2 (as defined in IEC 60664-1) when applied in Zone 2 environments. The enclosure must have a tool-removable cover or door.
 - This equipment shall be used within its specified ratings defined by Rockwell Automation.
 - Provision shall be made to prevent the rated voltage from being exceeded by transient disturbances of more than 140% of the rated voltage when applied in Zone 2 environments.
 - This equipment must be used only with ATEX certified Rockwell Automation backplanes.
 - Secure any external connections that mate to this equipment by using screws, sliding latches, threaded connectors, or other means provided with this product.
 - Do not disconnect equipment unless power has been removed or the area is known to be nonhazardous.
-



- Enclosure must be marked with the following: "Warning - Do not open when energized" After installation of equipment into the enclosure, access to termination compartments shall be dimensioned so that conductors can be readily connected.
 - For Class I Division 2 applications, use only Class I Division 2 listed or recognized accessories and modules approved for use within the 1794 platform.
-

North American Hazardous Location Approval

The following modules are North American Hazardous Location approved:
1794-AENTR, 1794-AENTRXT Series A

The following information applies when operating this equipment in hazardous locations:	Informations sur l'utilisation de cet équipement en environnements dangereux:
<p>Products marked "CL I, DIV 2, GP A, B, C, D" are suitable for use in Class I Division 2 Groups A, B, C, D, Hazardous Locations and nonhazardous locations only. Each product is supplied with markings on the rating nameplate indicating the hazardous location temperature code. When combining products within a system, the most adverse temperature code (lowest "T" number) may be used to help determine the overall temperature code of the system. Combinations of equipment in your system are subject to investigation by the local Authority Having Jurisdiction at the time of installation.</p>	<p>Les produits marqués "CL I, DIV 2, GP A, B, C, D" ne conviennent qu'à une utilisation en environnements de Classe I Division 2 Groupes A, B, C, D dangereux et non dangereux. Chaque produit est livré avec des marquages sur sa plaque d'identification qui indiquent le code de température pour les environnements dangereux. Lorsque plusieurs produits sont combinés dans un système, le code de température le plus défavorable (code de température le plus faible) peut être utilisé pour déterminer le code de température global du système. Les combinaisons d'équipements dans le système sont sujettes à inspection par les autorités locales qualifiées au moment de l'installation.</p>
<div style="display: flex; align-items: center;">  <div> <p>WARNING: EXPLOSION HAZARD</p> <ul style="list-style-type: none"> Do not disconnect equipment unless power has been removed or the area is known to be nonhazardous. Do not disconnect connections to this equipment unless power has been removed or the area is known to be nonhazardous. Secure any external connections that mate to this equipment by using screws, sliding latches, threaded connectors, or other means provided with this product. Substitution of components may impair suitability for Class I, Division 2. If this product contains batteries, they must only be changed in an area known to be nonhazardous. </div> </div>	<div style="display: flex; align-items: center;">  <div> <p>AVERTISSEMENT: RISQUE D'EXPLOSION</p> <ul style="list-style-type: none"> Couper le courant ou s'assurer que l'environnement est classé non dangereux avant de débrancher l'équipement. Couper le courant ou s'assurer que l'environnement est classé non dangereux avant de débrancher les connecteurs. Fixer tous les connecteurs externes reliés à cet équipement à l'aide de vis, loquets coulissants, connecteurs filetés ou autres moyens fournis avec ce produit. La substitution de composants peut rendre cet équipement inadapté à une utilisation en environnement de Classe I, Division 2. S'assurer que l'environnement est classé non dangereux avant de changer les piles. </div> </div>



ATTENTION: To comply with the CE Low Voltage Directive (LVD), this equipment must be powered from a source compliant with the following: Safety Extra Low Voltage (SELV) or Protected Extra Low Voltage (PELV).



ATTENTION: FLEX I/O is grounded through the DIN rail to chassis ground. Use zinc plated yellow-chromate steel DIN rail to assure proper grounding. The use of other DIN rail materials (for example, aluminum or plastic) that can corrode, oxidize, or are poor conductors, can result in improper or intermittent grounding. Secure DIN rail to mounting surface approximately every 200 mm (7.8 in.) and use end-anchors appropriately.

Overview

1794 Dual Port EtherNet/IP Adapter

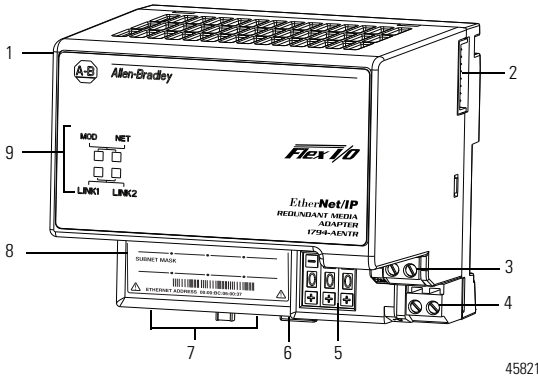

45821

Component Identification

	Description		Description
1	Dual-port EtherNet/IP adapter	6	Module locking tab
2	Flexbus connector	7	Network cable RJ45 connectors (underside)
3	24V common connections	8	MAC ID label
4	24V DC connections	9	Status indicators
5	IP address switches		

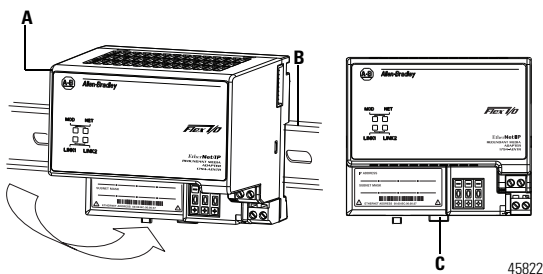
Install Your Adapter

45822



ATTENTION: During mounting of all devices, be sure that all debris (for example, metal chips, wire strands) is kept from falling into the module. Debris that falls into the module could cause damage on power up.



ATTENTION: Do not remove or replace an Adapter Module while power is applied. Interruption of the backplane can result in unintentional operation or machine motion.

Mounting Dimensions

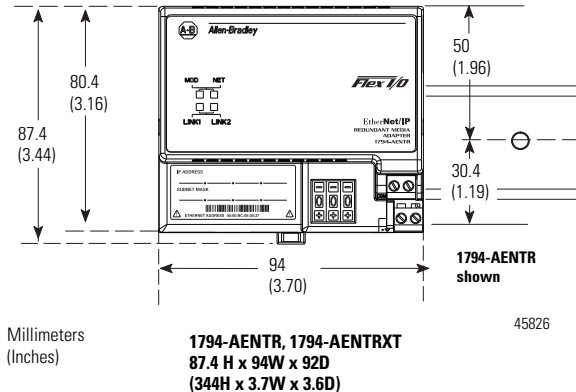

Mount on a DIN Rail

1. Position the adapter module (A) on an IEC standard (35 x 7.5 x 1 mm) top-hat DIN rail (B) at a slight angle (DIN rail: Allen-Bradley part number 199-DR1; 46277-3; EN50022).
2. Hook the lip on the rear of the adapter onto the top of the DIN rail, and rotate the adapter module onto the rail.
3. Press the adapter module down onto the DIN rail until flush. Locking tab (C) snaps the adapter into position and locks it onto the DIN rail.
4. If the adapter module does not lock in place, use a screwdriver or similar device to move the locking tab down while pressing the adapter module flush onto the DIN rail, and release the locking tab to lock the adapter module in place. If necessary, push up on the locking tab to lock.
5. Connect the adapter wiring as shown in the section, [Connect Wiring on page 12](#).

Mount on a Panel or Wall

If mounting this adapter to a panel or wall, refer to publication [1794-IN135](#), Panel Mounting Kit, Cat. No. 1794-NM1/B.



WARNING: If you insert or remove the module while backplane power is on, an electrical arc can occur. This could cause an explosion in hazardous location installations. Be sure that power is removed or the area is nonhazardous before proceeding.



WARNING: When used in a Class I, Division 2, hazardous location, this equipment must be mounted in a suitable enclosure with proper wiring method that complies with the governing electrical codes.

Mount or Replace the Adapter on an Existing System

1. Disconnect any wiring jumpered to the adjacent terminal base.
 2. Remove the Ethernet connectors from the bottom of the adapter.
-



WARNING: If you connect or disconnect the communication cable with power applied to the adapter or any device on the network, an electrical arc can occur. This could cause an explosion in hazardous location installations. Be sure that power is removed or the area is nonhazardous before proceeding.

3. Disconnect any user power wiring connections to the adapter.
 4. Open the module latching mechanism and remove the module from the base unit to which the adapter will be attached.
 5. Push the Flexbus connector toward the right side of the terminal base to unplug the backplane connection.
-



ATTENTION: Make certain the Flexbus connector is completely clear of the adapter. The slide must be completely to the right and the raised spot on the slide visible.

6. Release the locking tab and remove the adapter module.
Before installing the new adapter, notice the notch on the right rear of the adapter. This notch accepts the hook on the terminal base unit. The notch is open at the bottom. The hook and adjacent connection point keep the terminal base and the adapter tight together, reducing the possibility of a break in communication over the backplane.

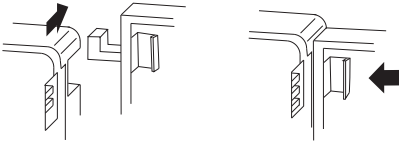

7. Complete the adapter mounting as shown below.
Push down and in at the same time to lock the adapter to the DIN rail.
If the adapter does not lock in place, use a screwdriver or similar device to move the locking tab down while pressing the adapter flush onto the DIN rail, and release the locking tab to lock the adapter module in place. If necessary, push up on the locking tab to lock.

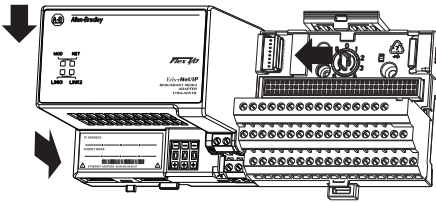

When the adapter is locked onto the DIN rail, gently push the Flexbus connector into the adapter to complete the backplane.

8. Reinstall the module in the adjacent terminal base unit.

Connect Wiring

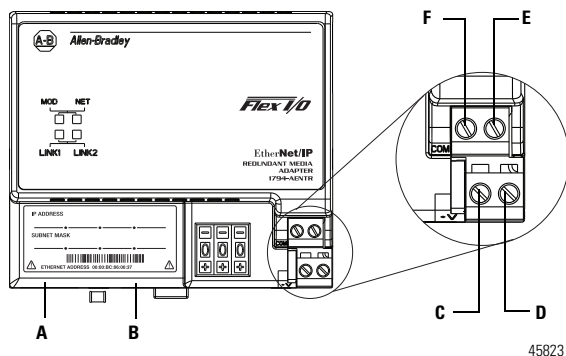

WARNING: If you connect or disconnect wiring while the field-side power is on, an electrical arc can occur. This could cause an explosion in hazardous location installations. Be sure that power is removed or the area is nonhazardous before proceeding.

1. Connect an Ethernet network cable to the RJ45 connector (A).
2. Connect the redundant Ethernet network cable to the RJ45 connector (B).

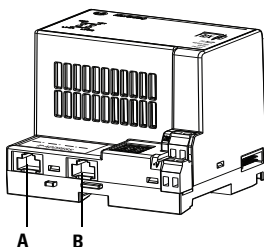

**ATTENTION:**

- When connecting wiring, torque terminal screws C, D, E and F to 0.8 Nm (7 lb-in.).
- If multiple power sources are used, do not exceed the specified isolation voltage.
- Power wiring must be less than 10 m (32.8 ft.) in length.
- Do not wire more than two conductors on any single terminal.

3. Connect 24V DC common to the left side of the upper connector, terminal **F**.
4. Connect +24V DC input power to the left side of the lower connector, terminal **C**.
5. Connections **D** and **E** are used to pass +24V DC common (**E**) and 24V DC power (**D**) to the next module in the series (if required).

Set the Network Address

The adapter ships with the thumbwheel switches set to 999 and DHCP enabled. You can set the network Internet Protocol (IP) address in these ways:

- Use the thumbwheel switches on the module.
- Use a Dynamic Host Configuration Protocol (DHCP) server, such as Rockwell Automation DHCP.
- Retrieve the IP address (if previously set) from nonvolatile memory.

The adapter reads the thumbwheel switches first to determine if the switches are set to a valid number. You set the node address by using the three-position thumbwheel switch. Press the + or - buttons to change the number. Valid settings are 001...254.

When the switches are set to a valid number, the adapter's IP address is 192.168.1.xxx (where xxx represents the number set on the switches). The adapter subnet mask is set to 255.255.255.0. The adapter gateway address is set differently depending on the firmware revision:

- For Firmware Revision 1.013 and earlier, when the address switches are set to 001...254, the adapter gateway address is set to 0.0.0.0.
- For Firmware Revision 1.014, when the address switches are set to 001, the adapter gateway address is set to 0.0.0.0. When the address switches are set to 002...254, the adapter gateway address is set to 192.168.1.1.

The adapter does not have a host name assigned, or use any Domain Name System when using the thumbwheel settings.

Press the + or - buttons to change the numbers

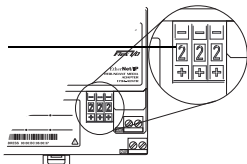

45824

If you set the switches to an invalid number (such as 000, or a value greater than 254), the adapter checks to see if you enabled DHCP.

DHCP Enabled and Not Enabled

DHCP State	Adapter Action
Enabled	Asks for an address from a DHCP server. The DHCP server also assigns other Transport Control Protocol (TCP) parameters.
Not enabled	Uses the IP address (along with other TCP configurable parameters) stored in nonvolatile memory.

Status Indicators

The module has LED status indicators to specify its status and aid the user in troubleshooting.

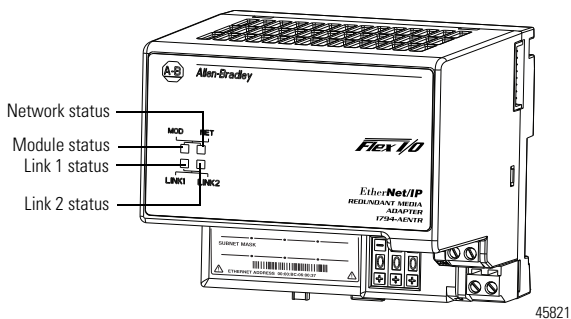

Status Indicators

Indicator	Status
Link 1 or Link 2 (individually)	
Off	No link exists. Verify network cabling. Correct as necessary.
Solid green	Link exists @ 100 Mbps.
Flashing green	I/O is being transmitted or received @ 100 Mbps.
Flashing yellow	I/O is being transmitted or received @ 10 Mbps.
Solid yellow	Link exists @ 10 Mbps.
Module Status Indicator	
Off	No power. Adapter does not have 24V DC power. Make sure power is being supplied to the adapter.
Flashing green	Standby. Adapter not configured. Configure adapter.
Green	Operational. Adapter operating correctly. No action required.
Flashing red	Minor fault. A recoverable fault has been detected. This could be caused by an incorrect or inconsistent configuration. Check configuration and reconfigure as needed.

Status Indicators

Indicator	Status
Solid red	Major fault. An unrecoverable fault has been detected. Recycle power to the adapter. If this does not clear the fault, replace the adapter.
Flashing red/green	Self test. Adapter performing power-up self test. Wait until completed.

Network Status Indicator

Off	Not powered. No IP address. Adapter is not powered or does not have an IP address. <ul style="list-style-type: none"> • Verify there is power and the adapter is correctly wired to the power supply. • Make sure the adapter is configured.
Flashing green	No connection. Adapter has obtained an IP address, but has no established connections.
Green	CIP connections. Adapter has an IP address and at least one established connection.
Flashing red	Connection timeout. One or more of the connections in which the adapter is the target has timed out.
Red	Duplicate IP address. Adapter has detected that its IP address is already in use. Configure the adapter with a unique IP address.
Flashing red/green	Self-test. Adapter performing power-up self test.

Specifications

General Specifications

Attribute	1794-AENTR	1794-AENTRXT ⁽²⁾
I/O module capacity	8	
Communication rate	10/100 Mbps	
Indicators	Module status – red/green Network status – red/green Link 1 status – yellow/green Link 2 status – yellow/green	
Power supply	To comply with the CE Low Voltage Directive (LVD), this equipment must be powered from a source compliant with the following: Safety Extra Low Voltage (SELV) or Protected Extra Low Voltage (PELV).	
Enclosure type rating	None (open-style)	
Input voltage range	19.2...31.2V DC (includes 5% AC ripple)	
Input voltage, nom	24V DC	
Inrush current	18 A for 2 ms	
Flexbus output, max	640 mA @ 5V DC	
Isolation voltage	50V continuous, Basic Insulation Type Tested @ 1000V AC for 60 s, power to Flexbus to EtherNet	
Power consumption, max	500 mA 400 mA @ 24V DC	
Power dissipation, max	7.1 W @ 19.2V DC	6.1 W @ 19.2V DC
Thermal dissipation	24.2 BTU/hr @ 24V DC	20.8 BTU/hr @ 24V DC
Wire size, power conductors	0.33...3.31 mm ² (22...12 AWG) stranded copper wire rated at 75 °C (167 °F) or greater, 1.2 mm (3/64 in.) insulation max	
Wire category ⁽¹⁾	1 – on power ports 1 – on communications ports	
Ethernet connector	2 Ethernet RJ45 Category 5	
North American temperature code	T5	T4A
IEC Temp code	T5	T4

General Specifications

Attribute	1794-AENTR	1794-AENTRXT ⁽²⁾
Terminal screw torque	0.8 Nm (7 lb-in.)	
Dimensions, approx. (HxWxD)	87 x 94 x 92 mm 3.4 x 3.7 x 3.6 in.	
Weight, approx.	227 g (8.01 oz)	

⁽¹⁾ Use this conductor category information for planning conductor routing as described in the system-level installation manual. See the Industrial Automation Wiring and Grounding Guidelines, publication [1770-4.1](#).

⁽²⁾ 1794-AENTRXT module is conformally coated to meet noxious gas requirements of ISA/ANSI-71.040 1985 Class G3 Environment.

Environmental Specifications

Attribute	1794-AENTR	1794-AENTRXT
Temperature, operating	IEC 60068-2-1 (Test Ad, Operating Cold), IEC 60068-2-2 (Test Bd, Operating Dry Heat), IEC 60068-2-14 (Test Nb, Operating Thermal Shock):	
	0...55 °C (32...131 °F)	-25...70 °C (-13...158 °F)
Temperature, surrounding air, max	55 °C (131 °F)	70 °C (158 °F)
Temperature, nonoperating	IEC 60068-2-1 (Test Ab, Unpackaged Nonoperating Cold), IEC 60068-2-2 (Test Bb, Unpackaged Nonoperating Dry Heat), IEC 60068-2-14 (Test Na, Unpackaged Nonoperating Thermal Shock): -40...85 °C (-40...185 °F)	
Relative humidity	IEC 60068-2-30 (Test Db, Unpackaged Nonoperating Damp Heat): 5...95% noncondensing	
Vibration	IEC 60068-2-6 (Test Fc, Operating): 5 g @ 10...500 Hz	
Shock, operating	IEC 60068-2-27 (Test Ea, Unpackaged Shock): 30 g	
Shock, nonoperating	IEC 60068-2-27 (Test Ea, Unpackaged Shock): 50 g	
Emissions	IEC 61000-6-4	

Environmental Specifications

Attribute	1794-AENTR	1794-AENTRXT
ESD immunity	IEC 61000-4-2: 6 kV contact discharges 8 kV air discharges	
Radiated RF immunity	IEC 61000-4-3: 10V/m with 1 kHz sine-wave 80% AM from 80... 2000 MHz 10V/m with 200 Hz 50% Pulse 100% AM @ 900 MHz 10V/m with 200 Hz 50% Pulse 100% AM @ 1890 MHz 10V/m with 1 kHz sine-wave 80% AM from 2000...2700 MHz	
EFT/B immunity	IEC 61000-4-4: ±4 kV @ 5 kHz on power ports ±4 kV @ 5 kHz on communication ports	
Surge transient immunity	IEC 61000-4-5: ±1 kV line-line (DM) and ±2 kV line-earth (CM) on power ports ±2 kV line-earth (CM) on communication ports	
Conducted RF immunity	IEC 61000-4-6: 10V rms with 1 Hz sine-wave 80% AM from 150 kHz...80 MHz	

Certifications

Certification ⁽¹⁾ (when product is marked)	Value
c-UL-us	UL Listed Industrial Control Equipment, certified for US and Canada. See UL File E65584. UL Listed for Class I, Division 2 Group A,B,C,D Hazardous Locations, certified for U.S. and Canada. See UL File E194810.
CE	European Union 2004/108/IEC EMC Directive, compliant with: EN 61326-1; Meas./Control/Lab., Industrial Requirements EN 61000-6-2; Industrial Immunity EN 61000-6-4; Industrial Emissions EN 61131-2; Programmable Controllers (Clause 8, Zone A & B)
RCM	Australian Radiocommunications Act, compliant with: AS/NZS CISPR 11; Industrial Emissions
EtherNet/IP	ODVA conformance tested to EtherNet/IP specifications

Certifications

Certification⁽¹⁾ (when product is marked)	Value
Ex	European Union 94/9/EC ATEX Directive, compliant with: EN 60079-15:2010; Potentially Explosive Atmospheres, Protection "n" EN 60079-0:2012+A11:2013; General Requirements DEMKO 14 ATEX 1342501X II 3 G Ex nA IIC T5 Gc (for 1794-AENTR) II 3 G Ex nA IIC T4 Gc (for 1794-AENTRXT)
IECEx	IECEx System, compliant with: IEC 60079-15, 4th Edition; Potentially Explosive Atmospheres, Protection "n" IEC 60079-0, 6th Edition; General Requirements Ex nA IIC T5 Gc (for 1794-AENTR) Ex nA IIC T4 Gc (for 1794-AENTRXT) IECEx UL 14.0066X
TÜV	TÜV Certified for Functional Safety: Capable of SIL 2
KC	Korean Registration of Broadcasting and Communications Equipment, compliant with: Article 58-2 of Radio Waves Act, Clause 3
EAC	Russian Customs Union TR CU 020/2011 EMC Technical Regulation

⁽¹⁾ See the Product Certification link at <http://www.rockwellautomation.com/products/certification/> for Declaration of Conformity, Certificates, and other certification details.

Notes:

Notes:

Notes:

Rockwell Automation Support

Rockwell Automation provides technical information on the Web to assist you in using its products. At <http://www.rockwellautomation.com/support/>, you can find technical manuals, a knowledge base of FAQs, technical and application notes, sample code and links to software service packs, and a MySupport feature that you can customize to make the best use of these tools.

For an additional level of technical phone support for installation, configuration and troubleshooting, we offer TechConnect support programs. For more information, contact your local distributor or Rockwell Automation representative, or visit <http://www.rockwellautomation.com/support/>.

Installation Assistance

If you experience a problem within the first 24 hours of installation, please review the information that's contained in this manual. You can also contact a special Customer Support number for initial help in getting your product up and running.

United States or Canada	1.440.646.3434
Outside United States or Canada	Use the Worldwide Locator at http://www.rockwellautomation.com/support/americas/phone_en.html , or contact your local Rockwell Automation representative.

New Product Satisfaction Return

Rockwell Automation tests all of its products to ensure that they are fully operational when shipped from the manufacturing facility. However, if your product is not functioning and needs to be returned, follow these procedures.

United States	Contact your distributor. You must provide a Customer Support case number (call the phone number above to obtain one) to your distributor to complete the return process.
Outside United States	Please contact your local Rockwell Automation representative for the return procedure.

Documentation Feedback

Your comments will help us serve your documentation needs better. If you have any suggestions on how to improve this document, complete this form, publication [RA-DU002](#), available at <http://www.rockwellautomation.com/literature/>.

Allen-Bradley, Rockwell Automation, and FLEX, are trademarks of Rockwell Automation, Inc.

Trademarks not belonging to Rockwell Automation are property of their respective companies.

Rockwell Otomasyon Ticaret A.Ş., Kar Plaza İş Merkezi E Blok Kat:6 34752 İçerenköy, İstanbul, Tel: +90 (216) 5698400

www.rockwellautomation.com

Power, Control and Information Solutions Headquarters

Americas: Rockwell Automation, 1201 South Second Street, Milwaukee, WI 53204-2496 USA, Tel: (1) 414.382.2000, Fax: (1) 414.382.4444
Europe/Middle East/Africa: Rockwell Automation, Vorstlaan/Boulevard du Souverain 36, 1170 Brussels, Belgium, Tel: (32) 2 663 0600, Fax: (32) 2 663 0640
Asia Pacific: Rockwell Automation, Level 14, Core F, Cyberport 3, 100 Cyberport Road, Hong Kong, Tel: (852) 2887 4788, Fax: (852) 2508 1846

Publication 1794-IN131C-EN-P - October 2015

Supersedes Publication 1794-IN131B-EN-P - February 2012

Copyright © 2015 Rockwell Automation, Inc. All rights reserved.