

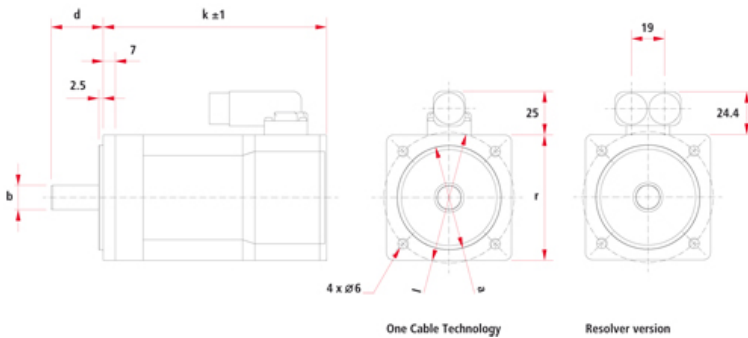

AM813x | Servomotor 1.13 Nm (standstill torque)



Dimensions	a	b	d	l	r	k (without brake)	k (with brake)
AM8131	60 j6	14 k6	30 mm	75 mm	72 mm	128.7 mm	168.2 mm

Accessories	
EL7201-0010	Servomotor EtherCAT Terminal with OCT, 50 V DC, 4 A
ZK4704-0421-xxxx	motor cables for AM81xx servomotors with OCT to EL7201-0010 EtherCAT Terminal
EL7201	Servomotor EtherCAT Terminal 50 V DC, 4 A
ZK4704-0411-xxxx	motor cables for AM31xx/AM81xx servomotors to EL7201 EtherCAT Terminal
ZK4724-0410-xxxx	resolver cables for AM31xx/AM81xx servomotors to EL7201 EtherCAT Terminal
AG2250-+PLE60	Planetary gear units for compact Drive Technology
AG2250-+WPLE60	Angled planetary gear units for compact Drive Technology