

## BECKHOFF Fieldbus Components



## Documentation about Bus Couplers for PROFIBUS-DP

BK3010, BK3110, BK3120, BK3150, BK3500, BK3520 and LC3100

Version: 3.5.1

Date: 2006-02-10

BECKHOFF Automation: Foreword

## Notes on the Documentation

This description is only intended for the use of trained specialists in control and automation engineering who are familiar with the applicable national standards. It is essential that the following notes and explanations are followed when installing and commissioning these components.

### Liability Conditions

The responsible staff must ensure that the application or use of the products described satisfy all the requirements for safety, including all the relevant laws, regulations, guidelines and standards.

The documentation has been prepared with care. The products described are, however, constantly under development. For that reason the documentation is not in every case checked for consistency with performance data, standards or other characteristics. None of the statements of this manual represents a guarantee (Garantie) in the meaning of § 443 BGB of the German Civil Code or a statement about the contractually expected fitness for a particular purpose in the meaning of § 434 par. 1 sentence 1 BGB. In the event that it contains technical or editorial errors, we retain the right to make alterations at any time and without warning. No claims for the modification of products that have already been supplied may be made on the basis of the data, diagrams and descriptions in this documentation.

© This documentation is copyrighted. Any reproduction or third party use of this publication, whether in whole or in part, without the written permission of Beckhoff Automation GmbH, is forbidden.

BECKHOFF Automation: Foreword

## Safety Instructions

### Safety Rules

The responsible staff must ensure that the application or use of the products described satisfy all the requirements for safety, including all the relevant laws, regulations, guidelines and standards.

### State at Delivery

All the components are supplied in particular hardware and software configurations appropriate for the application. Modifications to hardware or software configurations other than those described in the documentation are not permitted, and nullify the liability of Beckhoff Automation GmbH.

### Personnel Qualification

This description is only intended for the use of trained specialists in control and automation engineering who are familiar with the applicable national standards.

### Description of safety symbols

The following safety symbols are used in this operating manual. They are intended to alert the reader to the associated safety instructions.



**Danger**

This symbol is intended to highlight risks for the life or health of personnel.

This symbol is intended to highlight risks for equipment, materials or the environment.



**Warning**



**Note**

This symbol indicates information that contributes to better understanding.

BECKHOFF Fieldbus Components: Foreword

## Documentation Issue Status

Version	Status
3.5.1	Notes about UL certification added
3.5	BK3150 with firmware version B0 added
3.03	Corrections in the context of the translation into the english language
3.02	GSD files updated for BK3110, BK3120, BK3520
3.01	Configuration examples for operation under Siemens S7 expanded.
3.0	For BK3010 with firmware version B9 For BK3110 with firmware version B9 For BK3120 with firmware version B9 For BK3500 with firmware version B9 For BK3520 with firmware version B9 For LC3100 with firmware version B9

BECKHOFF Fieldbus Coupler: Product Overview

## Technical Data

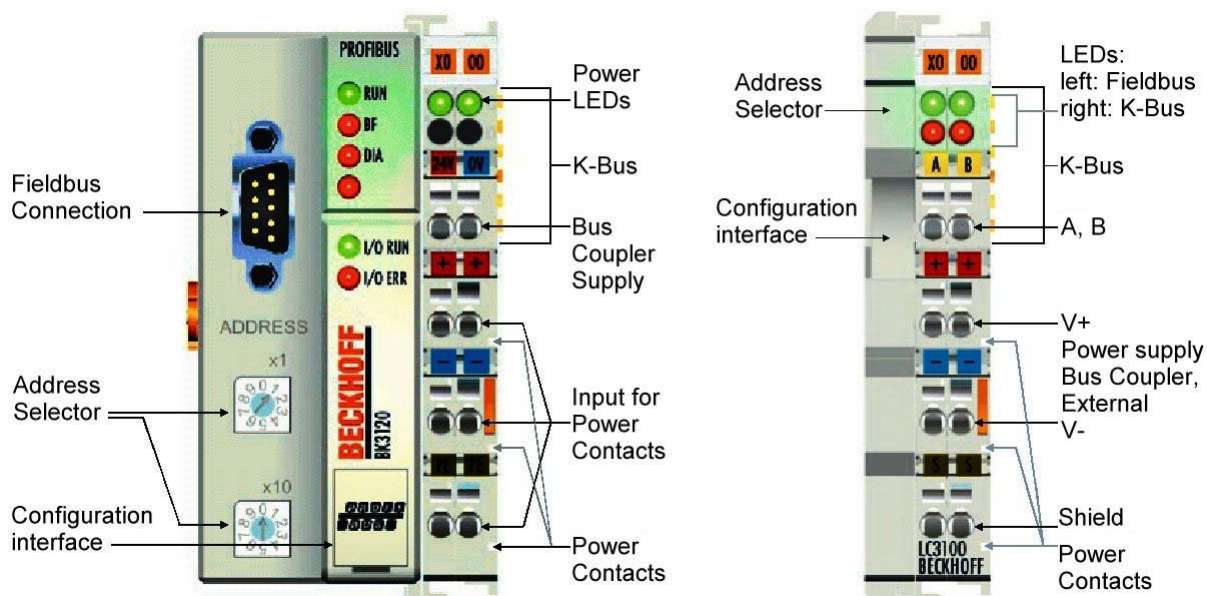

Technical data BK3000, BK3010, BK3100, BK3110, BK3120, LC3100

	BK3000, BK3100,	
--	-----------------	--

Type	BK3010	BK3110	BK3120	LC3100
Number of Bus Terminals	64		64 (255 with K-Bus extension)	64
Digital peripheral signals	512 inputs/outputs		max. 1020 inputs/outputs	256 inputs/outputs
Analog peripheral signals	128 inputs/outputs (BK3x00)		max. 64 inputs/outputs	-
Configuration possibility	Via the KS2000 configuration software or the controller			
Maximum number of bytes (inputs and outputs)	BK3000: 244 bytes	BK3100: 64 bytes (DP and FMS operation) 128 bytes (DP operation only)	128 bytes	32 bytes
	BK3010: 32 bytes	BK3110: 32 bytes		
Baud rate (automatic detection)	up to max. 1.5 MBaud	up to max. 12 MBaud		
Bus connection	1 x D-sub plug, 9-pin with shielding			spring-loaded terminals
Power supply	24 V <sub>DC</sub> (-15 % /+20 %)			
Input current	70 mA + (total K-Bus current)/4, max. 500 mA (BK3x00)	70 mA + (total K-Bus current)/4, max. 200 mA (BK3x10)	70 mA + (total K-Bus current)/4, max. 500 mA	70 mA + (total K-Bus current)/4, max. 200 mA
	70 mA + (total K-Bus current)/4, max. 200 mA (BK3x10)			
Starting current	2.5 x continuous current			
K-Bus current up to	1750 mA (BK3x00)	500 mA (BK3x10)	1750 mA	500 mA
	500 mA (BK3x10)			
Power contact voltage (Up)	maximum 24 V <sub>DC</sub>			
Power contact current load (Up)	maximum 10 A			
Recommended fuse (Up)	maximum 10 A			
Electrical				power

isolation	power contact / supply / fieldbus			supply / fieldbus
Dielectric strength	500 V <sub>rms</sub> (power contact / supply / fieldbus)			500 V <sub>rms</sub> (supply / fieldbus)
Weight	approx. 170 g	approx. 150 g	approx. 170 g	approx. 100 g
Permissible ambient temperature (operation)	0 °C ... +55 °C			
Permissible ambient temperature (storage)	-25 °C ... +85 °C			
Permissible relative humidity	95 % (no condensation)			
Vibration / shock resistance	according to EN 60068-2-6 / EN 60068-2-27, EN 60068-2-29			
EMC resistance Burst / ESD	according to EN 61000-6-2 (EN 50082) / EN 61000-6-4 (EN 50081)			
Protection class	IP 20			
Installation position	variable			

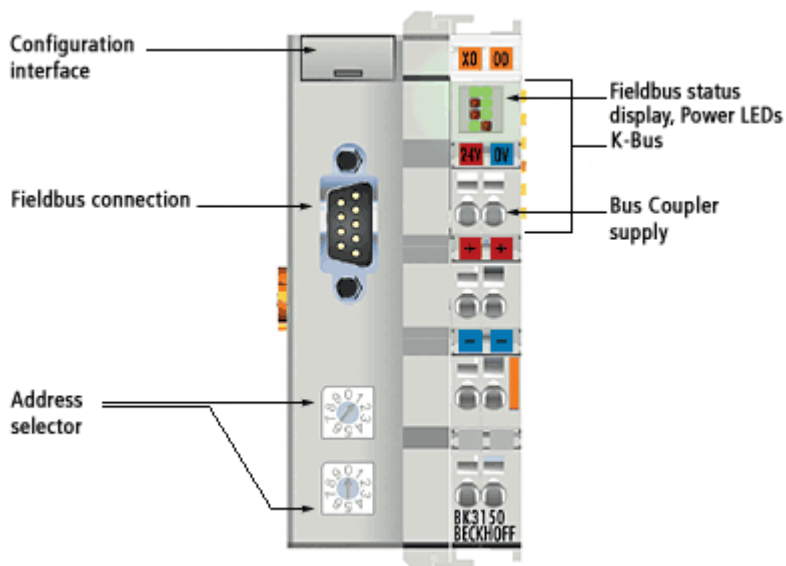

#### Technical data BK3150

Type	BK3150
Number of Bus Terminals	64 (255 with K-Bus extension)
Digital	

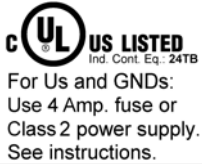
peripheral signals	max. 1020 inputs/outputs
Analog peripheral signals	max. 64 inputs/outputs
Configuration possibility	Via the KS2000 configuration software or the controller
Maximum number of bytes (inputs and outputs)	128 Byte (DP operation only)
Baud rate (automatic detection)	up to max. 12 MBaud
Bus connection	1 x D-sub plug, 9-pin with shielding
Power supply (Us)	 <p>24 V<sub>DC</sub> (-15 % /+20 %) To meet the UL requirements use a 4 A fuse or a power supply that has to satisfy <i>NEC class 2!</i> For Us and GNDs: Use 4 Amp. fuse or Class 2 power supply. See instructions.</p>
Input current (Us)	70 mA + (total K bus current)/4, max. 320 mA
Starting current (Us)	2,5 x continuous current
Recommended fuse	maximum 10 A
K-Bus power supply up to	1000 mA
Power contact voltage	maximum 24 V <sub>DC</sub>
Power contact current load	maximum 10 A
Electrical isolation	power contact / supply / fieldbus
Dielectric strength	500 V <sub>rms</sub> (power contact / supply / fieldbus)
Weight	app. 100 g
Permissible ambient temperature (operation)	0 °C ... +55 °C
Permissible ambient temperature (storage)	-25 °C ... +85 °C
Permissible relative humidity	95 % (no condensation)
Vibration / shock resistance	according to EN 60068-2-6 / EN 60068-2-27, EN 60068-2-29

EMC resistance Burst / ESD	according to EN 61000-6-2 / EN 61000-6-4
Protection class	IP 20
Installation position	variable

BECKHOFF Fieldbus Components: Product Overview

## Technical Data (Optical Fibres)

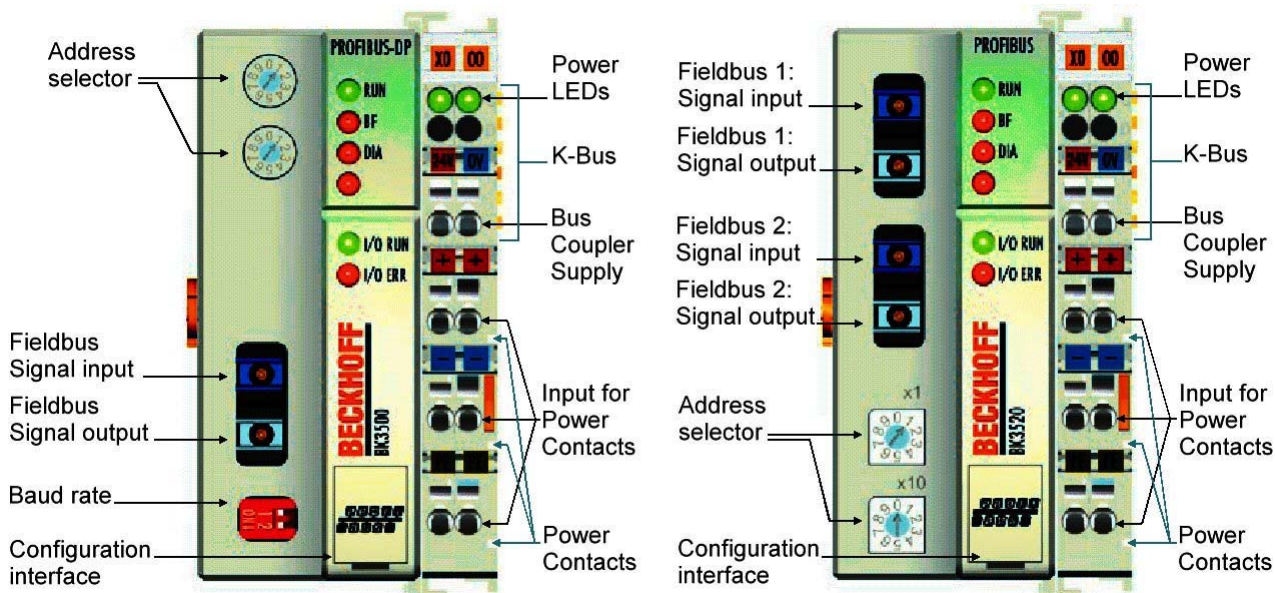

### Technical data

Type	BK3500	BK3520
Number of Bus Terminals	64	64 (255 with K-Bus extension)
Digital peripheral signals	max. 512 inputs/outputs	max. 1020 inputs/outputs
Analog peripheral signals	max. 64 inputs/outputs	max. 64 inputs/outputs
Configuration possibility	Via the KS2000 configuration software or the controller	
Maximum number of bytes (inputs and outputs)	128 bytes	128 bytes
Baud rates	up to max. 1.5 Mbaud (manual setting)	up to max. 12 Mbaud (automatic detection)
Bus connection	1 x optical fibre with 2 HP Simplex connectors	2 x optical fibres with 2 HP Simplex connectors each
Power supply	24 V <sub>DC</sub> (-15 %/+20 %)	
Input current	70 mA + (total K-Bus current)/4, 500	

	mA, 500 mA max.	
Starting current	2.5 x continuous current	
Recommended fuse	maximum 10 A	
K-Bus power supply up to	1750 mA	
Power contact voltage	maximum 24 V <sub>DC</sub>	
Power contact current load	maximum 10 A	
Electrical isolation	power contact / supply / fieldbus	
Dielectric strength	500 V <sub>rms</sub> (power contact / supply / fieldbus)	
Weight	approx. 170 g	approx. 170 g
Permissible ambient temperature (operation)	0 °C ... +55 °C	
Permissible ambient temperature (storage)	-25 °C ... +85 °C	
Permissible relative humidity	95 % (no condensation)	
Vibration / shock resistance	according to EN 60068-2-6 / EN 60068-2-27, EN 60068-2-29	
EMC resistance Burst / ESD	according to EN 61000-6-2 (EN 50082) / EN 61000-6-4 (EN 50081)	
Protection class	IP 20	
Installation position	variable	

BECKHOFF Fieldbus Components: Product Overview

## The Beckhoff Bus Terminal System

### Up to 64 Bus Terminals each having 2 I/O channels for each signal form

The Bus Terminal system is the universal interface between a fieldbus system and the sensor / actuator level. A unit consists of a Bus Coupler as the head station, and up to 64 electronic series terminals, the last one being an end terminal. For each technical signal form, terminals are available each having two I/O channels, and these can be mixed in any order. All the terminal types have the same mechanical construction, so that difficulties of planning and design are minimized. The height and depth match the dimensions of compact terminal boxes.

### Decentralized wiring of each I/O level

Fieldbus technology allows more compact forms of controller to be used. The I/O level does not have to be brought to the controller. The sensors and actuators can be wired decentrally, using minimum cable lengths. The controller can be installed at any location within the plant.



## **Industrial PCs as controllers**

The use of an Industrial PC as the controller means that the operating and observing element can be implemented in the controller's hardware. The controller can therefore be located at an operating panel, in a control room, or at some similar place. The Bus Terminals form the decentralized input/output level of the controller in the control cabinet and the subsidiary terminal boxes. The power sector of the plant is also controlled over the bus system in addition to the sensor/actuator level. The Bus Terminal replaces the conventional series terminal as the wiring level in the control cabinet. The control cabinet can have smaller dimensions.

## **Bus Couplers for all usual bus systems**

The BECKHOFF Bus Terminal system unites the advantages of a bus system with the possibilities of the compact series terminal. Bus Terminals can be driven within all the usual bus systems, thus reducing the controller parts count. The Bus Terminals then behave like conventional connections for that bus system. All the performance features of the particular bus system are supported.

## **Assembly on standardized C mounting rails**

The easy, space-saving, assembly on a standardized C-rail, and the direct wiring of actuators and sensors, without cross-connections between the terminals, standardizes the installation. The consistent labelling scheme also contributes.

The small physical size and the great flexibility of the Bus Terminal system allows it to be used wherever a series terminal is also used. Every type of connection, such as analog, digital, serial or the direct connection of sensors can be implemented.

## **Modularity**

The modular assembly of the terminal strip with Bus Terminals of various functions limits the number of unused channels to a maximum of one per function. The presence of two channels in one terminal is the optimum compromise of unused channels and the cost of each channel. The possibility of electrical isolation through potential feed terminals also helps to keep the number of unused channels low.

## **Display of the channel state**

The integrated LEDs show the state of the channel at a location close to the sensors and actuators.

## **K-Bus**

The K-Bus is the data path within a terminal strip. The K-Bus is led through from the Bus Coupler through all the terminals via six contacts on the terminals' side walls. The end terminal terminates the K-Bus. The user does not have to learn anything about the function of the K-Bus or about the internal workings of the terminals and the Bus Coupler. Many software tools that can be supplied make project planning, configuration and operation easy.

## **Potential feed terminals for isolated groups**

The operating voltage is passed on to following terminals via three power contacts. You can divide the terminal strip into arbitrary isolated groups by means of potential feed terminals. The potential feed terminals play no part in the control of the terminals, and can be inserted at any locations within the terminal strip.

Up to 64 terminals can be used within one terminal strip. This count does include potential feed terminals, but not the end terminal.

## **Bus Couplers for various fieldbus systems**

Various Bus Couplers can be used to couple the electronic terminal strip quickly and easily to different fieldbus systems. It is also possible to convert to another fieldbus system at a later time. The bus coupler performs all the monitoring and control tasks that are necessary for operation of the connected Bus Terminals. The operation and configuration of the Bus Terminals is carried out exclusively by the Bus Coupler. Nevertheless, the parameters that have been set are stored in each Bus Terminal, and are retained in the event of voltage drop-out. Fieldbus, K-Bus and I/O level are electrically isolated.

If the exchange of data over the fieldbus is prone to errors or fails for a period of time, register contents (such as counter states) are retained, digital outputs are cleared, and analog outputs take a value that can be configured for each output when commissioning. The default setting for analog outputs is 0 V or 0 mA. Digital outputs return in the inactive state. The timeout periods for the Bus Couplers correspond to the usual settings for the fieldbus system. When converting to a different bus system it is necessary to bear in mind the need to change the timeout periods if the bus cycle time is longer.

## **The interfaces**

A Bus Coupler has six different methods of connection. These interfaces are designed as plug connectors and as spring-loaded terminals.

BECKHOFF Fieldbus Components: PROFIBUS DP

# **PROFIBUS DP**

In PROFIBUS DP systems, a master (PLC, PC etc.) usually communicates with a large number of slaves (I/Os, drives etc.). Only the master may here actively access the bus (send telegrams on its own initiative), while a DP slave only sends telegrams when it is requested to do so by a master.

## **DP StartUp**

Before the master and slave can cyclically exchange data, the parameter and configuration data is transmitted from the master to the slaves during the DP StartUp phase. After the parameter and configuration data has been sent, the master interrogates the slave's diagnostic data until the slave indicates that it is ready for data exchange. Depending on the extent of the calculations that the slave must carry out after receiving the parameter and configuration data, it can take up to a few seconds before it is ready for data exchange. For this reason the slave possesses the following states:

### **Parameter data**

The parameter data is sent from the master to the slave in the SetPrmLock request telegram. The SetPrmLock response telegram does not contain any data, and therefore consists of a single byte, the short acknowledgement. The parameter data consists of DP parameters (e.g. the setting of the DP watchdog or checking the IdentNumber (unique to each DP device)), of DPV1-/DPV2 parameters and of application-specific parameters that only have to be transmitted once during the StartUp. If an error is found in the parameter data, this is indicated in the diagnostic data, and the slave either

remains in or enters the WAIT-PRM state.

## Configuration data

The configuration data is sent from the master to the slave in the ChkCfg request telegram. The ChkCfg response telegram does not contain any data, and therefore consists of a single byte, the short acknowledgement. The configuration data describes the assignment of the DP modules to the cyclic I/O data that is to be exchanged between the master and slave via the Data\_Exchange telegram in the cyclic data exchange phase. The sequence of the DP modules added to a slave in the DP configuration tool determines the sequence of the associated I/O data in the Data\_Exchange telegram.

## Diagnostic data

The diagnostic data is requested by the master using a SlaveDiag request telegram without any data. The slave replies with the diagnostic data in a SlaveDiag response telegram. The diagnostic data consists of the standard DP diagnostics (e.g. the state of the slave, the IdentNumber) and of application-specific diagnostic data.

## Cyclic data exchange

The heart of the PROFIBUS DP protocol is cyclic data exchange, during which the master carries out an exchange of I/O data with every slave during a PROFIBUS DP cycle. This involves the master sending the outputs to each slave with a DataExchange request telegram, while the slave replies with the inputs in a DataExchange response telegram. This means that all the output and/or input data is transmitted in one telegram, in which the DP configuration (the sequence of DP modules) specifies the assignment of the output and/or input data to the slave's actual process data.

## Diagnosis during cyclic data exchange

A slave can send a diagnostics signal to the master during cyclic data exchange. In this case, the slave sets a flag in the DataExchange response telegram, whereby the master recognises that there is new diagnostic data in the slave. It then fetches that data in the SlaveDiag telegram. This means that diagnostic data is not transmitted to the controller with the cyclic I/O data in real-time, but is always at least one DP cycle later.

## Synchronisation with Sync and Freeze

The Sync and Freeze commands in the GlobalControl request telegram (broadcast telegram) allow the master to synchronise the activation of the outputs (Sync) or the reading of the inputs (Freeze) in a number of slaves. When the Sync command is used, the slaves are first switched into Sync mode (a process that is acknowledged in the diagnostic data). The I/O data is then exchanged sequentially with the slaves in the DataExchange telegram. Transmitting the Sync command in the GlobalControl telegram then has the effect of causing the slaves to generate the most recently received outputs. In Freeze operation a Freeze command is first sent in the GlobalControl telegram, in response to which all the slaves latch their inputs. These are then fetched sequentially by the master in the DataExchange telegram.

## States in the master

The master distinguishes between the CLEAR state (all outputs are set to the Fail\_Safe value) and the OPERATE state (all outputs have the process value). The Master is usually switched into the CLEAR mode when, for instance, the PLC enters STOP.

## Class 1 and Class 2 DP Masters

The Class 1 master refers to the controller that carries out cyclic I/O data exchange with the slaves, while a Class 2 master is a B&B device that generally only has read access to the slaves' I/O data.

BECKHOFF Fieldbus Components: PROFIBUS DP

## PROFIBUS DPV1

PROFIBUS DPV1 refers primarily to the acyclic read and write telegrams, with which data sets in the slave are acyclically accessed. A distinction between a Class 1 and a Class 2 master is also made for DPV1. The difference between acyclic Class 1 (C1) and Class 2 (C2) connections is that the acyclic C1 connection is established during the DP StartUp phase of cyclic DP operation. Once the slave has reached the WAIT-CFG state it is possible for acyclic DPV1-C1 read and write telegrams to be sent from the master to the slave, whereas the C2 connection is established separately, independently of the cyclic DP connection. This is usually carried out by a second (C2) master so that, for instance, a manufacturer-specific project configuration and diagnostic tool can access the slave's data.

When two masters are used, however, it must always be borne in mind that these share bus access (a token is exchanged), so that time relationships are less favourable than in the case of a single master system.

BECKHOFF Fieldbus Components: Mounting and Wiring

## Dimensions

The system of the Beckhoff Bus Terminals is characterized by low physical volume and high modularity. When planning a project it must be assumed that at least one Bus Coupler and a number of Bus Terminals will be used. The mechanical dimensions of the Bus Couplers are independent of the fieldbus system.

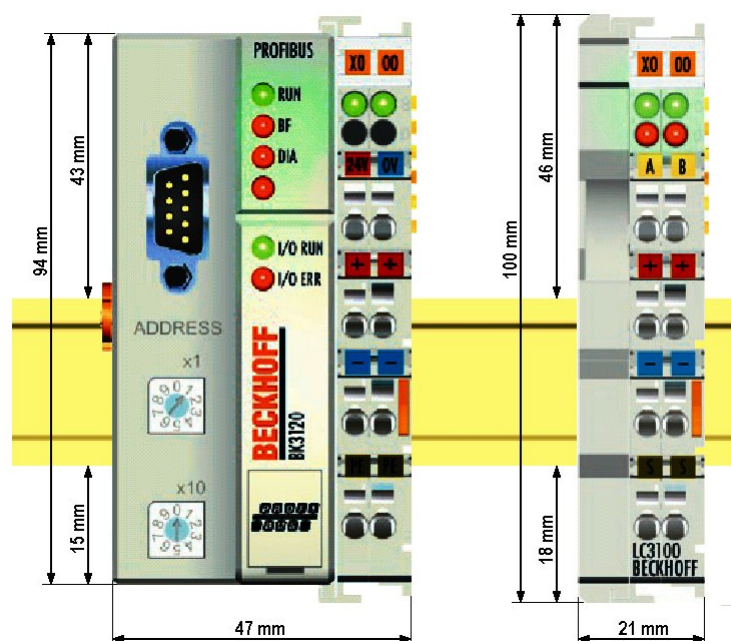

The total width in practical cases is composed of the width of the Bus Coupler with the KL9010 Bus End Terminal and the width of the Bus Terminals in use. Depending on function, the Bus Terminals are 12 or 24 mm wide. The front wiring increases the total height of 68mm by about 5 to 10 mm, depending on the wire thickness.

Mechanical data	BK30x0, BK35x0, KL3110, BK3120	BK3150	LC3100
Material	polycarbonate, polyamide (PA 6.6)		
Dimensions (W x H x D)	50 mm x 100 mm x 68 mm	44 mm x 100 mm x 68 mm	21 mm x 100 mm x 68 mm
Mounting	on 35 mm C-rail conforming to EN50022 with lock		
Side by side mount. by means of	double slot and key connection		
Marking	standard terminal block marking and plain language side (8 mm x 47 mm, not BK3150)		

BECKHOFF Fieldbus Components: Mounting and Wiring

## Installation

The Bus Coupler and all the Bus Terminals can be clipped, with a light press, onto a 35 mm mounting rail. A locking mechanism prevents the individual housings from being pulled off again. For removal from the mounting rail the orange colored tension strap releases the latching mechanism, allowing the housing to be pulled off the rail without any force.

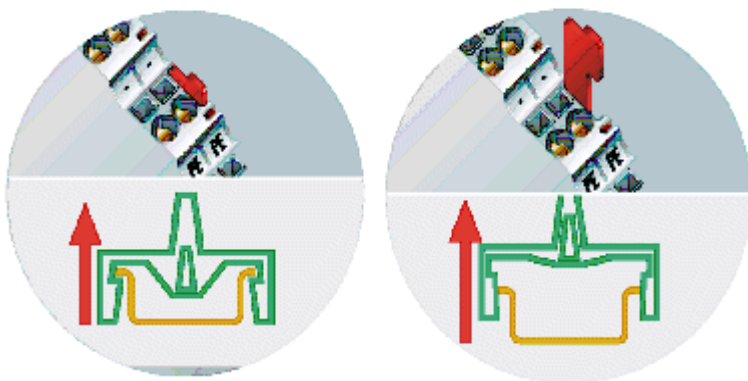

Up to 64 Bus Terminals can be attached to the Bus Coupler on the right hand side. When plugging the components together, be sure to assemble the housings with groove and tongue against each other. A properly working connection can not be made by pushing the housings together on the mounting rail. When correctly assembled, no significant gap can be seen between the attached housings.

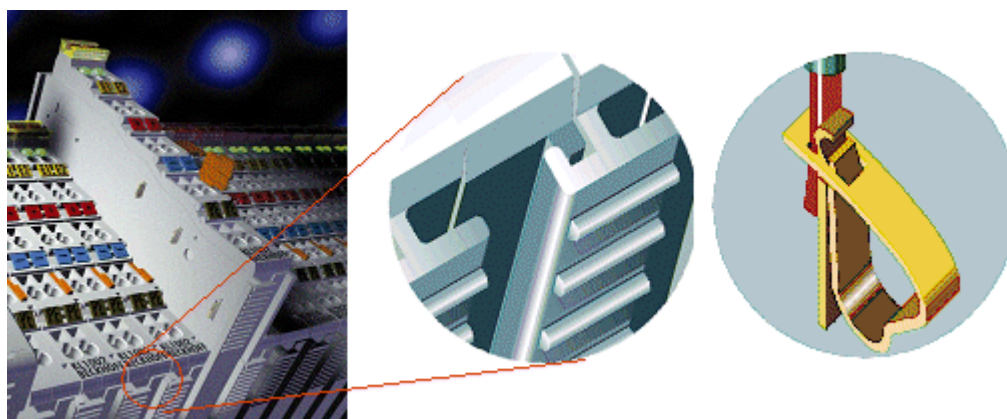

### Warning

Insertion and removal of Bus Terminals is only permitted when switched off. The electronics in the Bus Terminals and in the Bus Coupler are protected to a large measure against damage, but incorrect function and damage cannot be ruled out if they are plugged in under power.

The right hand part of the Bus Coupler can be compared to a Bus Terminal. Eight connections at the top enable the connection with solid or fine wires from 0.08 mm<sup>2</sup> to 2.5 mm<sup>2</sup>. The connection is implemented with the aid of a spring device. The spring-loaded terminal is opened with a screwdriver or rod, by exerting gentle pressure in the opening above the terminal. The wire can be inserted into the terminal without any force. The terminal closes automatically when the pressure is released, holding the wire securely and permanently.

BECKHOFF Fieldbus Components: Mounting and Wiring

## Potential Groups, Insulation Testing and PE

## Potential groups

The Beckhoff Bus Terminals stations usually have three different potential groups:

- The fieldbus interface is electrically isolated (except for individual Low Cost couplers) and forms the first potential group
- Bus Coupler / Bus Terminal Controller logic, K-Bus and terminal logic form a second galvanically separated potential group
- The inputs and outputs are supplied via the power contacts and form further potential groups.

Groups of I/O terminals can be consolidated to further potential groups via potential supply terminals or separation terminals.

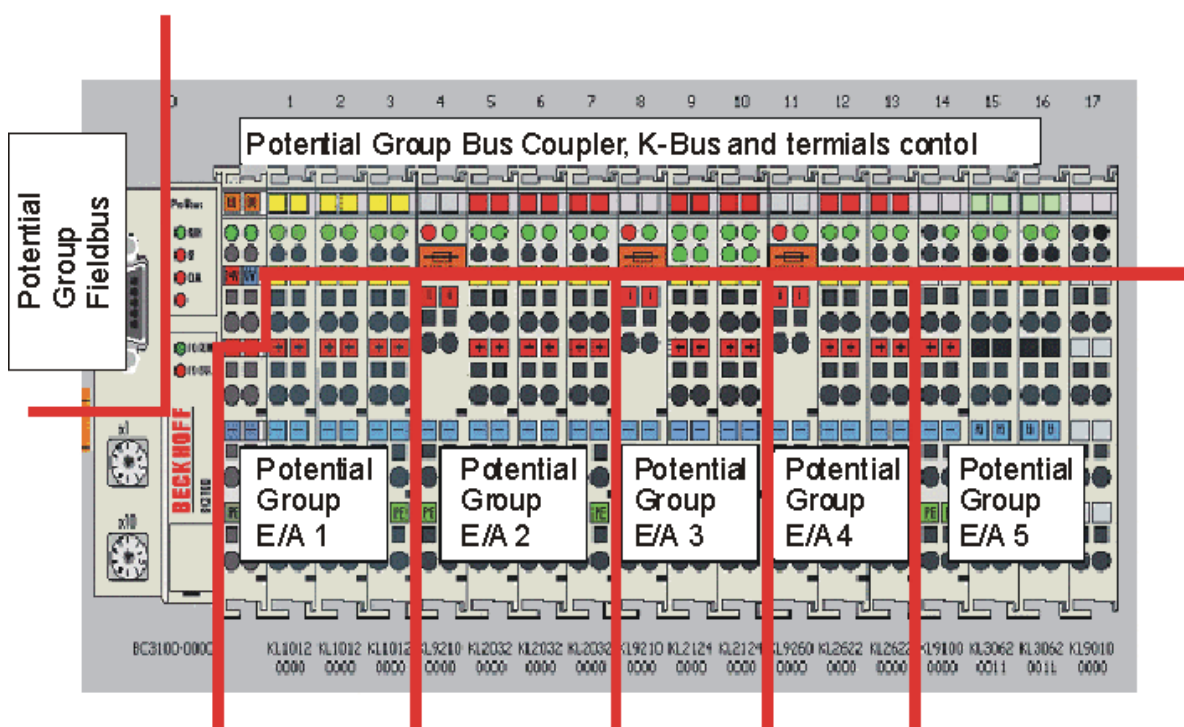

## Insulation testing

The connection between the Bus Coupler / Bus Terminal Controller and the Bus Terminals is automatically realized by pushing the components together. The transfer of the data and the supply voltage for the intelligent electronics in the Bus Terminals is performed by the K-Bus. The supply of the field electronics is performed through the power contacts. Plugging together the power contacts creates a supply rail. Since some Bus Terminals (e.g. analog Bus Terminals or 4-channel digital Bus Terminals) are not looped through these power contacts (or not completely) the Bus Terminal contact assignments must be considered.

The potential feed terminals interrupt the power contacts, and represent the start of a new supply rail. The Bus Coupler / Bus Terminal Controller can also be made use of to feed the power contacts.

## PE power contacts

The power contact labelled PE can be used as a protective earth. For safety reasons this contact mates first when plugging together, and can ground short-circuit currents of up to 125 A.

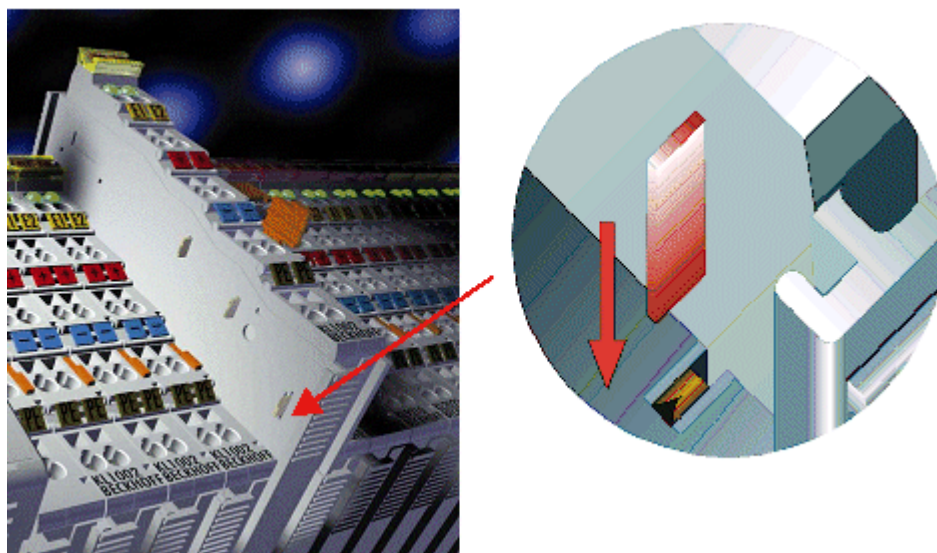

It should be noted that, for reasons of electromagnetic compatibility, the PE contacts are capacitively coupled to the mounting rail. This can both lead to misleading results and to damaging the terminal during insulation testing (e.g. breakdown of the insulation from a 230 V power consuming device to the PE conductor). The PE conductor to the Bus Coupler / Bus Terminal Controller must be disconnected for the insulation testing. In order to uncouple further feed locations for the purposes of testing, the feed terminals can be pulled at least 10 mm out from the connected group of other terminals. In that case, the PE conductors do not have to be disconnected.

The PE power contact must not be used for other potentials.

BECKHOFF Fieldbus Components: Mounting and Wiring

## Power Supply

### Bus Coupler / Bus Terminal Controller and Bus Terminal Supply (Us)

#### **BKxx00, BKxx10, BKxx20 and LCxxxx**

The Bus Coupler / Bus Terminal Controller require a 24 V<sub>DC</sub> supply for their operation.

The connection is made by means of the upper spring-loaded terminals labeled 24 V and 0 V. This supply voltage feeds the Bus Coupler / Bus Terminal Controller electronics and, over the K-Bus, the electronics of the Bus Terminals. It is electrically separated from the potential of the field level.



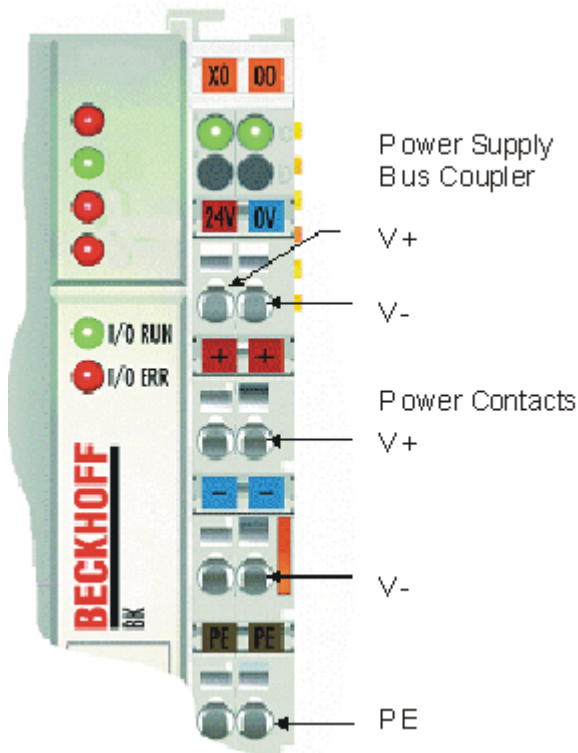

### BKxx50 and BKxx51

The Bus Coupler / Bus Terminal Controller require a 24 V<sub>DC</sub> supply for their operation. To meet the UL requirements use 4 A fuse or class 2 power supply!

The connection is made by means of the upper spring-loaded terminals labeled *Us* and *GNDs*. This supply voltage feeds the Bus Coupler / Bus Terminal Controller electronics and, over the K-Bus, the electronics of the Bus Terminals. It is electrically separated from the potential of the field level.

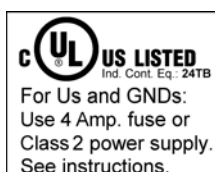
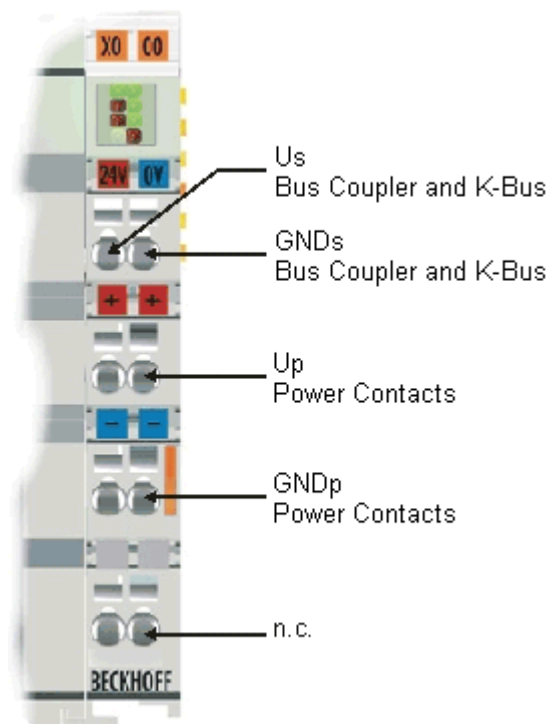

### UL requirements

For the compliance of the UL requirements Us should only be supplied



- by a 24 V<sub>DC</sub> supply voltage, supplied by an isolating source and protected by means of a fuse (in accordance with UL248), rated maximum 4 Amp.

- by a 24 V<sub>DC</sub> power source, that has to satisfy *NEC class 2*.

A *NEC class 2* power supply shall not be connected in series or parallel with another (class 2) power source!



To meet the UL requirements, Us must not be connected to unlimited power sources!

## Power contacts supply (Up)

The bottom six connections with spring-loaded terminals can be used to feed the supply for the peripherals. The spring-loaded terminals are joined in pairs to a power contact. The feed for the power contacts has no connection to the voltage supply for the Bus Coupler / Bus Terminal Controller.

The spring-loaded terminals are designed for wires with cross-sections between 0.08 mm<sup>2</sup> and 2.5 mm<sup>2</sup>.

The assignment in pairs and the electrical connection between feed terminal contacts allows the connection wires to be looped through to various terminal points. The current drawn from the power contact must not exceed 10 A for long periods. The current carrying capacity between two spring-loaded terminals is identical to that of the connecting wires.

## Power contacts

On the right hand face of the Bus Coupler / Bus Terminal Controller there are three spring contacts for the power contact connections. The spring contacts are hidden in slots so that they can not be accidentally touched. By attaching a Bus Terminal the blade contacts on the left hand side of the Bus Terminal are connected to the spring contacts. The tongue and groove guides on the top and bottom of the Bus Coupler / Bus Terminal Controller and of the Bus Terminals enables that the power contacts mate securely.

## Configuration and Programming Interface

The Bus Coupler / Bus Terminal Controller have an RS232 interface at the bottom of the front face. The miniature connector can be joined to a PC and the KS2000 configuration software with the aid of a connecting cable. The interface permits the Bus Terminals to be configured, for example adjusting the amplification factors of the analog channels. The interface can also be used to change the assignments of the bus terminal data to the process image in the Bus Coupler. The functionality of the configuration interface can also be reached via the fieldbus using string communication facility.

## Electrical isolation

The Bus Coupler / Bus Terminal Controller operate by means of three independent potential groups. The supply voltage feeds the K-Bus electronics and the K-Bus itself. The supply voltage is also used to generate the operating voltage for the fieldbus interface.

Remark: All the Bus Terminals are electrically isolated from the K-Bus. The K-Bus is thus

electrically isolated from everything else.

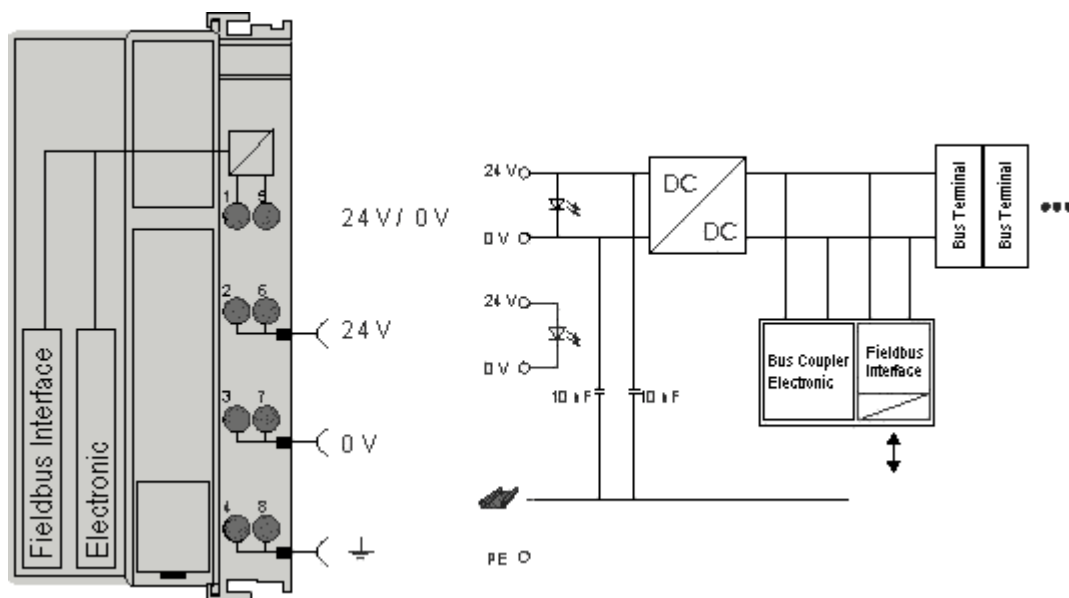

BECKHOFF Fieldbus Components: Mounting and Wiring

## PROFIBUS Connection

### M12 circular connector

The M12 socket is inverse coded, and has five pins. Pin 1 is  $5\text{ V}_{\text{DC}}$  and 3 is GND for the active termination resistor. These must never be misused for other functions, as this can lead to destruction of the device. Pin 2 and pin 4 are the Profibus signals. These must never be swapped over, as this will prevent communication. Pin 5 is the shield, and this is capacitatively coupled to the Fieldbus Box chassis.

#### M12 socket pin assignment

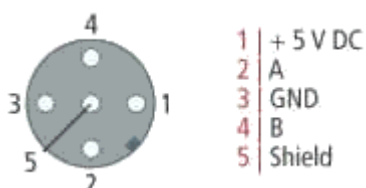

### Nine pole D-Sub

Pin 6 is  $5\text{ V}_{\text{DC}}$  and Pin 5 is GND for the active termination resistor. These must never be misused for other functions, as this can lead to destruction of the device. Pin 3 and pin 8 are the Profibus signals. These must never be swapped over, as this will prevent communication. Shield is connected to the D-Sub housing that is coupled with low-resistance to the mounting rail.

#### D-Sub socket pin assignment

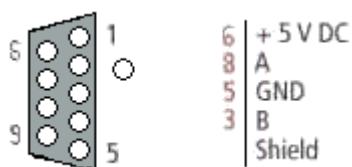

## Profibus conductor colors

Profibus conductors	M12	D-Sub
B red	Pin 4	Pin 3
A green	Pin 2	Pin 8

## Connection of FieldbusBox modules

The connection of the Fieldbus Box modules is done direct or via a T-piece (or Y-piece).

The B318 series does have a male and female connector, that means no external T-piece is required. The supply voltage (+5V<sub>DC</sub>) for the termination resistor is only supplied via the female M12 connector. The termination resistor ZS1000-1610 is only available with male connector, therefore the incoming PROFIBUS line should end in a female connector.

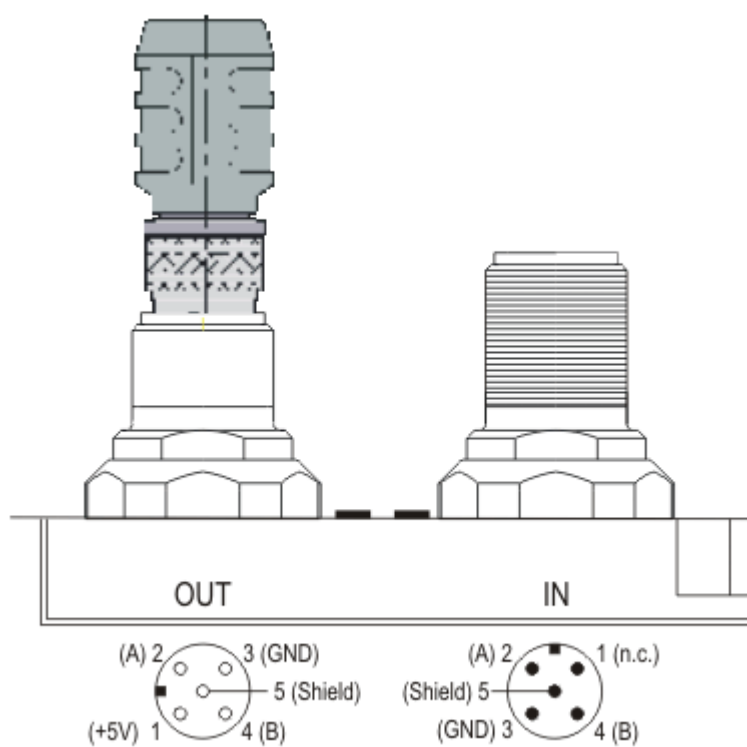

Two T-pieces are available:

- ZS1031-2600 with +5VDC on male and female connector for the termination resistor
- ZS1031-2610 with +5VDC only on the female connector

# PROFIBUS Cabling

Physical aspects of the data transmission are defined in the Profibus standard (see Profibus layer 1: Physical Layer).

The types of area where a fieldbus system can be used is largely determined by the choice of the transmission medium and the physical bus interface. In addition to the requirements for transmission security, the expense and work involved in acquiring and installing the bus cable is of crucial significance. The Profibus standard therefore allows for a variety of implementations of the transmission technology while retaining a uniform bus protocol.

## Cable-based transmission

This version, which accords with the American EIA RS-485 standard, was specified as a basic version for applications in production engineering, building management and drive technology. A twisted copper cable with one pair of conductors is used. Depending on the intended application area (EMC aspects should be considered) the screening may be omitted.

Two types of conductor are available, with differing maximum conductor lengths (see the RS-485 table).

### RS485 - Fundamental properties

<b>RS-485 transmission according to the Profibus standard</b>	
Network topology	Linear bus, active bus terminator at both ends, stubs are possible.
Medium	Screened twisted cable, screening may be omitted, depending upon the environmental conditions (EMC).
Number of stations	32 stations in each segment with no repeater. Can be extended to 127 stations with repeater
Max. bus length without repeater	100 m at 12 MBit/s 200 m at 1500 KBit/s, up to 1.2 km at 93.75 KBit/s
Max. bus length with repeater	Line amplifiers, or repeaters, can increase the bus length up to 10 km. The number of repeaters possible is at least 3, and, depending on the manufacturer, may be up to 10.
Transmission speed (adjustable in steps)	9.6 kBit/s; 19.2 kBit/s; 93.75 kBit/s; 187.5 kBit/s; 500 kBit/s; 1500 kBit/s; 12 MBit/s
Plug connector	9-pin D-Sub connector for IP20 M12 round connector for IP65/67

## Cabling for Profibus DP and Profibus FMS

Note the special requirements on the data cable for baud rates greater than 1.5 MBaud. The correct cable is a basic requirement for correct operation of the bus system. If a simple 1.5 Mbaud cable is used, reflections and excessive attenuation can lead to some surprising phenomena. It is possible, for instance, for a connected Profibus station not to achieve a connection, but for it to be included again when the neighboring station is disconnected. Or there may be transmission errors when a specific bit pattern is transmitted. The result of this can be that when the equipment is not operating, Profibus works without faults, but that there are apparently random bus errors after start-up. Reducing the baud rate (< 93,75 kBaud) corrects this faulty behavior.

If reducing the baud rate does not correct the error, then in many cases this can indicate a wiring

fault. The two data lines may be crossed over at one or more connectors, or the termination resistors may not be active, or they may be active at the wrong locations.



**Note**

Installation is made a great deal more straightforward if pre-assembled cables from BECKHOFF are used! Wiring errors are avoided, and commissioning is more rapidly completed. The BECKHOFF range includes fieldbus cables, power supply cables, sensor cables and accessories such as terminating resistors and T-pieces. Connectors and cables for field assembly are nevertheless also available.

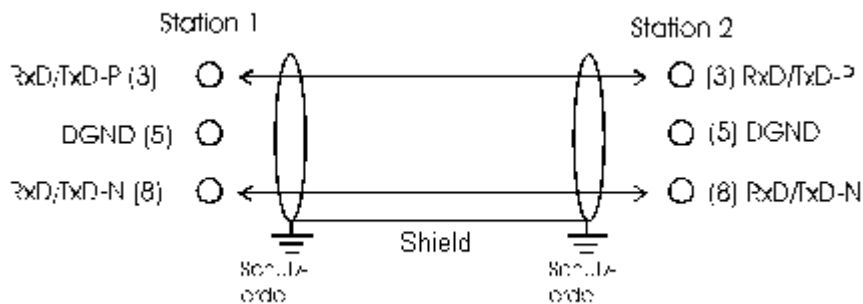

**Note**

In systems with more than two stations all devices are wired in parallel. It is essential that the bus cables are terminated with resistors at the conductor ends in order to avoid reflections and associated transmission problems.

## Distances

The bus cable is specified in EN 50170. This yields the following lengths for a bus segment.

Baud rate in kbits/sec	9.6	19.2	93.75	187.5	500	1500	12000
Cable length in m	1200	1200	1200	1000	400	200	100

Stubs up to 1500 kbaud <6.6 m; at 12 Mbaud stub segments should not be used.

## Bus segments

A bus segment consists of at most 32 devices. 126 devices are permitted in a Profibus network. Repeaters are required to refresh the signal in order to achieve this number. Each repeater is counted as one device.

IP-Link is the subsidiary bus system for Fieldbus Boxes, whose topology is a ring structure. There is an IP master in the coupler modules (IP230x-Bxxx or IP230x-Cxxx) to which up to 120 extension modules (IExxxx) may be connected. The distance between two modules may not exceed 5 m. When planning and installing the modules, remember that because of the ring structure the IP-Link master must be connected again to the last module.

## Installation guidelines

When assembling the modules and laying the cables, observe the technical guidelines provided by the Profibus User Organization (Profibus Nutzerorganisation e.V.) for Profibus DP/FMS (see [www.profibus.com](http://www.profibus.com)).

## Checking the Profibus wiring

A Profibus cable (or a cable segment when using repeaters) can be checked with a few simple resistance measurements. The cable should meanwhile be removed from all stations:

1. Resistance between A and B at the start of the lead: approx. 110 Ohm
2. Resistance between A and B at the end of the lead: approx. 110 Ohm
3. Resistance between A at the start and A at the end of the lead: approx. 0 Ohm
4. Resistance between B at the start and B at the end of the lead: approx. 0 Ohm
5. Resistance between screen at the start and screen at the end of the lead: approx. 0 Ohm

If these measurements are successful, the cable is okay. If, in spite of this, bus malfunctions still occur, this is usually a result of EMC interference. Observe the installation notes from the Profibus User Organization ([www.profibus.com](http://www.profibus.com)).

BECKHOFF Fieldbus Components: Parameterization and Commissioning

## Start-up Behaviour of the Bus Coupler

Immediately after being switched on, the Bus Coupler checks, in the course of a self test, all the functions of its components and the communication on the K-Bus. The red I/O LED blinks while this is happening. After completion of the self-test, the Bus Coupler starts to test the attached Bus Terminals (the *Bus Terminal Test*), and reads in the configuration. The Bus Terminal configuration is used to generate an internal structure list, which is not accessible from outside. In case of an error, the Bus Coupler enters the STOP state. Once the start-up has completed without error, the Bus Coupler enters the *fieldbus start* state.

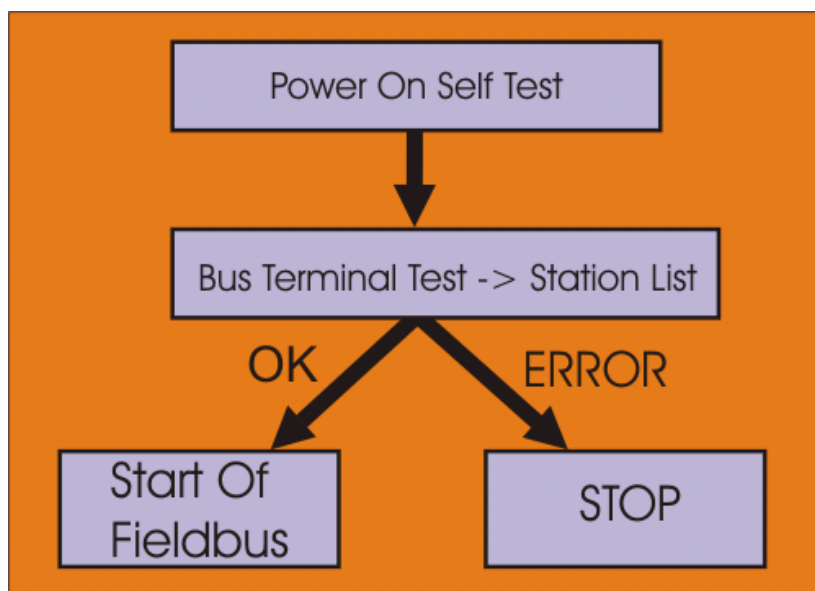

The Bus Coupler can be made to enter the normal operating state by switching it on again once the fault has been rectified.

BECKHOFF Fieldbus Components: Parameterisation and Commissioning

# The Bus Coupler's UserPrmData

The following settings can be made in the Bus Coupler's UserPrmData. So that a more easily understood [GSD file](#) is obtained in 90% of applications, some of the settings are only contained in text form in the [extended GSD file](#), and these are indicated in the last column by *Extended*. The standard settings are contained both in the standard and the [extended GSD file](#).

Byte	Bit	Value	Description	GSD file
0	7	0 <sub>bin</sub>	MSAC_C1 connection is not active (default)	Standard
		1 <sub>bin</sub>	MSAC_C1 connection is active (see <a href="#">DPV1</a> )	
1	0	0 <sub>bin</sub>	CfgData checking is active (default)	Extended
		1 <sub>bin</sub>	CfgData checking deactivated (see <a href="#">Deactivating the CfgData checking</a> )	
2	3	0 <sub>bin</sub>	Diagnostic data is transferred in a form compatible with the BK3100	Extended
		1 <sub>bin</sub>	Diagnostic data is transferred in a form compatible with DPV1 (default)	
3	3	0 <sub>bin</sub>	Multi-configuration mode is not active (default)	Extended
		1 <sub>bin</sub>	Multi-configuration mode is active (see <a href="#">Multi-configuration mode</a> )	
3	4	0 <sub>bin</sub>	K-Bus cycle counter is not active (default)	Extended
		1 <sub>bin</sub>	K-Bus cycle counter is active (see <a href="#">K-Bus cycle</a> )	
3	5	0 <sub>bin</sub>	Dummy output byte not active (default)	Extended
		1 <sub>bin</sub>	Dummy output byte is active (see <a href="#">K-Bus cycle</a> )	
3	6	0 <sub>bin</sub>	In multi-configuration mode, the coupler sets the <i>Stat_Diag</i> bit in the diagnostic data if the configuration is not consistent, and does not yet enter data exchange (default).	Extended
		1 <sub>bin</sub>	In multi-configuration mode the coupler also enters data exchange even when the configuration is not consistent, although K-Bus cycles are not yet executed (see <a href="#">Multi-configuration mode</a> )	
5	0	0 <sub>bin</sub>	2-byte PLC interface not activated (default)	Extended
		1 <sub>bin</sub>	2-byte PLC interface is active (see <a href="#">2-byte PLC interface</a> )	
7	0	0 <sub>bin</sub>	Response to K-Bus error: manual K-Bus reset (default) (see <a href="#">K-Bus interruption</a> )	Standard
		1 <sub>bin</sub>	Response to K-Bus error: automatic K-Bus reset	
7	1	0 <sub>bin</sub>	Terminal diagnosis is not active (default) (see <a href="#">Terminal diagnosis</a> )	Standard
		1 <sub>bin</sub>	Terminal diagnosis is active	
7	4	0 <sub>bin</sub>	Diagnostic data for digital terminals included in process image (default) (see <a href="#">Terminal diagnosis</a> )	Standard
		1 <sub>bin</sub>	Diagnostic data of digital terminals not in the process image (default)	
			Analog modules are mapped in compact form (only showing the input and/or output user data) (this is the	



9	2	$0_{bin}$	default, only relevant when CfgData checking has been deactivated, otherwise the terminals are set by means of the CfgData) (see <a href="#">Deactivation of CfgData checking</a> )	Extended
		$1_{bin}$	Analog modules are mapped in complex form (with control/status for register access and with the same data length in inputs and outputs) (only relevant when CfgData checking has been deactivated, otherwise the terminals are set by means of the CfgData)	
9	3	$0_{bin}$	Representation in INTEL format	Standard
		$1_{bin}$	Representation in Motorola format (default)	
9	4	$0_{bin}$	K-Bus mode slow FreeRun (default) (see <a href="#">K-Bus cycle</a> )	Standard
		$1_{bin}$	K-Bus mode fast FreeRun	
9	5	$0_{bin}$	WORD alignment inactive (default)	Extended
		$1_{bin}$	WORD alignment active (see <a href="#">WORD alignment</a> )	
9	6	$0_{bin}$	K-Bus mode is synchronous (see <a href="#">K-Bus cycle</a> )	Standard
		$1_{bin}$	K-Bus mode FreeRun (default)	
10	0-1	$00_{bin}$	Reaction to PROFIBUS error: K-Bus cycle is abandoned (default, digital outputs become 0, complex outputs are set to a configured substitute value) (see Reaction to <a href="#">PROFIBUS errors</a> )	Standard
		$01_{bin}$	Reaction to PROFIBUS error: K-Bus outputs become 0	
		$10_{bin}$	Reaction to PROFIBUS error: K-Bus outputs remain unchanged	
10	2-3	$00_{bin}$	Reaction to K-Bus error: DP data exchange is abandoned (default) (see <a href="#">K-Bus interruption</a> )	Standard
		$01_{bin}$	Reaction to K-Bus error: DP inputs set to 0	
		$10_{bin}$	Reaction to K-Bus error: DP inputs remain unchanged	
11	3-6	X	Maximum length of the diagnostic data. Allowed values: 16, 24, 32, 40, 48, 56, 64 (see <a href="#">Terminal diagnosis</a> )	Extended
12	0-1	$0_{bin}$	If K-Bus mode is synchronous: standard synchronous mode (default) (see <a href="#">K-Bus cycle</a> )	Extended
		$01_{bin}$	If K-Bus mode is synchronous: synchronous mode with optimised input update (one cycle)	
		$10_{bin}$	If K-Bus mode is synchronous: synchronous mode with optimised input update (two cycles)	
12	4-7	$0_{bin}$	Maximum DP buffer lengths not changed	Extended
12	4-7	15	The maximum DP buffer lengths are changed using the values from UserPrmData 37-40 (see <a href="#">Multi-configuration mode</a> )	Extended
13	0-7	X	Delay time (in $\mu s$ ) high byte (see <a href="#">K-Bus cycle</a> )	Extended
14	0-7	X	Delay time (in $\mu s$ ) low byte (see <a href="#">K-Bus cycle</a> )	Extended
15-30	0-7	X	Assignment of Bus Terminals 1 to 64 (see <a href="#">Multi-configuration mode</a> )	Extended
31-36	0-7	-	reserved	Extended

37	0-7	X	Maximum length of the input data (see <a href="#">Multi-configuration mode</a> )	Extended
38	0-7	X	Maximum length of the output data (see <a href="#">Multi-configuration mode</a> )	Extended
39	0-7	X	Maximum length of the diagnostic data (see <a href="#">Multi-configuration mode</a> )	Extended
40	0-7	X	Maximum length of the configuration data (see <a href="#">Multi-configuration mode</a> )	Extended
41-56	0-7	X	Assignment of terminals 65 to 128 (see <a href="#">Multi-configuration mode</a> )	Extended

BECKHOFF Fieldbus Components: Parameterisation and Commissioning

## Technical Data - Summary

### Technical data

Description	BK3010	BK3110	BK3120	BK3150	BK3500	BK3520	LC3100	BC3100
Number of Bus Terminals	64	64	255	255	64	255	64	64
Baud rate [Mbaud]	1.5	12	12	12	1.5	12	12	12
Physical basis	RS 485	RS 485	RS 485	RS 485	Optical fibres	Optical fibres	RS 485	RS 485
<i>UserPrm Data</i>								
DPV1 Services	x	x	x	x	x	x	x	x
Multi-configuration mode	x	x	x	x	x	x	x	
Word Align			x	x	x	x		
Byte oriented Bus Terminals			x	x	x	x		x
<i>Distributed control</i>								
PLC IEC 61131-3								x

BECKHOFF Fieldbus Components: Parameterisation and Commissioning

## Configuration - CfgData

The CfgData is generated from the modules inserted in the DP configuration tool. When modules are added, the following rules are to be observed:

Sequence of DP modules to be added in the DP configuration tool
<a href="#">Modules for the coupler's functions</a>
<a href="#">Complex function modules</a>

## Digital function modules

For TwinCAT applications, these rules are followed by the TwinCAT system manager. It adds the terminals or IE modules in the sequence in which they are plugged in, and the modules for functions are added automatically if the corresponding function is activated in the [UserPrmData](#).

BECKHOFF Fieldbus Components: Parameterisation and Commissioning

# Configuration of the Coupler Modules

The DP modules for the following Bus Coupler functions are to be added first in the DP configuration tool if the associated function is activated (if the function is not activated, the corresponding DP module is not to be added):

Function module	Activation of the function
2-byte PLC interface	The 2-byte PLC interface is activated via the <a href="#">UserPrmData</a> (byte 5, bit 0). By default it is not active.
K-Bus cycle counter	The <a href="#">K-Bus cycle counter</a> is activated via the <a href="#">UserPrmData</a> (byte 3, bit 3). By default it is not active.
Dummy output byte	The <a href="#">dummy output byte</a> is activated via the <a href="#">UserPrmData</a> (byte 3, bit 5). By default it is not active.

BECKHOFF Fieldbus Components: Parameterisation and Commissioning

# Configuration of Complex Modules

After the DP modules for the activated functions of the Bus Coupler have been added to the Bus Coupler in the DP configuration tool, the next step is for the complex terminals (KL15xx, KL25xx, KL3xxx, KL4xxx, KL5xxx, KL6xxx, KL8xxx) to be added in the sequence in which they are plugged in, regardless of whether digital terminals are plugged in between the complex terminals, or of how many there may be:

Complex function module	Description	Associated CfgData (as hex code)
KL1501	KL1501	0xB4 (in GSD file)
		0xB5 (alternatively)
		0xF2 (alternatively)
KL2502	KL2502	0xB5 (in GSD file)
		0xB2, 0xB2 (alternatively)
		0xF2 (alternatively)
KL2521	KL2521	0xB2 (in GSD file)
		0xF1 (alternatively)

KL3351 compact	KL3351 - only the 16 bit input value is transmitted	0x51 (in GSD file) 0x50, 0x50 (alternatively)
KL3351 complex	KL3351 - 24 bits of input/output are transmitted, so that access can be had to the terminal's registers in addition to transmission of the 16 bit input value	0xB5 (in GSD file) 0xB2, 0xB2 (alternatively) 0xF2 (alternatively)
KL3361	KL3361	0xFB (in GSD file)
KL3xx2 compact	All KL3xx2 - only the 16 bit input value of each channel is transmitted	0x51 (in GSD file) 0x50, 0x50 (alternatively)
KL3xx2 complex	Old KL3xx2 - 24 bits of input/output are transmitted for each channel, so that access can be had to the terminal's registers in addition to transmission of the 16 bit input value	0xB5 (in GSD file) 0xB2, 0xB2 (alternatively) 0xF2 (alternatively)
KL3xx4 compact	All KL3xx4 - only the 16 bit input value of each channel is transmitted	0x53 (in GSD file) 0x51, 0x51 (alternatively) 0x50, 0x50, 0x50, 0x50 (alternatively)
KL3xx4 complex	Old KL3xx4 - 24 bits of input/output are transmitted for each channel, so that access can be had to the terminal's registers in addition to transmission of the 16 bit input value	0xBB (in GSD file) 0xB5, 0xB5 (alternatively) 0xB2, 0xB2, 0xB2, 0xB2 (alternatively) 0xF5 (alternatively)
KL4xx2 compact	All KL4xx2 - only the 16 bit output value of each channel is transmitted	0x61 (in GSD file) 0x60, 0x60 (alternatively)
KL4xx2 complex	Old KL4xx2 - 24 bits of input/output are transmitted for each channel, so that access can be had to the terminal's registers in addition to transmission of the 16 bit input value	0xB5 (in GSD file) 0xB2, 0xB2 (alternatively) 0xF2 (alternatively)
KL4xx4 compact	All KL4xx4 - only the 16 bit output value of each channel is transmitted	0x63 (in GSD file) 0x61, 0x61 (alternatively) 0x60, 0x60, 0x60, 0x60 (alternatively)
KL4xx4 complex	Old KL4xx4 - 24 bits of input/output are transmitted for each channel, so that access can be had to the terminal's registers in addition to transmission of the 16 bit input value	0xBB (in GSD file) 0xB5, 0xB5 (alternatively) 0xB2, 0xB2, 0xB2, 0xB2 (alternatively) 0xF5 (alternatively)
KL5001 compact	KL5001 - only the 32 bit input value is transmitted	0x93 (in GSD file) 0xD1 (alternatively)
KL5001 complex	KL5001 - 40 bits of input/output are transmitted, so that access can be had to the terminal's registers in addition to transmission of the 40 bit input value	0xB4 (in GSD file) 0xB5 (alternatively) 0xF2 (alternatively)
KL5051	KL5051	0xB5 (in GSD file) 0xF2 (alternatively)
KL5101	KL5101	0xB5 (in GSD file) 0xF2 (alternatively)
KL5111	KL5111	0xB5 (in GSD file) 0xF2 (alternatively)
KL5121	KL5121	0xB5 (in GSD file) 0xF2 (alternatively)

KL5151	KL5151	0xB5 (in GSD file)
		0xF2 (alternatively)
KL5302	KL5302	0xB5 (in GSD file)
		0xF2 (alternatively)
KL6001	KL6001	0xB5 (in GSD file)
		0xF2 (alternatively)
KL6011	KL6011	0xB5 (in GSD file)
		0xF2 (alternatively)
KL6021	KL6021	0xB5 (in GSD file)
		0xF2 (alternatively)
KL6051 compact	KL6051 - only the 32 input bits and 32 output bits are transmitted	0xB3 (in GSD file)
		0xF1 (alternatively)
KL6051 complex	KL6051 - 48 input bits and 48 output bits are transmitted, so that in addition to the 40 input bits and the 40 output bits, access can also be had to the terminal's registers	0xB5 (in GSD file)
		0xF2 (alternatively)
KL6061	KL6061	0xBA (in GSD file)
		0xF5 (alternatively)
KL6201 (PAB 6)	KL6201 - 6 bytes input and output process data is transferred (ASI slaves 1-11)	0x35 (in GSD file)
KL6201 (PRM PAB 6)	KL6201 - 6 bytes parameter interface and 6 bytes input and output process data is transferred (ASI slaves 1-11)	0xF2,0x35 (in GSD file)
KL6201 (PAB 16)	KL6201 - 16 bytes input and output process data is transferred (ASI slaves 1-31)	0x3F (in GSD file)
KL6201 (PRM PAB 16)	KL6201 - 6 bytes parameter interface and 16 bytes input and output process data is transferred (ASI slaves 1-31)	0xF2,0x3F (in GSD file)
KL6801	KL6801	0xB5 (in GSD file)
		0xF2 (alternatively)
KL8001	KL8001	0xBB (in GSD file)
		0xF5 (alternatively)

BECKHOFF Fieldbus Components: Parameterisation and Commissioning

## Configuration of Digital Modules

After the DP modules for the activated functions of the Bus Coupler and the complex terminals (KL15xx, KL25xx, KL3xxx, KL4xxx, KL5xxx, KL6xxx, KL8xxx) have been added to the Bus Coupler in the DP configuration tool in the sequence in which they are plugged in, the digital terminals follow. In the case of digital terminals, it is only necessary for the total of the digital inputs and outputs of the modules that have been added to agree with the number of digital inputs and outputs that are plugged in:

**Example:**

4 x KL1408 = 32 digital input bits

2 x KL2408 = 16 digital output bits

3 x KL1114 = 12 digital input bits

2 x KL2114 = 8 digital output bits

4 x KL1012 = 8 digital input bits

1 x KL2012 = 2 digital output bits

=> 52 digital input bits and 26 digital output bits

The following combinations of DP modules could, for instance, now be added in the DP configuration tool to the Bus Coupler:

**Alternative 1**

8 digital input bits

8 digital input bits

8 digital input bits

8 digital input bits

8 digital input bits

8 digital input bits

8 digital input bits

8 digital output bits

8 digital output bits

8 digital output bits

8 digital output bits

**Alternative 2**

56 digital input bits

32 digital output bits

Other alternatives are possible, provided the total of digital inputs is 56 bits (the next number larger than 52 divisible by 8) and that the sum of the digital outputs is 32 bits (the next number larger than 26 divisible by 8).

# GSD Files

The following GSD files are to be used in order to link the PROFIBUS coupler in the DP configuration tool:

## Standard GSD files

The standard GSD file contains all the important and fundamental properties required for operation of any master controller. The Bus Coupler can be parameterised in a clear and comprehensible manner with this GSD file.

Bus Coupler	German	English	as from firmware
BK3000	<a href="#">BK30becf.GSD</a>	<a href="#">BK30becf.GSE</a>	BN
BK3010	<a href="#">BK3010.GSD</a>	<a href="#">BK3010.GSE</a>	B9
BK3100	<a href="#">BK31bece.GSD</a>	<a href="#">BK31bece.GSE</a>	BT
BK3110	<a href="#">BK3110.GSD</a>	<a href="#">BK3110.GSE</a>	B9
BK3120	<a href="#">BK3120.GSG</a>	<a href="#">BK3120.GSE</a>	B9
BK3150	<a href="#">BK3150.GSG</a>	<a href="#">BK3150.GSE</a>	B0
BK3500	<a href="#">BK3500.GSD</a>	<a href="#">BK3500.GSE</a>	B9
BK3520	<a href="#">BK3520.GSD</a>	<a href="#">BK3520.GSE</a>	B9
LC3100	<a href="#">LC3100.GSD</a>	<a href="#">LC3100.GSE</a>	B9
BC3100	<a href="#">BC3100.GSD</a>	<a href="#">BC3100.GSE</a>	C3

## Extended GSD files

Additional settings are necessary for certain applications. These extended GSD files contain a large number of additional parameterisation options. It should be noted, however, that a thorough knowledge of the master controller along with excellent familiarity with the Beckhoff bus terminal system is necessary here.

Bus Coupler	German	English	as from firmware
BK3010	<a href="#">BK3010x.GSD</a>	<a href="#">BK3010x.GSE</a>	B9
BK3110	<a href="#">BK3110x.GSD</a>	<a href="#">BK3110x.GSE</a>	B9
BK3120	<a href="#">BK3120x.GSG</a>	<a href="#">BK3120x.GSE</a>	B9
BK3150	<a href="#">BK3150x.GSG</a>	<a href="#">BK3150x.GSE</a>	B0
BK3500	<a href="#">BK3500x.GSD</a>	<a href="#">BK3500x.GSE</a>	B9
BK3520	<a href="#">BK3520x.GSD</a>	<a href="#">BK3520x.GSE</a>	B9
LC3100	<a href="#">LC3100x.GSD</a>	<a href="#">LC3100x.GSE</a>	B9
BC3100	<a href="#">BC3100x.GSD</a>	<a href="#">BC3100x.GSE</a>	C3

Note on the extended GSD file:

**Note**

The GSD file contains a maximum of 244 bytes of input, output and configuration data. These are the maximum values. Below are the default of values and the [setting options](#).

DP buffer	Default	Maximum size
Inputs	128	244
Outputs	128	244
Diagnostic Data	64	64
Configuration data	64	244

The sizes can be adjusted through the [PrmData](#). The length is modified in steps of 8 bytes.

**Example:**

If it is desired to increase the size of the input data, other sizes must be reduced to compensate.

If we have 20 x 4 channel KL3314 thermocouples, then in compact mapping we find 20 Bus Terminals \* 4 channels \* 2 bytes per channel = 20 \* 4 \* 2 = 160 bytes

160 bytes is larger than the 128 byte default figure - settings must therefore be modified.

Set PrmData byte 12 bits 4-7 to 15 dec or 0xF hex, set byte for 37 to 160 (input data) and byte 38 to 96 (output data).

BECKHOFF Fieldbus Components: Configuration Software KS2000

## Configuration Software KS2000

The KS2000 configuration software permits configuration, commissioning and parameterization of bus couplers, of the affiliated bus terminals and of Fieldbus Box Modules. The connection between bus coupler/Fieldbus Box Module and the PC is established by means of the serial configuration cable or the fieldbus.





### Configuration

You can configure the Fieldbus stations with the Configuration Software KS2000 offline. That means, setting up a terminal station with all settings on the couplers and terminals resp. the Fieldbus Box Modules can be prepared before the commissioning phase. Later on, this configuration can be transferred to the terminal station in the commissioning phase by means of a download. For documentation purposes, you are provided with the breakdown of the terminal station, a parts list of modules used and a list of the parameters you have modified. After an upload, existing fieldbus stations are at your disposal for further editing.

### Parameterization

KS2000 offers simple access to the parameters of a fieldbus station: specific high-level dialogs are available for all bus couplers, all intelligent bus terminals and Fieldbus Box modules with the aid of which settings can be modified easily. Alternatively, you have full access to all internal registers of the bus couplers and intelligent terminals. Refer to the register description for the meanings of the registers.

### Commissioning

The KS2000 software facilitates commissioning of machine components or their fieldbus stations: Configured settings can be transferred to the fieldbus modules by means of a download. After a *login* to the terminal station, it is possible to define settings in couplers, terminals and Fieldbus Box modules directly *online*. The same high-level dialogs and register access are available for this purpose as in the configuration phase.

The KS2000 offers access to the process images of the bus couplers and Fieldbus Box modules.

- Thus, the coupler's input and output images can be observed by monitoring.
- Process values can be specified in the output image for commissioning of the output modules.

All possibilities in the *online mode* can be used in parallel with the actual fieldbus mode of the

terminal station. The fieldbus protocol always has the higher priority in this case.

BECKHOFF Fieldbus Components: Configuration

## Configuration via TwinCAT

The TwinCAT automation software is a complete automation solution for PC-compatible computers. TwinCAT turns any compatible PC into a real-time controller, an IEC 61131-3 Multi-PLC, NC positioning system, the corresponding programming environment and user interface. TwinCAT supports several different PROFIBUS DP PC cards. Beckhoff recommends the PROFIBUS DP PCI master card FC3101, which can also be obtained as a two-channel version (FC3102).

### System Manager

The TwinCAT System Manager Tool is used to configure the FC310x PROFIBUS DP PCI card. The System Manager provides a representation of the number of programs of the TwinCat PLC systems, the configuration of the axis control and of the connected I/O channels as a structure, and organises the mapping of the data traffic.



For applications without TwinCAT PLC or NC, the TwinCAT System Manager configures the programming interfaces for a wide range of application programs:

- ActiveX control (ADS-OCX) for e.g. Visual Basic, Visual C++, Delphi, etc.
- DLL interface (ADS-DLL) for e.g. Visual C++ projects
- Script interface (ADS script DLL) for e.g. VBScript, JScript, etc.

**The TwinCAT System Manager has the following properties:**

- Bit-wise association of server process images and I/O channels
- Standard data formats such as arrays and structures
- User defined data formats
- Continuous variable linking
- Drag and Drop
- Import and export at all levels

## Procedure when configuring the PROFIBUS DP input/output modules

1. The corresponding PROFIBUS DP master PC card is selected first, and inserted into the I/O configuration.

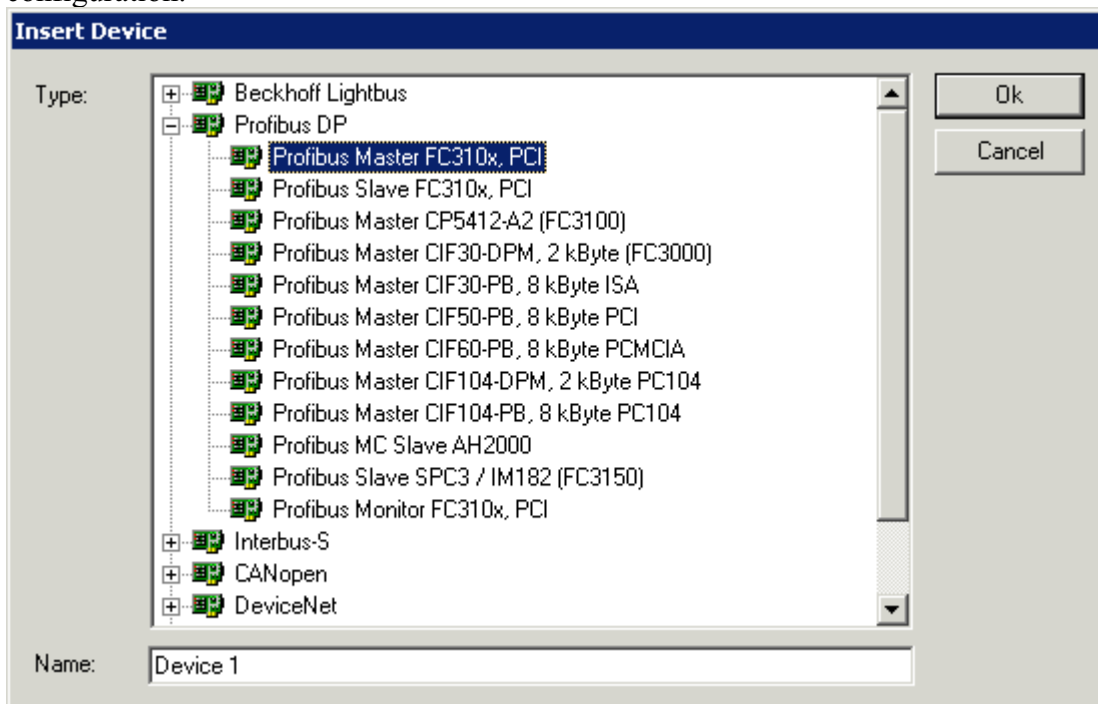

2. Following the master card, the bus nodes are then inserted:

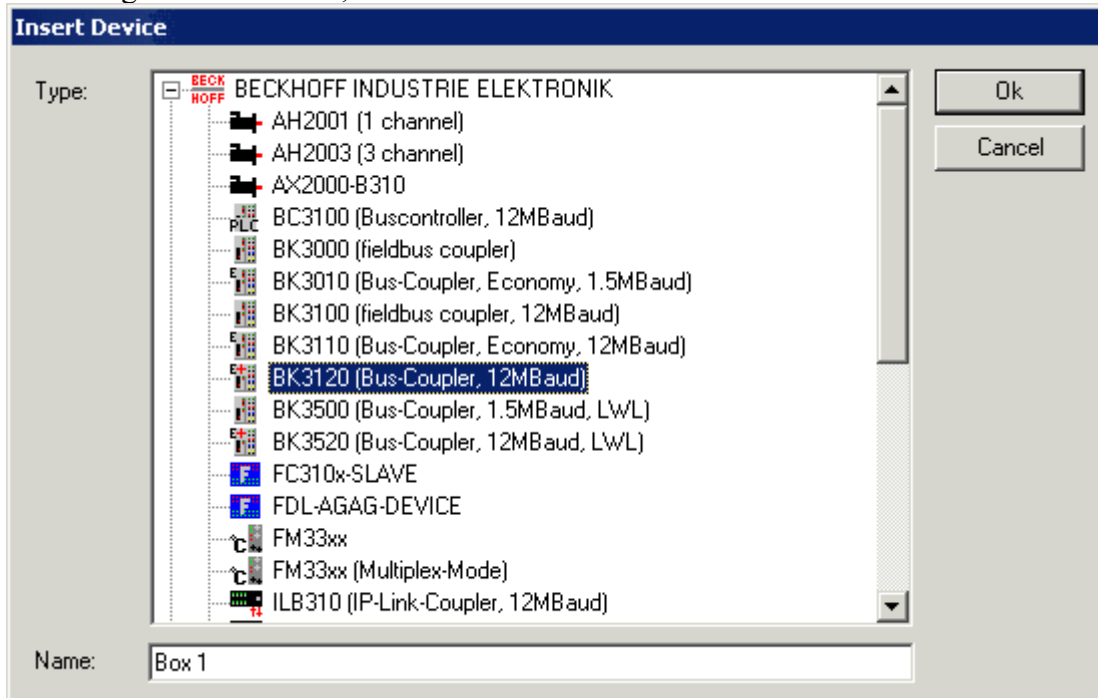

3. The appropriate Bus Terminals are now inserted at the PROFIBUS DP Bus Coupler.

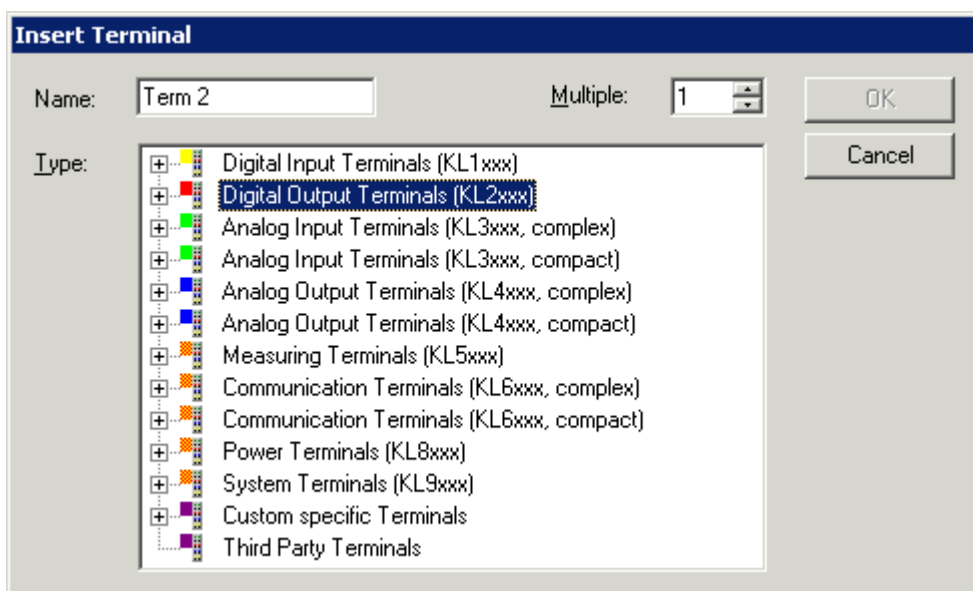

BECKHOFF Fieldbus Components: Configuration

## Configuration: Siemens S7 Controller

### Inserting the images

In order to assign an image to the devices in the Siemens software, they must be copied into the *Step7\S7Data\ncbmp* directory.

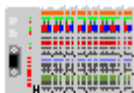

Busklemn.bmp

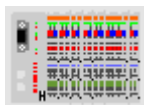

Busklems.bmp

### Inserting the GSD files

- Go to *Extras\Install new GSD* in the hardware catalog for your Step7.
- Select the directory in which the Beckhoff GSD is located, and import the files.
- You will then find them in the hardware catalog under *Profibus DP\Other field devices\I/O*.

BECKHOFF Fieldbus Components: Configuration

## Configuration: Siemens S7 Controller BK3120

## Parameter data for the BK3120

### Settings

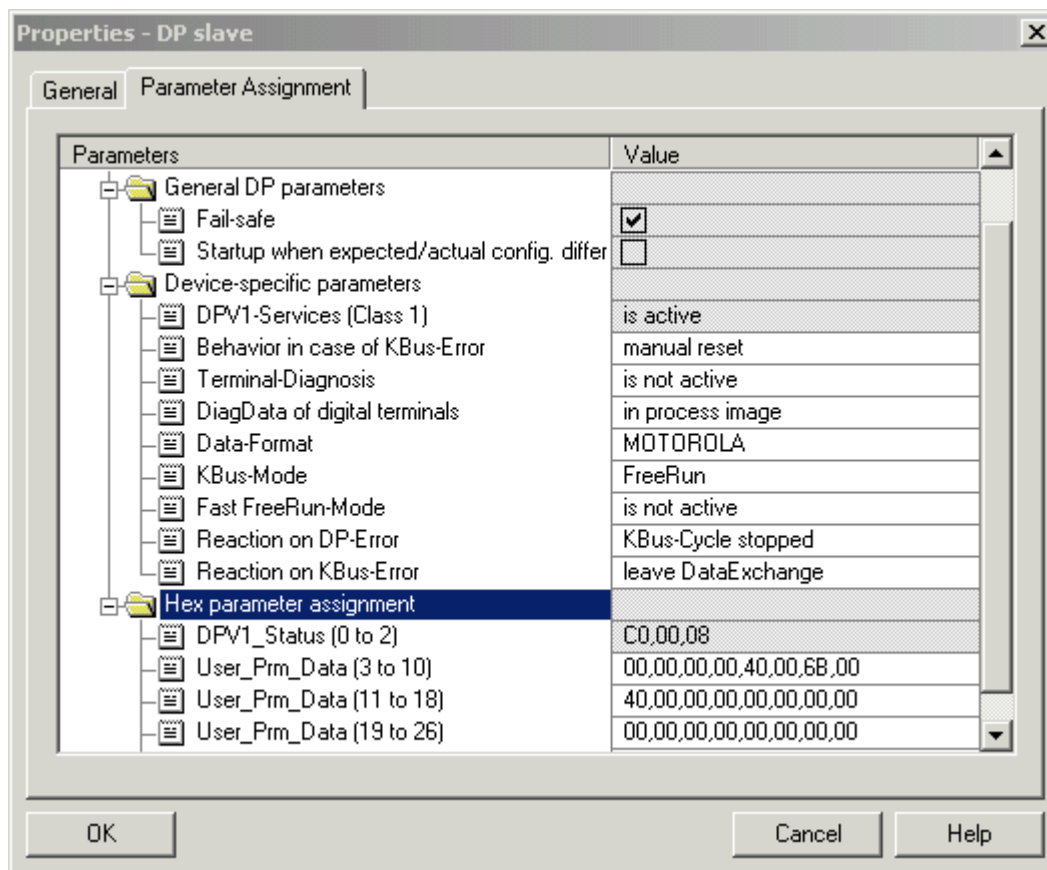

Parameter data	Denomination
DPV1 service (class 1)	<a href="#">DPV1 Services</a>
Reaction to Bus Terminal error	<a href="#">Reaction to Bus Terminal error</a>
Terminal bus diagnostics	<a href="#">PROFIBUS diagnosis</a>
Digital terminal diagnostic data	<a href="#">Digital Bus Terminal diagnostics</a>
Data format	<a href="#">Data format</a>
K-Bus mode	<a href="#">K-Bus update</a>
Fast FreeRun mode	<a href="#">Fast FreeRun mode</a>
Reaction to DP errors	<a href="#">Reaction to fieldbus error</a>
Reaction to K-Bus errors	<a href="#">Reaction to K-Bus errors</a>

## Configuration of the BK3120 module with digital inputs/outputs only

Example 1:

1 x BK3120

10 x KL1xx4

1 x KL9100 (is not entered, as this Bus Terminal is entirely passive)

11 x KL2xx4

1 x KL9010 (is not entered, as this Bus Terminal is entirely passive)

The sum total of digital bytes must be added together and entered.

Digital inputs

10 x KL1xx4, i.e. 10 x 4 bits = 40 bits

40 bits / 8 = 5 bytes, i.e. 5 x 8 bits entered or 1 x 40 bits or 1 x 8 bits + 1 x 32 bits etc. (see Fig. 2 and Fig. 3)

Digital outputs

11 x KL2xx4, i.e. 10 x 4 bits = 44 bits

44 bits / 8 = 5.5 bytes - rounded up to 6 bytes, i.e. 6 x 8 bits entered or 1 x 48 bits or 1 x 8 bits + 1 x 40 bits etc. (see Fig. 2 and Fig. 3)

The screenshot shows the SIMATIC 300(1) Configuration software interface. The main window displays a rack configuration with slots 1-7 and a PROFIBUS DP master system (1) connected to a BK312 module (12). Below the main window, a detailed configuration table for the BK312 module is shown, listing slots 0-12 with their respective modules and addresses.

Slot	Module / ...	Order number	I Address	Q Address	Comment
0	8DI	8 Bit digital inputs	0		
1	8DI	8 Bit digital inputs	1		
2	8DI	8 Bit digital inputs	2		
3	8DI	8 Bit digital inputs	3		
4	8DI	8 Bit digital inputs	4		
5	8DO	8 Bit digital outputs		0	
6	8DO	8 Bit digital outputs		1	
7	8DO	8 Bit digital outputs		2	
8	8DO	8 Bit digital outputs		3	
9	8DO	8 Bit digital outputs		4	
10	8DO	8 Bit digital outputs		5	
11					
12					

Fig. 2: Example of the entry of individual bytes. Note: Each individual byte requires one byte of ConfigData. In the BK3120 a maximum of 64 bytes of configuration data is available.

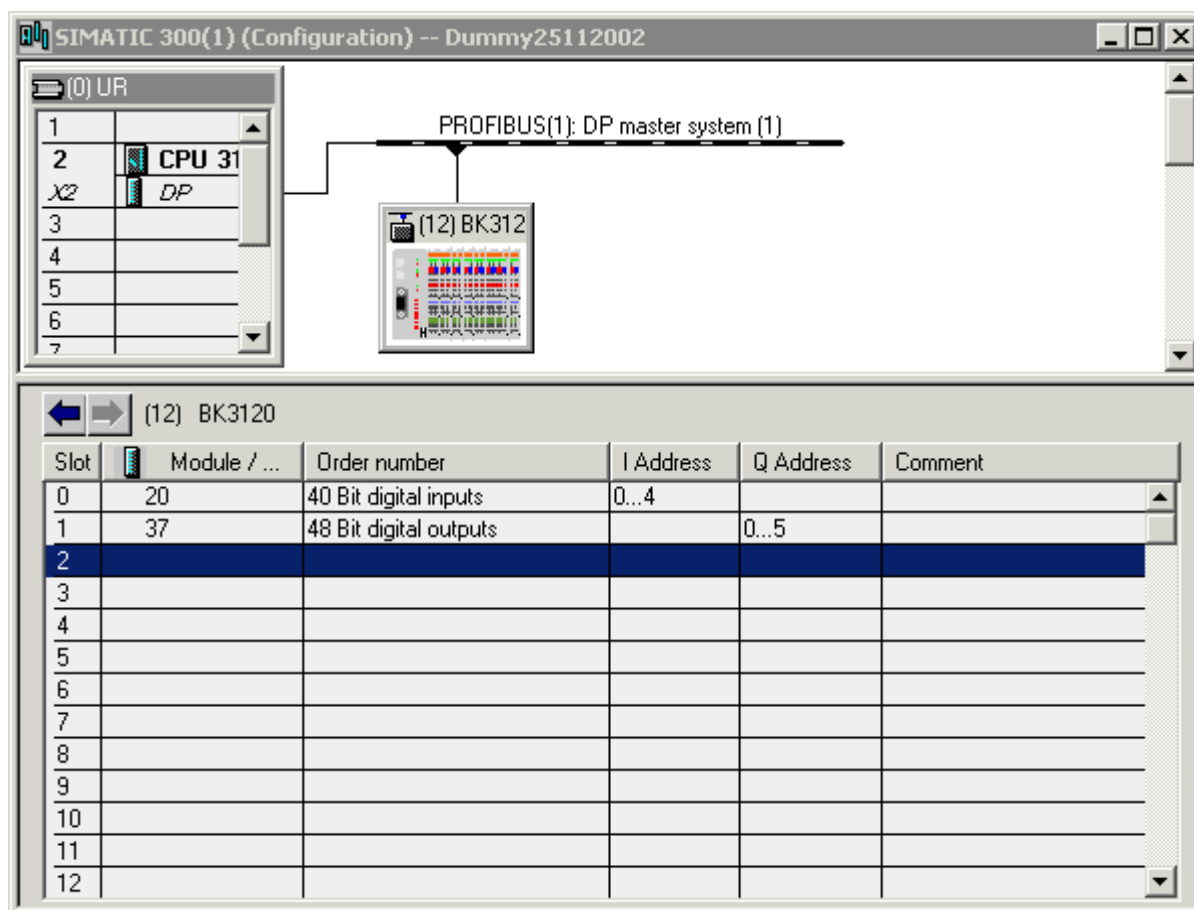

Fig. 3: Example of the entry of a group of associated bytes.

## Configuration of the BK3120 module with complex and digital input/outputs

Byte-oriented modules are the first to be mapped into the process image, and for this reason all the complex modules must first be entered in the sequence in which they are plugged into the Bus Coupler. For some byte-oriented Bus Terminals, it is possible to distinguish between compact and complex mapping.

Compact - only user data

Complex - user data plus status (for extended diagnosis) and control (for register communication)

Finally the digital signals are entered and rounded up to a whole byte.

Example 2.a:

1 x BK3120

2 x KL1012

1 x KL2022

1 x KL3312 compact mapping

1 x KL9010

PROFIBUS(1): DP master system (1)

(12) BK312

Slot	Module / DP Identifier	Order number	I Address	Q Address	Comment
0	2AI	KL3xx2 compact (16In)	256...259		
1	8DI	8 Bit digital inputs	0		
2	8DO	8 Bit digital outputs		0	
3					
4					
5					
6					
7					
8					
9					
10					
11					
12					

KL2502  
 KL2521  
 KL3351 c  
 KL3351 c  
 KL3361  
 KL3362  
 KL3403  
 KL3xx2 c  
 KL3xx2 c  
 KL3xx4 c  
 KL3xx4 c  
 KL4xx2 c  
 KL4xx2 c  
 KL4xx4 c  
 KL4xx4 c  
 KL4xx4 c  
 KL5001 c  
 KL5001 c  
 KL5051  
 KL5101  
 KL5111  
 KL5121  
 KL5151  
 KL5302  
 KL6001  
 KL6011  
 KL6021  
 KL6051 c  
 KL6051 c

Fig. 2a: Example of the KL3312 compact Bus Terminal

Example 2.b:

1 x BK3120

2 x KL1012

1 x KL2022

1 x KL3312 complex mapping

1 x KL9010



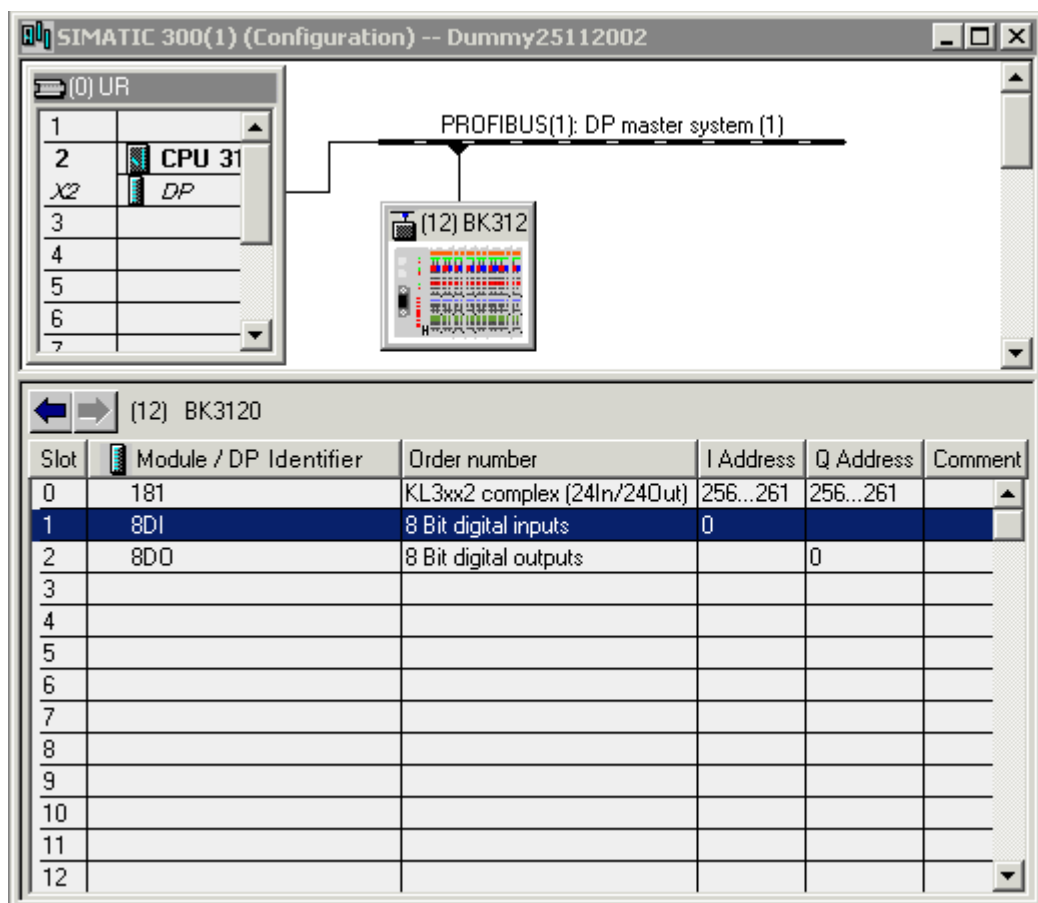

Slot	Module / DP Identifier	Order number	I Address	Q Address	Comment
0	181	KL3xx2 complex (24In/24Out)	256...261	256...261	
1	8DI	8 Bit digital inputs	0		
2	8DO	8 Bit digital outputs		0	
3					
4					
5					
6					
7					
8					
9					
10					
11					
12					

Example of the KL3312 complex Bus Terminal

BECKHOFF Fieldbus Components: Parameterisation and Commissioning

## Process Data, Process Image

The Bus Coupler includes different memory areas, each having a capacity of 256 words. Telegrams passing over the Lightbus can specifically access any desired memory cell. The control and status bytes in the Lightbus telegrams can be used to distinguish between two relevant regions of the memory and to address them separately. In order to initiate a Bus Coupler update, the value in the control and status bytes must be 0x10, while the data byte must contain the constant 80hex. It is possible to access the Bus Coupler data after this. For this purpose the control and status byte contains the value 0x30. Two bytes can be written and two bytes can be read simultaneously with one access. The process is described in detail in the following sections.

After being switched on, the Bus Coupler determines the configuration of the inserted input/output terminals. The assignment of the physical slots for the input/output channels and the addresses in the process image is carried out automatically by the Bus Coupler.

The Bus Coupler creates an internal assignment list, in which the input/output channels have a specific position in the process image of the Bus Coupler. A distinction is made here according to inputs and outputs, and according to bit-oriented (digital) and byte-oriented (analog or complex) signal processing.

Two groups are created, one for inputs and the other for outputs. Each group has the byte-oriented channels in ascending sequence, starting from the lowest address, and these are followed by the bit-oriented channels.

### Digital signals (bit-oriented)

The digital signals are bit-oriented. This means that one bit in the process image is assigned to each channel. The Bus Coupler creates a memory area containing the current input bits, and ensures that the bits in a second (output) memory area dedicated to the output channels are written out immediately, following the update command.

The details of the assignment of the input and output channels to the controller's process image is explained fully with the aid of an example in the appendix.

### Analog signals (byte-oriented)

The processing of analog signals is always byte-oriented. Analog input and output values are represented in memory by two bytes each. Values are represented in SIGNED INTEGER format. The number 0 stands for the input/output value 0 V, 0 mA or 4 mA. The maximum value of an output or input value is represented, according to the standard settings, by 0x7FFF. The intermediate values are correspondingly proportional. A range with a resolution of 15 bits is not achieved for all inputs and outputs. If the actual resolution is 12 bits, the last three bits have no effect in outputs, while as inputs they are read as 0. Each channel also has a control and status byte. The control and status byte is the most significant byte in the most significant word. An analog channel is represented by 4 bytes in the process image, of which 3 bytes are used. In the BK3000 and BK4000 only 2 bytes are occupied in the process image of the corresponding bus system for each analog channel. The Bus Terminal's control and status bytes can also be included through appropriate configuration of the Bus Coupler and Bus Terminals.

### Special signals and interfaces

The Bus Coupler supports Bus Terminals with other interfaces such as RS232, RS485, incremental encoder and others. These signals can be considered similarly to the analog signals named above. For some special signals the bit width of 16 is not sufficient. The Bus Coupler can support any byte width. It is necessary to consider how data consistency is ensured when accessing these values. This means that update commands must not be issued nor must the Bus Coupler be placed into the *free running* mode between the accesses.

### Default assignment of the inputs and outputs to the process image

Once it has been switched on, the Bus Coupler finds out how many Bus Terminals are inserted, and creates an assignment list. The analog and digital channels, divided into inputs and outputs, are assembled into separate parts of this list. The assignment starts on the left next to the Bus Coupler. The software in the Bus Coupler collects consecutively the individual entries for each of the channels in order to create the assignment list counting from left to right. Four groups are distinguished in the assignment:

Group	Functional type of the channel	Assignment
1	analog outputs	byte-wise
2	digital outputs	bit-wise
3	analog inputs	byte-wise
4	digital inputs	bit-wise

All complex Bus Terminals are represented by analog inputs or outputs.

### Overview of the distribution of the process image within the Bus Coupler

#### Output data in the Bus Coupler

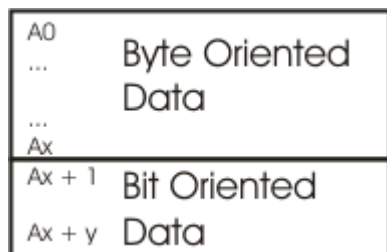

#### Input data in the Bus Coupler

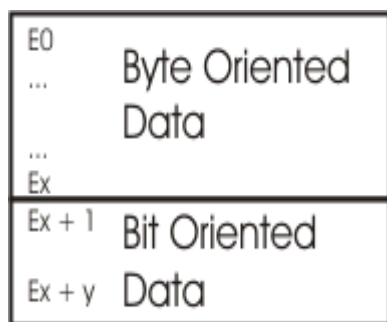

BECKHOFF Fieldbus Components: Parameterisation and Commissioning

## K-Bus Cycle

The K-Bus cycle can be set to run freely ([FreeRun mode](#)) or synchronously ([synchronous mode](#)) with respect to the DP cycle. The K-Bus cycle for the DP coupler consists of the following parts:

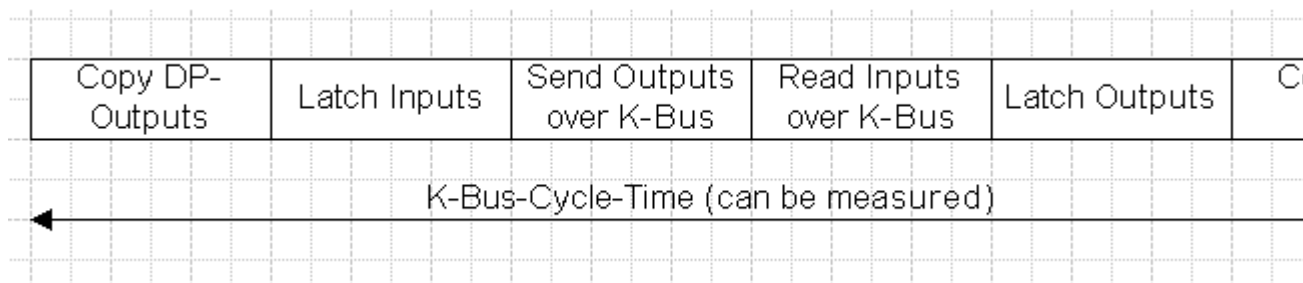

The K-Bus cycle time can be calculated to a precision of approximately 10% by means of the following formula (4-channel terminals or terminals with more than 6 bytes of data (exception: ASI terminal KL6201, which has more than 12 bytes of data) require two or more K-Bus cycles. The number of K-Bus cycles is in register ?? of table 90):

**Tcyc (in  $\mu\text{s}$ ) = number of K-Bus cycles x (600 + number of digital channels x 2.5 + number of analog input channels x 32 + number of analog output channels x 42)**

The K-Bus cycle time can be read via [DPV1](#). If TwinCAT is used, this is possible on the "Beckhoff" tab of the DP coupler in the System Manager.

## K-Bus modes

The K-Bus mode (the type of synchronisation between the K-Bus cycles and the DP cycle) is set via the [UserPrmData](#):

Byte 9, bit 4	Byte 9, bit 6	Byte 12, bit 0	Byte 12, bit 1	K-Bus mode
0 <sub>bin</sub>	1 <sub>bin</sub>	0 <sub>bin</sub>	0 <sub>bin</sub>	Slow FreeRun
1 <sub>bin</sub>	1 <sub>bin</sub>	0 <sub>bin</sub>	0 <sub>bin</sub>	Fast FreeRun
0 <sub>bin</sub>	0 <sub>bin</sub>	0 <sub>bin</sub>	0 <sub>bin</sub>	Synchronous
0 <sub>bin</sub>	0 <sub>bin</sub>	1 <sub>bin</sub>	0 <sub>bin</sub>	Synchronous with optimised input update, one cycle
0 <sub>bin</sub>	0 <sub>bin</sub>	0 <sub>bin</sub>	1 <sub>bin</sub>	Synchronous with optimised input update, two cycles

## FreeRun mode

### Slow FreeRun (default setting)

In the *FreeRun* mode there is no synchronisation between the K-Bus cycle and the DP cycle. It is a characteristic feature of the *Slow FreeRun* mode that the K-Bus cycle is called from the main task. Acyclic communication or events result in heavy jitter in the K-Bus cycle (KS2000, DPV1, terminal diagnosis, etc.), because all of these functions are also called from the main task.

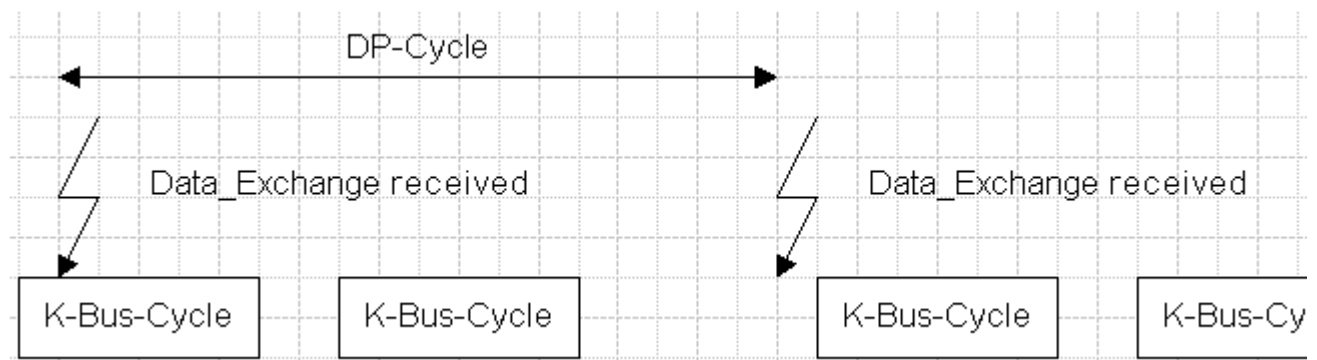

### Fast FreeRun

To avoid the jitter resulting from acyclic communication or events and to achieve fast K-Bus update times, the *Fast FreeRun* mode can be activated. The K-Bus cycle is called under time control from a high priority task. Following completion of the K-Bus cycle, the lower priority tasks (DPV1, KS2000 interface, etc.) are granted processor time for 12.5% of the duration of the foregoing K-Bus cycle, before the next K-Bus cycle is started. In fast FreeRun mode therefore the inputs and outputs are tightly up-to-date, but are not synchronised to the DP cycle:

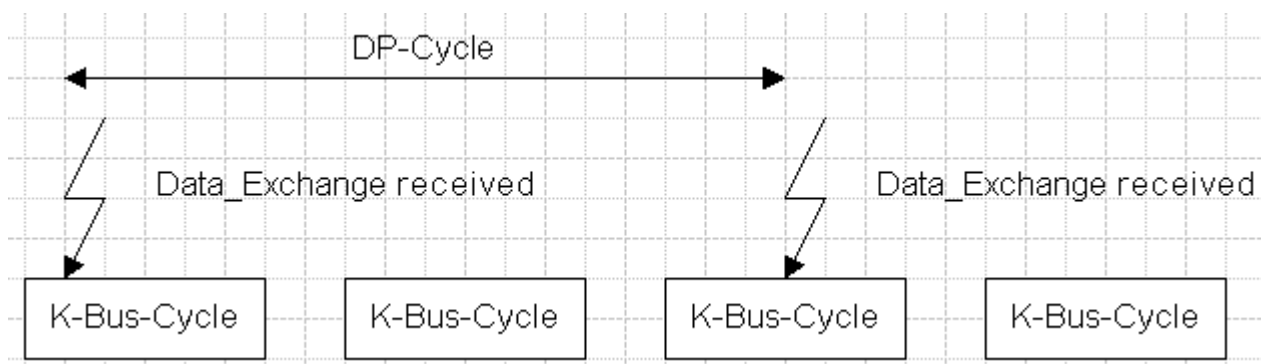

## Synchronous mode

As explained in the table above, there are three different synchronous modes:

### Standard synchronous mode

In standard synchronous mode the K-Bus cycle is always started immediately following reception of the Data\_Exchange telegram from the DP master. The outputs are therefore generated as quickly as possible, while the input cycles are always one DP cycle old:

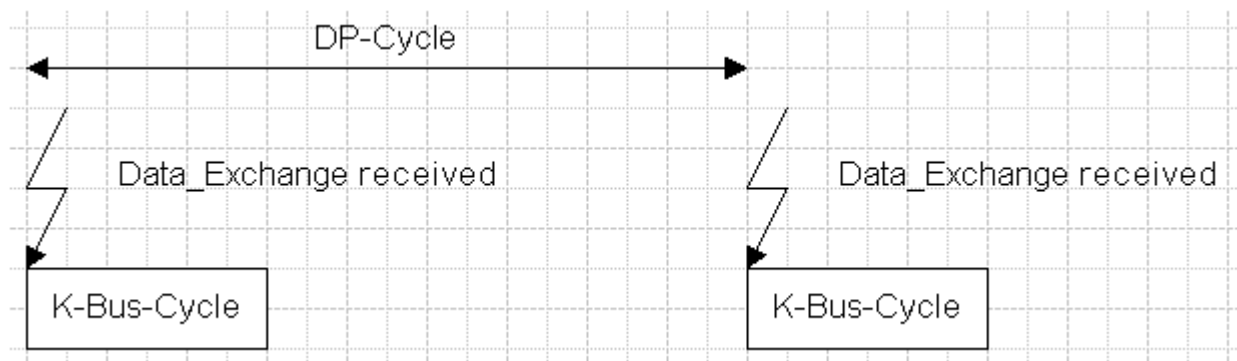

It is important here to ensure that the duration of the K-Bus cycle plus approx. 20% (to allow for the lower priority processes on the coupler) is shorter than the DP cycle time (which, under TwinCAT, means the cycle time of the associated task).

### Synchronous mode with optimised input update (one cycle)

In optimised input update, the start of the K-Bus cycle can be delayed following reception of the Data\_Exchange telegram, so that the inputs are more up-to-date than they are in standard synchronous mode, whereas generation of the outputs is more severely delayed. It is important here to ensure that the duration of the K-Bus cycle, plus the delay time, plus approx. 20% (to allow for the lower priority processes on the coupler) is shorter than the DP cycle time (which, under TwinCAT, means the cycle time of the associated task).

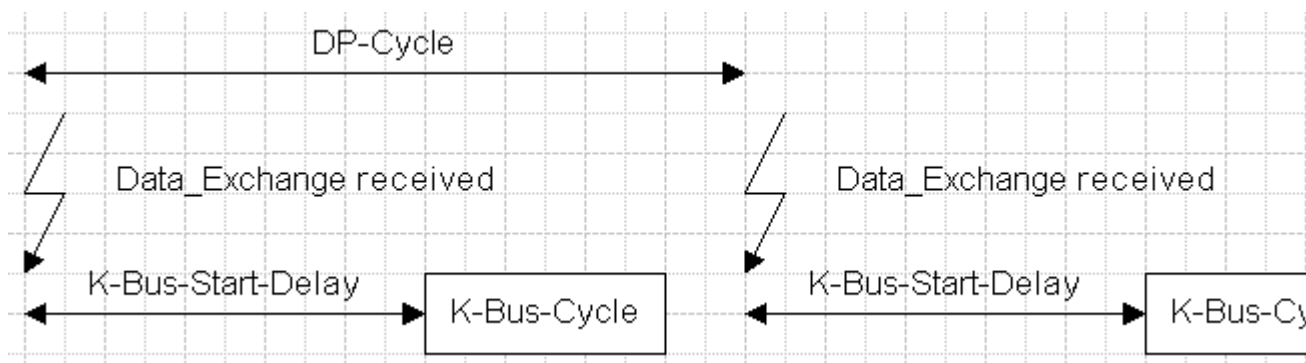

The delay time is set by means of the [UserPrmData](#) (in  $\mu\text{s}$ , in Motorola format). The extended GSD file of the Bus Coupler is, however, necessary for this:

Byte	Value: Description
13	Delay time (in $\mu\text{s}$ ) high byte
14	Delay time (in $\mu\text{s}$ ) low byte

### Synchronous mode with optimised input update (two cycles)

In the third mode of synchronous operation, the advantages of the other two operating modes are combined. Two K-Bus cycles are carried out within one DP cycle. The first cycle begins immediately after reception of the Data\_Exchange telegram from the master, which means that the outputs are generated as quickly as possible. The second cycle is started after a delay time that begins after completion of the first cycle has elapsed, so that the inputs are as recent as possible. It is important here to ensure that twice the duration of the K-Bus cycle, plus the delay time, plus approx. 20% (to allow for the lower priority processes on the coupler) is shorter than the DP cycle time (which, under TwinCAT, means the cycle time of the associated task).

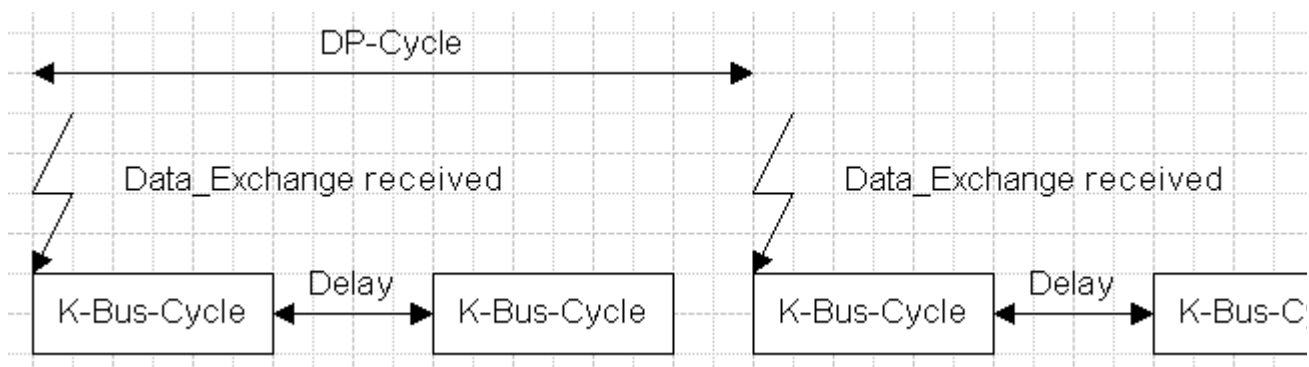

The delay time is set by means of the [UserPrmData](#) (in  $\mu\text{s}$ , in Motorola format). The extended GSD file of the Bus Coupler is, however, necessary for this:

Byte	Description
13	Delay time (in $\mu\text{s}$ ) high byte
14	Delay time (in $\mu\text{s}$ ) low byte

### Dummy output byte

The Bus Coupler's PROFIBUS DP ASIC can only generate an interrupt after reception of a Data\_Exchange telegram if output data has been received. This means that at least one output byte must be transferred via DP in synchronous mode. If only input terminals are plugged in, and no output data is therefore present, a dummy output byte can be configured. It is activated in the [UserPrmData](#), and must be entered as the module in the CfgData. The extended GSD file for the Bus Coupler is, however, necessary for this:

Byte	Bit	Value	Description
3	5	1 <sub>bin</sub>	Dummy output byte activated

It is also necessary for the dummy output byte to be configured in the CfgData before the complex terminals:

CfgData	DP modules
0x20	Dummy output byte

### K-Bus cycle counter

In order for the master to be able to check reliably whether precisely one (or two) K-Bus cycles are always being carried out during one DP cycle, a K-Bus cycle counter can be transferred in the input data from the Bus Coupler to the master. This is incremented after each K-Bus cycle (0 is omitted, so that 1 follows after 255). The K-Bus cycle counter must be activated in the UserPrmData and entered as a module in the CfgData. The extended GSD file for the Bus Coupler is, however, necessary for this:

Byte	Bit	Value	Description
3	3	1 <sub>bin</sub>	K-Bus cycle counter activated

It is also necessary for the K-Bus cycle counter byte to be configured in the CfgData before the complex terminals:

CfgData	DP modules
0x10	K-Bus cycle counter

BECKHOFF Fieldbus Components: Parameterisation and Commissioning

## DPV1 Interface

By default, one MSAC\_C1 connection and one MSAC\_C2 connection with 52 bytes of data (4 bytes DPV1 header plus 48 bytes of user data) are supported. The MSAC\_C1 connection is established along with cyclic connection, and can be activated via the [UserPrmData](#):

Byte	Bit	Value: Description
0	7	1: MSAC_C1 connection is activated

The MSAC\_C2 connection can be used either by the C1 master (which communicates with the slave cyclically) or by a C2 master (which then only communicates with the slave acyclically), and has its own establishment of connection. The parameters at the establishment of the MSAC\_C2 connection (Feature\_Supported, Profile\_Feature\_Supported, Profile\_Ident\_Number, etc.) are not examined, and the parameters of the request are mirrored in the response.

[Slot\\_Number](#) = 0 addresses PROFIBUS coupler data, [Slot\\_Number](#) > 0 addresses the data of the function module(s).

### PROFIBUS coupler data (Slot\_Number = 0)

The data associated with the PROFIBUS coupler is addressed via an index:

Index	Access	Description
1-2	R/W	<a href="#">Module assignment in multi-configuration mode</a>
5	R	<a href="#">Firmware information</a>
9-19	R/W	<a href="#">Device configuration</a> (Table 9)
90	R	<a href="#">K-Bus status</a> (Table 90)
98	R/W	<a href="#">Internal cycle time</a>
99	W	Commands: <a href="#">local bus reset</a> , <a href="#">starting or stopping the internal cycle time measurement</a>

### Function module data (Slot\_Number > 0)

Depending on the type of function module, access is made either to the registers (max. 4 channels, each with 64 registers) or to the parameters (only supported by a few function modules, where the quantity of data is insufficient for the register model)

### Accessing registers

Index	Access	Length	Description
0-63	R(/W)	2	Registers 0-63 of the channel 1 in the function module
64-127	R(/W)	2	Registers 0-63 of the channel 2 in the function module
128-191	R(/W)	2	Registers 0-63 of the channel 3 in the function module
192-254	R(/W)	2	Registers 0-63 of the channel 4 in the function module

### Accessing parameters

Index	Access	Length	Description
0	R(/W)	4-32 (must be divisible by 4)	Parameters 0x0000-0x0007 of the function module
1	R(/W)	4-32 (must be divisible by 4)	Parameters 0x0008-0x000F of the function module
...	...	...	
127	R(/W)	4-32 (must be divisible by 4)	Parameters 0x03F8-0x03FF of the function module

BECKHOFF Fieldbus Components: Parameterisation and Commissioning

## Assignment of the DPV1 Slot Number

The Slot\_Number = 0 addresses the data of the Bus Coupler, while Slot\_Number > 0 addresses the data (registers or parameters (KL6201)) of the complex terminals:

Device	Slot number = 0	Slot number > 0
BK3x20, BK3500	Data in Bus Coupler	Slot_Number = 1: first complex terminal plugged into the Bus Coupler (KL15xx, KL25xx, KL3xxx, KL4xxx, KL5xxx, KL6xxx, KL8xxx)  Slot_Number = 2: second complex terminal plugged into the Bus Coupler (KL15xx, KL25xx, KL3xxx, KL4xxx, KL5xxx, KL6xxx, KL8xxx)  etc.
BK3x10/LC3100	Data in Bus Coupler	Not present, because neither the BK3x10 nor the LC3100 support complex terminals.



BECKHOFF Fieldbus Components: Parameterisation and Commissioning

## Module Assignment

The [multi-configuration mode](#) is possible with a maximum of 128 modules (terminals, IE modules, etc.). The specification of which of the modules configured in the CfgData are indeed inserted can be written with DPV1 Write and read with DPV1 Read.

Slot number	Index	Length	Data	Description
0	1	1-15	Byte 0 (bit 0,1)	Assignment of module 1 <b>0: DP DataExchange (default)</b> 2: disabled (configured module missing)
			Byte 0 (bit 2,3)	Assignment of module 2 <b>0: DP DataExchange (default)</b> 2: disabled (configured module missing)
			Byte 0 (bit 4,5)	Assignment of module 3 <b>0: DP DataExchange (default)</b> 2: disabled (configured module missing)
			Byte 0 (bit 6,7)	Assignment of module 4 <b>0: DP DataExchange (default)</b> 2: disabled (configured module missing)
			Byte 1 (bit 0,1)	Assignment of module 5 <b>0: DP DataExchange (default)</b> 2: disabled (configured module missing)
			...	
			Byte 15 (bit 6,7)	Assignment of module 64 <b>0: DP DataExchange (default)</b> 2: disabled (configured module missing)
	2	1-15	Byte 0 (bit 0,1)	Assignment of module 65 <b>0: DP DataExchange (default)</b> 2: disabled (configured module missing)
			Byte 0 (bit 2,3)	Assignment of module 66 <b>0: DP DataExchange (default)</b> 2: disabled (configured module missing)
			Byte 0 (bit 4,5)	Assignment of module 67 <b>0: DP DataExchange (default)</b> 2: disabled (configured module missing)
			Byte 0 (bit 6,7)	Assignment of module 68 <b>0: DP DataExchange (default)</b> 2: disabled (configured module missing)
			Byte 1 (bit 0,1)	Assignment of module 69 <b>0: DP DataExchange (default)</b> 2: disabled (configured module missing)
			...	
			Byte 15 (bit 6,7)	Assignment of module 128 <b>0: DP DataExchange (default)</b> 2: disabled (configured module missing)

BECKHOFF Fieldbus Components: Parameterisation and Commissioning

## Firmware Information

The following firmware information can be read through DPV1. The data is transferred in Intel format (low byte first):

Slot number	Index	Byte	Description
0	5	0-1	Bus Coupler number
		2-3	Software version
		4-5	Manufacturer type (table 0, register 245)
		6-7	Coupler type (table 0, register 246)
		8-9	Bus Coupler type (table 0, register 247)
		10-11	reserved

BECKHOFF Fieldbus Components: Parameterisation and Commissioning

## Terminal Composition

The terminal composition can be read by DPV1. A word is transmitted for each terminal containing the terminal number for complex terminals (KL15xx, KL25xx, KL3xxx, KL4xxx, KL5xxx, KL6xxx, KL8xxx), and the length and type information for digital terminals:

Bit	Value	Description
0	1 <sub>bin</sub>	Digital terminal has inputs
1	1 <sub>bin</sub>	Digital terminal has outputs
2-7	-	reserved
8-14	X	Length in bits
15	1 <sub>bin</sub>	Always 1 <sub>bin</sub> (indicates that the terminal is digital)

## Reading the terminal composition

The terminal composition is represented in the DPV1 addressing as follows:

Slot number	Index	Byte	Description
0	9	0-1	Number of the Bus Coupler
		2-3	Value for terminal 1
		...	...
		46-47	Value for terminal 23
	10	0-1	Value for terminal 24
		...	...
		46-47	Value for terminal 47
	11	0-1	Value for terminal 48
	...	...	...
	18	46-47	Value for terminal 239
		0-1	Value for terminal 240

	19	...	...
		30-31	Value for terminal 255

## Checking the terminal composition

The same data can also be accessed by a DPV1 Write. In this case the Bus Coupler compares the value that has been written with the true value, returning a negative DPV1 Write response if the data does not agree. This permits more precise checking of the terminal configuration than is possible by checking the CfgData.

### Error codes in the write response

Error Code 1	Error Code 2
0xBE	Number of terminals
0xBF	First faulty byte in the written data

BECKHOFF Fieldbus Components: Parameterisation and Commissioning

## K-Bus Status

The K-Bus status can be read through DPV1. The data is transferred in Intel format (low byte first):

Slot number	Index	Byte	Description
0	90	0-1	Bit 0: Fieldbus errors
			Bit 1: K-Bus error
			Bit 2: Error on the Bus Terminal
			Bit 3: Coupler error
		2-3	In the presence of a coupler error: Error code
		4-5	K-Bus error = 0: Bit length of the K-Bus
			K-Bus error = 1: K-Bus error code (-> <a href="#">Diagnostic data</a> )
		6-7	K-Bus error = 0: Number of terminals
			K-Bus error = 1: Bus Terminal number following which the K-Bus error is detected (-> <a href="#">Diagnostic data</a> )

BECKHOFF Fieldbus Components: Parameterisation and Commissioning

## Cycle Time Measuring

The duration of the [process data cycle](#) can be measured with DPV1. /p>

The cycle time measurement is started or stopped using DPV1 Write:

Slot number	Index	Length	Data	Description

0	99	4	Byte 0: 0x04	Start the cycle time measurement
			Byte 1: 0x01	
			Byte 2: 0x01	
			Byte 3: 0x00	
0	99	4	Byte 0: 0x04	Stop the cycle time measurement
			Byte 1: 0x01	
			Byte 2: 0x00	
			Byte 3: 0x00	

The minimum, maximum, mean (of the last 200 cycles) and current cycle time can be read with DPV1 Read and reset with DPV1 Write:

Slot number	Index	Length	Data	Description
0	98	8	Byte 0, 1	Minimum cycle time in $\mu\text{s}$ (INTEL format, low byte first)
			Byte 2, 3	Maximum cycle time in $\mu\text{s}$ (INTEL format, low byte first)
			Byte 4, 5	Mean cycle time in $\mu\text{s}$ (INTEL format, low byte first)
			Byte 6, 7	Current cycle time in $\mu\text{s}$ (INTEL format, low byte first)

BECKHOFF Fieldbus Components: Diagnosis and Error Handling

## LEDs

### Overview

The Bus Coupler has two groups of LEDs for the display of status. The upper group (BK3xx0) or left hand group (LC3100) indicates the state of the fieldbus.

On the upper right hand side of the BK3xx0 Bus Coupler are two more green LEDs that indicate the supply voltage. The left hand LED indicates the presence of the 24 V supply for the Bus Coupler. The right hand LED indicates the presence of the supply to the power contacts. The two K-Bus LEDs (I/O RUN, I/O ERR) are located under the fieldbus LEDs. These indicate the operational state of the Bus Terminals and the connection to these Bus Terminals.

### Fieldbus LEDs

The upper three LEDs (or the two LEDs on the left) indicate the operating state of the PROFIBUS communication:

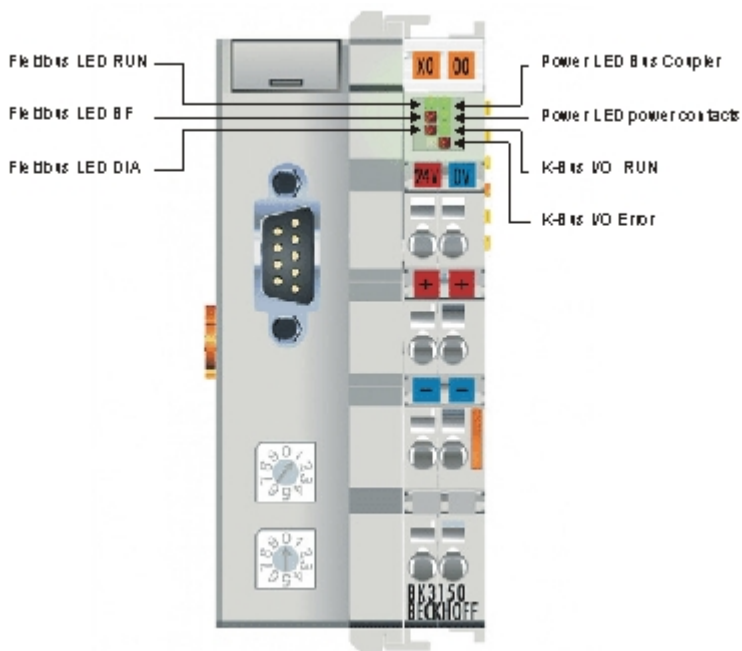
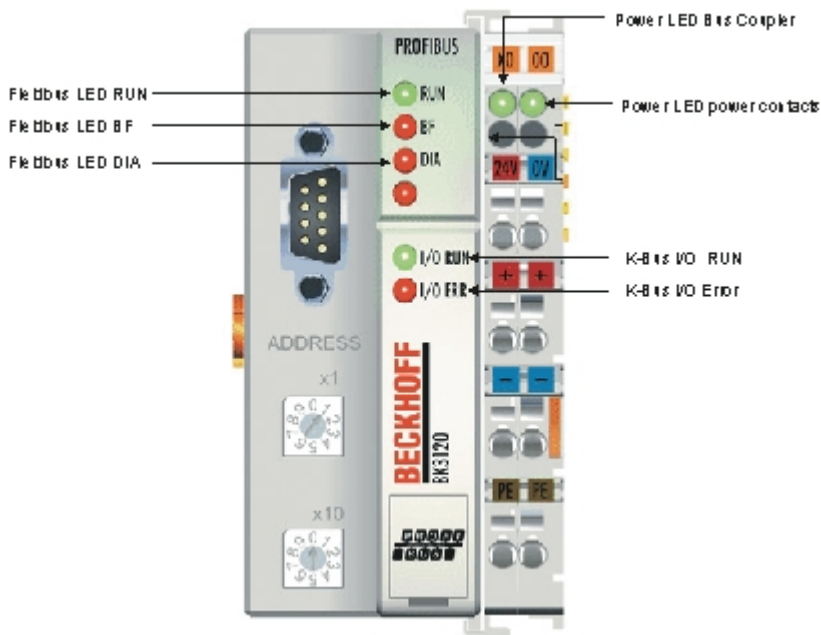

**BK3xx0**

I/O-RUN	BF	DIA	Meaning	Remedy
on	off	off	Operating state: RUN, Inputs are read and outputs are set	Everything is operating correctly
on	on	off, blinking	1. Bus activity, but slave is already parameterised	Start master
			2. Bus error with reaction to PROFIBUS error: a.) K-Bus outputs become 0 or b.) K-Bus outputs are retained	Check parameters, configuration ( <a href="#">possible error in DP start-up</a> )
off	off	off	Data exchange with the master is not started	Starts the PLC

off	on	on	No bus activity	Start the master, check the bus cable
off	on	off, blinking	Bus error with reaction to PROFIBUS error: K-Bus cycle is stopped	Start master, check parameters, configuration ( <a href="#">possible error in DP start-up</a> )

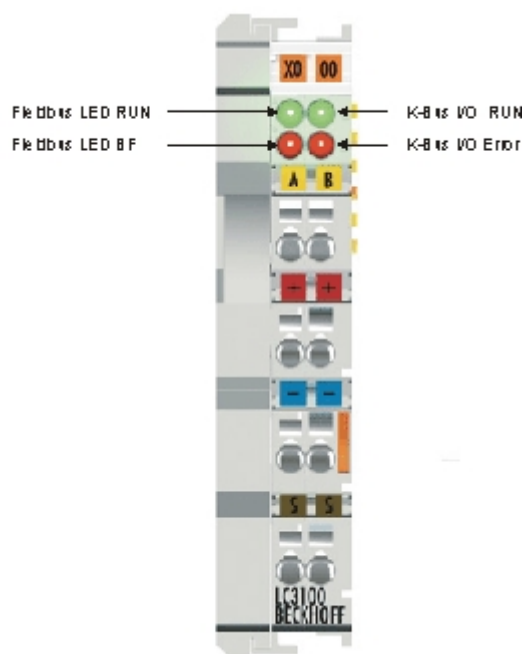

## LC3100

I/O-RUN	BF	RUN	Meaning	Remedy
on	off	on	Operating state: RUN, Inputs are read and outputs are set	Everything is operating correctly
on	on, blinking	on	1. Bus activity, but slave is already parameterised	Start master
			2. Bus error with reaction to PROFIBUS error: a.) K-Bus outputs become 0 or b.) K-Bus outputs are retained	Check parameters, configuration ( <a href="#">possible error in DP start-up</a> )
off	off	on	Data exchange with the master is not started	Starts the PLC
off	on	off	No bus activity	Start the master, check the bus cable
off	on, blinking	on	Bus error with reaction to PROFIBUS error: K-Bus cycle is stopped	Start master, check parameters, configuration ( <a href="#">possible error in DP start-up</a> )

## DIA-LED blink codes

If an error occurs in the parameterisation or configuration during [DP start-up](#), this is indicated both through the fieldbus LEDs and in the diagnostic data.

## Blink Code

<b>Fast blinking</b>	<b>Start of the error code</b>
<b>First slow sequence</b>	Error code
<b>Second slow sequence</b>	Error argument (error location)

## K-Bus LEDs (local errors)

Two LEDs, the K-Bus LEDs, indicate the operational state of the Bus Terminals and the connection to these Bus Terminals. The green LED (I/O RUN) lights up in order to indicate fault-free operation. The red LED (I/O ERR) flashes with two different frequencies in order to indicate an error. The errors are displayed in the blink code in the following way:

### Error type

Error code	Error code argument	Description	Remedy
<b>Persistent, continuous blinking</b>	-	General K-bus error.	Check the Bus Terminal strip
<b>1 pulse</b>	0	EEPROM checksum error.	Set manufacturer's setting with the KS2000 software
	1	Inline code buffer overflow.	Connect fewer Bus Terminals; too many entries in the table for the programmed configuration
	2	Unknown data type.	Software update required for the coupler
<b>2 pulses</b>	0	Programmed configuration incorrect.	Check programmed configuration for correctness
	n>0	Incorrect table entry Bus Coupler / incorrect table comparison (Bus Terminal n).	Correct table entry / Bus Coupler
<b>3 pulses</b>	0	K-Bus command error.	No Bus Terminal connected; attach Bus Terminals
			One of the Bus Terminals is defective; halve the number of Bus Terminals attached and check whether the error is still present with the remaining Bus Terminals. Repeat until the defective Bus Terminal is located.
<b>4 pulses</b>	0 n	K-Bus data error, break behind Bus Coupler n.	Check whether the n+1 Bus Terminal is correctly connected; replace if necessary. Check whether the End Terminal 9010 is connected.
<b>5 pulses</b>	n	K-Bus error in register communication with Bus Terminal n.	Replace Bus Terminal n.
<b>7 pulses</b>	n	BK3x10 or LC3100: unsupported Bus Terminal detected at location n.	Only use digital (bit oriented) Bus Terminals, or use a BK3120 Bus Coupler.
		Checksum error in program	Set manufacturer's setting with the

<b>9 pulses</b>	0	flash memory.	KS2000.
<b>13 pulses</b>	0	Runtime K-Bus command error.	One of the Bus Terminals is defective; halve the number of Bus Terminals attached and check whether the error is still present with the remaining Bus Terminals. Repeat until the defective Bus Terminal is located.
<b>14 pulses</b>	n	Bus Terminal n has the wrong format	Start the coupler again, and if the error occurs again then exchange the Bus Terminal.
<b>15 pulses</b>	n	Number of Bus Terminals is no longer correct	Start the coupler again, and if the error occurs again after this, use the KS2000 software to set manufacturer's settings.
<b>16 pulses</b>	n	Length of the K-Bus data (bit length) is no longer correct. n = bit length after booting	
<b>17 pulses</b>	n	Number of Bus Terminals is no longer correct. n = number of Bus Terminals after booting.	
<b>18 pulses</b>	n	Bus Terminal identifier no longer correct after reset (n = Bus Terminal number).	

### Error location

The number of pulses indicates the position of the last Bus Terminal before the fault. Passive Bus Terminals, such as a power feed terminal, are not included in the count.

BECKHOFF Fieldbus Components: Diagnosis and Error Handling

## DP Diagnostic Data (DiagData)

The DP diagnostic data consists of six bytes of DP standard diagnosis, along with up to 238 bytes of device-specific diagnostic data. The device-specific diagnostic data for Beckhoff slaves is represented in the DPV1 status message.

When the DP diagnostic data changes, the slave reports this fact to the master, and the master will automatically fetch the changed diagnostic data. This means that DP diagnostic data is not included in the DP process data in real-time, but is always sent to the controller a few cycles later.

In TwinCAT the DP diagnostic data is read from the DP Master interface (FC310x, CX1500-M310) using ADS (see the section describing Slave Diagnostics in the FC310x documentation).

### DP standard diagnostic data

Offset	Meaning
0x00.0	StationNonExistent: slave did not reply to the last telegram
0x00.1	StationNotReady: slave still processing the Set_Prm / Chk_Cfg telegram
0x00.2	CfgFault: slave signalling a configuration error
0x00.3	ExtDiag: extended DiagData available and valid
0x00.4	NotSupported: slave does not support a feature requested via Set_Prm or



	Global Control
0x00.5	InvalidSlaveResponse: slave response not DP-compatible
0x00.6	PrmFault: slave reports a parameterisation error
0x00.7	MasterLock: slave currently exchanging data with another master
0x01.0	PrmReq: re-parameterise and reconfigure slave
0x01.1	StatDiag: slave signalling static diagnosis / DPV1 slave application not yet ready for data exchange
0x01.2	PROFIBUS DP slave
0x01.3	WdOn: DP watchdog on
0x01.4	FreezeMode: DP slave in freeze mode
0x01.5	SyncMode: DP slave in sync mode
0x01.6	reserved
0x01.7	Deactivated: DP slave has been deactivated
0x02.0	reserved
0x02.1	reserved
0x02.2	reserved
0x02.3	reserved
0x02.4	reserved
0x02.5	reserved
0x02.6	reserved
0x02.7	ExtDiagOverflow: too much extended data present
0x03	MasterAdd: station address of master with which slave is exchanging data
0x04, 0x05	IdentNumber
from 0x06	Device-specific diagnostic data (extended DiagData)

## Device-specific diagnostic data (DPV1 status message)

The meaning of the first 4 bytes of the DPV1 status message is specified by the DPV1 standard, while the bytes that follow are manufacturer-specific.

Byte	Bit	Description
6	0-7	The length of the DPV1 status message (including this byte)
7	0-7	StatusType: the StatusType identifies the format of the diagnostic data starting at byte 16 ( <b>0x81</b> : max. 64 modules, <b>0xA1</b> : more than 64 modules)
8	0-7	SlotNumber: always 0
9	0-7	Specifier: always 0
10	0	EEPROM checksum error (can be cleared by setting the manufacturers setting through KS2000 or <a href="#">DPV1</a> , followed by a power off/power on cycle)
10	4	Unknown module type
10	5	The length of the CfgData is too great (too many modules are inserted)
10	6	The length of the DP input data is too great (too many modules are inserted)
10	7	The length of the DP output data is too great (too many modules are inserted)
11	0-7	<a href="#">Error on an internal bus</a> (K-Bus, IP-Link, etc.)
12	0-7	Error code on an internal bus (K-Bus, IP-Link, etc.)
13	0-7	Error argument on an internal bus (K-Bus, IP-Link, etc.)

14	0-7	<a href="#">DP start-up error code</a>
15	0-7	<a href="#">DP start-up error argument</a>

### Errors in the modules (terminals, IP modules, IE module, etc.)

[Diagnosis of the modules](#) must be activated through the [UserPrmData](#).

### Couplers with a maximum of 64 possible modules

Byte	Bit	Description
16	0-5	Module number (0-63) with an error (bit 6 of the status bytes is set, except for the serial interface modules (KL6001, KL6011, KL6021, IP6002, IP6012, IP6022, IE6002, IE6012, IE6022), where bit 3 of the status byte is set)
16	6-7	Associated channel number (0-3)`
17	0-7	Status byte of the faulty channel (bits 0-7)
18	0-5	Module number (0-63) with an error (bit 6 of the status bytes is set, except for the serial interface modules (KL6001, KL6011, KL6021, IP6002, IP6012, IP6022, IE6002, IE6012, IE6022), where bit 3 of the status byte is set)
18	6-7	Associated channel number (0-3)`
19	0-7	Status byte of the faulty channel (bits 0-7)
...	...	...
60	0-5	Module number (0-63) with an error (bit 6 of the status bytes is set, except for the serial interface modules (KL6001, KL6011, KL6021, IP6002, IP6012, IP6022, IE6002, IE6012, IE6022), where bit 3 of the status byte is set)
60	6-7	Associated channel number (0-3)`
61	0-7	Status byte of the faulty channel (bits 0-7)

### Couplers with a maximum of more than 64 possible modules

Byte	Bit	Description
16	0-7	Module number (1-255) with an error (bit 6 of the status bytes is set, except for the serial interface modules (KL6001, KL6011, KL6021, IP6002, IP6012, IP6022, IE6002, IE6012, IE6022), where bit 3 of the status byte is set)
17	6-7	Associated channel number (0-3)`
17	0-5	Status byte of the faulty channel (bits 0-5)
18	0-7	Module number (1-255) with an error (bit 6 of the status bytes is set, except for the serial interface modules (KL6001, KL6011, KL6021, IP6002, IP6012, IP6022, IE6002, IE6012, IE6022), where bit 3 of the status byte is set)
19	6-7	Associated channel number (0-3)`
19	0-5	Status byte of the faulty channel (bits 0-5)
...	...	...
60	0-7	Module number (1-255) with an error (bit 6 of the status bytes is set, except for the serial interface modules (KL6001, KL6011, KL6021, IP6002, IP6012, IP6022, IE6002, IE6012, IE6022), where bit 3 of the status byte is set)
61	6-7	Associated channel number (0-3)`

61	0-5	Status byte of the faulty channel (bits 0-5)
----	-----	--

BECKHOFF Fieldbus Components: Diagnosis and Error Handling

## Errors during DP Start-up

If an error occurs in the [parameterisation \(UserPrmData\)](#) or [configuration \(CfgData\)](#) during DP start-up, this is indicated both through the [fieldbus LEDs](#) and in the [diagnostic data \(DiagData\)](#).

Possible DP start-up errors are identified by an error code and an error argument.

### Errors when checking the UserPrmData

#### Error code 1

Error code 1 indicates that a reserved bit in the UserPrmData has been set to an incorrect value, or that the function corresponding to the bit in the UserPrmData is not supported. The error argument describes which UserPrmData byte has been detected as containing an error (the offset of the faulty byte + 1).

#### Error code 3

Error code 3 indicates that a combination of functions selected in the UserPrmData is not allowed. The error argument describes the impermissible combination.

Error code argument	Description
1	The <a href="#">Reaction to DP error</a> cannot be set to "Outputs unchanged" in <a href="#">synchronous mode</a>
2	The <a href="#">DPV1-MSAC_C1 connection</a> has been activated by the master, but no DPV1-MSAC_C1 connection is defined
6	The <a href="#">Multi-configuration mode</a> is not allowed if <a href="#">Checking the CfgData is switched off</a>
8	<a href="#">Synchronous mode</a> may only be activated when at least one DP output byte is configured
10	The <a href="#">optimised input cycle</a> is only possible in <a href="#">synchronous mode</a>
11	The length of the DP buffer exceeds the size of the DP RAM in the PROFIBUS ASIC
12	<a href="#">Fast-FreeRun mode</a> may not be activated together with <a href="#">synchronous mode</a>

### Errors when checking the CfgData

#### Error code 2

Error code 2 indicates that a byte in the CfgData is not correct. The error argument describes which CfgData byte has been detected as containing an error (the offset of the faulty byte + 1).

#### Error code 5

Error code 5 indicates that the length of the digital outputs (in bytes) calculated from the CfgData is not correct. The error argument contains the expected byte length.

## Error code 6

Error code 6 indicates that the length of the digital inputs (in bytes) calculated from the CfgData is not correct. The error argument contains the expected byte length.

## Error code 7

Error code 7 indicates a variety of errors when checking the CfgData. The error argument describes the error.

Error argument	Description
1	The length of the CfgData received is not correct
2	The syntax of the CfgData received is not correct
3	The length of the DP input data that has been calculated from the CfgData is too large
4	The length of the DP output data that has been calculated from the CfgData is too large

## Errors during slave start-up

### Error code 8

Error code 8 indicates that the length of the DP buffer is greater than the size of the DP RAM in the PROFIBUS ASIC. The error argument contains the difference (divided by 8). DP communication is deactivated.

### Error code 9

Error code 9 indicates a variety of errors that may be detected as the device boots. The error argument describes the error.

Error argument	Description
1	The length of the DP input data is too great (too many modules are inserted)
2	The length of the DP output data is too great (too many modules are inserted)
3	The length of the CfgData is too great (too many modules are inserted)

BECKHOFF Fieldbus Components: Diagnosis and Error Handling

## Reaction to PROFIBUS Error

A PROFIBUS error (failure of the master, withdrawal of the PROFIBUS plug etc.) is detected after the DP watchdog has elapsed (usually in the region of 100 ms, unless this has been deactivated in the master) or by bus timeout (the baud rate supervision time is set to 10 s).

The reaction at the output data of the coupler can be set in the [UserPrmData](#):

Byte	Bit	Value	Description
10	0-1	00 <sub>bin</sub>	Reaction to PROFIBUS error: K-Bus cycle is abandoned (default, digital outputs become 0, complex outputs are set to a planned substitute value)
		01 <sub>bin</sub>	Reaction to PROFIBUS error: K-Bus outputs become 0
		10 <sub>bin</sub>	Reaction to PROFIBUS error: K-Bus outputs remain unchanged

## BECKHOFF Fieldbus Components: Diagnosis and Error Handling

## K-Bus Interruption

If the K-Bus is interrupted, or suffers from a relatively long malfunction, the coupler enters the *K-Bus error* state. Depending on the setting made for *Reaction to K-Bus error* in the [UserPrmData](#), the coupler abandons DP data exchange and sets the Stat\_Diag bit in the [diagnostic data](#) at the next DP start-up (with the consequence that DP data exchange is not carried out), sets the DP inputs to 0, or leaves the DP inputs unchanged.

Byte	Bit	Value	Description
10	2-3	00 <sub>bin</sub>	Reaction to K-Bus error: DP data exchange is abandoned (default)
		01 <sub>bin</sub>	Reaction to K-Bus error: DP inputs set to 0
		10 <sub>bin</sub>	Reaction to K-Bus error: DP inputs remain unchanged

When the interruption or malfunction on the K-Bus has been rectified, the setting of *Response to K-Bus error* in the [UserPrmData](#) determines whether the *K-Bus error* state is left manually (by means of a K-Bus reset), or automatically:

Byte	Bit	Value	Description
7	0	0 <sub>bin</sub>	Response to K-Bus error: manual K-Bus reset (default)
		1 <sub>bin</sub>	Response to K-Bus error: automatic K-Bus reset

## Signalling the K-Bus error

A K-Bus error is indicated both on the *I/O-ERR* LED and in the DPV1 status message in the [DP diagnostic data](#) (bytes 11-13).

Byte	Bit	Description
11	0	too many K-Bus command errors
11	1	too many K-Bus timeouts
11	2	too many K-Bus receive errors
11	3	too many K-Bus transmit errors
11	4	K-Bus reset error
11	5	general K-bus error
12	0-7	K-Bus error code
13	0-7	K-Bus error argument

## K-Bus reset

A K-Bus reset can be carried out manually by means of a DPV1 Write:

Slot number	Index	Byte	Value
0	99	0	2
		1	1
		2	0
		3	0

## BECKHOFF Fieldbus Components: Diagnosis and Error Handling

## Terminal Diagnostics

If terminal diagnosis has been activated, then each channel of a complex terminals is examined to see whether bit 6 in the status has changed (exceptions are the KL6001, KL6011 and KL6021, where the relevant bit is bit 3), and whether the diagnostic bit of each channel of a digital terminal with diagnostics (KL12x2 or KL22x2) has changed. If that is the case, the existence of new diagnostic data is reported to the master, and two bytes of diagnostic information starting at byte 16 of each channel for which a diagnosis is pending are inserted (see [Diagnostic data](#)).

Terminal diagnosis can be activated in the [UserPrmData](#):

Byte	Bit	Value	Description
7	1	1 <sub>bin</sub>	Terminal diagnosis is active

## Digital terminal diagnosis

By default, the diagnostic bits for the digital terminals that have diagnosis (KL12x2 and KL22x2) are transmitted cyclically in the process image. These terminals occupy 4 bits each in both the input and output data. If terminal diagnosis is active, then UserPrmData can be used to specify that only the I/O data for the digital terminals with diagnosis (KL12x2: 2 bit inputs, KL22x2: 4 bit outputs) is to be included in the cyclic process image transfer:

Byte	Bit	Value	Description
7	4	1 <sub>bin</sub>	Diagnostic data of digital terminals not in the cyclic process image

## Real-time capacity of the diagnostic data

When making use of terminal diagnosis, it should always be borne in mind that the diagnostic data always reaches the controller at least one cycle later, and that as a rule access also takes place through different mechanisms from those used for cyclic process data. This means that process data can already be faulty, but the controller program is only informed of this in the following cycle or the one after that. If the diagnostic bits of digital terminals with diagnosis, or the status of complex terminals, is mapped into the process image, then the controller program always has consistency between the process data and the diagnostic data. The appropriate setting therefore depends on the way that the diagnosis is to be used. If it is only intended for diagnostic display, transmission within the cyclic process data is unnecessary, but if on the other hand consistency between the process data and the diagnostic data is desired, then the diagnostic data should be transmitted along with the cyclic process data.

## Maximum diagnosis data length

If more terminal diagnosis data is present than is specified in the maximum diagnostic data length, then the ExtDiagOverflow bit is set in the standard [diagnostic data](#). Because older controllers have difficulties with the maximum diagnostic data length of 64 bytes (which is the default setting), the maximum diagnostic data length can be restricted in the [UserPrmData](#):

Byte	Bit	Description
11	3-6	Maximum length of the diagnostic data. Allowed values: 16, 24, 32, 40, 48, 56, 64

It is only possible to set the maximum diagnostic data length in text form in the extended GSD file.

BECKHOFF Fieldbus Components: Extended Functions

## 2-byte PLC Interface

Checking the CfgData can be deactivated if a DP master is not capable of operating with the modules listed in the GSD file. In that case the master can send any CfgData, and as many inputs and outputs are transferred as are described by the CfgData.

Deactivation of the CfgData checking can also be useful if a specific address range is to be reserved in the PLC for future extensions. In that case, more input and output data is to be transferred than is in fact necessary.

Deactivation of the CfgData check can be set in the [UserPrmData](#):

Byte	Bit	Value	Description
1	0	1 <sub>bin</sub>	CfgData checking is deactivated

In general, the I/O data from the modules (terminals or IE modules) is written by the coupler in the standard sequence (first the complex, then the digital modules), as is also the case for other fieldbus couplers; this has already been described in connection with the structure of the process image in the coupler. The decision on a module-to-module basis as to whether the module is mapped in compact or complex form, which would otherwise be possible under DP, is omitted when CfgData checking is deactivated. In that case, the setting made in the UserPrmData applies to all modules:

The compact or complex mapping can be set in the [UserPrmData](#):

Byte	Bit	Value	Description
9	2	0 <sub>bin</sub>	Analog modules are mapped in compact form (only with the input or output user data)
		1 <sub>bin</sub>	Analog modules are mapped in complex form (including control/status for register access and the same data length in the inputs and outputs)

The extended GSD file must be used to deactivate CfgData checking and to specify compact/complex mapping textually in the master's configuration tool.

BECKHOFF Fieldbus Components: Extended Functions

## Word Alignment

In order to obtain the I/O data in the controller's process image in a clear form in controllers with word-oriented process images, it is possible to specify that word alignment is used when the coupler generates its process image. This involves a dummy byte being inserted for every variable that is larger than one byte and which would start on an uneven address.

Word alignment can be set in the [UserPrmData](#):

Byte	Bit	Value	Description
9	5	1 <sub>bin</sub>	Word alignment is active

When using the DP modules it is necessary to ensure that only those complex modules that are identified with word alignment are used.

The extended GSD file must be used in order to set word alignment in text form in the master's configuration tool and to be able to select the word alignment module.

BECKHOFF Fieldbus Components: Extended Functions

## Deactivating the CfgData Check

Checking the CfgData can be deactivated if a DP master is not capable of operating with the modules listed in the GSD file. In that case the master can send any CfgData, and as many inputs and outputs are transferred as are described by the CfgData.

Deactivation of the CfgData checking can also be useful if a specific address range is to be reserved in the PLC for future extensions. In that case, more input and output data is to be transferred than is in fact necessary.

Deactivation of the CfgData check can be set in the [UserPrmData](#):

Byte	Bit	Value	Description
1	0	1 <sub>bin</sub>	CfgData checking is deactivated

In general, the I/O data from the modules (terminals or IE modules) is written by the coupler in the standard sequence (first the complex, then the digital modules), as is also the case for other fieldbus couplers; this has already been described in connection with the structure of the process image in the coupler. The decision on a module-to-module basis as to whether the module is mapped in compact or complex form, which would otherwise be possible under DP, is omitted when CfgData checking is deactivated. In that case, the setting made in the UserPrmData applies to all modules:

The compact or complex mapping can be set in the [UserPrmData](#):

Byte	Bit	Value	Description
9	2	0 <sub>bin</sub>	Analog modules are mapped in compact form (only with the input or output user data)
		1 <sub>bin</sub>	Analog modules are mapped in complex form (including control/status for register access and the same data length in the inputs and outputs)

The extended GSD file must be used to deactivate CfgData checking and to specify compact/complex mapping textually in the master's configuration tool.

BECKHOFF Fieldbus Components: Extended Functions

## Multi-Configuration Mode

### Applications of the multi-configuration mode

Multi-configuration mode can be used for the following types of application. A more extensive consideration, considering, in particular, the various implementation levels of the Bus Coupler, is given in the [Requirements of a production machine](#).

### Creating a DP configuration for various implementation levels of the Bus Coupler

If it is desired to use one PLC program to control different implementation levels of a process, it can be valuable to work with the same DP configuration in spite of differences between the implementation-specific terminal configurations. In this way the address offsets in the process image do not change, nor will the general DP configuration of the Profibus DP



master have to be saved again with every new implementation level. With the multi-configuration mode it is now possible to define a maximum configuration for the Bus Coupler, and in this case it will only be necessary to disable those terminals that are not present in accordance with the current implementation level.

## Reserved Bus Terminals

Because all the analog terminals are configured first in the DP configuration, before the digital terminals, the consequence of inserting analog terminals at a later stage is that the address offsets of the digital terminals are shifted. The insertion of a digital terminal within the existing terminal structure (which can, for instance, be useful if digital terminals with different input voltages are used) also has the consequence that the offsets of the digital terminals that follow it are shifted. If a digital terminal is inserted before the end terminal however, the offset of the existing terminals are not shifted. With multi-configuration mode it is now possible to configure additional terminals as reserves at any location within the terminal structure.

## Assigning the Bus Terminals to freely chosen process image addresses

Because digital terminals are always grouped into bytes, which therefore means that the smallest DP configuration module is an 8-bit module, a difficulty arises when the associated terminals are to be distributed over a number of bytes in the PLC process image. This is because in the PLC it is usually only possible to assign addresses for each DP configuration module. With multi-configuration mode it is now possible to configure additional digital terminals as "dummy" terminals at any desired locations, enabling the address offsets of the other terminals to be shifted in the PLC process image.

## Setting the multi-configuration mode

Multi-configuration mode is activated via the [UserPrmData](#):

Byte	Bit	Description
3	4	1: Multi-configuration mode is active

## Rules for multi-configuration mode

Multi-configuration mode requires a few additional rules to be observed, in addition to those for standard configuration:

- Only one DP module may be configured for each analog terminal
- The digital terminals are to be declared as KLxxxx Multi-Cfg mode modules at their true position
- The digital terminals are to be declared after the analog modules moreover as input/output sum modules, corresponding to their bit width, as is also the case for standard configuration in the process image.
- All modules for the maximum configuration, including the reserve modules, are to be declared
- Modules that are not inserted must be disabled

## Enabling/disabling Bus Terminals

Those Bus Terminals that are present in the DP configuration, but that are not in fact plugged in, must be disabled. This can be done in the [UserPrmData](#), via DPV1, KS2000 or through the 2-byte PLC interface.

Making the setting through DPV1 or through the 2-byte PLC interface has the advantage that the terminal assignment for the multi-configuration mode can usually be made directly from the PLC program, without having to change the DP configuration of the master.

As long as the inserted Bus Terminals do not agree with the non-disabled Bus Terminals to be expected from the DP configuration, the Bus Terminal will normally set the *Stat\_Diag* bit in the diagnostic data, with the consequence that it is not yet ready for cyclic data exchange.

If, however, the enabling and disabling is to be carried out via the 2-byte PLC interface, it is a precondition for function of the 2-byte PLC interface that the coupler is in cyclic data exchange mode. For that reason it is also possible to deactivate remaining in the *Stat\_Diag* state:

Byte	Bit	Description
3	6	1: In multi-configuration mode the coupler also enters the data exchange even when the configuration is not consistent, although K-Bus cycles are not yet executed

### Enabling/disabling via UserPrmData

The assignment of the terminals (a maximum of 128 terminals is possible) is entered from byte 15 to byte 30 and from byte 41 to byte 56 of the [UserPrmData](#). Two bits are reserved here for each terminal, indicating whether the relevant terminal is enabled (value 0) or disabled (value 2). If the UserPrmData is to be displayed as text in the DP configuration tool, then the parameters *Assignment of module x* are to be set to *DP DataExchange (enabled)* or *Multi-Config. mode (disabled)*.

Byte	Bit	Description
15	0,1	Assignment for terminal 1 <b>0: DP DataExchange (default)</b> 2: disabled (Multi-Config mode)
	2,3	Assignment for terminal 2 <b>0: DP DataExchange (default)</b> 2: disabled (Multi-Config mode)
	4,5	Assignment for terminal 3 <b>0: DP DataExchange (default)</b> 2: disabled (Multi-Config mode)
	6,7	Assignment for terminal 4 <b>0: DP DataExchange (default)</b> 2: disabled (Multi-Config mode)
...	...	...
30	6,7	Assignment for terminal 64 <b>0: DP DataExchange (default)</b> 2: disabled (Multi-Config mode)
41	0,1	Assignment for terminal 65 <b>0: DP DataExchange (default)</b> 2: disabled (Multi-Config mode)
...	...	...
56	6,7	Assignment for terminal 128 <b>0: DP DataExchange (default)</b> 2: disabled (Multi-Config mode)

### Enabling/disabling via DPV1 Write

The terminals are enabled/disabled through Slot\_Number 0 and Index 1 or 2:

Index	Byte	Bit	Description
1	0	0,1	Assignment for terminal 1 <b>0: DP DataExchange (default)</b> 2: disabled (Multi-Config mode)
		2,3	Assignment for terminal 2 <b>0: DP DataExchange (default)</b> 2: disabled (Multi-Config mode)
		4,5	Assignment for terminal 3 <b>0: DP DataExchange (default)</b> 2: disabled (Multi-Config mode)
			Assignment for terminal 4

		6,7	<b>0: DP DataExchange (default)</b> 2: disabled (Multi-Config mode)
	...	...	...
	15	6,7	Assignment for terminal 64 <b>0: DP DataExchange (default)</b> 2: disabled (Multi-Config mode)
2	0	0,1	Assignment for terminal 65 <b>0: DP DataExchange (default)</b> 2: disabled (Multi-Config mode)
	...	...	...
	15	6,7	Assignment for terminal 128 <b>0: DP DataExchange (default)</b> 2: disabled (Multi-Config mode)

### Enabling/disabling via the 2-byte PLC interface or through KS2000

The terminals are enabled or disabled through table 1, registers 0-31:

Register	Bit	Description
	0,1	Assignment for terminal 1 <b>0: DP DataExchange (default)</b> 2: disabled (Multi-Config mode)
	2,3	Assignment for terminal 2 <b>0: DP DataExchange (default)</b> 2: disabled (Multi-Config mode)
	4,5	Assignment for terminal 3 <b>0: DP DataExchange (default)</b> 2: disabled (Multi-Config mode)
	6,7	Assignment for terminal 4 <b>0: DP DataExchange (default)</b> 2: disabled

		(Multi-Config mode)
	8,9	Assignment for terminal 5 <b>0: DP DataExchange (default)</b> 2: disabled (Multi-Config mode)
	10,11	Assignment for terminal 6 <b>0: DP DataExchange (default)</b> 2: disabled (Multi-Config mode)
	12,13	Assignment for terminal 7 <b>0: DP DataExchange (default)</b> 2: disabled (Multi-Config mode)
	14,15	Assignment for terminal 8 <b>0: DP DataExchange (default)</b> 2: disabled (Multi-Config mode)
0	...	...
31	14,15	Assignment for terminal 128 <b>0: DP DataExchange (default)</b> 2: disabled (Multi-Config mode)



Note

It can happen under multi-configuration mode that the CfgData exceeds 64 bytes. In such a case, the [CfgData](#) must be enlarged.

BECKHOFF Fieldbus Components: Extended Functions

## Changing the Size of the Process Data

## Exceeding the input data length (InputData)

By default, a maximum of 128 bytes of input data is set on the Bus Coupler.

The maximum length of the DP buffer can be changed. The amount, however, by which one length is increased must be taken away from another, and it must be noted that the sizes can only be changed in 8-byte steps:

## Exceeding the output data length (OutputData)

By default, a maximum of 128 bytes of output data is set on the Bus Coupler.

The maximum length of the DP buffer can be changed. The amount, however, by which one length is increased must be taken away from another, and it must be noted that the sizes can only be changed in 8-byte steps:

## Exceeding the configuration data length (CfgData)

By default, a maximum of 64 bytes of configuration data is set on the Bus Coupler. Normally, this is only a problem in very rare cases. In multi-configuration mode, however, this limit is reached with no more than a 30 digital terminals, because each KLxxxx MultiCfgMode module occupies two bytes in the configuration data, on top of which there is at least one sum byte for digital inputs or for digital outputs.

The maximum length of the DP buffer can be changed. The amount, however, by which one length is increased must be taken away from another, and it must be noted that the sizes can only be changed in 8-byte steps:

### Maximum DP buffer sizes

DP buffer	Maximum sizes under default settings
Inputs	128 bytes
Outputs	128 bytes
Diagnostic data	64 bytes
Configuration data	64 bytes

### Setting via the 2-BYTE PLC interface or KS2000

The maximum DP buffer sizes can be modified in Table 100, although it is necessary for the Bus Coupler to be reset (power off/power on, or a software reset) before the new value is adopted:

Register	Description
2	maximum length of input data
3	maximum length of output data
4	maximum length of diagnosis data
5	maximum length of configuration data

### Setting via UserPrmData

The Bus Coupler's reset is carried out automatically if the DP buffers are set using [UserPrmData](#):

Byte	Bit	Description
12	4-7	15 dec or 0xF hex: the maximum DP buffer lengths are changed using the values from UserPrmData 37-40
37	0-7	maximum length of input data

38	0-7	maximum length of output data
39	0-7	maximum length of diagnosis data
40	0-7	maximum length of configuration data

Example 1: Not enough configuration data

128 bytes input  
 128 bytes output  
 80 bytes CfgData  
 48 bytes diagnosis data

Example 2: Not enough input data

160 bytes input  
 96 bytes output  
 64 bytes CfgData  
 64 bytes diagnosis data

BECKHOFF Fieldbus Components: Extended Functions

# Implementation Levels of the Bus Coupler in Multi-Configuration Mode

## Structure of a production machine

Production machines often consist of a machine part that is always present in the machine and of machine extensions that may be added as options. This division also usually applies as well both to the software (the control program) and to the hardware (the necessary process signals via Beckhoff Bus Terminals) associated with the machine. A machine, with machine extensions A, B and C, whose process signals are to be read or output over the PROFIBUS DP through Beckhoff Bus Couplers BK3110, BK3120 or BK3520, could be structured as follows:

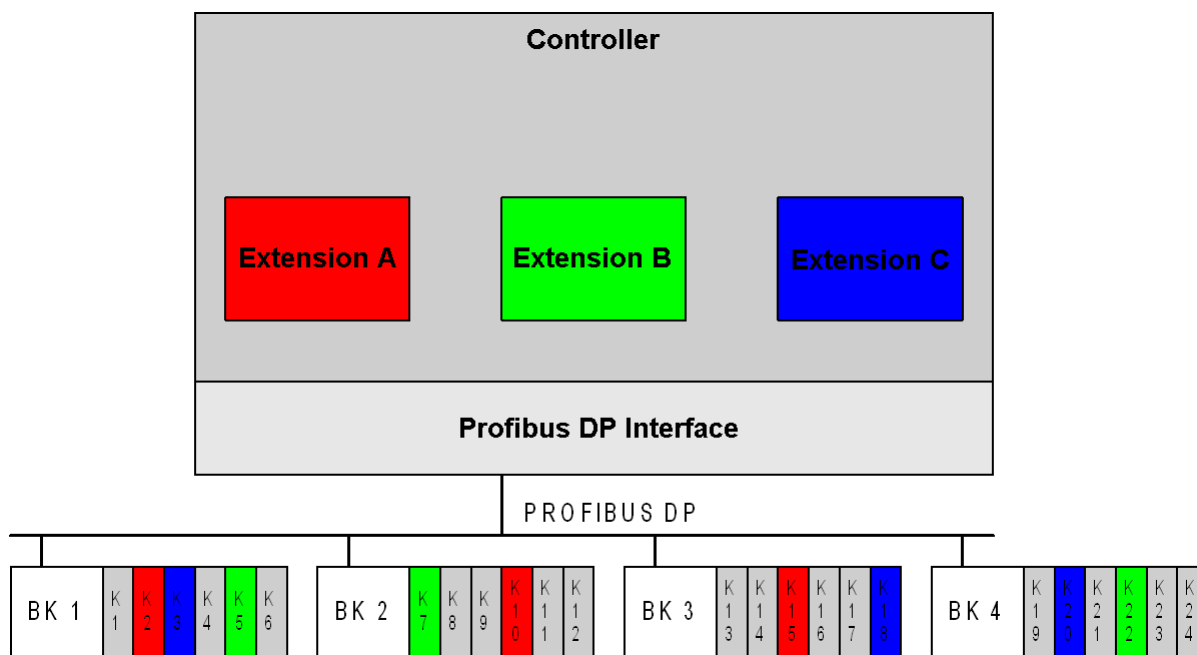

The machine illustrated consists of a controller (e.g. TwinCAT, S7-400, etc.), a PROFIBUS DP master interface (e.g. FC3101, CP???, etc.) that sends or receives the process signals over the PROFIBUS DP, and of Bus Couplers with Bus Terminals that form the interface to the machine process. The areas shown in grey relate to machine parts that are always present. The machine extensions A, B and C are shown in red, green and blue. It can be seen that each machine extension is associated both with software modules within the control program and process signals that are connected to the

controller via Bus Terminals.

Because the machine builder will not want to maintain eight different control programs for all possible combinations of the machine extensions, it is helpful if the control program is designed in such a way that the necessary software modules are activated according to whichever machine extensions are in fact being used. In order to create a control program suited to all implementation levels of the machine it is however necessary for the same process signals always to appear at the same addresses in the controller's process image, independently of which process signals are in fact present in the relevant implementation level. For conventional DP slaves, a different configuration of the PROFIBUS DP master interface is necessary in such cases. The following sections explain how this problem can be solved with Beckhoff Bus Couplers, using a single configuration of the PROFIBUS DP master interface.

The advantage of this solution is that two machine configurations only differ in terms of the hardware used (machine components and Bus Terminals), but not in terms of the software. If the machine is upgraded, it is only necessary for the additional Bus Terminals to be inserted and wired-up, and for the relevant extension to be activated (e.g. via the man-machine interface to the machine). Software changes are no longer required.

### Process image interfaces

The interfaces between controller, PROFIBUS DP master interface, Bus Coupler and Bus Terminals form process images, in which the process signals are stored according to certain algorithms:

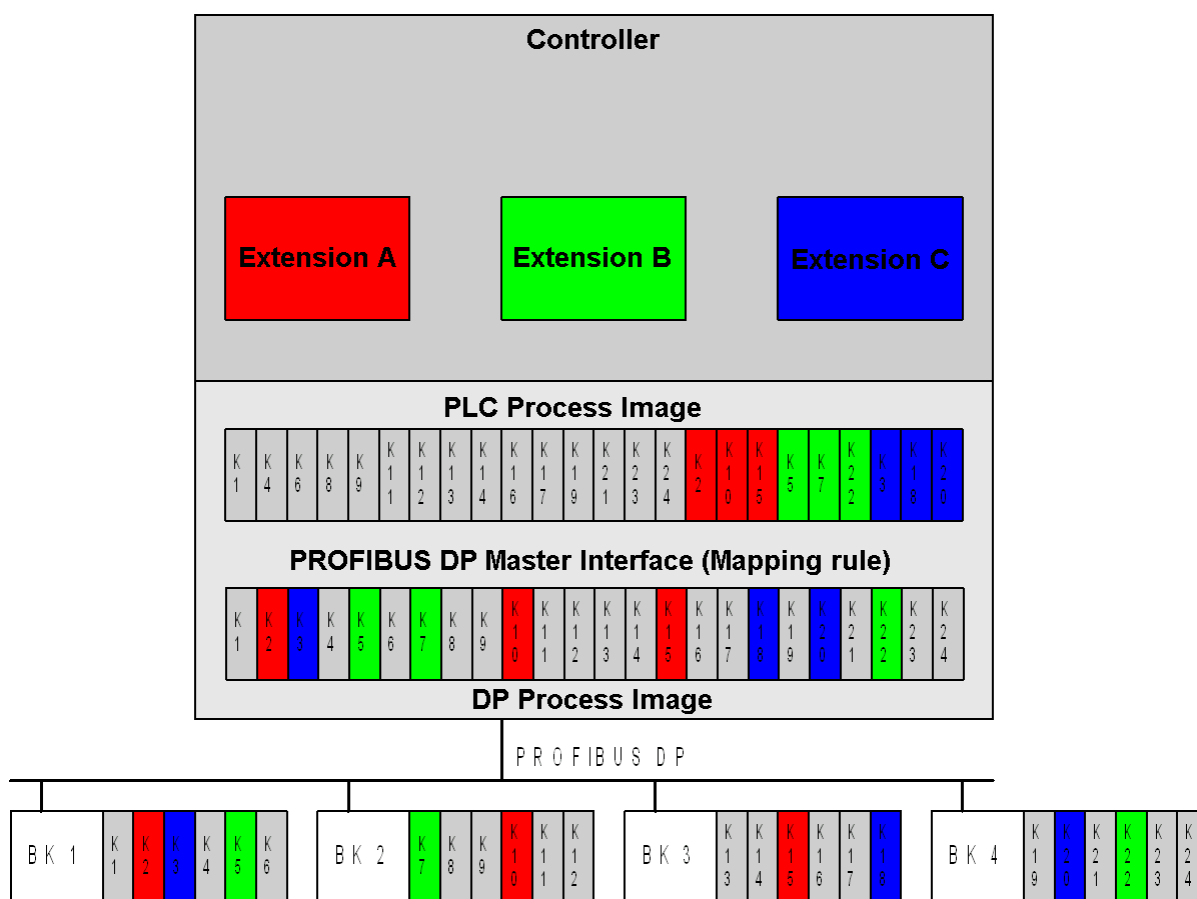

The process signals of a DP slave (Bus Coupler BK3110, BK3120 or BK3520) are always transferred in a Data\_Exchange telegram, in which the outputs are sent by the DP master and the inputs are received in the associated telegram response. In the PROFIBUS DP master interface, the process images exchanged with the Bus Couplers are mapped to the process images of the control according to a mapping rule.

### Process images of the machine configurations

As shown in the two examples in the figure below, the mapping rule in the PROFIBUS DP master interface changes, depending on which machine extensions are used (there are two examples here):

Only Extension A

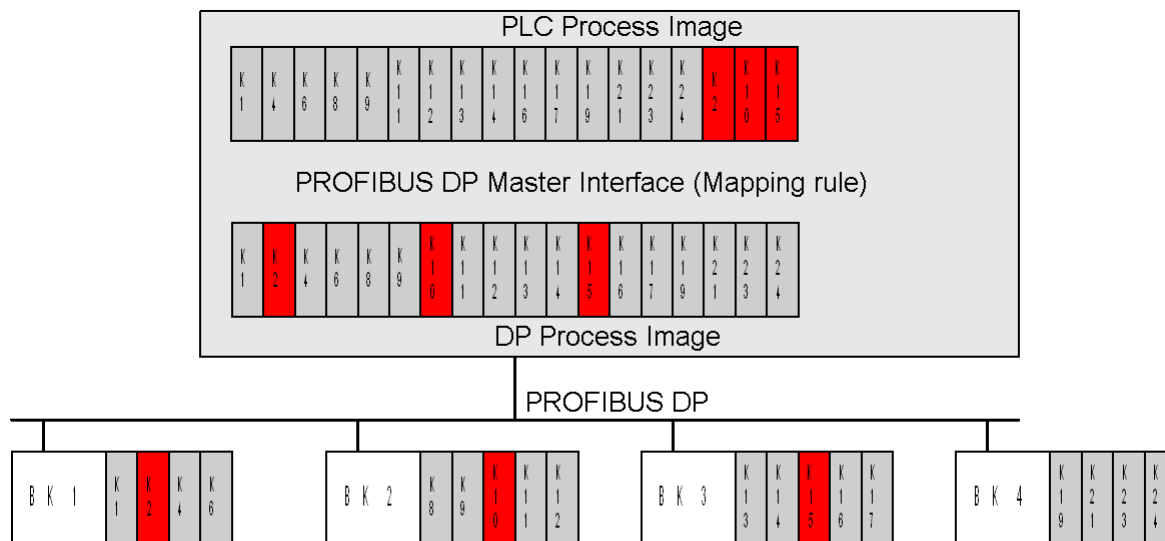

Only Extension B

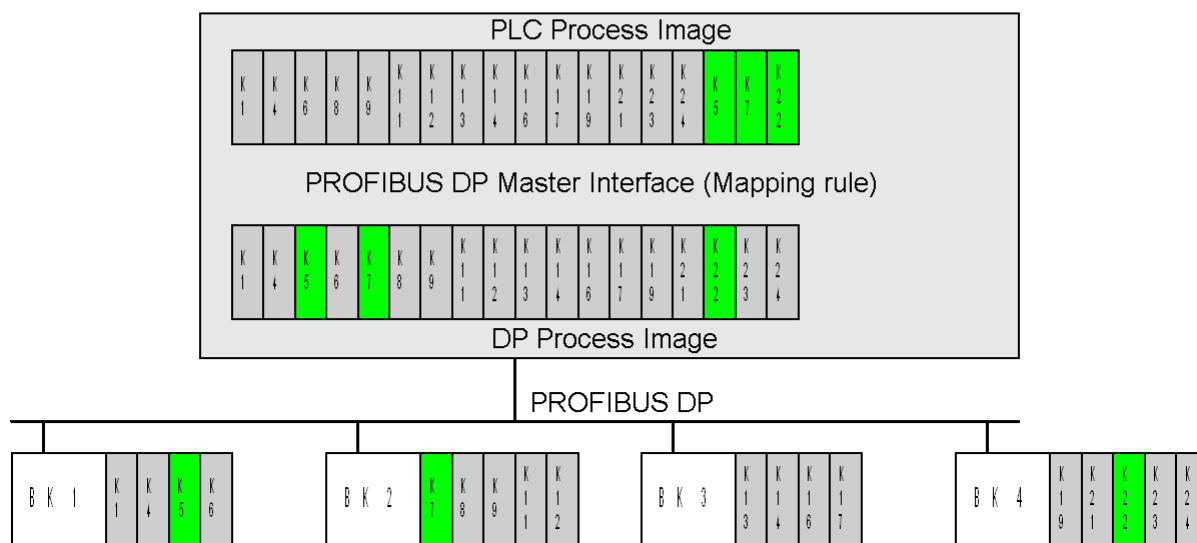

In order to solve the problem of the changed mapping rule, a facility is provided in the BK3110, BK3120 and BK3520 Bus Couplers through which the mapping can be carried out in the Bus Coupler (multi-configuration mode), so that they always exchange the same process image with the PROFIBUS DP master, independently of the Bus Terminals present:

**Setting the Bus Terminal extension in the Bus Coupler**

So that the same process image can always be transferred between the PROFIBUS DP master and the Bus Coupler, independently of the implementation level of the machine or of the Bus Terminals, the maximum Bus Terminal implementation for the Bus Coupler is always configured in the PROFIBUS DP master under multi-configuration mode. This PROFIBUS DP configuration is sent from the PROFIBUS DP master to the Bus Coupler when the PROFIBUS DP bus is starting up. This then compares the received PROFIBUS DP configuration with the bus terminals that are actually present.

If the Bus Coupler is not already being operated with the maximum Bus Terminal implementation level, the PROFIBUS DP configuration will not agree with the Bus Terminal structure that it finds. So that the Bus Coupler can nevertheless represent the process signals from the connected Bus Terminals in the process image that is to be exchanged with the PROFIBUS DP master, the mapping rule is now required.



Because the Bus Coupler maps the process signals from the Bus Terminals into the DP process image according to a fixed algorithm (first complex, then digital terminals, each in the sequence in which they are plugged in), the only information that is missing is that of which of the Bus Terminals that are included in the PROFIBUS DP configuration are indeed truly present. This information can be transmitted via the acyclic DPV1 Write, or through the 2-byte PLC interface for those PROFIBUS DP master interfaces that do not support PROFIBUS DPV1. The acyclic DPV1 Write is usually available through function blocks (TwinCAT: ADS-Write, S7 400: SFB 52 (read) and SFB53 (write)) from the controller program. The 2-byte PLC interface of the Bus Coupler is mapped directly into the controller's process image. As soon as a machine extension is activated or deactivated, the controller program can therefore activate or deactivate the associated Bus Terminals.

Example as above, where deactivated terminals are marked in yellow:

Only Extension A

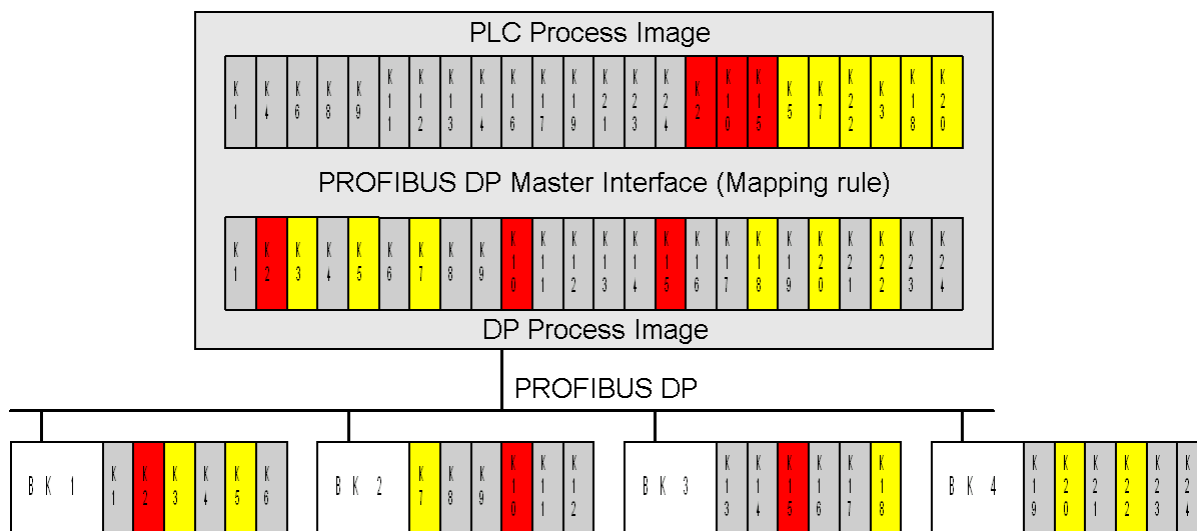

Only Extension B

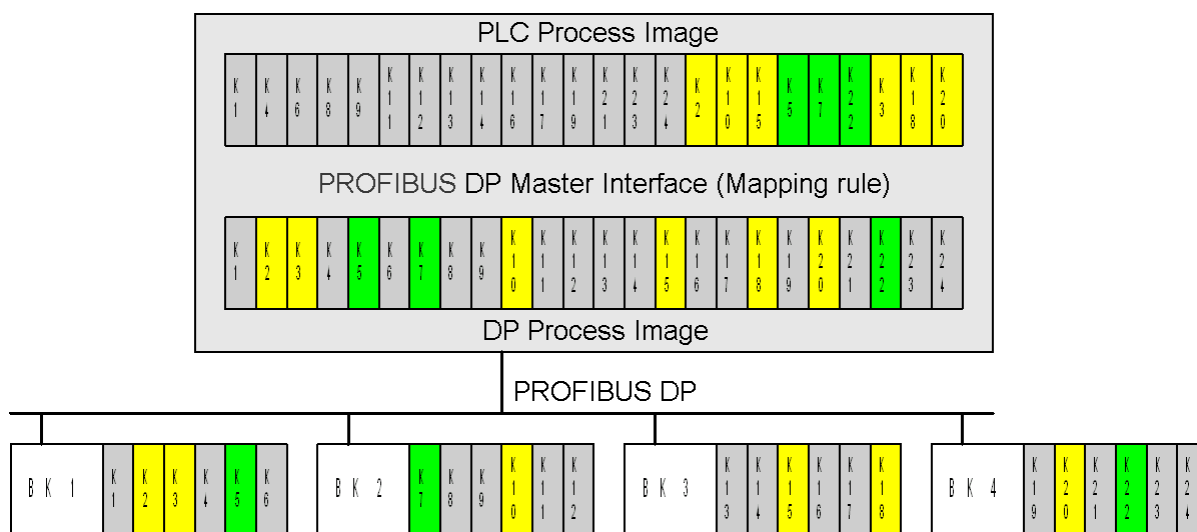

**State transitions in the Bus Coupler**

If the PROFIBUS DP configuration received does match the Bus Terminal configuration in multi-configuration mode, the Bus Coupler sets the "static diagnostics" bit in the PROFIBUS DP diagnostic data and delays the execution of a terminal bus cycle (I/O RUN LED remains off). As soon as the terminal assignment (activated/not activated) has been written by the PROFIBUS DP master, the Bus Coupler again carries out an examination of the PROFIBUS DP configuration, and automatically enters cyclic data exchange (the "static diagnosis" bit in PROFIBUS DP diagnostic data is cleared, and the terminal bus cycle is executed cyclically (the I/O-RUN LED goes on during the terminal cycle)).

Furthermore, the terminal assignment is stored in the non-volatile memory of the Bus Coupler, so that during a restart of the PROFIBUS DP, the PROFIBUS DP master does not have to write the terminal configuration again.

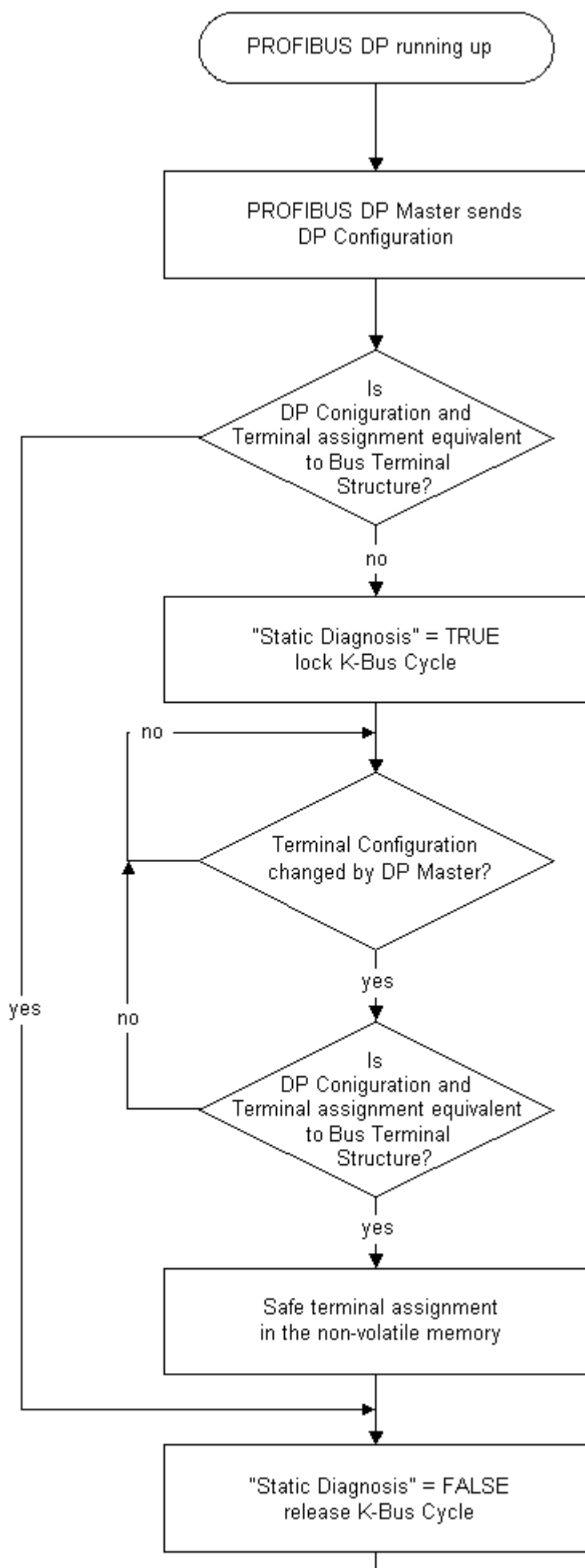

BECKHOFF Fieldbus Components: Appendix

## General Operating Conditions

The following conditions must be observed if the fieldbus components are to function without error.

### Environmental conditions

#### Operation

The components may not be used without additional protection in the following locations:

- in difficult environments, such as where there are corrosive vapors or gases, or high dust levels
- in the presence of high levels of ionizing radiation

Condition	Permissible range
Permissible ambient temperature range during operation	0°C ... +55°C
Permissible relative humidity during operation	95 %, no condensation
Installation position	variable
Vibration resistance	conforms to EN 60068-2-6
Shock resistance	conforms to EN 60068-2-27, EN 60068-2-29
EMC resistance burst	conforms to EN 61000-6-2
ESD emission	conforms to EN 61000-6-4

#### Transport and storage

Condition	Permissible range
Permissible ambient temperature range during storage	-25 °C ... +85°C
Permissible relative humidity	95 %, no condensation
Free fall	up to 1 m in the original packaging

#### Protection classes and types

Condition	Permissible range
Protection class in accordance with IEC 536 (VDE 0106, Part 1)	A protective conductor connection to the mounting rail is necessary!
Protection class according to IEC 529	IP20 (protection against contact with a standard test finger)
Protection against foreign objects	Less than 12 mm in diameter
Protection against water	No protection

### Component identification

Every supplied component includes an adhesive label providing information about the product's approvals. For example, on the BK2000:

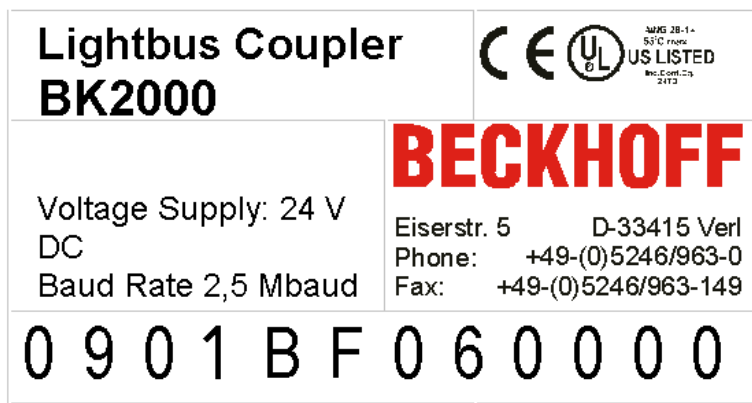

The following information is printed on the label:

Printed item	In this particular example:
Precise product identification	Lightbus Coupler BK2000
Supply voltage $U_s$	24 V <sub>DC</sub> (To meet the UL requirements use 4 A fuse or class 2 power supply!)
Data transfer rate	2.5 Mbaud
manufacturer	Beckhoff Automation GmbH
CE mark	Conformity mark
UL mark	Mark for UL approval. UL stands for the Underwriters Laboratories Inc., the leading certification organization for North America, based in the USA. C = Canada, US = USA, UL File Number: E172151
 Use 4 Amp. fuse or Class 2 power supply. See instructions.	
Production identification	From left to right, this sequence of characters indicates the production week (2 characters), the production year (2 characters), the software version (2 characters) and hardware version (2 characters), along with any special indications (4 characters).  This case therefore is a BK2000 - produced in the 9th calendar week - of the year 2001 - containing the BF firmware version - and using the 6th hardware version - with no special indications

BECKHOFF Fieldbus components: Appendix

## Approvals

UL E172151

## Conformity mark

CE

# Protection class

IP20 in accordance with EN60529

BECKHOFF Fieldbus Components: Appendix

## Bibliography

### German books

#### PROFIBUS

- PROFIBUS-DP/DPV1  
Grundlagen, Tipps und Tricks für Anwender (Principles, Tips for Users)  
by Manfred Popp  
ISBN: 3778527819

#### General fieldbus technology

- Gerhard Gruhler (Pub.): **Feldbusse und Geräte-Kommunikationssysteme** (Fieldbus and Device Communication Systems)  
Praktisches Know-How mit Vergleichsmöglichkeiten (Practical Know-how with Comparative Resources)  
Franzis Verlag, 2001  
244 pages  
ISBN 3-7723-5745-8

### English books

(in preparation)

### PROFIBUS-DP standards

- IEC 61158 and IEC 61784
- DIN 19245, Part 3
- Euronorm EN 50 170

### Web sites

- <http://www.profibus.com>

BECKHOFF Fieldbus Components: Appendix

## List of Abbreviations

#### DP

Distributed Peripherals. PROFIBUS protocol for fast cyclic data exchange

**FMS**

Fieldbus Message Specification. The PROFIBUS transmission protocol

**Freeze mode**

This command makes the slave freeze its inputs

**GSD file**

Basic device file (in German)

**GSE file**

Basic device file (in English)

**IP20, IP65, IP66, IP67**

Protection class (contact, water, dust)

**K-Bus**

Terminal bus - internal bus for communication between the coupler and Bus Terminals

**PNO**

PROFIBUS User Organisation

**Repeater**

Provides signal conditioning, connecting individual bus segments

**PLC**

Programmable logic controller

**Sync mode**

This command makes the slave hold its outputs unchanged until it receives the Sync telegram.

BECKHOFF Automation: Appendix

## Support and Service

Beckhoff and their partners around the world offer comprehensive support and service, making available fast and competent assistance with all questions related to Beckhoff products and system solutions.

### Beckhoff Support

Support offers you comprehensive technical assistance, helping you not only with the application of individual Beckhoff products, but also with other, wide-ranging services:

- world-wide support
- design, programming and commissioning of complex automation systems

- and extensive training program for Beckhoff system components

Hotline: +49(0)5246/963-157

Fax: +49(0)5246/963-9157

e-mail: [support@beckhoff.com](mailto:support@beckhoff.com)

## Beckhoff Service

The Beckhoff Service Center supports you in all matters of after-sales service:

- on-site service
- repair service
- spare parts service
- hotline service

Hotline: +49(0)5246/963-460

Fax: +49(0)5246/963-479

e-mail: [service@beckhoff.com](mailto:service@beckhoff.com)

You will find further support and service addresses on our Internet pages under <http://www.beckhoff.com>.

## Beckhoff Headquarters

Beckhoff Automation GmbH

Eiserstr. 5

33415 Verl

Germany

Phone: +49(0)5246/963-0

Fax: +49(0)5246/963-198

e-mail: [info@beckhoff.com](mailto:info@beckhoff.com)

The addresses of Beckhoff's branch offices and representatives round the world can be found on her internet pages:

<http://www.beckhoff.com>

You will also find further documentation for Beckhoff components there.