

Danfoss code	Typecode	Ohm	L±2 mm	L±0.08 in	L1±2 mm	L1±0.04 in	Weight kg
175U3032	MCE101A42R0P1K70E21TAW	42	460	18.11	360	14.17	9.2
175U3037	MCE101A31R0P1K70E21TAW	31	460	18.11	360	14.17	9.2
175U3039	MCE101A28R0P1K40E21TAW	28	400	15.75	300	11.81	8.2
175U3043	MCE101A27R0P2K20E21TAW	27	560	22.05	460	18.11	11
175U3047	MCE101A22R0P1K70E21TAW	22	460	18.11	360	14.17	9.2
175U3049	MCE101A19R0P2K20E21TAW	19	560	22.05	460	11.81	11
175U3055	MCE101A14R0P2K80E21TAW	14	660	25.98	560	22.05	12.8
175U3061	MCE101A12R0P3K20E21TAW	12	760	29.92	660	25.98	14.6
175U3073	MCE101A5R70P1K40E21TAW	5.7	400	15.75	300	11.81	8.2
175U3080	MCE101A3R50P2K20E21TAW	3.5	560	22.05	460	11.81	11
175U3086	MCE101A2R80P3K20E21TAW	2.8	760	29.92	660	25.98	14.6
175U3106	MCE101A145R2K20E21TAW	145	560	22.05	460	11.81	11
175U3122	MCE101A200R1K70E21TAW	200	460	18.11	360	14.17	9.2
175U3126	MCE101A145R1K70E21TAW	145	460	18.11	360	14.17	9.2
175U3130	MCE101A110R2K20E21TAW	110	560	22.05	460	18.11	11
175U3132	MCE101A105R3K20E21TAW	105	760	29.92	660	25.98	14.6
175U3138	MCE101A80R0P2K20E21TAW	80	560	22.05	460	18.11	11
175U3140	MCE101A72R0P2K80E21TAW	72	660	25.98	560	22.05	12.8
175U3146	MCE101A56R0P2K80E21TAW	56	660	25.98	560	22.05	12.8
175U3152	MCE101A48R0P1K40E21TAW	48	400	15.75	300	11.81	8.2
175U3160	MCE101A35R0P1K70E21TAW	35	460	18.11	360	14.17	9.2
175U3168	MCE101A27R0P2K20E21TAW	27	560	22.05	460	18.11	11
175U3172	MCE101A18R0P3K20E21TAW	18	760	29.92	660	25.98	14.6
175U3410	MCE101A27R0P1K40E21TAW	27	400	15.75	300	11.81	8.2
175U3412	MCE101A18R0P2K20E21TAW	18	560	22.05	460	18.11	11
175U3414	MCE101A13R0P3K20E21TAW	13	760	29.92	660	25.98	14.6
175U3424	MCE101A110R1K70E21TAW	110	460	18.11	360	14.17	9.2
175U3428	MCE101A56R0P3K20E21TAW	56	760	29.92	660	25.98	14.6
175U3438	MCE101A100R2K20E21TAW	100	560	22.05	460	18.11	11
175U3440	MCE101A72R0P3K20E21TAW	72	760	29.92	660	25.98	14.6
175U3446	MCE101A5R70P1K40E21TAW	5.7	400	15.75	300	11.81	8.2
175U3448	MCE101A3R50P2K80E21TAW	3.5	660	25.98	560	22.05	12.8
175U3460	MCE101A38R0P1K40E21TAW	38	400	15.75	300	11.81	8.2
175U3462	MCE101A19R0P2K80E21TAW	19	660	25.98	560	22.05	12.8
175U3464	MCE101A14R0P3K20E21TAW	14	760	29.92	660	25.98	14.6
175U3468	MCE101A52R0P1K40E21TAW	52	400	15.75	300	11.81	8.2
175U3470	MCE101A31R0P2K20E21TAW	31	560	22.05	460	18.11	11
175U3472	MCE101A27R0P2K80E21TAW	27	660	25.98	560	22.05	12.8
175U3479	MCE101A22R0P3K20E21TAW	22	760	29.92	660	25.98	14.6
175U3483	MCE101A5R70P1K70E21TAW	5.7	460	18.11	360	14.17	9.2

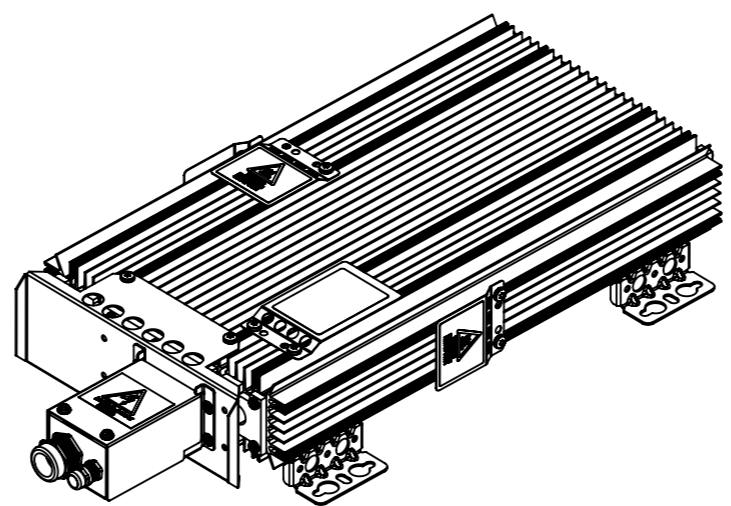
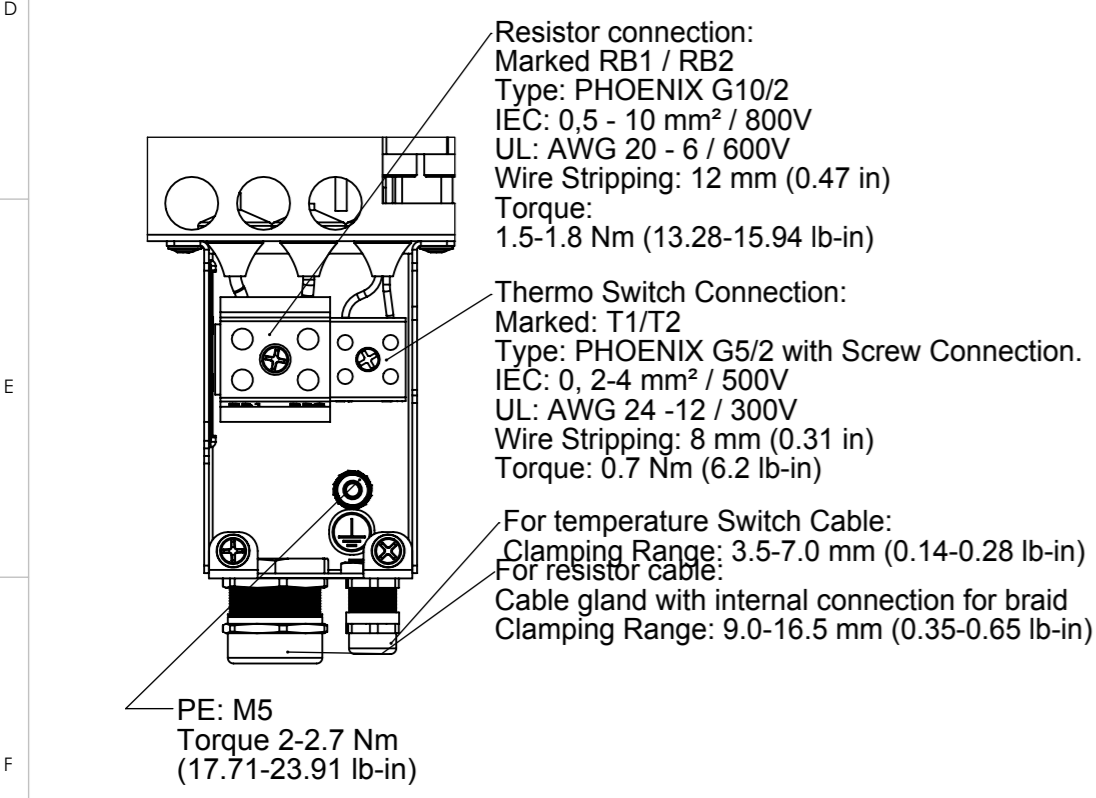

Danfoss Danfoss A/S
Power Electronics Division
Ulsnæs 1, 6300 Graasten
Denmark

MCE 101 Brake Resistor
xxR ± 10% 914 IP21/20
175C0633

Weight (g)	Date	Creator:	Approved:	Scale
-	27.08.2010	OC	PM	1:3
Tolerance:	-	File: 914CBT-HxxxDHT		
No.:	Last Revision:	Rev Date:	By:	Paper size:
5	175U3106 added	18.12.2012	HEE	A3

Any amendment must be confirmed by DANOTHERM ELECTRIC A/S

Material: Drawing No.: **914CBT-HxxxDHT** Sheet: 1 of 1

Path: T:\sw\kute\KUTETEGN\

This drawing is the property of DANOTHERM ELECTRIC A/S and must not be copied without their consent.