

Now with selectable
Plug-in technology

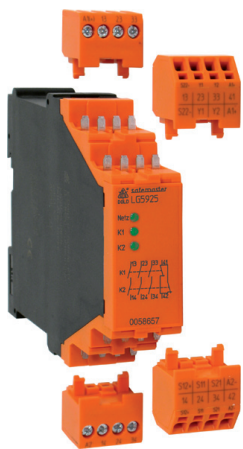

- According to
 - Performance Level (PL) d and category 3 to EN ISO 13849-1: 2008
 - SIL Claimed Level (SIL CL) 2 to IEC/EN 62061
 - Safety Integrity Level (SIL 2) to IEC/EN 61508
 - Category 3 to EN 954-1
- Single channel operation
- Output: max. 4 NO contacts
- AC 230 V model with galvanic separation
- LED indicator for channel 1 / 2 and state of operation
- Short circuit detection between terminal Y1 and common
- Wire connection: also 2 x 1.5 mm² stranded ferruled, or 2 x 2.5 mm² solid DIN 46 228-1/-2/-3/-4
- as option with pluggable terminal blocks for easy exchange of devices
 - with screw terminals
 - or with cage clamp terminals
- Width 22.5 mm

Options with pluggable terminal blocks



LG _ _ _ _ P _

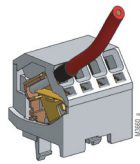

Terminal block with cage clamp terminals (PC / plugin cageclamp)

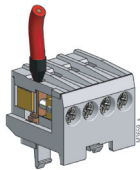

Terminal block with screw terminals (PS / plugin screw)

Approvals and marking



¹⁾ see variants;

Applications

- Protection of people and machines
- Emergency stop circuits on machines

Indicators

LED Phase: on, when supply connected
LED K1/K2: on, when relay K1 and K2 energized

Indicators

ATTENTION - AUTOMATIC START!



According to IEC/EN 60 204-1 part 9.2.5.4.2 and 10.8.3 it is not allowed to restart automatically after emergency stop. Therefore the machine control has to disable the automatic start after emergency stop.

Notes

Removing the terminal blocks with cage clamp terminals

1. The unit has to be disconnected.
2. Insert a screwdriver in the side recess of the front plate.
3. Turn the screwdriver to the right and left.
4. Please note that the terminal blocks have to be mounted on the belonging plug in terminations.

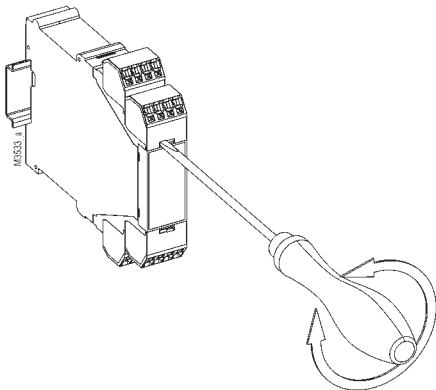

Function diagram

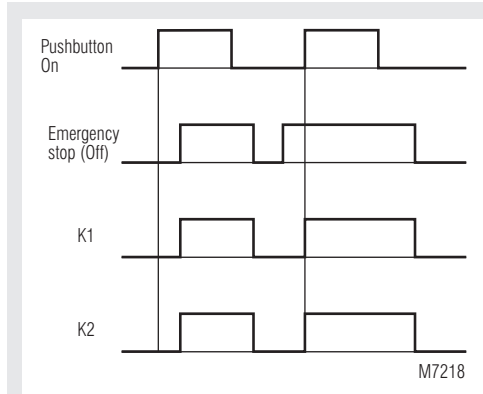

Block diagrams

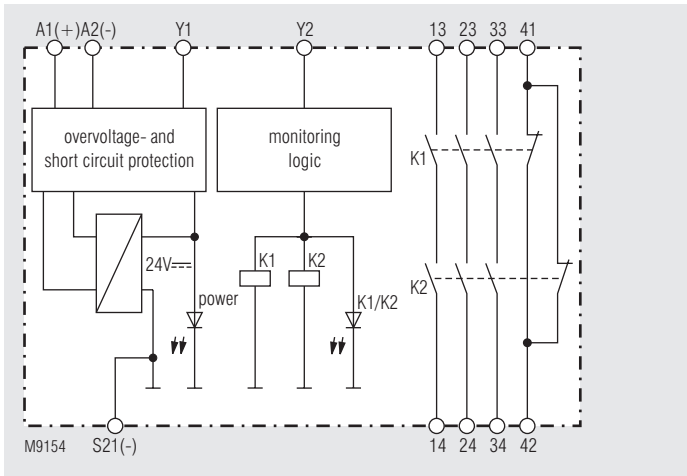

LG 5924.48

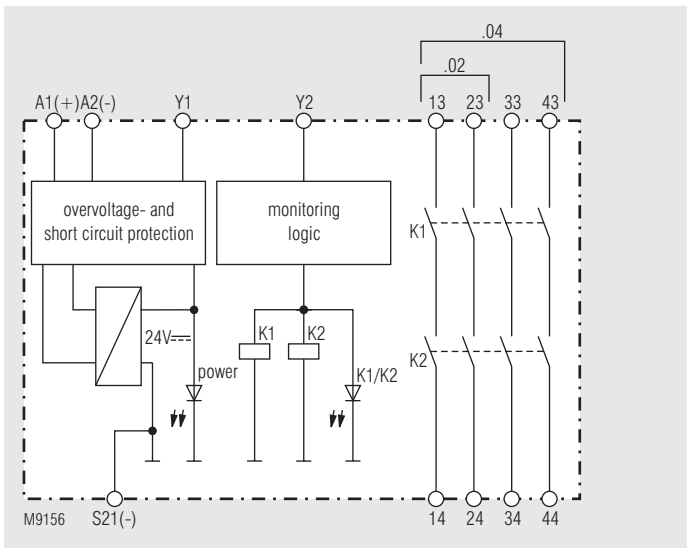

LG 5924.02, LG 5924.04

Circuit diagrams

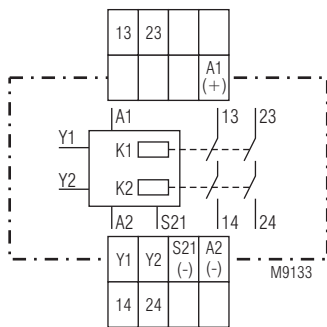

LG 5924.02

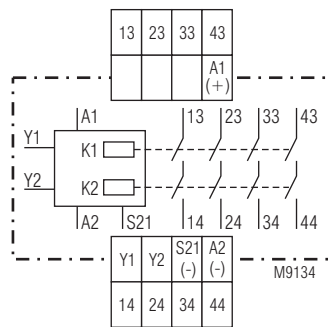

LG 5924.04

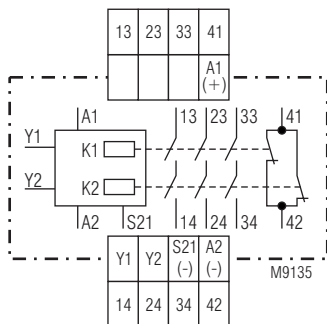

LG 5924.48

Technical Data

Input

Nominal voltage U_N:	DC 24 V AC 110, 230 V
Nominal frequency:	50 / 60 Hz
Voltage range:	AC 0.85 ... 1.1 U_N DC 0.9 ... 1.1 U_N
Nominal consumption	
DC 24 V:	DC 1.5 W
AC 230 V:	3.5 VA
Control voltage on Y1	
DC 24 V:	typ. DC 22 V
AC 230 V:	typ. DC 45 V
Control current	
DC 24 V:	typ. DC 65 mA
AC 230 V:	typ. AC 16 mA
Recovery time:	0.5 s

Output

Contacts

LG 5924.02:	2 NO contacts
LG 5924.04:	4 NO contacts
LG 5924.48:	3 NO, 1 NC contacts
	The NO contacts are safety contacts.
	ATTENTION! The NC contacts 41-42 can only be used for monitoring.

Operate delay

DC 24 V:	typ. DC 40 ms
AC 230 V:	typ. AC 200 ms

Release delay

AC/DC 24 V:	typ. DC 70 ms
AC 230 V:	typ. AC 35 ms

Contact type:

positive guided
max. 5 A (see quadratic total current limit curve)
AC 250 V

Nominal output voltage:

Switching capacity

to AC 15		IEC/EN 60 947-5-1
NO contact:	3 A / AC 230 V	
NC contact:	2 A / AC 230 V	
to DC 13		
NO contact:	4 A / 24 V	
	0.5 A / 110 V	
	4 A / 24 V	

NC contact

Electrical life

at 5 A, AC 230 V $\cos \varphi = 1$:
according to DC 13

NO contacts

2 contacts in series:

Permissible operating frequency:

Short circuit strength

max. fuse rating:

line circuit breaker:

Mechanical life:

General Data

Operating mode:

Temperature range

operation: - 15 ... + 55 °C

storage: - 25 ... + 85 °C

altitude:

< 2.000 m

Clearance and creepage distances

rated impuls voltage /

pollution degree:

4 kV / 2 (basis insulation) IEC 60 664-1

EMC

Electrostatic discharge:

HF irradiation:

Fast transients:

Surge voltages

between wires for

power supply:

between wire and ground:

HF wire guided:

Interference suppression

Degree of protection

Housing:

Terminals:

Housing:

Continuous operation

Technical Data

Vibration resistance:	Amplitude 0.35 mm frequency 10 ... 55 Hz, IEC/EN 60 068-2-6 15 / 055 / 04 IEC/EN 60 068-1
Climate resistance:	
Terminal designation:	EN 50 005
Wire connection	DIN 46 228-1/-2/-3/-4
Screw terminals	
(integrated):	1 x 4 mm ² solid or 1 x 2.5 mm ² stranded ferruled or 2 x 1.5 mm ² stranded ferruled or 2 x 2.5 mm ² solid
Insulation of wires or sleeve length:	8 mm
Plugin with screw terminals	
max. cross section for connection:	1 x 2.5 mm ² solid or 1 x 2.5 mm ² stranded ferruled
Insulation of wires or sleeve length:	8 mm
Plugin with cage clamp terminals	
max. cross section for connection:	1 x 4 mm ² solid or 1 x 2.5 mm ² stranded ferruled
min. cross section for connection:	0.5 mm ²
Insulation of wires or sleeve length:	12 ±0.5 mm
Wire fixing:	Plus-minus terminal screws M 3.5 box terminals with wire protection or cage clamp terminals
Mounting:	DIN rail IEC/EN 60 715
Weight	
LG 5924, DC 24 V:	200 g
LG 5924, AC 230 V:	270 g

Dimensions

Width x height x depth

LG 5924:	22.5 x 90 x 121 mm
LG 5924 PC:	22.5 x 111 x 121 mm
LG 5924 PS:	22.5 x 104 x 121 mm

Safety related data

Values according to EN ISO 13849-1:

Category:	3	
PL:	d	
MTTF _d :	180,3	a
DC _{avg} :	99,0	%
d _{op} :	365	d/a (days/year)
h _{op} :	24	h/d (hours/day)
t _{Zyklus} :	3600	s/Zyklus
	± 1	/h (hour)

Values according to IEC/EN 62061 / IEC/EN 61508:

SIL CL:	2	IEC/EN 62061
SIL	2	IEC/EN 61508
HFT ¹⁾ :	1	
DC _{avg} :	99,0	%
SFF	99,7	%
PFH _D :	2,60E-10	h ⁻¹

¹⁾ HFT = Hardware-Failure Toleranz



The values stated above are valid for the standard type.
Safety data for other variants are available on request.

The safety relevant data of the complete system has to be
determined by the manufacturer of the system.

UL-Data

The safety functions were not evaluated by UL. Listing is accomplished according to requirements of Standard UL 508, "general use applications"

Nominal voltage U_N: DC 24 V
AC 110, 230 V

Ambient temperature: -15 ... +55°C

Switching capacity:
Ambient temperature 45°C: Pilot duty B300
5A 250Vac Resistive
5A 24Vdc Resistive or G.P.
Ambient temperature 55°C: Pilot duty B300
4A 250Vac Resistive
4A 24Vdc Resistive or G.P.

Wire connection: 60°C / 75°C copper conductors only
Screw terminals fixed: AWG 20 - 12 Sol/Str Torque 0.8 Nm
Plugin screw: AWG 20 - 14 Sol Torque 0.8 Nm
AWG 20 - 16 Str Torque 0.8 Nm
Plugin cage clamp: AWG 20 - 12 Sol/Str



Technical data that is not stated in the UL-Data, can be found
in the technical data section.

Standard type

LG 5924.48 DC 24 V	
Article number:	0058335
• Output:	3 NO, 1 NC contacts
• Nominal voltage U _N :	DC 24 V
• Width:	22.5 mm

Ordering example

LG 5924. __ / 61: with UL approval

Ordering example for variant

LG 5924 .48 _ _ /61 DC 24 V

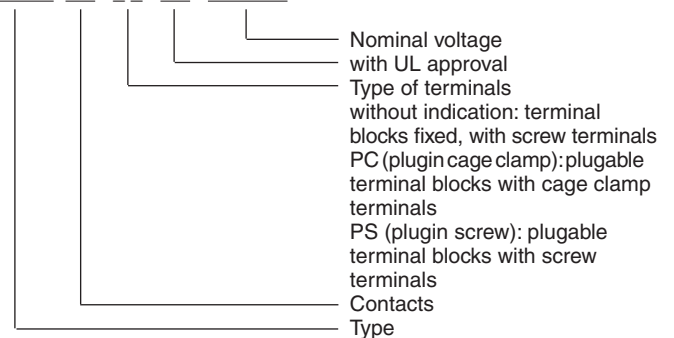

Characteristics

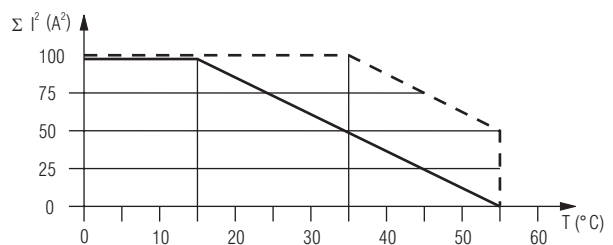

--- device mounted away from
heat generation components.
max. current at 55°C over
4 contactrows = $3,5A \hat{=} 4 \times 3,5^2 A^2 = 49A^2$

— device mounted without distance heated by
devices with same load,
max. current at 55°C over
4 contactrows = $1A \hat{=} 4 \times 1^2 A^2 = 4A^2$

$$\Sigma I^2 = I_1^2 + I_2^2 + I_3^2 + I_4^2$$

Quadratic total current limit curve

Application examples

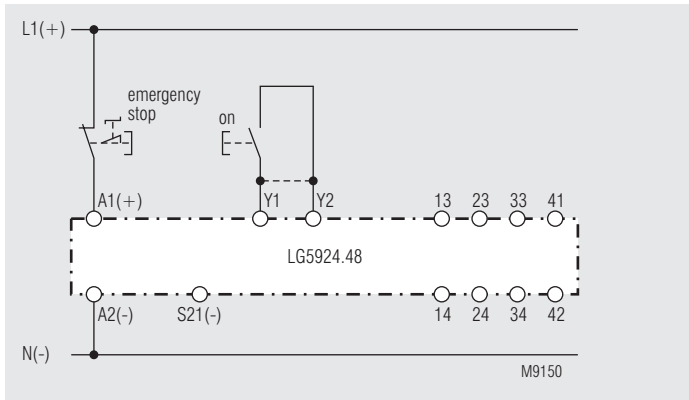

Single channel emergency-stop circuit without feed back loop, with or without automatic restart.

For automatic restart terminals Y1-Y2 must be linked.

No ON-pushbutton necessary.

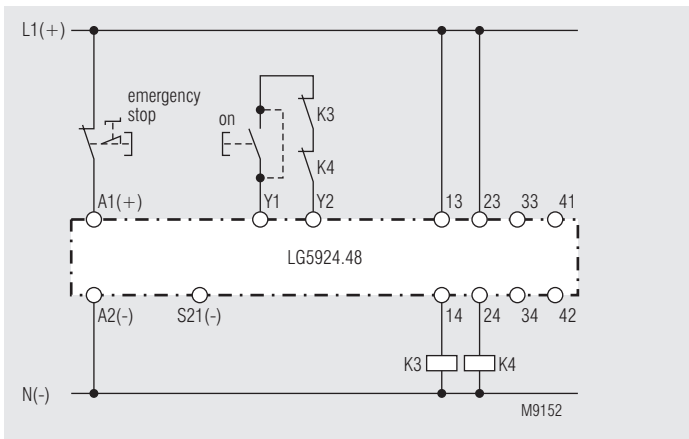

Contact reinforcement by external contactors, 2-channel controlled. For currents > 5 A the output contacts can be reinforced by external contactors. Functioning of the external contactors is monitored by looping the NC contacts into the start circuit (Y1-Y2).