

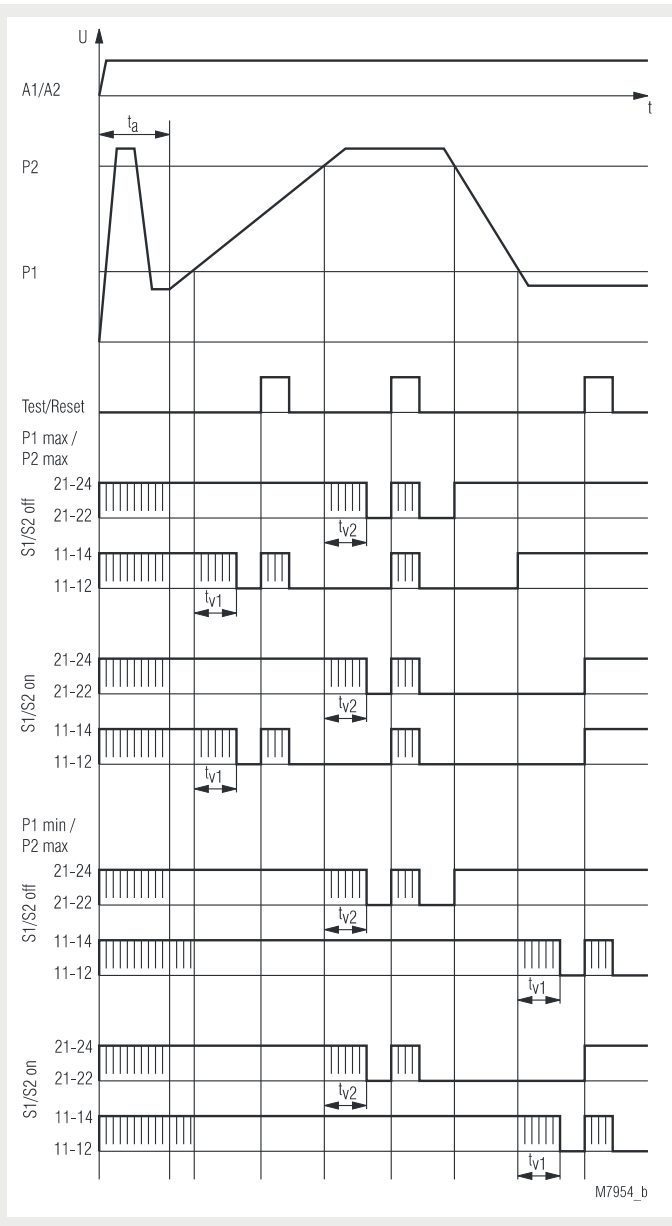

0239914

- According to IEC/EN 60 255, DIN/VDE 0435-303
- Identification of
 - Underload P_1 and Overload P_2
 - Overload P_1 (prewarning) and Overload P_2 programmable
- Adjustment of P_1 and P_2 on absolute scale
- For motors up to 22 kW / 400 V; 37 kW / 600 V
- Measurement: effective power
- Large current range because of automatic range selection
- 1 changeover contact for P_1 and 1 changeover contact for P_2
- Adjustable start-up delay t_a
- Adjustable switching delay t_v
- With automatic or manual reset, programmable
- Test / Reset button for easy setup
- Up to 40 A without external current transformer
- De-energized or energized on fault, programmable
- Also for single-phase operation
- LED indicators
- Width 45 mm

Function Diagram for Setting De-energized on Fault*)



M7954_b

P1max/P2max: Overload monitoring with prewarning
 P1min/P2max: Under- and overload monitoring
 S1/S2 ON: manual reset
 S1/S2 OFF: automatic reset
 IIIII: corresponding LED is flashing

*) when set to energized on fault the function of LEDs and output relays are inverted.

Approvals and Marking



Applications

The BH 9097 is used to monitor variable loads on industrial motors.

Function

The motor load monitor BH 9097 checks the active power consumption of electrical consumers. As the measuring principle is only single phase correct measurement of 3-phase load is only possible when all three phases have the same load which is normal with motors. Using DIP-switches the unit can be set up to act as under- and overload relay P_{1min}/P_{2max} , or as overload relay with pre-warning P_{1max}/P_{2max} . The settings of P_1 and P_2 are absolute values and calibrated in Watts adjustable via rotational switches. 2 LEDs show the state of the corresponding output relays. The unit can be configured to energise or to de-energise on fault. Every output relay is fitted with it's own time delay t_v . A start-up delay t_a acts on both outputs.

Indication

green LED, U_N :	flashing:	during Start-up delay t_a
	continuous:	supply connected
yellow LED, P_1 :	flashing:	during time delay t_{v1} and for set up assistance
	continuous:	when relay P_1 active (contact 11-14)
yellow LED, P_2 :	flashing:	during time delay t_{v2} and for set up assistance
	continuous:	when relay P_2 active (contact 21-24)

Fault indication

2 different faults are displayed with the LEDs.

1.) No measurement:

Without measuring voltage measurement is not possible
 - All 3 LEDs flash in sequence one after the other.
 The output contacts are in failure state.

2.) The BH 9097 measures negative load:

Possible reason: The unit measures reverse power or the current connections are connected wrong.
 - All 3 LEDs flash simultaneously.

Connection Diagrams

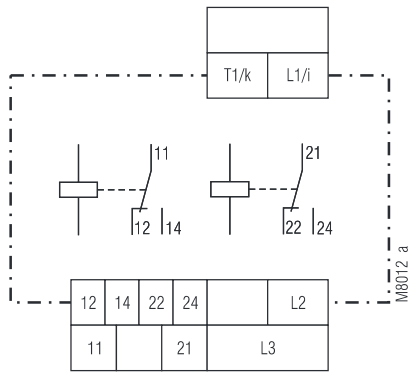

BH 9097.38/001

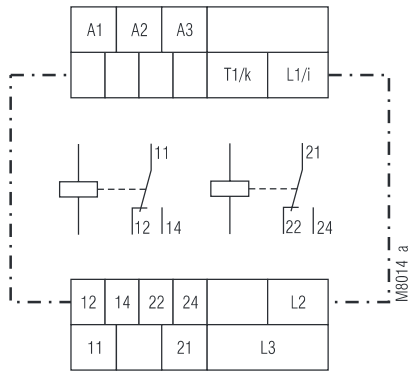

BH 9097.38/011

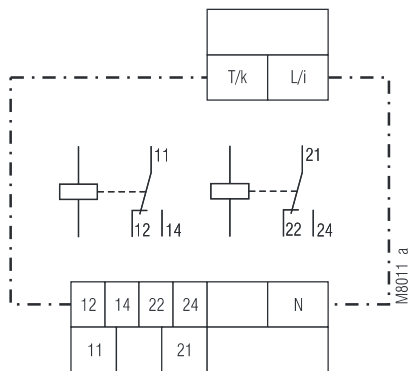

BH 9097.38

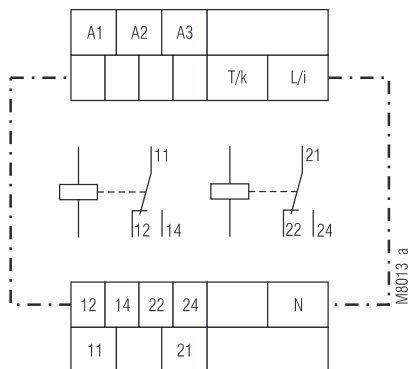

BH 9097.38/010

Technical Data

Input

Measuring voltage

Voltage range:

without auxiliary voltage $0.8 \dots 1.1 \times U_N$
with auxiliary voltage, see setting ranges
300 k Ω ... 500 k Ω

Input resistance:

Measuring current

Measuring range:

see setting ranges

Nominal current [A]

Permissible current range

(overload) [A]

continuously:

1 min. (10 min. break):

20 s (10 min. break):

Input res. of current on i-k [m Ω]:

	40	24	8	2.4	0.8	0.24
0 ... 40	0 ... 40	0 ... 16	0 ... 8	0 ... 2.4	0 ... 1	0 ... 1
150	150	20	16	3	1.5	
200	200	25	20	4	2	
≤ 1	≤ 1	7	14	830	830	

Frequency range:

10 ... 400 Hz

(please see characteristics M7953)

Setting Ranges

P₁ und P₂ on absolute scale

Switch

load range

for P₁ and P₂:

lower range

upper range



Measuring accuracy

(in % of setting value):

$\pm 4 \%$ (2 % on request)

Hysteresis

(in % of setting value):

< 5 %

Harmonic distortion

< 40 %

Reaction time:

< 50 ms

Switching delay t_{v1}/t_{v2} :

0 ... 10 s (infinite variable)

Start-up delay t_a :

0 ... 30 s (infinite variable)

Setting Ranges

Available variants

Measuring voltage U_N

Measuring current I_N [A]

selection of load range

1-phase

without auxiliary voltage

BH 9097.38/000

AC 230 V

0.0024 ... 0.24

0.1 ... 60 W

AC 230 V

0.024 ... 2.4

1 ... 600 W

AC 230 V

0.24 ... 24

10 ... 6000 W

with auxiliary voltage

BH 9097.38/010

AC 35...250 V

0.0024 ... 0.24

0.1 ... 60 W

AC 35...250 V

0.024 ... 2.4

1 ... 600 W

AC 35...250 V

0.24 ... 24

10 ... 6000 W

3-phase

without auxiliary voltage

BH 9097.38/001

3 AC 400 V

0.008 ... 0.8

0.1 ... 60 W

3 AC 400 V

0.08 ... 8

10 ... 6000 W

3 AC 400 V

0.4 ... 40

0.1 ... 30 kW

with auxiliary voltage

BH 9097.38/011

3 AC 60 ... 440 V

0.008 ... 0.8

1 ... 600 W

3 AC 60 ... 440 V

0.08 ... 8

10 ... 6000 W

3 AC 100 ... 760 V

0.4 ... 40

0.1 ... 52 kW

Auxiliary Circuit

Auxiliary voltage U_H

only for BH 9097.38/010,

BH 9097.38/011:

AC 110 V (Klemmen A 1 - A 2),

AC 230 V (Klemmen A 1 - A 3),

DC 24 V

Voltage range:

0.8 ... 1.1 U_H

Frequency range of U_H :

45 ... 400 Hz

Input current

AC 110 V:

approx. 30 mA

AC 230 V:

approx. 15 mA

DC 24 V:

approx. 50 mA

Technical Data

Output

Contacts:	1 changeover contact for P1 1 changeover contact for P2	
Thermal current I_{th} :	2 x 5 A	
Switching capacity to AC 15	3 A / AC 230 V	IEC/EN 60 947-5-1
NO contact:	1 A / AC 230 V	IEC/EN 60 947-5-1
NC contact:	1 A / DC 24 V	IEC/EN 60 947-5-1
Electrical life to AC 15 at 3 A, AC 230 V:	2 x 10 ⁵ switching cycles	IEC/EN 60 947-5-1
Permissible switching frequency:	1800 switching cycles / h	
Short circuit strength max. fuse rating:	4 A gl IEC/EN 60 947-5-1	
Mechanical life:	30 x 10 ⁶ switching cycles	

General Data

Operating mode:	continuous	
Temperature range:	- 20 ... + 55°C	
Clearance and creepage distances		
rated impuls voltage / pollution degree:	4 kV / 2	IEC 60 664-1
EMC		
Electrostatic discharge:	8 kV (air)	IEC/EN 61 000-4-2
HF-irradiation:	10 V / m	IEC/EN 61 000-4-3
Fast transients:	2 kV	IEC/EN 61 000-4-4
Surge voltages between wires for power supply:	1 kV	IEC/EN 61 000-4-5
between wire and ground:	2 kV	IEC/EN 61 000-4-5
HF-wire guided:	10 V	IEC/EN 61 000-4-6
Interference suppression:	Limit value class B	EN 55 011
Degree of protection		
Housing:	IP 40	IEC/EN 60 529
Terminals:	IP 20	IEC/EN 60 529
Housing:	Thermoplastic with V0 behaviour according to UL subject 94	
Vibration resistance:	Amplitude 0,35 mm frequency 10 ... 55 Hz IEC/EN 60 068-2-6	
Climate resistance:	20 / 055 / 04 IEC/EN 60 068-1	
Terminal designation:	EN 50 005	
Wire connection		
Load terminals:	1 x 10 mm ² solid or 1 x 6 mm ² stranded wire with sleeve	
Control terminals:	1 x 4 mm ² solid or 2 x 1,5 mm ² stranded wire with sleeve or 1 x 2,5 mm ² stranded wire with sleeve DIN 46 228-1/-2/-3/-4	
Wire fixing:	Box terminals with self-lifting wire protection and Plus-minus terminal screws M3.5	
Mounting:	DIN rail	IEC/EN 60 715
Weight:	430 g	

Dimensions

Width x height x depth: 45 x 84 x 121 mm

Standard Type

BH 9097.38/001	3 AC 400 V	50 / 60 Hz	t_a 30 s	t_v 10 s
Article number:	0053944			
• 3-phase, without auxiliary supply				
• Output:	1 changeover contact for P1 and 1 changeover contact for P2			
• Nominal voltage U_N :	3 AC 400 V			
• Width:	45 mm			

Variants

BH 9097.38/001:	3-phase without auxiliary supply
BH 9097.38/011:	3-phase with auxiliary supply
BH 9097.38/000:	1-phase without auxiliary supply
BH 9097.38/010:	1-phase with auxiliary supply
BH 9097.38/1__:	With galvanically separated current path. For applications with current transformers grounded on the secondary side, current range limited to 25 A
BH 9097.38/801:	same as BH 9097.38/001, but with start up delay $t_a = 0 \dots 10$ s

Ordering example for variants

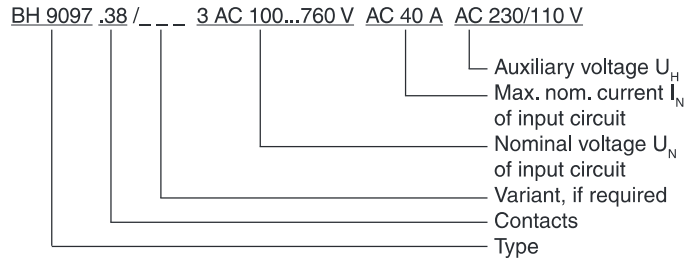

Characteristics

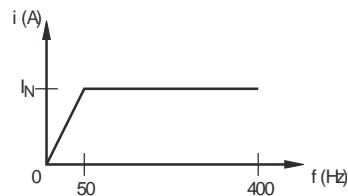

Max. input current curve in relation to input frequency

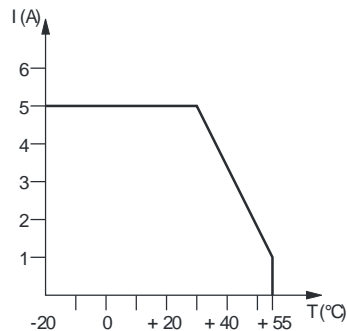

continuous current limit curve (current over 2 contacts)

Settings

2 rotational switches for P₁: Value P₁ (2 decades)
 2 rotational switches for P₂: Value P₂ (2 decades)
 Potentiometer t_{v1}: time delay for value P₁
 Potentiometer t_{v2}: time delay for value P₂
 Potentiometer t_a: start-up delay after connection voltage
 Test/Reset-Taste: Test function as setting assistance
 Reset function when manual reset is selected

Dip-switches:



x10 | x1
 A | R

selection of upper / lower load range
 selection of closed or open circuit operation for output relays

P_{2 max.} | P_{2 max.}
 P_{1 max.} | P_{1 min.}

2 MAX switching values (Overload with Pre-warning) or MAX and MIN switching value (Overload / Underload monitoring)

S1 ON | OFF:

manual / automatic reset for P₁

S2 ON | OFF:

manual / automatic reset for P₂

Connection

The device has to be connected according to the connection diagrams. The motor is connected to terminals L/i and T/k or L1/i and T1/k. The flow direction of the current has to be observed. On reverse power the unit gives a fault signal. The max continuous motor current is 40 A limited by the terminals. With higher currents a current transformer with 2,5 VA has to be used.

Set-up Procedure and Setting Instructions

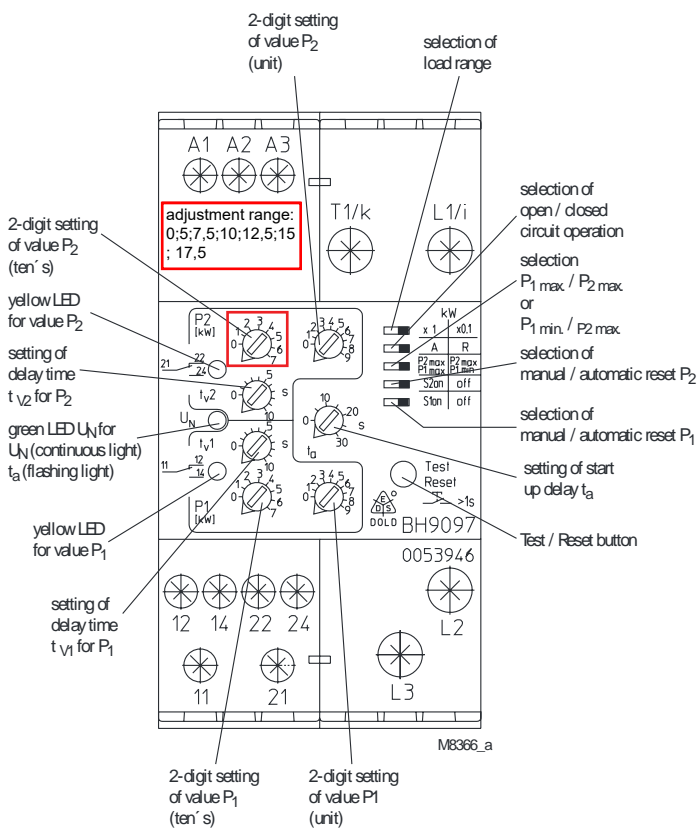

Adjustment example: response value: 2,5 kW

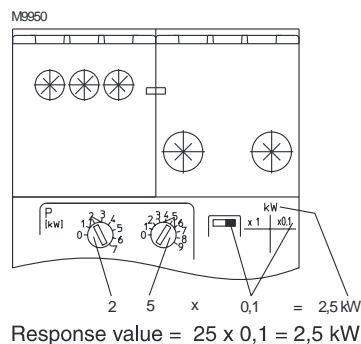

The adjustment of the unit can be made without additional measuring equipment and calculations. Please make sure that the load values are in the permitted operating range of the unit. Based on the max permitted values the BH 9097 can be used for 48 kW 3-phase motors at 3 AC 690 V and 5.8 kW single phase motors at AC 230 V.

There are three methods to set up the unit:

Method 1:

If the absolute values of the actual required tripping points P₁ and P₂ are known, they can be set directly on the unit (2-digit setting of P₁ and P₂).

Method 2:

This method is recommended when it is possible to simulate the different load situations during set-up. In this case nothing has to be calculated. Turn the delay time for P₁ and P₂ to min. The motor runs in underload while the Pot 1 is turned until the output relay switches. The same has to be done for overload. Now the unit is set accurately. Now adjust the operate delay and the start-up delay to the required values.

Pressing the test / reset button during setup disables the switching of the output relays. The LEDs of P₁ and P₂ flash.

Method 3:

This method is the most simple one but not the most accurate. The operate delay is set to min. The motor is switched on and runs on nominal load. With both potentiometers the set points are searched by slowly turning the max. Pot from high to low value and the min. Pot from low to high value until the corresponding output relays switch. After that turn the Pot P₂ to the right (e.g. + 10 %) and the Pot P₁ to the left (e.g. - 10 %) until the output relays reset. The unit is now set and responds if the load differs from the nominal value. Finally set the operate delay and start-up delay to the required values. The DIP switch should be set to P_{1 min.} / P_{2 max.}*

Connection Examples

single phase

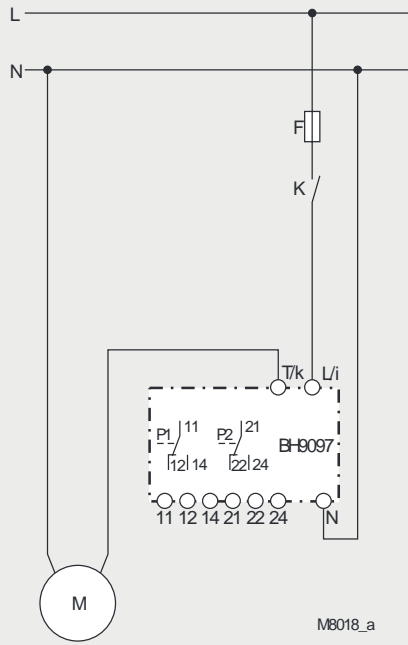

BH 9097.38

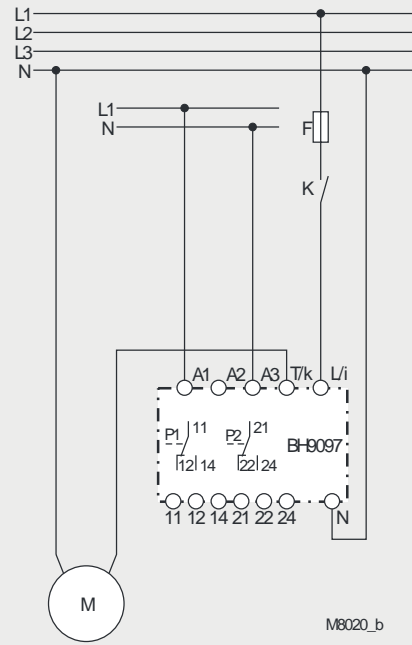

BH 9097.38/010

3-phase

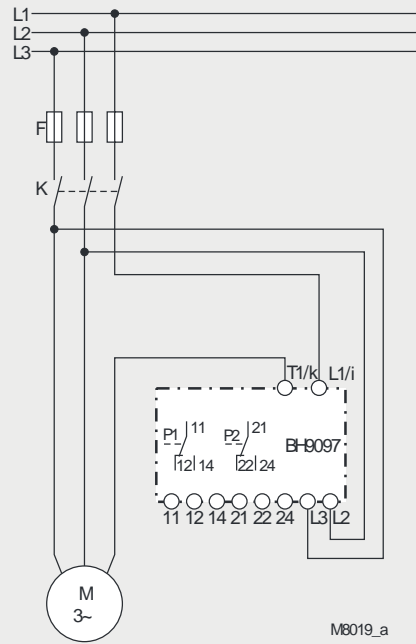

BH 9097.38/001

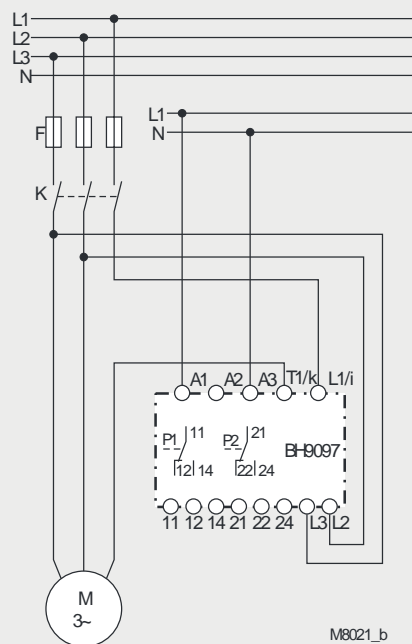

BH 9097.38/011

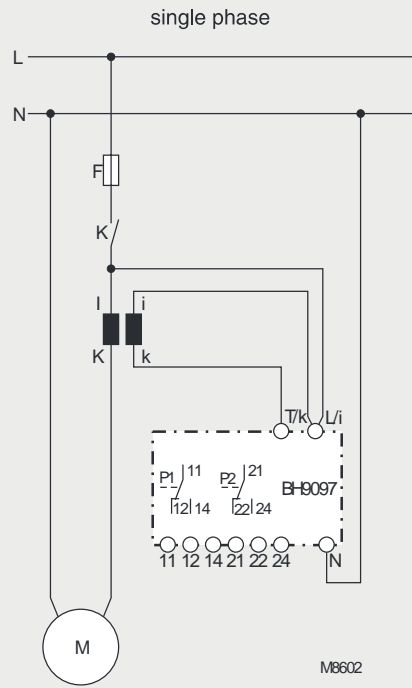

BH 9097.38

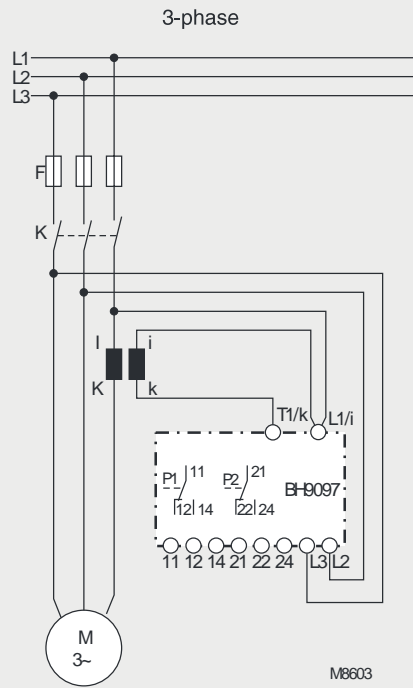

BH 9097.38/001

Note: When using external CTs the adjusted value has to be multiplied with the transmission ratio (\ddot{u}) of the CT.
Example: Switching value = Setting value (P1/P2) \times \ddot{u}

