

VARIMETER

Thermistor Motor Protection Relay
MK 9163N, MK 9163N-ATEX



0245068

MK 9163N

Your advantages

- Reliable temperature monitoring of motors
- Rapid fault location

Features

- According to DIN EN 60947-5-1, DIN EN 60947-8, DIN EN 60079-14, DIN EN 61508, DIN EN 50495, DIN EN 13849
- Monitoring of
 - overtemperature
 - broken wire detection in sensor circuit
 - short circuit detection in sensor circuit
- 1 input for 1 to 6 PTC-resistors
- De-energized on trip
- LED-indicator for
 - auxiliary supply
 - state of contact
- Output with 2 changeover contacts
- As option with manual reset, internal reset button and external remote reset X1/X2
- Wire connection: also 2 x 1.5 mm² stranded ferruled, or 2 x 2.5 mm² solid DIN 46 228-1/-2/-3/-4
- As option with pluggable terminal blocks for easy exchange of devices
 - with screw terminals
 - or with cage clamp terminals
- Width 22.5 mm

Function Diagram

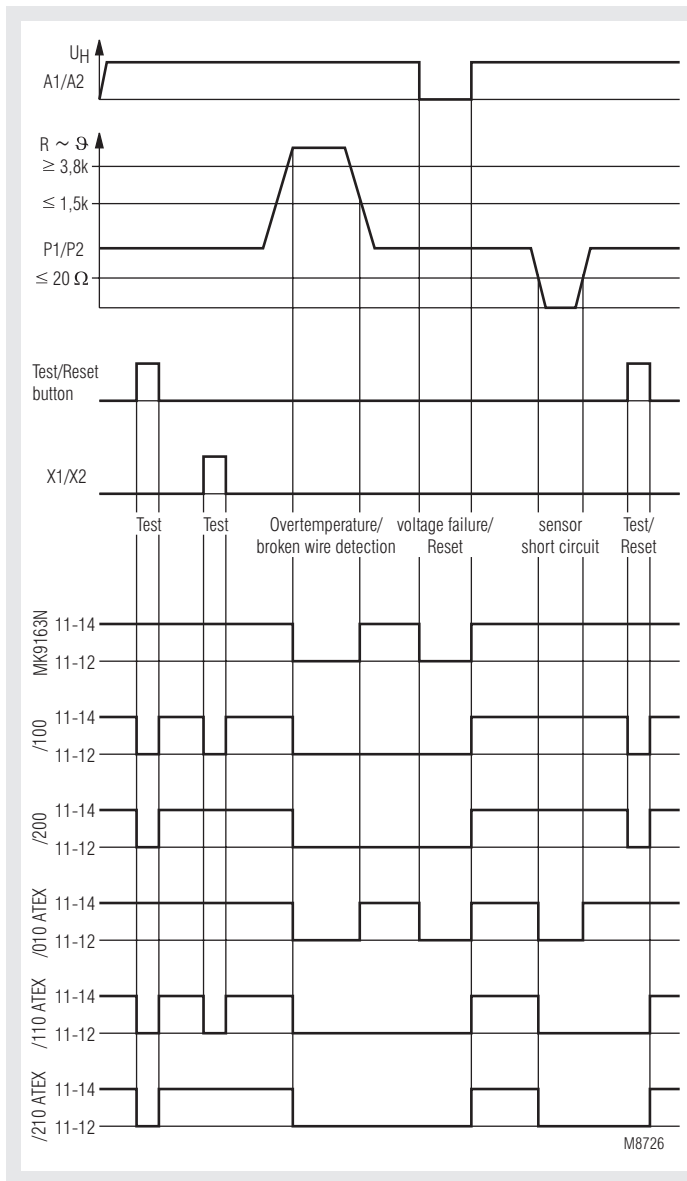

Approvals and Marking



¹⁾ For devices with ATEX-approval

Directive 94/9/EG

EU-Test certificate no.

03 ATEX 3117 II (2) G [Ex e] [Ex d] [Ex px] [Ex n]
II (2) D [Ex tb] [Ex tc]

²⁾ Approval not for all variants; on request

Application

- To protect against thermal overload of motors caused by high switching frequency, heavy duty starting, phase failure on one phase, bad cooling, high ambient temperature
- Temperature monitoring of bearings, transmissions, oil and cooling liquids.

Devices with ATEX-approval:

Temperature monitoring of explosion protected Motors by „extended safety“ EX e DIN EN 60079-7, „pressure proof enclosure“ EX d DIN EN 60079-1 or „overpressure enclosure“ Ex px in gas containing atmosphere as well as „protection by enclosures“ Ex t DIN EN 60079-31 in dust containing atmosphere. The thermistor Motor protection relay protects Standard and Explosion proof Motor against overheating due to overload according to DIN EN 60079-14 and DIN EN 60079-0.

Function

If one of the sensors in the measuring circuit reaches the response temperature (or broken wire is detected), the device indicates failure. This failure is stored in the device with manual reset, even if the temperature goes back to normal. The unit can be reset by pressing the Test/Reset button, by bridging X1/X2 for a short moment or by disconnecting the auxiliary supply for a short time.

Test/Reset button:

Besides the reset function this button provides in normal operation a test facility. The unit indicates fault as long as the button is activated (see also under "Variants").

Circuit Diagrams

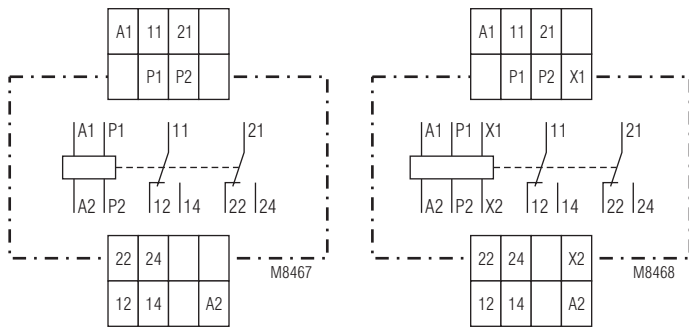

MK 9163N.12,
MK 9163N.12/010-ATEX

MK 9163N.12/100, MK 9163N.12/200,
MK 9163N.12/110-ATEX,
MK 9163N.12/210-ATEX

Indicators

green LED: on, when auxiliary supply connected
red LED: on, when overtemperature or broken wire, short circuit is detected

Technical Data

Input Circuit

Response value: 3.2 ... 3.8 k Ω
Release value: 1.5 ... 1.8 k Ω
Broken wire detection: > 3.8 k Ω
Short circuit on measuring circuit: < 20 Ω
Loading of measuring circuit: < 5 mW (bei R = 1.5 k Ω)
Measuring voltage: \leq 2 V (bei R = 1.5 k Ω)

Auxiliary Circuit

Auxiliary voltage U_H : AC/DC 24 V
AC 110, 230, 400 V 50 / 60 Hz
Voltage range: AC 0.8 ... 1.1 U_H
at 10 % residual ripple: DC 0.9 ... 1.25 U_H
at 48 % residual ripple: DC 0.8 ... 1.1 U_H
Nominal consumption: AC: 1.5 VA
DC: 0.85 W
Nominal frequency: 50 / 60 Hz
Frequency range: 45 ... 65 Hz
Max. bridging time on failure of aux. supply: 20 ms
Operate delay: < 40 ms
Release delay: < 100 ms

External Remote Reset X1/X2

Function: External remote reset X1/X2 with NO contact (voltage free)
Remark: This input is not galvanic separated from measuring input P1/P2

Output

Contacts: MK 9163N, MK 9163N-ATEX: 2 changeover contacts
Thermal current I_{th} : 5 A

Switching capacity MK 9163N

to AC 15
NO contacts: 2 A / AC 230 V IEC/EN 60 947-5-1
NC contacts: 1 A / AC 230 V IEC/EN 60 947-5-1
to DC 13: 1 A / DC 24 V IEC/EN 60 947-5-1

Switching capacity MK 9163N-ATEX

to AC 15: 3 A / AC 230 V IEC/EN 60 947-5-1
to DC 13: 2 A / DC 24 V IEC/EN 60 947-5-1

Electrical life

at 4 A, AC 230 V, $\cos\phi = 0.6$: 1.5×10^6 switching cycles

Short-circuit strength

max. line circuit breaker: C 16 A DIN EN 60 947-5-1

Mechanical life:

$\geq 30 \times 10^6$ switching cycles

Technical Data

General Data

Operating mode: Continuous operation
Temperature range: - 20 ... + 60°C

Clearance and creepage distances

rated impuls voltage / pollution degree: 4 kV / 2 IEC/EN 60 664-1

EMC

Electrostatic discharge: 8 kV (air) IEC/EN 61 000-4-2
HF-irradiation: 10 V / m IEC/EN 61 000-4-3
Fast transients: 4 kV IEC/EN 61 000-4-4

Surge voltages between wires for power supply

at AC 230 V: 2 kV IEC/EN 61 000-4-5
at DC 24 V: 1 kV IEC/EN 61 000-4-5
between wire and ground: 4 kV IEC/EN 61 000-4-5
Interference suppressions: Limit value class B EN 55 011

Degree of protection

Housing: IP 40 IEC/EN 60 529
Terminals: IP 20 IEC/EN 60 529

Housing:

Thermoplastic with V0-behaviour according to UL subject 94

Vibration resistance:

Amplitude 0.2 mm, frequency 10 ... 55 Hz, IEC/EN 60 068-2-6
20 / 060 / 04 IEC/EN 60 068-1

Climate resistance:

20 / 060 / 04 IEC/EN 60 068-1

Terminal designation:

EN 50 005

Wire connection

Screw terminals

(integrated):

1 x 4 mm² solid or
1 x 2.5 mm² stranded ferruled or
2 x 1.5 mm² stranded ferruled or
2 x 2.5 mm² solid

Insulation of wires or sleeve length:

8 mm

Plug in with screw terminals

max. cross section

for connection: 1 x 2.5 mm² solid or
1 x 2.5 mm² stranded ferruled

Insulation of wires or sleeve length:

8 mm

Plug in with cage clamp terminals

max. cross section

for connection: 1 x 4 mm² solid or
1 x 2.5 mm² stranded ferruled

min. cross section

for connection: 0.5 mm²

Insulation of wires or sleeve length:

12 \pm 0.5 mm

Wire fixing:

Plus-minus terminal screws M 3.5
box terminals with wire protection or
cage clamp terminals

max. 0.8 Nm

Fixing torque:

DIN rail IEC/EN 60 715

Weight:

160 g

Dimensions

Width x height x depth

MK 9163N: 22.5 x 90 x 102 mm
MK 9163N PC: 22.5 x 111 x 102 mm
MK 9163N PS: 22.5 x 104 x 102 mm

Technical Data

Safety Related Data

Values according to EN 61508 / EN 50495

SIL:	1 (Typ B)	
T ₁ (Proof Test Intervall):	2	a
HFT:	0	
SFF:	36,6	%
PFD _G :	7,83 x 10 ⁻³	
λ _{du} [FIT]:	894	
λ _{dd} [FIT]:	0	
λ _{su} [FIT]:	516	
λ _{sd} [FIT]:	0	
Mode of operation:	low demand mode	
Architecture:	1001	

Values according to EN 13849:

Category:	1	
PL:	c	
MTBF:	81	a
MTTF _d :	63,8	a
DC _{avg} :	0	%



The a.m. data for functional safety is valid for an ambient temperature of 40°C respecting also selfheating. Data for other ambient temperatures are available on request.

CCC-Data

Thermal current I_{th}: 4 A

Switching capacity

to AC 15:	1,5 A / AC 230 V	IEC/EN 60 947-5-1
to DC 13:	1 A / DC 24 V	IEC/EN 60 947-5-1



Technical data that is not stated in the CCC-Data, can be found in the technical data section.

Standard Type

MK 9163N.12/110-ATEX	AC 230 V	50/60 Hz
Article number:	0056453	
• with Test/Reset button		
• Output:	2 changeover contacts	
• Nominal voltage U _N :	AC 230 V	
• Width:	22.5 mm	

Variants

MK 9163N.12 /	
	ATEX with approval
	0 free
	0 without short circuit detection
	1 with short circuit detection (ATEX)
	0 without RESET
	1 with RESET and test function via built in button and X1/X2
	2 with RESET and test function via built in button, at X1/X2 RESET function only

Available variants

MK 9163N.12
 MK 9163N.12/100
 MK 9163N.12/200
 MK 9163N.12/010 ATEX
 MK 9163N.12/110 ATEX
 MK 9163N.12/210 ATEX

Ordering example for variants

MK 9163N .12 / / ATEX AC/DC 230 V 50/60 Hz

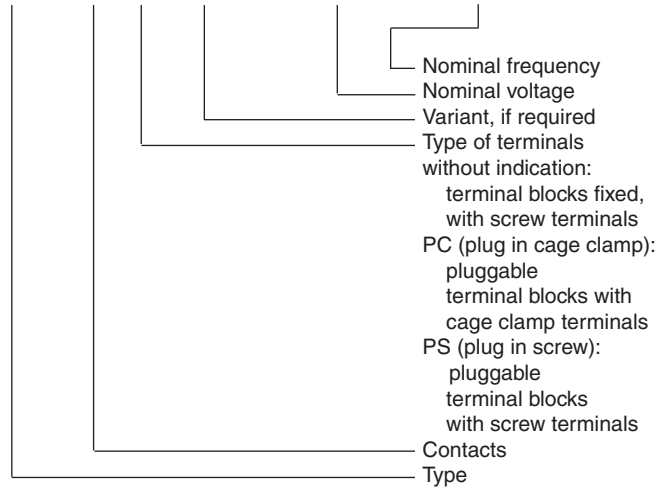

Options with Pluggable Terminal Blocks

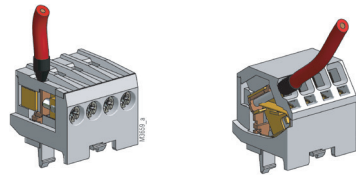

Screw terminal (PS/plugin screw) Cage clamp terminal (PC/plugin cage clamp)

Notes

Removing the terminal blocks with cage clamp terminals

1. The unit has to be disconnected.
2. Insert a screwdriver in the side recess of the front plate.
3. Turn the screwdriver to the right and left.
4. Please note that the terminal blocks have to be mounted on the belonging plug in terminations.

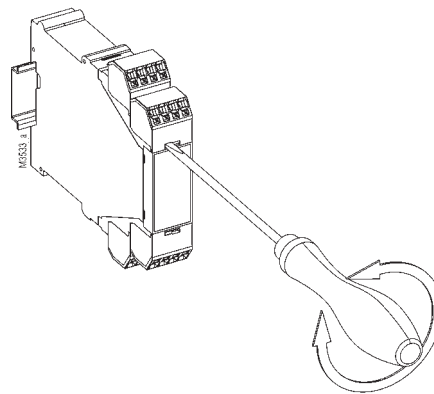

Manufacturing Data

Each unit is marked with the manufacturing date e.g. "Bj. KW 49/02". The unit had been produced in week 49 – 2002.

Additional Remarks and Safety Instructions

Use on motors in explosion hazardous areas

Thermal protection on motors that are equipped with PTC sensors according to DIN 44 081 or DIN 44 082 or DIN EN 60034-11 type A (DIN EN 60947-8). When used on motors of protection degree EX and EX d only the sensor wire leads through the Ex-area. The motor protection relay has to be mounted outside the Ex-area, but monitors devices operated in the Ex-area.

Safety integrity level SIL 1

To fulfil SIL 1 a cyclic function test of the protection device has to be provided. This can be done manually during maintenance (see below).

The function test must be carried out all 2 years.

Test facilities for set-up and maintenance

A test of the unit can be made by simulating the resistance on the sensor input. During maintenance these tests can also be made.

- Test of short circuit detection: Bridge sensor input (this test is possible without disconnection of the sensor).
- Test of broken wire detection: Disconnect sensor wire.
- Test of overtemperature function: Change resistance on input from low 50 ... 1500 Ω to 4 k Ω .

The RESET button can also be used for test purpose (see Function Diagram)

Installation

The DC 24 V version has no galvanic separation between auxiliary supply (A1, A2) and the sensor circuit (P₁, P₂). These units are only allowed to be connected to transformers according to DIN EN 61 558 or to battery supply.

Wiring

The sensor and control wires have to be installed separately from the motor wires. When strong inductive or capacitive influence is expected from parallel installed high current wires, screened wire should be used.

Wire length

The max. wire length of the sensor circuit is:

Diameter (mm ²):	4	2.5	1.5	0.5
max. wire length (m):	2 x 550	2 x 250	2 x 150	2 x 50

Safety instructions

- Installation, test and replacement may only be carried out by qualified specialist staff and the applicable safety rules must be observed. The data for functional safety in explosion hazardous areas have to be respected.
- Details of the motor supplier and the details about the explosion protection from the EC-type examination certificates for explosion proof motors have to be respected.
- For the test and the maintenance of motor protection devices for explosion proof machines, the EN 60079-17 and the safety rules that result from the motor application and the corresponding type of protection have to be respected (EC ATEX Directive 94/9/EC and DIN EN 60079-14).
- The motor protection relay has to switch off the motor immediately also when it is controlled by an inverter. The control circuit must allow this. In this case the sensor wires must be lead separately. The use of wires inside the motor connection cable is not allowed.
- If variants are used that have no no-voltage safe reset function additional measures have to be applied in order to disable safely the restart of the motor until the fault is removed if this leads to a dangerous situation.
- The relay must only be opened by the manufacturer.
- The relay must only be replaced by equivalent devices marked according to the relevant safety rules.
- The permitted ambient conditions must be observed.
- Devices that show obvious transportation damage must not be used in safety relevant applications.

Application Example

