



Level



Pressure



Flow



Temperature



Liquid
Analysis



Registration



Systems
Components



Services



Solutions

Technical Information

Flexdip CYH112

Holder system for water and wastewater assemblies



Application

- Water treatment
- Wastewater treatment
- Plant design

CYH112 is a modular holder system for sensors and assemblies in open basins, channels and tanks.

Sensors installed in assemblies get in this way directly immersed in the medium - the in-situ measurement allows direct and prompt measured values without detour via sampler.

A very flexible holder system is needed to be able to install the assembly at the right point.

The holder system CYH112 works for nearly any type of fixing - fixing on the floor, wall or directly on a rail.

Your benefits

- Simple, cost-effective and flexible expandable
- Modular construction system
- Installation of the holder system on the floor, on the wall, on the rail
- Installation of the sensor on a cantilever arm with chain, fixed immersion pipe or free swinging installation
- Float-lever version for varying levels
- Holder adjustable in height, position and orientation
- Expandable, easy to retrofit
- Stainless steel or plastic version
- Captive screw joints
- Easy to install and to maintain

Function and system design

Measuring system

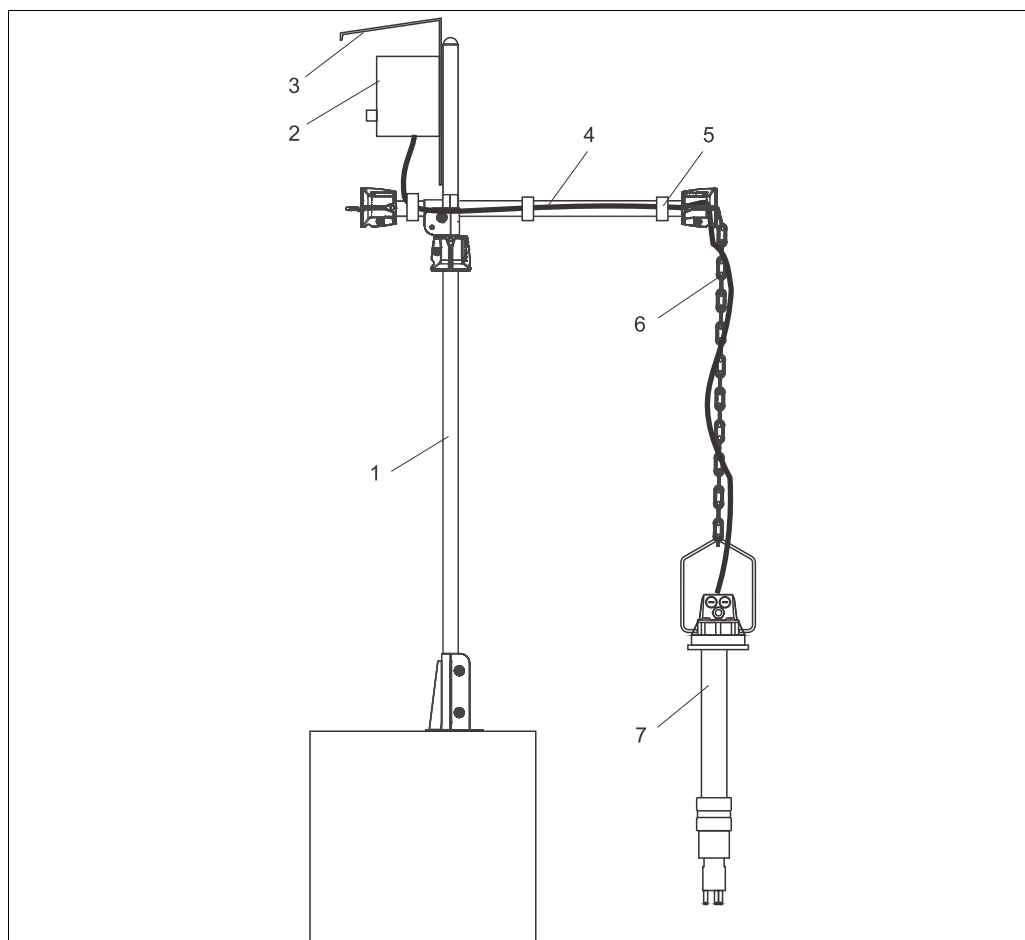

Measuring system (example)

a0010865

- | | | | |
|---|--------------------------------|---|--------------------------|
| 1 | Main pipe with floor mounting | 5 | Hook-and-loop cable ties |
| 2 | Transmitter | 6 | Chain |
| 3 | Weather protection cover | 7 | Assembly |
| 4 | Transverse pipe with fasteners | | |

The version above contains:

- Main pipe (upright post)
- Floor mounting
- Cantilever arm
- Chain mounting of assembly and sensor

The holder system is designed for bringing immersion sensors safely into the process. It is also designed for safe and user-friendly installation of the transmitter and related functional elements. Any combination of the elements among each other are realizable.

The main pipe can be used to install a transmitter with weather protection cover.

The weather protection cover can also be used for installing overvoltage protection and junction box on it. Mounting holes have to be drilled onsite.

The transverse pipe is used to position the sensor regarding distance to the wall and the immersion location. The assembly is used for the adjustment of the immersion depth and for the safe fixing of the sensor in the medium.

Hook-and-loop cable ties (see product structure) are used for cable routing. Cable routing of the power cable has to be done onsite.

Elements

The holder system CYH112 is based on main pipe, transverse pipe and the fastening elements. The flexible construction permits configuration to suit all installation needs.

Main elements

The main elements are:

- Main pipe Ø 40 mm (1.57 ") of the following lengths: 500, 1000 and 1800 mm (19.7, 39.4 and 70.9 ")
- Transverse pipe Ø 40 mm (1.57 ") of the following lengths: 500, 1000 and 1500 mm (19.7, 39.4 and 59 ")
- Chain with a length of 5 m (16.4 ft)

The open ends of the pipes are covered by caps.

The main pipe has no cap at the lower end and must be installed in a way that no water can collect inside.

The chain will be delivered with two multifunctional clamp rings and one triangle carabiner (chain retainer).

Fastening elements

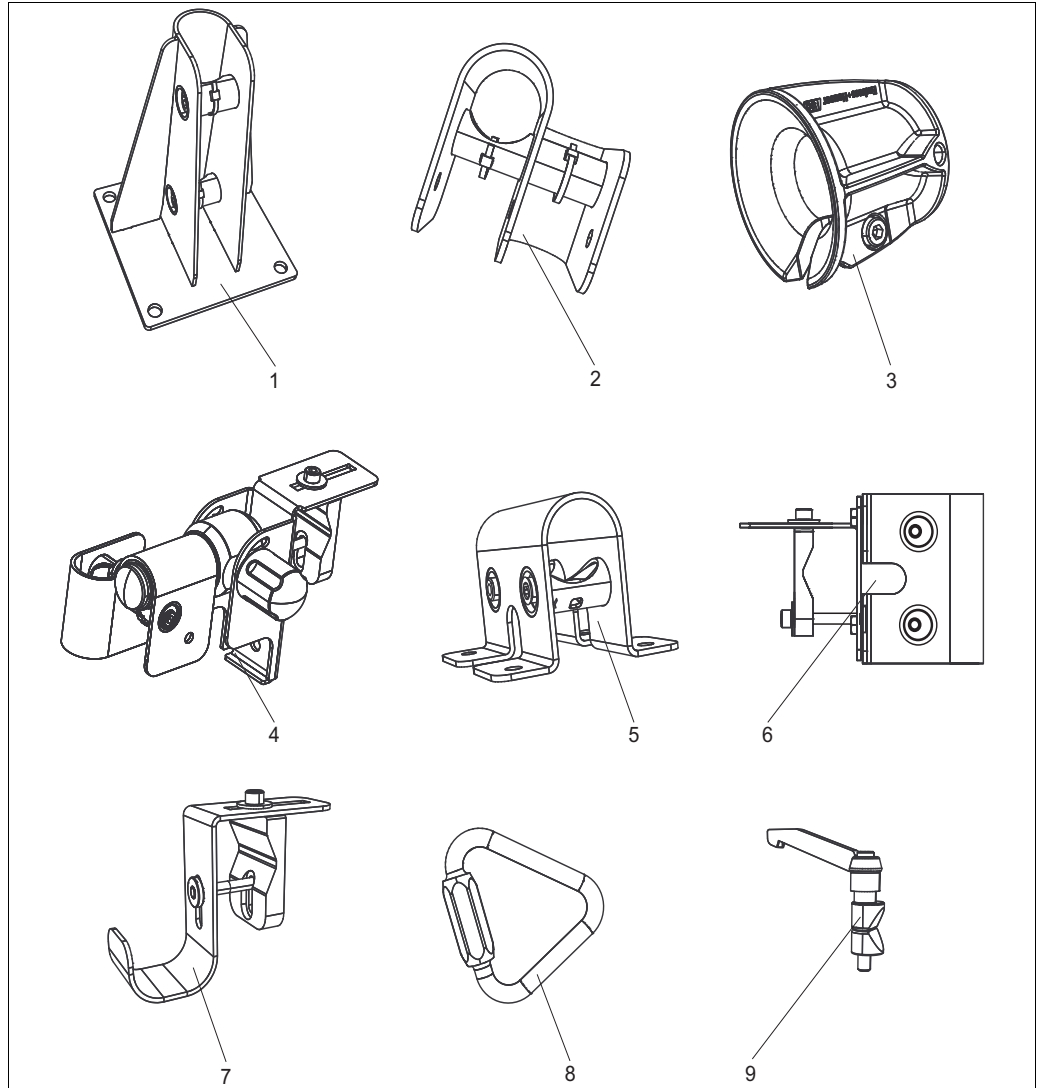

Fastening elements

a0010858

- | | | | |
|---|--------------------------------|---|-------------------------------------|
| 1 | Floor mounting (stand support) | 6 | Rail mounting |
| 2 | Cross clamp | 7 | Immersion pipe support |
| 3 | Multifunctional clamp ring | 8 | Triangle carabiner (chain retainer) |
| 4 | Pendulum holder | 9 | Quick clamp |
| 5 | Wall / flat surface mounting | | |

Functions of the stand support:

- Installation of the main pipe (upright post) on the floor
- Installation of the transverse pipe on the wall

The cross clamp allows the joining of two pipes in the angle of 90°.

Functions of the multifunctional clamp ring:

- At chain systems the multifunctional clamp ring located to the process is used as chain guide.
- At chain systems the multifunctional clamp ring located away from the process is used as chain retainer.
- Working height adjustment of main pipe (version main pipe with transverse pipe).
- Prevention of slip through of the pipes.
- Chain securing in conjunction with the triangle carabiner.

Quick clamp as retrofit kit:

- Convenient operation of the cross clamp and the flat surface mount for quick extending, retracting and turning of the transverse pipe.
- Convenient sensor maintenance with rail mounting

For the rail mounting, the holder system is reduced to a pendulum holder and a cross clamp. This allows pendulum movements in both axes.

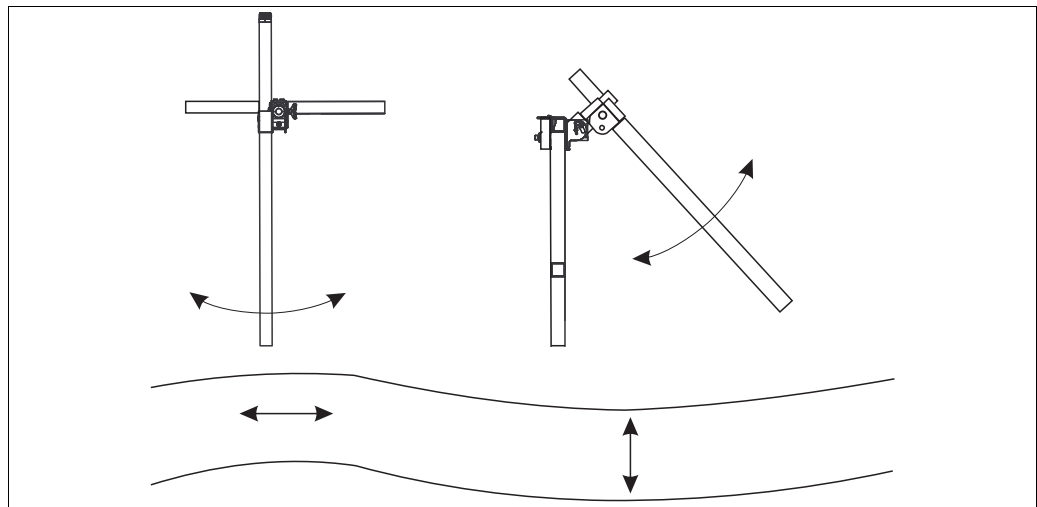

Pendulum movements in both axes

Mounting to wall and flat surface mount are used to install the transverse pipe. After loosening the clamp elements you can position the transverse pipe.

Examples

In the following examples the actual parts of the holder system are highlighted by a grey background.

Upright post for transmitter

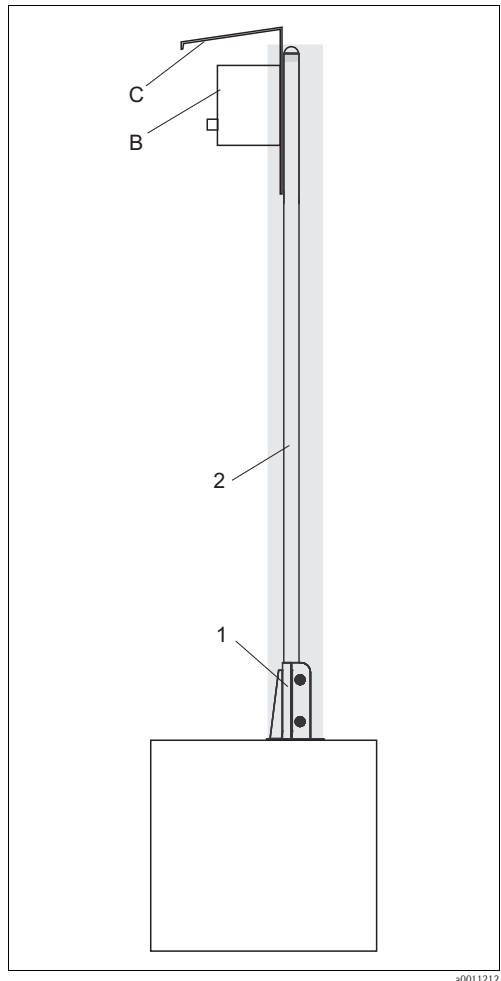

- 1 Floor mounting
- 2 Main pipe 1800 mm (70.9")
- B Transmitter (not included in the scope of delivery)
- C Weather protection cover CYY101 (not included in the scope of delivery)

Order code of the holder system:
CYH112-AB60A11A1

Structure:
Main pipe floor mounting

Main pipe with floor mounting and solid assembly mounting

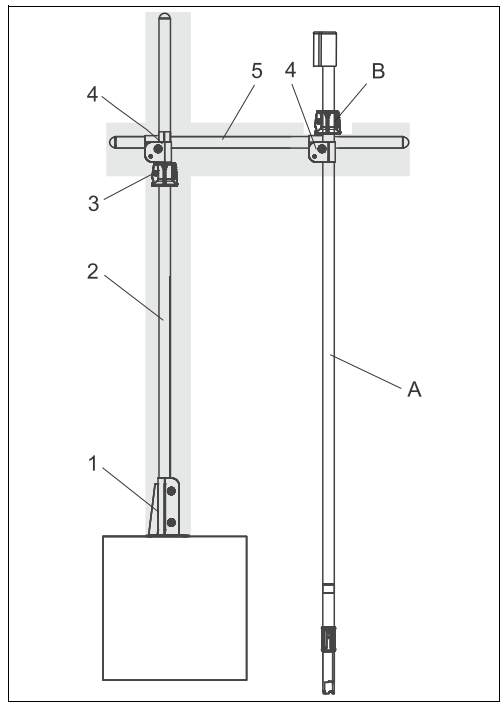

- 1 Floor mounting
- 2 Main pipe 1800 mm (70.9")
- 3 Multifunctional clamp ring
- 4 Cross clamp
- 5 Transverse pipe 1000 mm (39.4")
- A Assembly CYA112 with immersion pipe (not included in the scope of delivery)
- B Additional multifunctional clamp ring (not included in the scope of delivery)

Order code of the holder system:
CYH112-AB60B50D1

Structure:
Main pipe with floor mounting
Transverse pipe
Fixed mounting of the assembly

The multifunctional clamp ring (3) supports the transverse pipe.
The additional multifunctional clamp ring (B) prevents the slip through of the assembly.

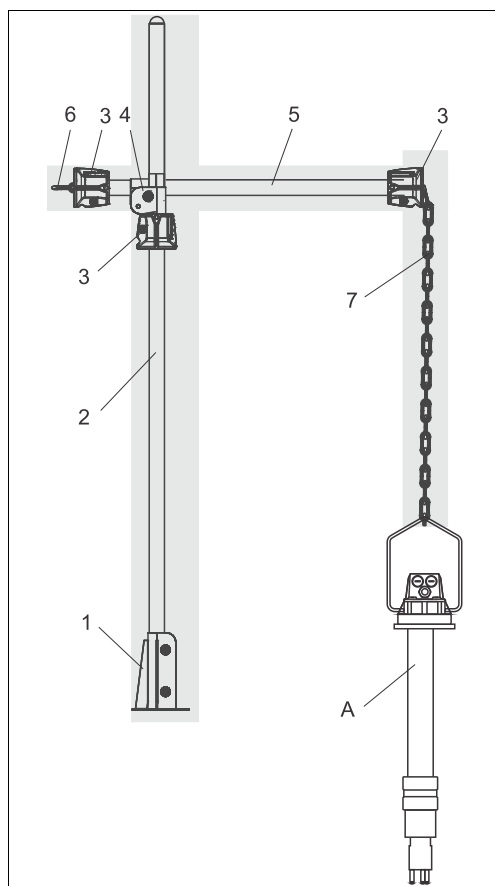
Main pipe with floor mounting and chain holder system

- 1 Floor mounting
- 2 Main pipe 1800 mm (70.9")
- 3 Multifunctional clamp ring
- 4 Cross clamp (holding the transverse pipe)
- 5 Transverse pipe 1000 mm (39.4")
- 6 Triangle carabiner
- 7 Chain
- A CPA111 assembly (not included in the scope of delivery)

Order code of the holder system:
CYH112-AB60B50B1

Structure:
Main pipe with floor mounting
Transverse pipe
Assembly hanging at the chain

The triangle carabiner secures the chain at the end of the pipe. It is used to adjust the immersion depth of the assembly.

a0011045

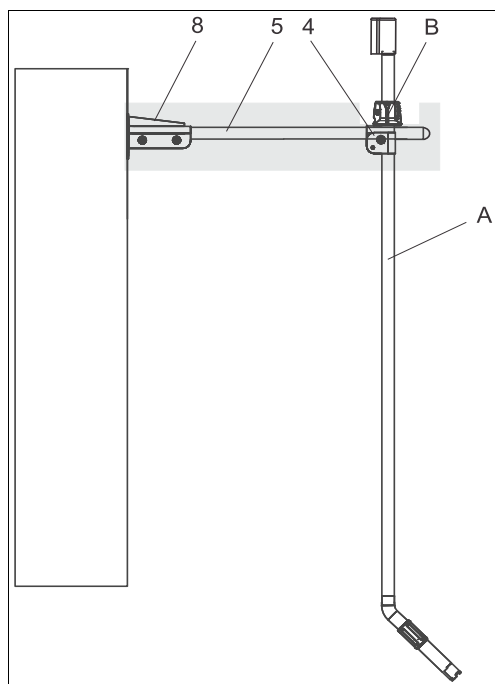
Wall mounting with transverse pipe, solid assembly mounting

- 4 Cross clamp (assembly holder)
- 5 Transverse pipe 500 mm (19.7")
- 8 Wall mounting
- A CYA112 assembly with immersion pipe (not included in the scope of delivery)
- B Additional multifunctional clamp ring (not included in the scope of delivery)

Order code of the holder system:
CYH112-AA11C30D1

Structure:
No main pipe
Transverse pipe with wall mounting
Fixed mounting of the assembly

The additional multifunctional clamp ring (B) prevents the slip through of the assembly.

a0011054

Flat surface mounting with chain holder system

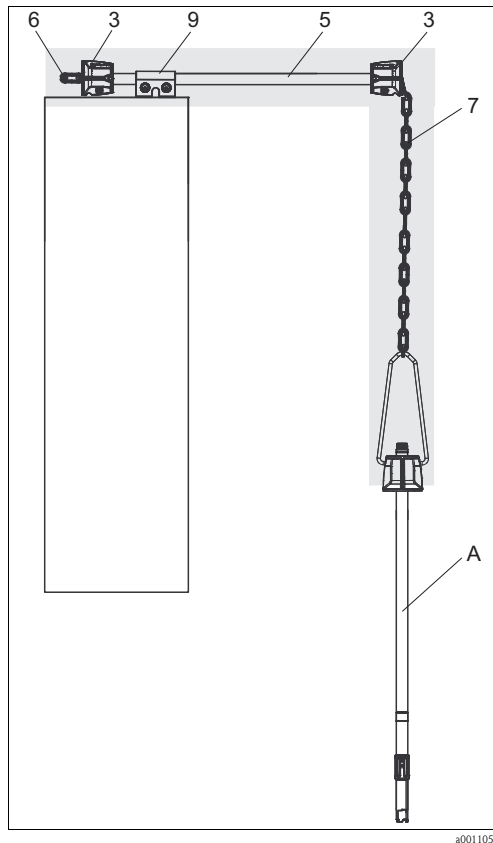

- 3 Multifunctional clamp ring
- 5 Transverse pipe 1000 mm (39.4")
- 6 Triangle carabiner
- 7 Chain
- 9 Flat surface mount
- A CYA112 assembly with chain (not included in the scope of delivery)

Order code of the holder system:
CYH112-AA11D50B1

Structure:
No main pipe
Transverse pipe with flat surface mount
Assembly hanging at the chain

Flat surface mounting with immersion pipe

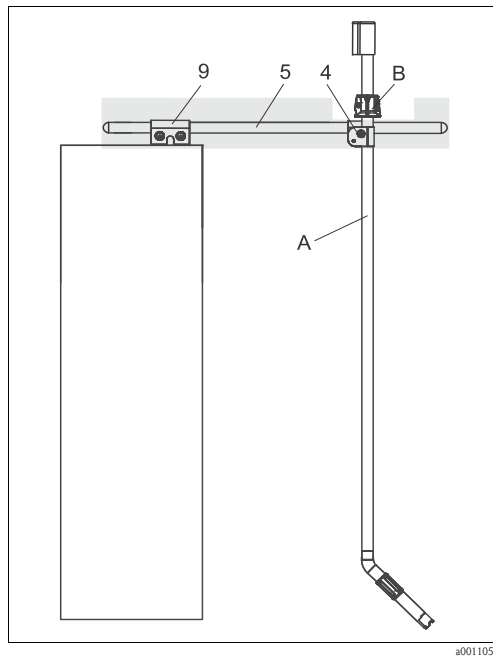

- 4 Cross clamp (assembly holder)
- 5 Transverse pipe 1000 mm (39.4")
- 9 Flat surface mount
- A CYA112 assembly with immersion pipe (not included in the scope of delivery)
- B Additional multifunctional clamp ring (not included in the scope of delivery)

Order code of the holder system:
CYH112-AA11D50D1

Structure:
No main pipe
Transverse pipe with flat surface mount
Fixed mounting of the assembly

The additional multifunctional clamp ring (B) prevents the slip through of the assembly.

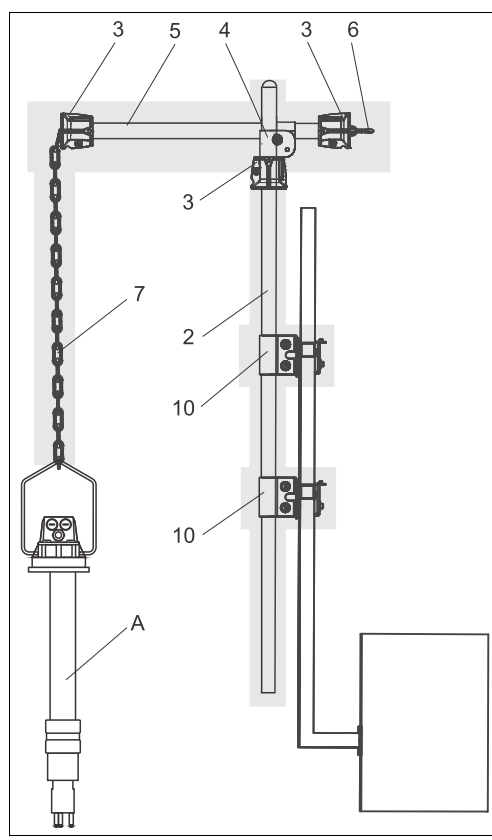
Main pipe with rail mounting and chain holder system

- 2 Main pipe 1800 mm (70.9")
- 3 Multifunctional clamp ring
- 4 Cross clamp (holding the cross pipe)
- 5 Transverse pipe 500 mm (19.7")
- 6 Triangle carabiner
- 7 Chain
- 10 Rail mounting
- A CPA111 assembly (not included in the scope of delivery)

Order code of the holder system:
CYH112-AF60B30B1

Structure:
Main pipe with one or two rail mountings
(depending on load)
Transverse pipe
Assembly hanging at the chain

a0011048

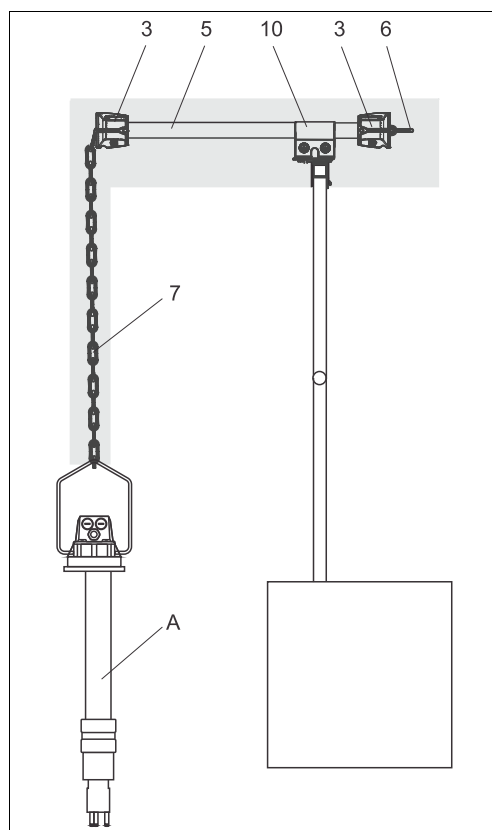
Transverse pipe with rail mounting and chain holder system

- 3 Multifunctional clamp ring
- 5 Transverse pipe 500 mm (19.7")
- 6 Triangle carabiner
- 7 Chain
- 10 Rail mounting
- A CPA111 assembly (not included in the scope of delivery)

Order code of the holder system:
CYH112-AA11E30B1

Structure:
No main pipe
Transverse pipe with rail mounting
Assembly hanging at the chain

a0010256

Transverse pipe with rail mounting and immersion pipe

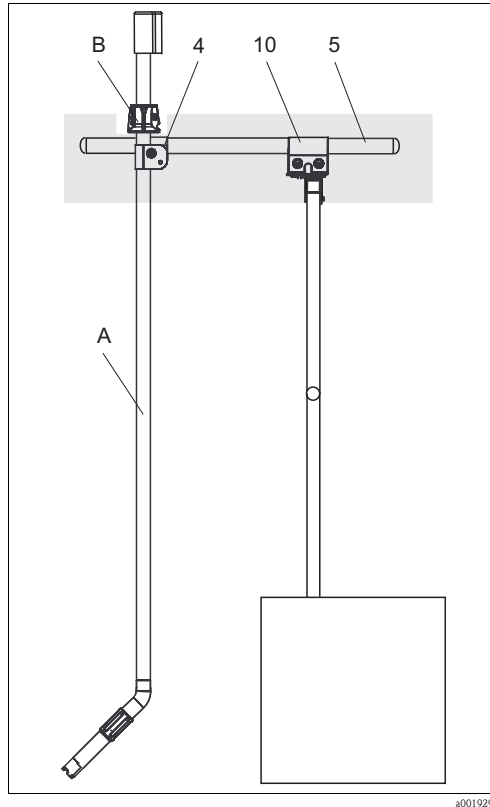

- 4 Cross clamp (holding the cross pipe)
- 5 Transverse pipe 500 mm (19.7")
- 10 Rail mounting
- A CYA112 assembly with immersion pipe (not included in the scope of delivery)
- B Additional multifunctional clamp ring (not included in the scope of delivery)

Order code of the holder system:
CYH112-AA11E30D1

Structure:
No main pipe
Transverse pipe with rail mounting
Fixed mounting of the assembly

Rail mounting (round pipe) with angled position off immersion pipe in water

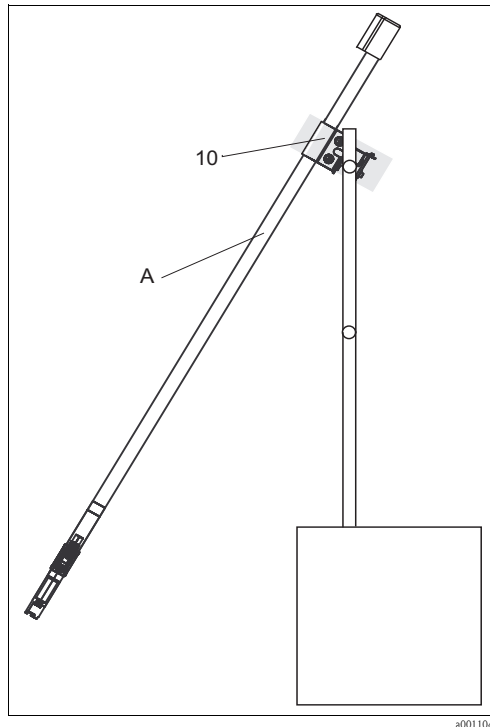

- 10 Rail mounting (round pipe), angled mounting
- A CYA112 assembly with immersion pipe (not included in the scope of delivery)

Order code of the holder system:
CYH112-AE11A11A1

Structure:
No main pipe
No transverse pipe
Angled mounting of assembly at the rail

To maintain the equipment dismount the rail mounting.

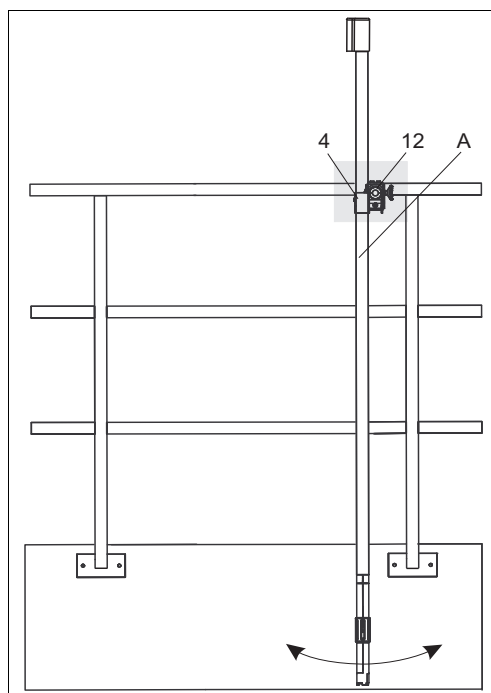
Pendulum holder with immersion pipe mounted at rail

a0011047

- 4 Cross clamp (holding the assembly)
- 12 Pendulum holder
- A CYA112 assembly with immersion pipe (not included in the scope of delivery)

Order code of the holder system:
CYH112-AA11A11E1

Structure:

No main pipe
No transverse pipe
Rail mounting of the assembly via pendulum holder

The assembly can perform pendular movements in the shown direction. For this case, the cross clamp is mounted at the pendulum holder but not fixed.

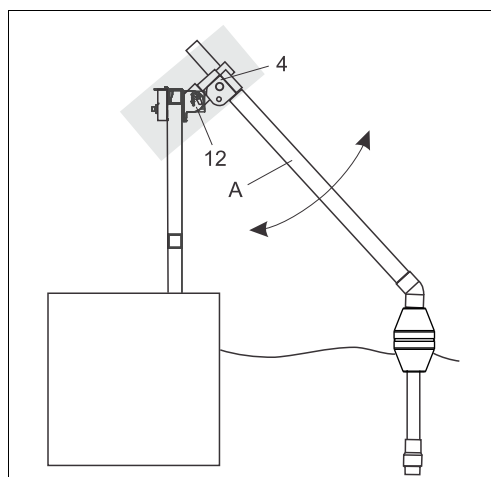
Rail mounting with immersion pipe and floater

a0011051

- 4 Cross clamp (holding the assembly)
- 12 Pendulum holder
- A CYA112 assembly with immersion pipe and floater (not included in the scope of delivery)

Order code of the holder system:
CYH112-AA11A11E1

Structure:

No main pipe
No transverse pipe
Rail mounting of the assembly via pendulum holder

The pendulum holder and the floater allow the assembly to follow the water level.

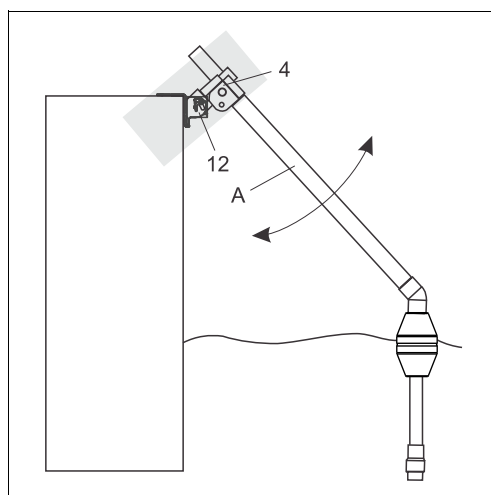
Flat surface mounting with immersion pipe and floater

a0011213

- 4 Cross clamp (holding the assembly)
- 12 Pendulum holder
- A CYA112 assembly with immersion pipe and floater (not included in the scope of delivery)

Order code of the holder system:
CYH112-AA11A11E1

Structure:

No main pipe
No transverse pipe
Flat surface mounting of the assembly via pendulum holder

The pendulum holder and the floater allow the assembly to follow the water level.

Adding a second measuring point to an existing installation:

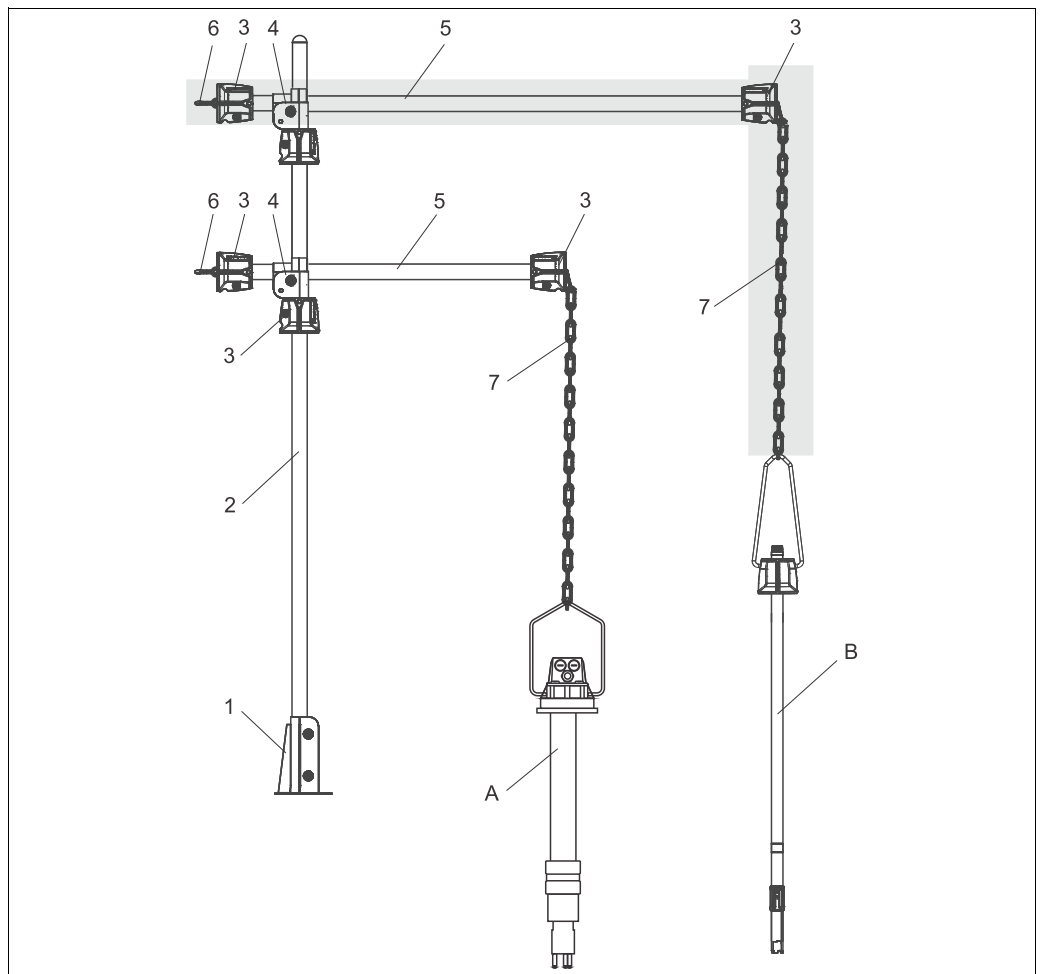

Second transverse pipe with assembly hanging at a chain

a0011251

- | | | | |
|---|----------------------------|---|---|
| 1 | Floor mounting | 6 | Triangle carabiner |
| 2 | Main pipe 1800 mm (70.9") | 7 | Chain |
| 3 | Multifunctional clamp ring | A | CPA111 assembly (not included in the scope of delivery) |
| 4 | Cross clamp | B | CYA112 assembly (not included in the scope of delivery) |
| 5 | Transverse pipe | | |

Order code of the expansion: CYH112-AA11B50B1

Repurchase of components

- Order functional elements via product structure.
- Order the other elements via order code (see chapter "Accessories")

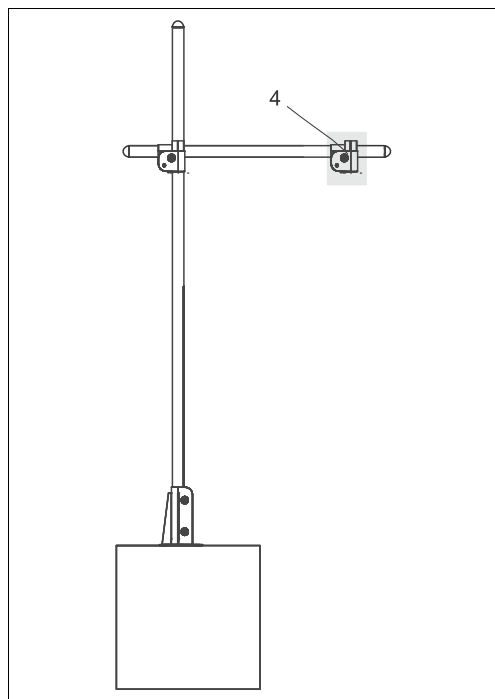

- 4 Cross clamp
For mounting an additional immersion pipe

Order code for a single cross clamp:
CYH112-AA11B11A1

Installation

Installation instructions

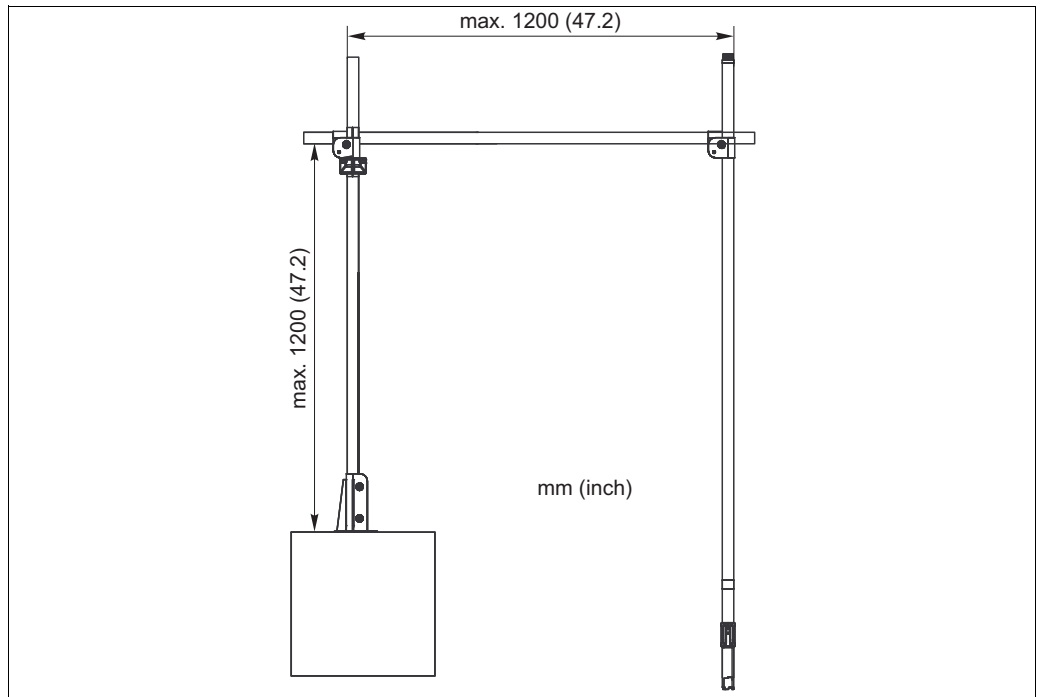

Maximum extension

The given values are valid for floor, wall and rail mounting.
 The maximum extension depends on the load (weight of immersion pipe, assembly and cable). See the following diagram:

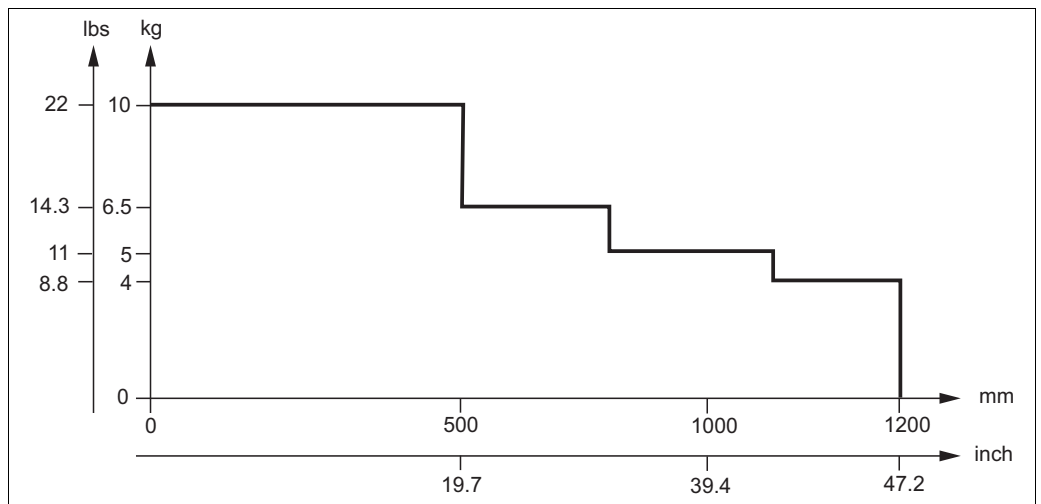

Extension over load

The maximum load for rail mounting and pendulum adapter is 5 kg (11 lbs).

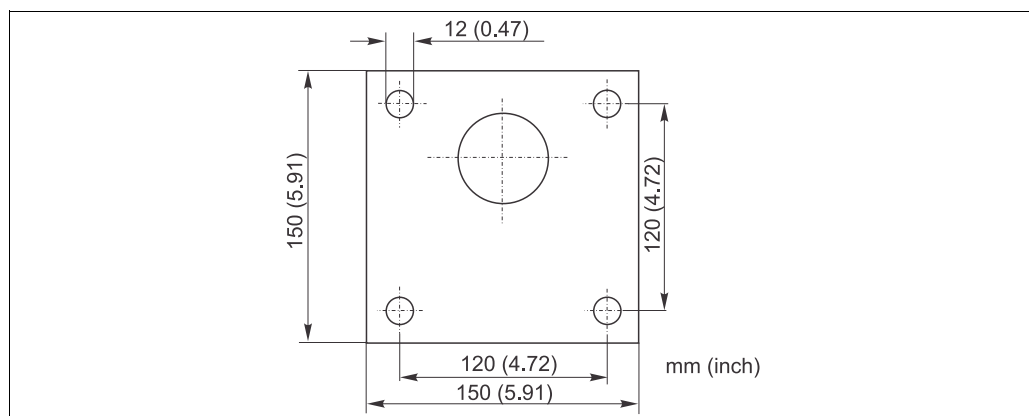
Base plate*Base plate*

a0010790

The minimum distance between bore holes and edge of the basin is 40 mm (1.57 ")

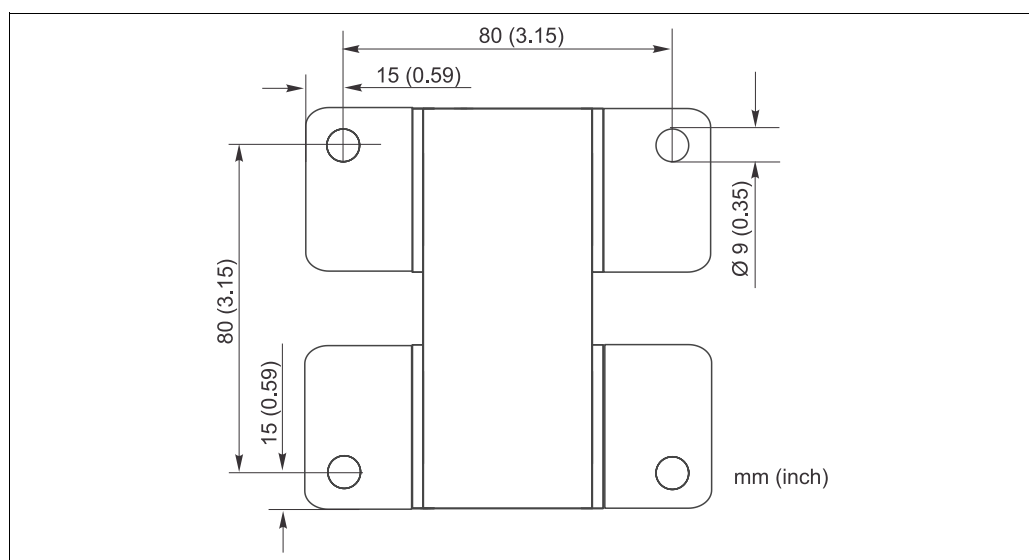
Wall and flat-surface mounting*Drilling distances for wall mounting*

a0010885

Pendulum adapter (flat surface mounting)

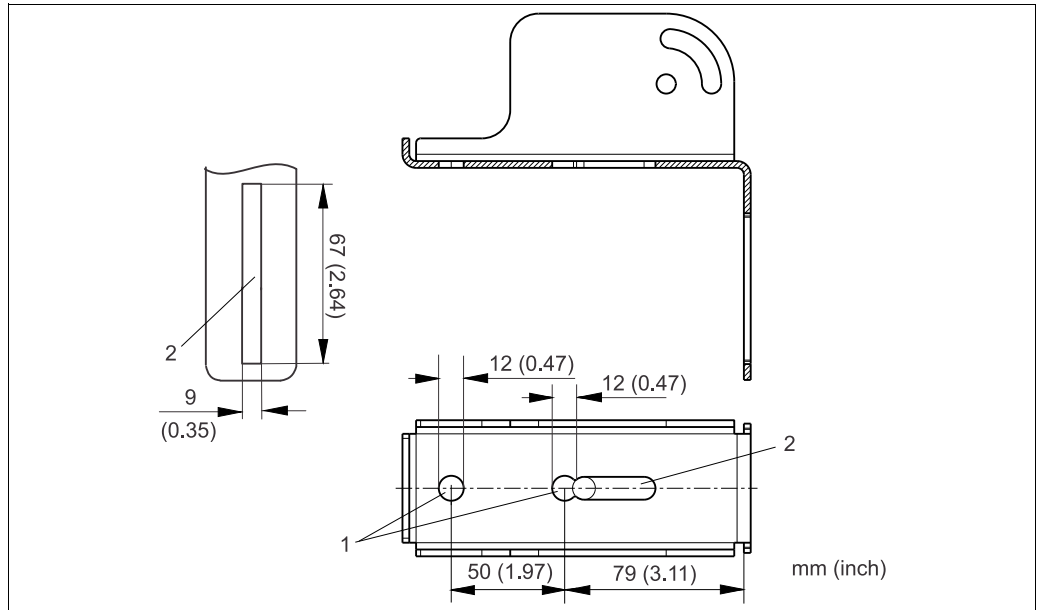

Drilling distances for pendulum adapter (flat surface mounting)

- 1 Mounting holes
- 2 Guide slot

Rail mounting

Cross section of hand rail	rectangular or round
Edge length or diameter	30 to 60 mm (1.18 to 2.36 ")
Alignment for round hand rail	arbitrary
Alignment for rectangular hand rail	vertical or horizontal

Grounding

The grounding has to be done on-site. All conductive parts have to be connected to each other. When using the pendulum holder an electrical connection between transverse pipe or rail and assembly holder (cross clamp) has to be done on-site.

Cable routing

The sensor cable has to be routed outside along the pipe. Hook-and-loop cable ties for fixing the sensor cable are available as accessories. The cable routing of the power cable has to be done on-site.

Environment

Ambient temperature -20 to +60 °C (-4 to 140 °F)

Mechanical construction

Dimensions

Main pipe:	$\varnothing 40 \text{ mm} \pm 0.3 \text{ mm} (1.57'' \pm 0.012'')$, length: 500, 1000 and 1800 mm (19.7", 39.4" and 70.9") wall thickness: $1.5 \text{ mm} \pm 0.15 \text{ mm} (0.06'' \pm 0.006'')$
Transverse pipe:	$\varnothing 40 \text{ mm} \pm 0.3 \text{ mm} (1.57'' \pm 0.012'')$, length: 500, 1000 and 1500 mm (19.7", 39.4" and 59") wall thickness: $1.5 \text{ mm} \pm 0.15 \text{ mm} (0.06'' \pm 0.006'')$
Chain:	5 m (16.4")

Floor mounting

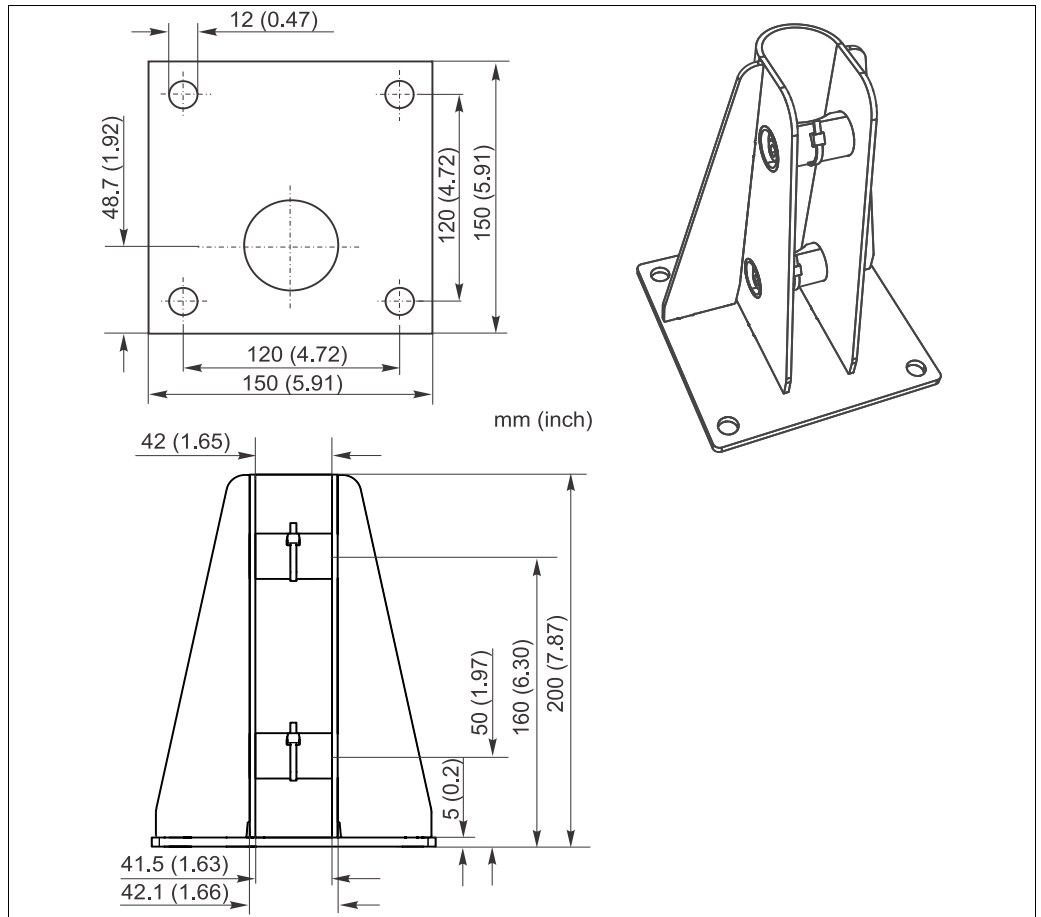

Dimensions floor mounting

Wall and flat surface mounting

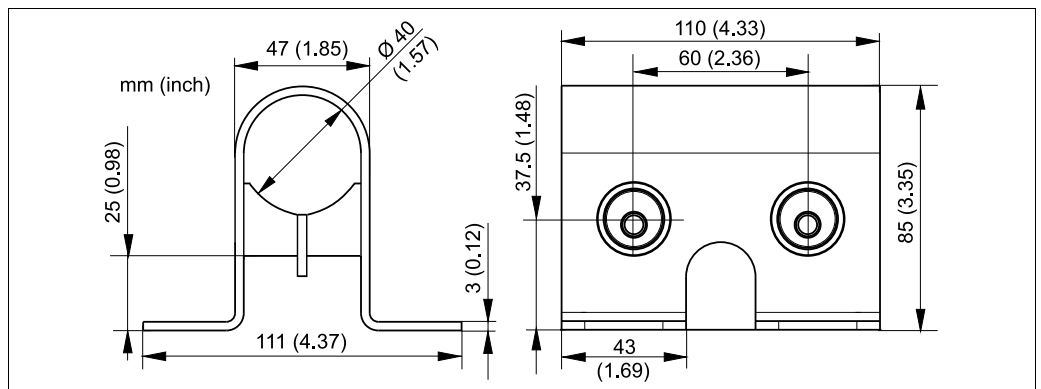

Dimensions of wall and flat-surface mounting

Pendulum holder

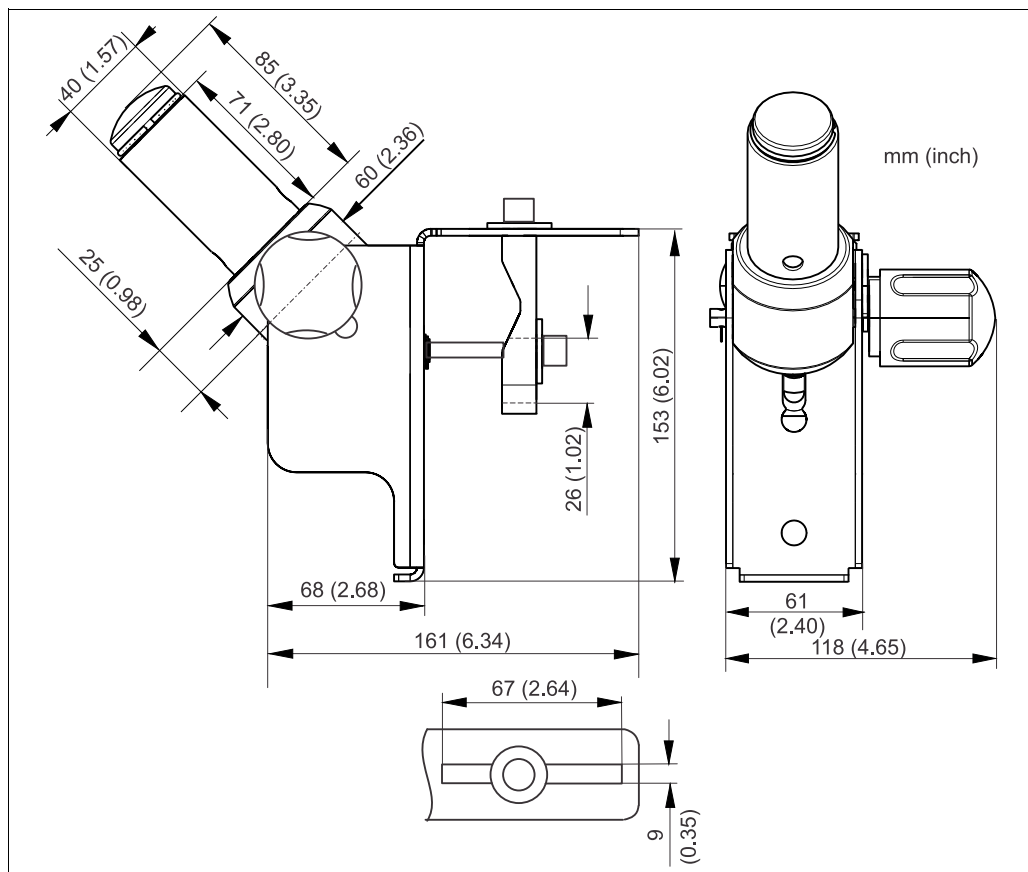

Dimensions of pendulum holder (without cross clamp)

Rail mounting

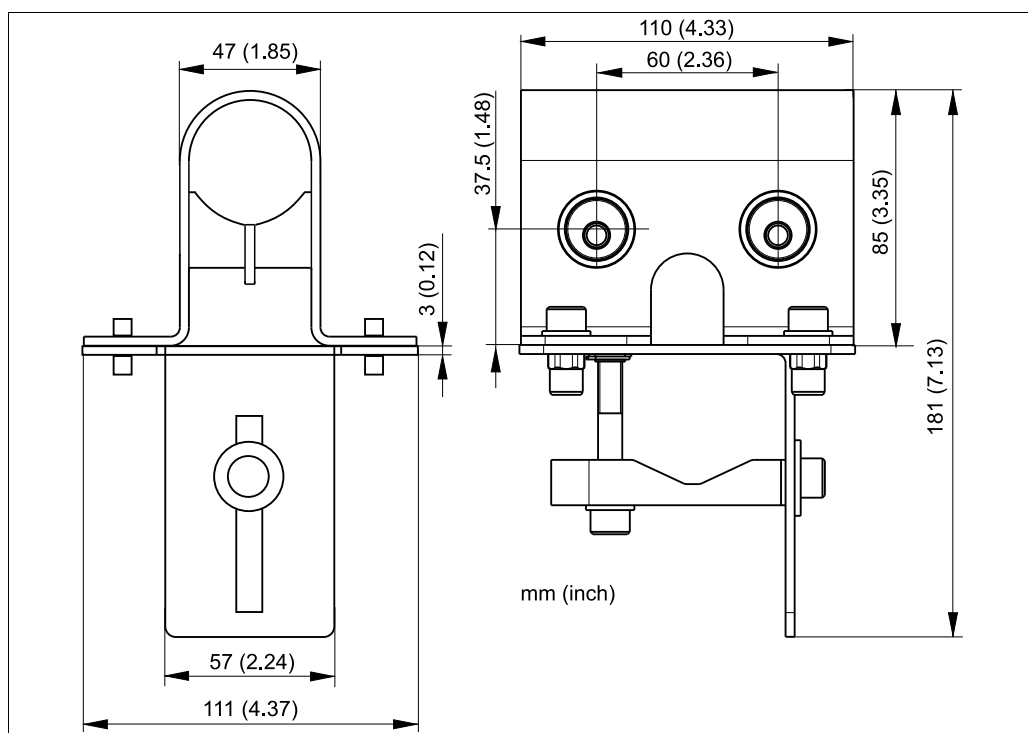

Dimensions of rail mounting

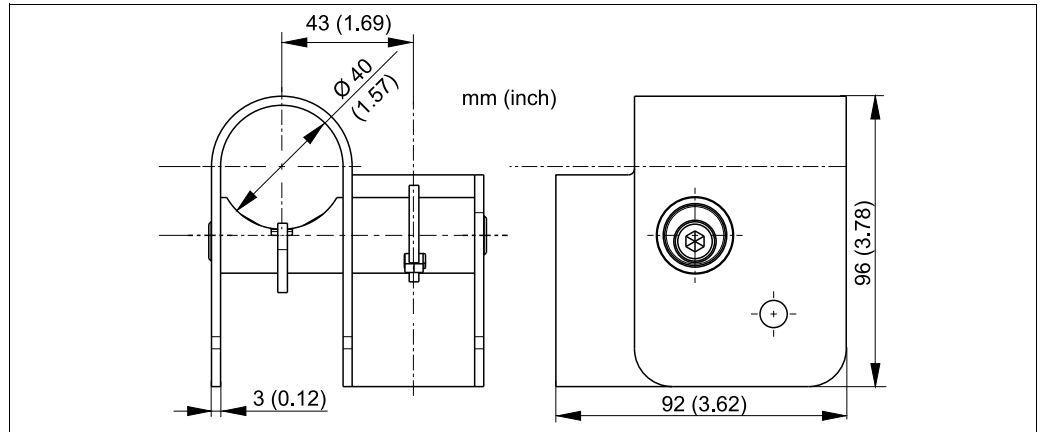
Cross clamp

Dimensions of cross clamp

Weight

Main pipe (length 1 / 2 / 3):	0.7/ 1.5/ 2.6 kg (1.5 / 3.3 / 5.7 lbs)
Transverse pipe (length 1 / 2 / 3):	0.7/ 1.5/ 2.2 kg (1.5 / 3.3 / 4.9 lbs)
Wall mounting:	0.7 kg (1.5 lbs)
Cross clamp:	0.7 kg (1.5 lbs)
Floor mounting:	1.75 kg (3.86 lbs)
Pendulum adapter:	1.1 kg (2.4 lbs)
Chain (plastic):	0.7 kg (1.5 lbs)
Chain (stainless steel):	2.15 kg (4.7 lbs)
Multifunctional clamp ring:	0.15 kg (0.33 lbs)

Materials

Main pipe:	stainless steel 1.4404 (AISI 316L)
Transverse pipe:	stainless steel 1.4404 (AISI 316L)
Wall mounting:	stainless steel 1.4404 (AISI 316L)*
Cross clamp:	stainless steel 1.4404 (AISI 316L)*
Floor mounting:	stainless steel 1.4404 (AISI 316L)*
Pendulum adapter:	stainless steel 1.4404 (AISI 316L)* / POM / thermoplastic
Chain (plastic):	PA (polyamide) UV resistant, tension tested
Chain (stainless steel):	stainless steel 1.4401 (AISI 316)
Multifunctional clamp ring:	POM - GF
Cap:	PE
Quick-clamp handle:	PA

* Wall mounting, cross clamp and floor mounting are made of the described material with the following exceptions: The clamping stones are made of stainless steel 1.4301 (AISI 304). Also the clamping stones and the axle of the pendulum holder are made of stainless steel 1.4301 (AISI 304).

Assemblies

The holder system is designed for the following assemblies:

- Flexdip CYA112
- Dipfit W CLA111
- Dipfit W CPA111
- Existing assemblies like chain assemblies or assemblies with fixed immersion pipe meeting the requirements of the holder system CYH112 (weight, dimensions etc.)

Certificates and approvals

Explosion protection

The CYH112 holder system is suitable for use in hazardous zones 1 and 2.

The ATEX directive 94/9/EC does not apply because the holder system has no potential ignition source.

Accordingly, it is not designated according to ATEX. Potential equalization must be implemented as described in the chapter "Installation conditions".

Ordering information

Scope of delivery

The scope of delivery comprises:

- Ordered assembly holder system
- Operating Instructions, English.

Order information

You have to specify an order code for each measuring point.

Select the system elements as follows:

1. **Mounting of main pipe**
Select the type of mounting.
If you do not need a main pipe, select "w/o".
2. **Main pipe, vertical**
Select height of main pipe.
If you do not need a main pipe, select "w/o".
3. **Mounting of transverse pipe**
Select the type of mounting.
If you do not need a transverse pipe, select "w/o".
4. **Transverse pipe, horizontal**
Select height of transverse pipe.
If you do not need a transverse pipe, select "w/o".
5. **Connection immersion pipe**
Select the needed connection element

If the main pipe shall be equipped with a second measuring point you have to specify a second order code. This also applies for later upgrade.

Order the accessories as follows:

- If you want to order accessories together with the holder system, use the product structure.
- If you want to order accessories only, use the order numbers in the chapter "Accessories".

Order code

You can create a complete and valid order code on the Internet using the configurator tool.

Enter the following address in your browser to access the product page:

www.products.endress.com/cyh112

1. You can choose from the following options on the product page located on the right:

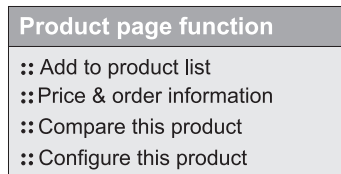

2. Click "Configure this product".
3. The configurator opens in a separate window. You can now configure your device and receive the complete order code that applies for the device.
4. Afterwards, export the order code as a PDF or Excel file. To do so, click the appropriate button at the top of the page.

Product structure

i The following product structure represents the status of printing. You can create a complete and valid order code on the Internet using the configurator tool.

Approvals	
A	w/o
Mounting of main pipe	
A	w/o
B	Mounting to floor
C	Mounting to wall (1x)
D	Mounting to wall (2x)
E	Mounting to rail (1x)
F	Mounting to rail (2x)
Main pipe (vertical 40 mm)	
11	w/o
20	500 mm (19,7 ")
40	1000 mm (39,4 ")
60	1800 mm (70,9 ")
Mounting of transverse pipe	
A	w/o
B	Cross clamp
C	Mounting to wall
D	Flat surface mount
E	Mounting to rail (1x)
Transverse pipe (horizontal 40 mm)	
11	w/o
30	500 mm (19,7 ")
50	1000 mm (39,4 ")
70	1500 mm (59 ")
Connection immersion pipe	
A	w/o
B	Chain, plastic
C	Chain, stainless steel
D	Cross clamp
E	Pendulum holder (rail)
F	Pendulum holder (flat surface mount)
Adapter	
1	w/o
CYH112-	basic order code

The following options are available:

Option code	Description
KA	Multifunctional clamp ring
KB	Quick clamp
KC	Immersion pipe tray
KE	Hook-and-loop cable ties (4 pcs.)
KF	Triangle carabiner (chain clip)
KG	Allen key
KH	Pipe protection cap

Example:

Main pipe: Mounting to floor, 1800 mm (70.9")

Transverse pipe: Mounting with cross clamp, 1000 mm (39.4")

Connection immersion pipe: Cross clamp

Accessories: 1 multifunctional clamp ring, 1 quick clamp

Order code: CYH112-AB60B50D1 KA KB

Accessories

Multifunctional clamp ring

- Chain retainer in conjunction with the triangle carabiner
- Working height adjustment of the main pipe (version main pipe with transverse pipe)
- The multifunctional clamp ring acts as an anti-slip lock on transverse pipes, main pipes and assemblies.
- Material: POM - GF
- Order No. 71092049

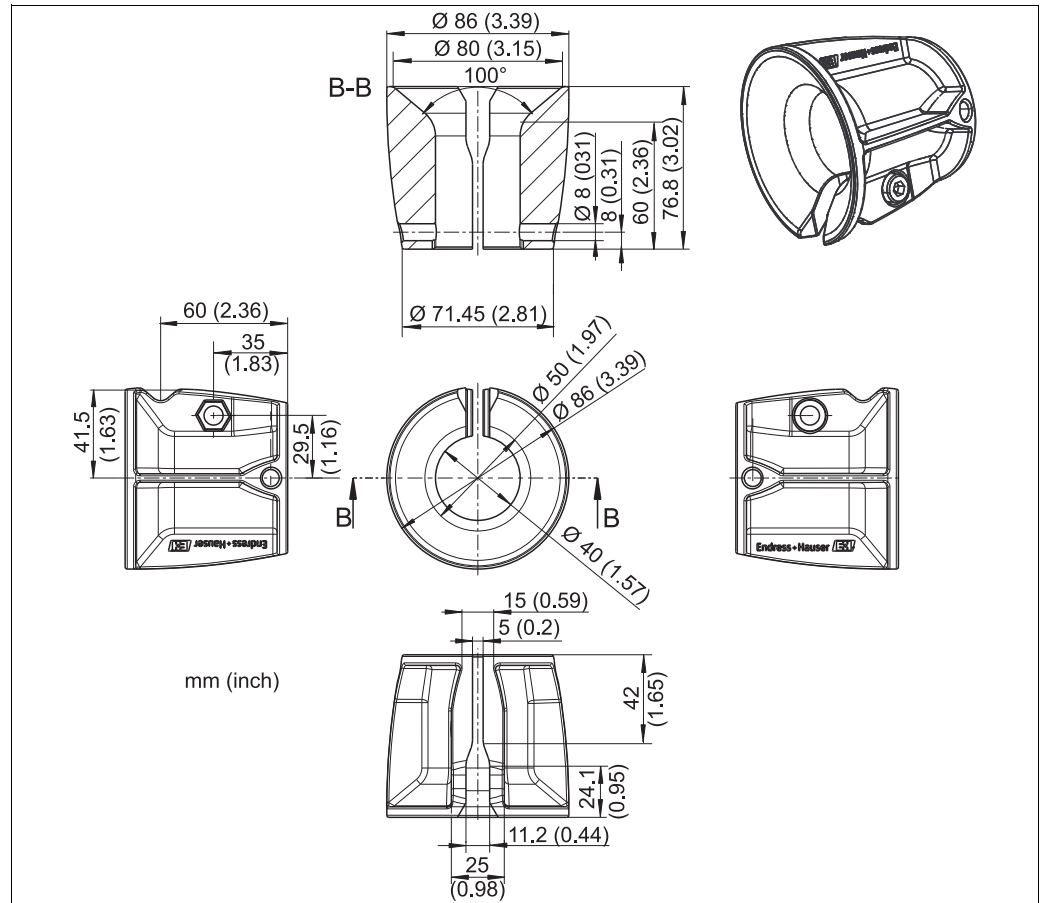

Multifunctional clamp ring

40016879

Immersion pipe support

- Immersion pipe support for comfortable maintenance
- Material: stainless steel 1.4404 (AISI 316L)
- Order No. 71092054

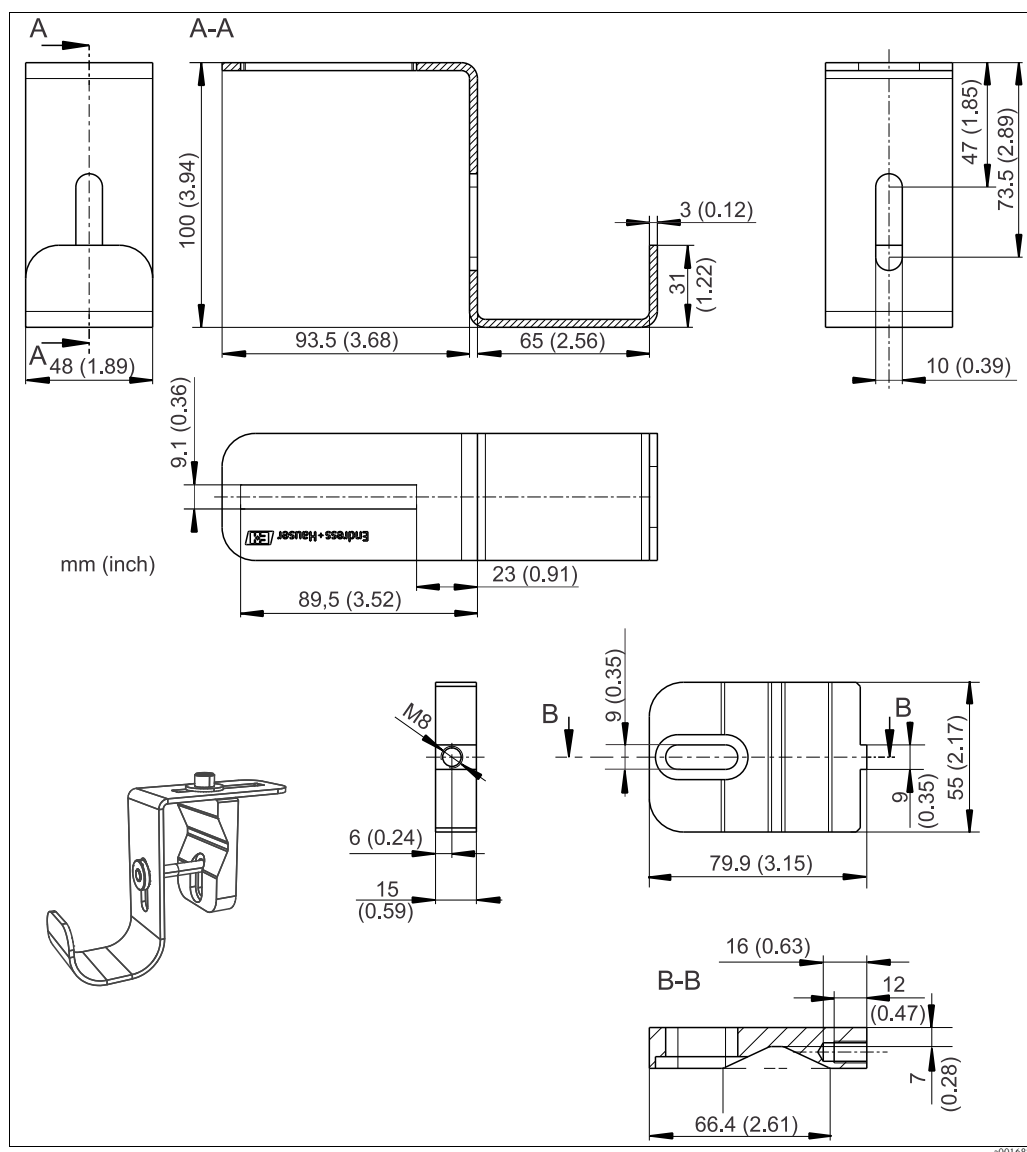

Immersion pipe support

Quick clamp (set of 2 pieces)

- Replaces bolted connection
- Material: stainless steel 1.4301 (AISI 304)
- Order No. 71092050

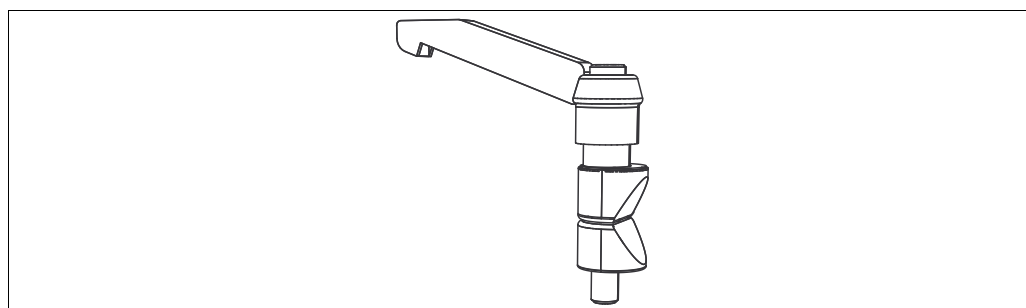

Quick clamp

Triangle carabiner

- Used to fix the chain (together with multifunctional clamp ring)
- Material: stainless steel
- Order No. 71092052

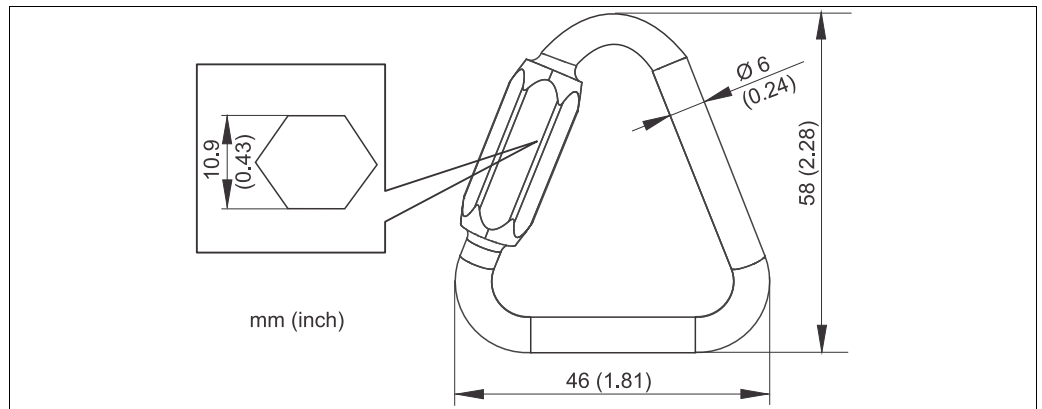

Triangle carabiner

Hook-and-loop cable ties (set of 4 pieces)

- To fix the cables
- Material: PE / PA (polyethylene / polyamide)
- Order No. 71092051

Allen key

- Size: 6 mm
- Order No. 71092057

Pipe protection cap

- Material: PE (polyethylene)
- Order No. 71092053

CYY101 weather protection cover for field devices, absolutely essential if operating the unit outdoors

- Material: stainless steel 1.4031 (AISI 304)
- Order No. CYY101-A

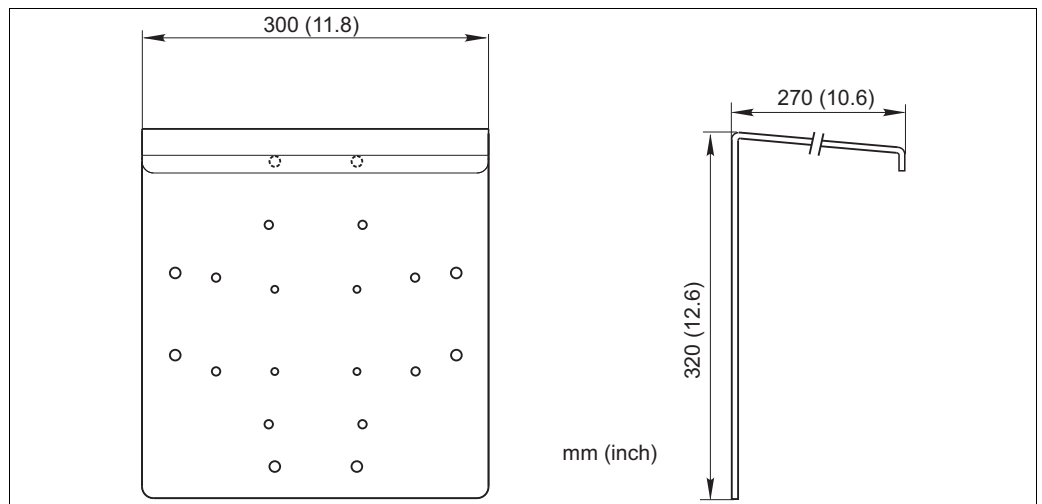

Weather protection cover for field devices

- Round post fixture to fix the stainless steel weather protection cover CYY101 to vertical or horizontal posts with diameters of up to 70 mm (2.76");
Order no. 50062121

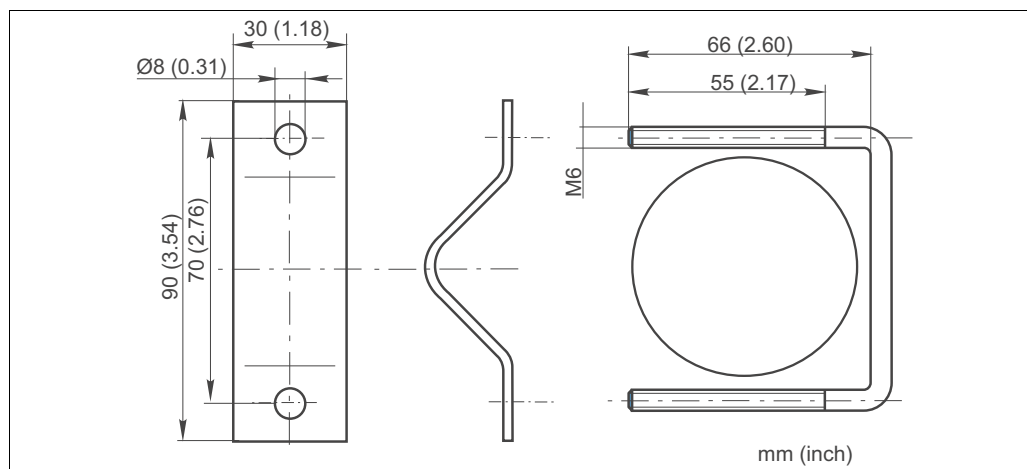

Round post fixture for CYY101

Overvoltage protection

- Overvoltage protection HAW56X
- Plus additional installation material

Instruments International

Endress+Hauser
Instruments International AG
Kaegenstrasse 2
4153 Reinach
Switzerland

Tel.+41 61 715 81 00
Fax+41 61 715 25 00
www.endress.com
info@ii.endress.com

Endress+Hauser 
People for Process Automation