



Level



Pressure



Flow



Temperature

Liquid
Analysis

Registration

Systems
Components

Services



Solutions

Technical Information

Liquiphant M FTL51C

Vibronic

Point level switch for all kinds of liquids
with high corrosion-resistant coating



Application

The Liquiphant M is a point level switch which can be used in all liquids

- for temperatures from -50 °C to 150 °C
(up to 230 °C on request)
- for pressures up to 40 bar
- for viscosity up to $10,000\text{ mm}^2/\text{s}$
- for densities $\geq 0.5\text{ g/cm}^3$ or $\geq 0.7\text{ g/cm}^3$,
other settings available on request
- foam detection on request

The reliable function is not affected by flow, turbulence, bubbles, foam, vibration, solids content or buildup. The Liquiphant is thus the ideal substitute for float switches.

All the wetted parts of the sensor (process connection, extension pipe and tuning fork) are coated in enamel or various synthetic materials, making the point level switch suitable for applications in very aggressive liquids.

International approvals certify use in hazardous areas.

Your benefits

- Use in safety systems requiring functional safety to SIL2/SIL3 in accordance with IEC 61508/IEC 61511-1
- Optimally adapted to the process with a wide range of materials for corrosion-resistant coating
- Large number of process connections to choose from
 - Flanges for various standards
 - Universal usage
- Wide range of electronics, e.g. NAMUR, relay, thyristor, PFM signal output: suitable connection for every process control system
- PROFIBUS PA protocol: for commissioning and maintenance
- No adjustment: quick, low-cost startup
- No mechanically moving parts: no maintenance
no wear, long operating life
- Monitoring of fork for damage: guaranteed function
- FDA-approved material (PFA Edlon)

Table of contents

Application	4	Connectable load	11
Point level detection	4	Electronic insert FEL57 (PFM)	12
Function and system design	4	Power supply	12
Measuring principle	4	Electrical connection	12
Modularity	4	Output signal	13
Electronic versions	5	Signal on alarm	13
Electronic version for density measurement	5	Connectable load	13
Galvanic isolation	5	Electronic insert FEL50A (PROFIBUS PA)	14
Design	5	Power supply	14
Input	5	Electrical connection	14
Measured variable	5	Output signal	15
Measuring range (detection range)	5	Signal on alarm	15
Density	5	Electronic insert FEL50D (density)	16
Electronic insert FEL51 (AC 2-wire)	6	Power supply	16
Power supply	6	Electrical connection	16
Electrical connection	6	Signal on alarm	16
Output signal	6	Adjustment	16
Signal on alarm	6	Operating principle	17
Connectable load	6	Light signals	17
Electronic insert FEL52 (DC PNP)	7	Connection and function	18
Power supply	7	Connecting cables	18
Electrical connection	7	Safety mode	18
Output signal	7	Switching time	18
Signal on alarm	7	Switch-on behavior	18
Connectable load	7	Performance characteristics	18
Electronic insert FEL54 (AC/DC with relay output) ..	8	Reference operating conditions	18
Power supply	8	Maximum measured error	18
Electrical connection	8	Repeatability	18
Output signal	8	Hysteresis	18
Signal on alarm	8	Influence of medium temperature	18
Connectable load	8	Influence of medium density	18
Electronic insert FEL55 (8/16 mA)	9	Influence of medium pressure	18
Power supply	9	Operating conditions	19
Electrical connection	9	Installation	19
Output signal	9	Installation instructions	19
Signal on alarm	9	Examples of mounting	20
Connectable load	9	Orientation	21
Electronic insert FEL56 (NAMUR L-H edge)	10	Environment	22
Power supply	10	Ambient temperature range	22
Electrical connection	10	Ambient temperature limits	22
Output signal	10	Storage temperature	22
Signal on alarm	10	Climate class	22
Connectable load	10	Degree of protection	22
Electronic insert FEL58 (NAMUR H-L edge)	11	Vibration resistance	22
Power supply	11	Electromagnetic compatibility	22
Electrical connection	11		
Output signal	11		
Signal on alarm	11		

Medium conditions	23
Medium temperature	23
Thermal shock	23
Medium pressure pe	23
Test pressure	23
Pressure shock	23
State of aggregation	23
Density	23
Viscosity	23
Solids content	23
Mechanical construction	24
Design	24
Dimensions (in mm)	25
Weights	26
Material	27
Process connections	27
Human interface	28
Electronic inserts	28
Operating concept	28
Certificates and approvals	29
Certificates	29
Combinations of coatings, housings and electronic inserts	29
Ordering information	31
Liquiphant M FTL51C product structure	31
Accessories	34
Transparent cover	34
Cover with sight glass	34
Documentation	34
Operating Instructions	34
Technical Information	34
Functional safety (SIL)	35
Safety Instructions (ATEX)	35
Safety Instructions (NEPSI)	36
Control Drawings	36
System information	36

Application

Point level detection

Maximum or minimum detection in tanks or pipes containing all kinds of liquids, including use in hazardous areas. Particularly suitable for very aggressive liquids that to high level of corrosion protection.

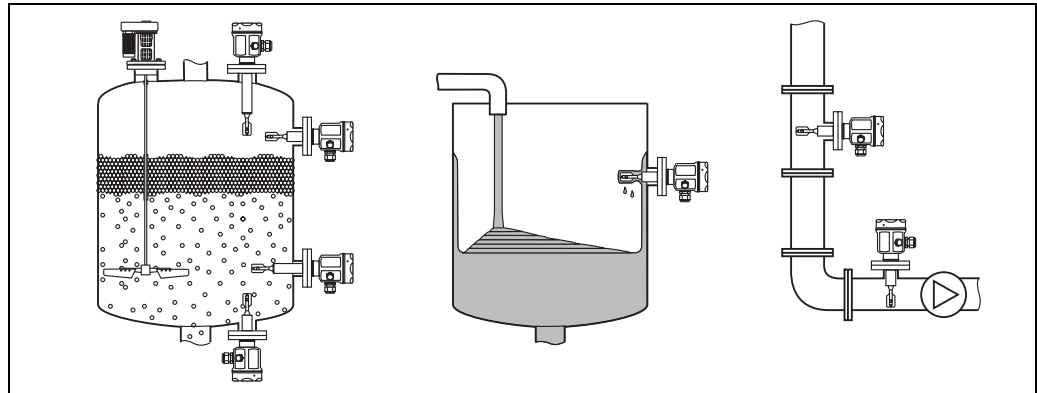

L00-FTL51Cxx-11-05-xx-xx-001

Function and system design

Measuring principle

The sensor's fork vibrates at its intrinsic frequency. This frequency is reduced when covered with liquid. This change in frequency causes the point level switch to switch.

Modularity

Point level switch

Liquiphant M FTL with electronic versions
FEL51, FEL52, FEL54

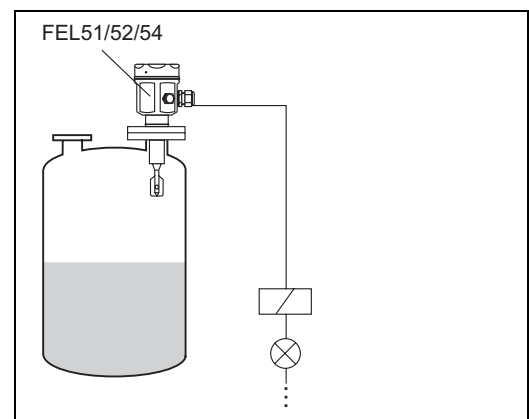

L00-FTL51Cxx-15-05-xx-xx-000

Point level switch

Liquiphant M FTL with electronic versions
FEL55, FEL56, FEL57, FEL58
for connecting to a separate switching unit
or an isolating amplifier FEL50A
for connecting to a PROFIBUS PA segment

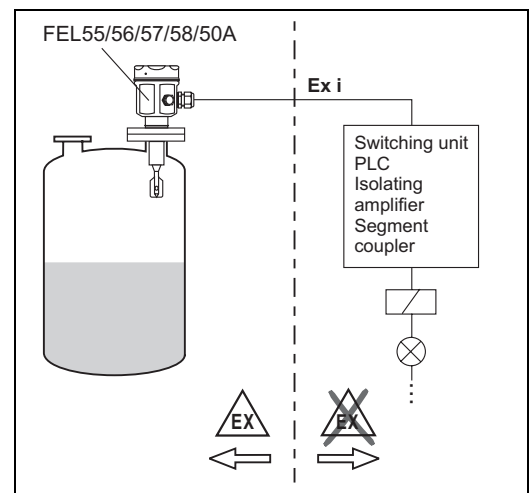

L00-FTL51Cxx-15-05-xx-en-000

Electronic versions	<p>FEL51: Two-wire AC version; Switches the load directly into the power supply circuit via an electronic switch.</p> <p>FEL52: Three-wire DC version; Switches the load via the transistor (PNP) and separate connection.</p> <p>FEL54: Universal current version with relay output; Switches the loads via 2 floating change-over contacts.</p> <p>FEL55: For separate switching unit; signal transmission 16/8 mA on two-wire cabling.</p> <p>FEL56: For separate switching unit; signal transmission L-H edge 0.6 to 1.0 / 2.2 to 2.8 mA to EN 50227 (NAMUR) on two-wire cabling.</p> <p>FEL58: For separate switching unit; signal transmission H-L edge 2.2 to 3.5 / 0.6 to 1.0 mA to EN 50227 (NAMUR) on two-wire cabling. Checking of connecting cabling and other devices by pressing a key on the electronic insert.</p> <p>FEL57: For separate switching unit; PFM signal transmission; Current pulses superposed on the power supply along the two-wire cabling. Cyclical checking from the switching unit without changing levels.</p> <p>FEL50A: For connecting to PROFIBUS PA; Cyclic and acyclic data exchange acc. to PROFIBUS-PA Profile 3.0 Discrete Input</p>
----------------------------	---

Electronic version for density measurement	FEL50D: For connecting to Density Computer FML621
---	--

Galvanic isolation	<p>FEL51, FEL52, FEL50A: Between sensor and power supply</p> <p>FEL54: Between sensor and power supply and load</p> <p>FEL55, FEL56, FEL57, FEL58, FEL50D: See connected switching unit</p>
---------------------------	---

Design	FTL51C: The flange, extension pipe and tuning fork are coated.
---------------	---

Input

Measured variable	Level (limit value)
Measuring range (detection range)	Depends on the mounting point or the length of the sensor with an extension pipe (up to 3000 mm for synthetic coating, and up to 1200 mm for enamel coating)
Density	Adjustment on the electronic insert > 0.5 g/cm ³ or > 0.7 g/cm ³ (other on request)

Electronic insert FEL51 (AC 2-wire)

Power supply

Supply voltage: 19 to 253 V AC
 Power consumption: < 0.83 W
 Residual current consumption: < 3.8 mA
 Short-circuit protection
 Overvoltage protection FEL51: overvoltage category III

Electrical connection

Two-wire AC connection

Switches the load directly into the power supply circuit via an electronic switch.

Always connect in series with a load!

Check the following:

- The residual current in blocked state (up to 3.8 mA)
- That for low voltage
 - the voltage drop across the load is such that the minimum terminal voltage at the electronic insert (19 V) when blocked is not undershot.
 - the voltage drop across the electronics when switched through is observed (up to 12 V)
- That a relay cannot de-energize with holding power below 3.8 mA.
 If this is the case, a resistor should be connected parallel to the relay. An RC module is available under the modification number MVT2Y1278.
- When selecting the relay, pay attention to the holding power / rated power (see "Connectable load")

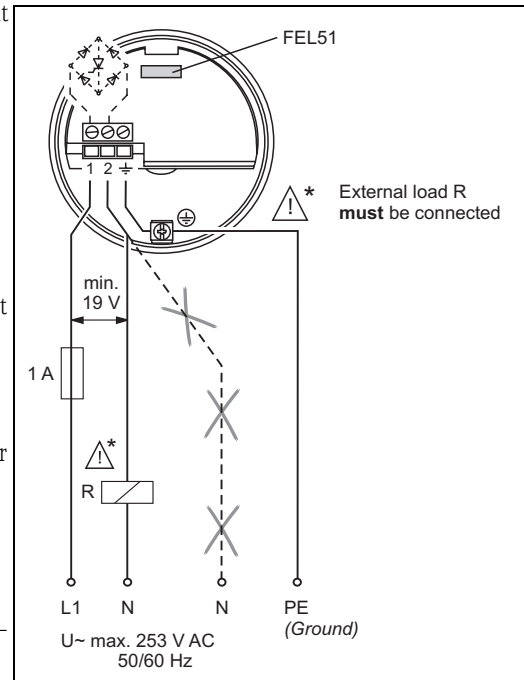

L00-FTL5xxxx-04-05-xx-xx-007

Output signal

I_L = load current (switched through)

< 3.8 mA = residual current (blocked)

☀ = lit

● = unlit

L00-FTL2xxxx-07-05-xx-xx-000

Safety mode	Level	Output signal	LEDs	
			green	red
Max.		1 I_L → 2	☀	●
		1 < 3.8 mA → 2	☀	☀
Min.		1 I_L → 2	☀	●
		1 < 3.8 mA → 2	☀	☀

L00-FTL5xxxx-04-05-xx-xx-001

Signal on alarm

Output signal on power failure or in the event of damaged sensor: < 3.8 mA

Connectable load

- For relays with a minimum holding power/rated power > 2.5 VA at 253 V AC (10 mA) or > 0.5 VA at 24 V AC (20 mA)
- Relays with a lower holding power/rated power can be operated by means of an RC module connected in parallel.
- For relays with a maximum holding power/rated power < 89 VA at 253 AC or < 8.4 VA at 24 V AC
- Voltage drop across FEL51 max. 12V
- Residual current with blocked electrical switch: max. 3.8 mA.
- Load switched directly into the power supply circuit via the thyristor.

Transient (40 ms) max. 1.5 A, max. 375 VA at 253 V or max. 36 VA at 24 V (not short-circuit proof)

Electronic insert FEL52 (DC PNP)

Power supply

Supply voltage: 10 to 55 V DC
 Ripple: max. 1.7 V, 0 to 400 Hz
 Current consumption: max. 15 mA
 Power consumption: max. 0.83 W
 Reverse polarity protection
 Overvoltage protection FEL52: overvoltage category III

Electrical connection

Three-wire DC connection

Preferably used with programmable logic controllers (PLC).
 DI module as per EN 61131-2.
 Positive signal at switching output of the electronics (PNP);
 Output blocked on reaching limit.

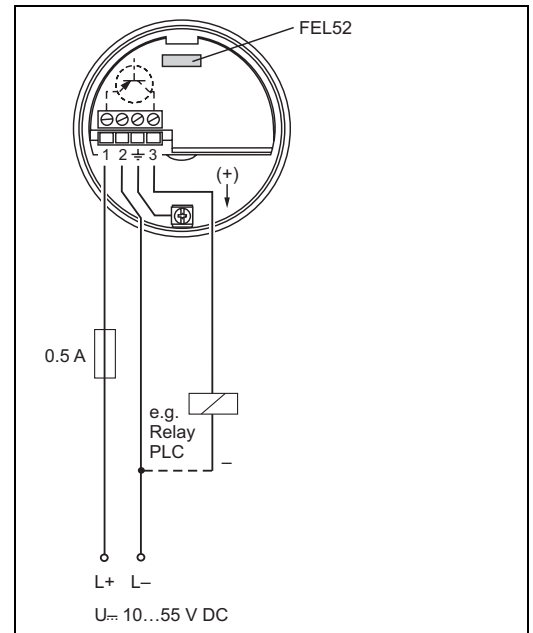

L00-FTL5xxxx-04-05-xx-en-001

Output signal

I_L = load current (switched through)
 $< 100 \mu A$ = residual current (blocked)

☀ = lit
 ● = unlit

L00-FTL2xxxx-07-05-xx-xx-000

Safety mode	Level	Output signal	LEDs	
			green	red
Max.		$L+ \xrightarrow{I_L} +$ 1 → 3	☀	●
		$1 \xrightarrow{< 100 \mu A} 3$	☀	☀
Min.		$L+ \xrightarrow{I_L} +$ 1 → 3	☀	●
		$1 \xrightarrow{< 100 \mu A} 3$	☀	☀

L00-FTL5xxxx-04-05-xx-xx-004

Signal on alarm

Output signal on power failure or in the event of damaged sensor: $< 100 \mu A$

Connectable load

- Load switched via the transistor and separate PNP connection, max. 55 V DC
- Load current max. 350 mA (pulsed overload and short-circuit protection)
- Residual current $< 100 \mu A$ (with transistor blocked).
- Capacitance load max. $0.5 \mu F$ at 55 V, max. $1.0 \mu F$ at 24 V
- Residual voltage $< 3 V$ (with transistor switched through);

Electronic insert FEL54 (AC/DC with relay output)

Power supply

Supply voltage: 19 to 253 V AC, 50/60 Hz or 19 to 55 V DC
 Power consumption: max. 1.3 W
 Reverse polarity protection
 Overvoltage protection FEL54: overvoltage category III

Electrical connection

Universal current connection with relay output

Power supply:
 Please note the different voltage ranges for AC and DC.

Output:
 When connecting an instrument with high inductance, provide a spark arrester to protect the relay contact.
 A fine-wire fuse (depending on the load connected) protects the relay contact on short-circuiting.
 Both relay contacts switch simultaneously.

* When jumpered, the relay output works with NPN logic.

** See "Connectable load"

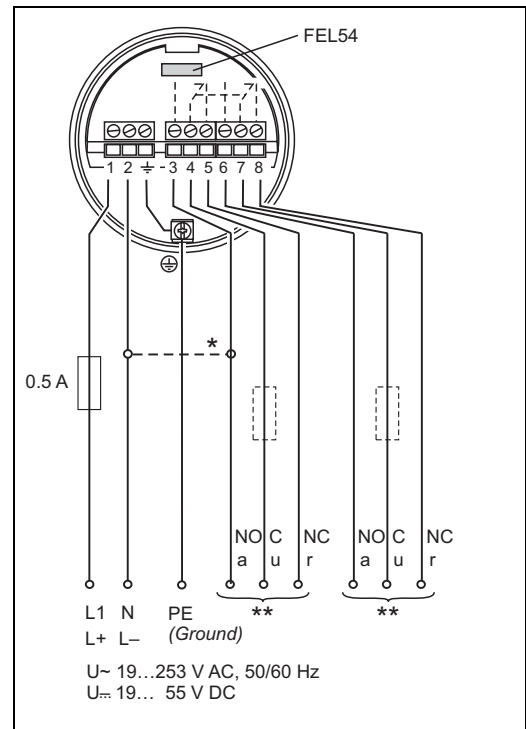

Output signal

- = relay energized
- = relay de-energized
- = lit
- = unlit

L00-FTL2xxxx-07-05-xx-xx-001

Safety mode	Level	Output signal	LEDs	
			green	red
Max.				
Min.				

L00-FTL5xxxx-04-05-xx-xx-003

Signal on alarm

Output signal on power failure or in the event of damaged sensor: relay de-energized

Connectable load

- Loads switched via 2 floating change-over contacts (DPDT).
- I~ max. 6 A (Ex de 4 A), U~ max. 253 V AC; P~ max. 1500 VA, cos φ = 1, P~ max. 750 VA, cos φ > 0.7
- I= max. 6 A (Ex de 4 A) bis 30 V DC, I= max. 0.2 A to 125 V
- When connecting a low-voltage circuit with double isolation according to IEC 1010, the following applies: total of voltages of relay output and power supply max. 300 V.

Electronic insert FEL55 (8/16 mA)

Power supply

Supply voltage: 11 to 36 V DC
 Power consumption: < 600 mW
 Reverse polarity protection
 Overvoltage protection FEL55: overvoltage category III

Electrical connection

Two-wire connection for separate switching unit

For connecting to programmable logic controllers (PLCs) for example, AI module 4 to 20 mA to EN 61131-2. Output signal jump from high to low current on limit.

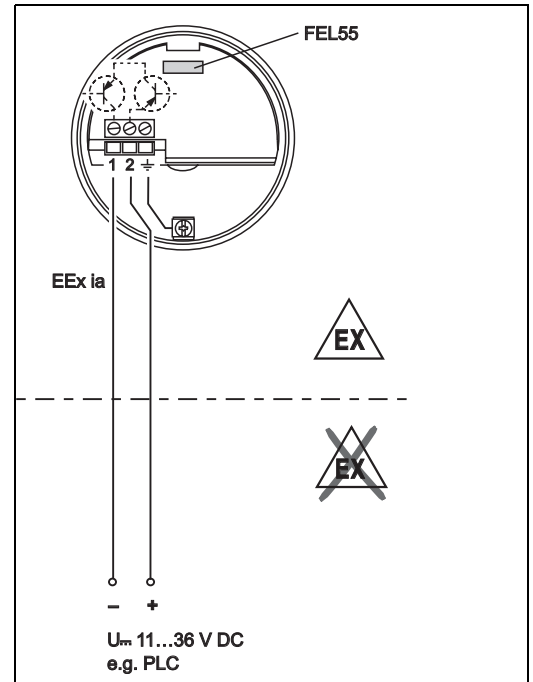

L00-FTL5xxxx-04-05-xx-en-000

Output signal







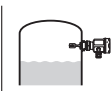

$\sim 16 \text{ mA} = 16 \text{ mA} \pm 5 \%$

$\sim 8 \text{ mA} = 8 \text{ mA} \pm 6 \%$

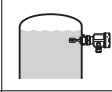
 = lit

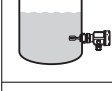
 = unlit

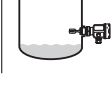
L00-FTL2xxxx-07-05-xx-xx-000

Safety mode	Level	Output signal	LEDs	
			green	red
Max.		+ 2 $\xrightarrow{\sim 16 \text{ mA}}$ 1		
		+ 2 $\xrightarrow{\sim 8 \text{ mA}}$ 1		
Min.		+ 2 $\xrightarrow{\sim 16 \text{ mA}}$ 1		
		+ 2 $\xrightarrow{\sim 8 \text{ mA}}$ 1		

L00-FTL5xxxx-04-05-xx-xx-000

Signal on alarm

Output signal on power failure or in the event of damaged sensor: < 3.6 mA

Connectable load

- $R = (U - 11 \text{ V}) : 16.8 \text{ mA}$
- $U = \text{connection voltage: } 11 \text{ to } 36 \text{ V DC}$

Example:
 PLC with 250 Ω with 2-wire version

$250 \Omega = (U - 11 \text{ V}) / 16.8 \text{ mA}$

$4.2 [\Omega/\text{A}] = U - 11 \text{ V}$

$U = 15.2 \text{ V}$

Electronic insert FEL56 (NAMUR L-H edge)

Power supply

Power consumption: < 6 mW at I < 1 mA; < 38 mW at I = 2.8 mA
 Connection data interface: IEC 60947-5-6

Electrical connection

Two-wire connection for separate switching unit

For connecting to isolating amplifiers acc. to NAMUR (IEC 60947-5-6), e.g. FTL325N, FTL375N from Endress+Hauser. Output signal jump from low to *high current on limit*.

(L-H edge)

Connecting to multiplexer:
 Set clock time to min. 2 s.

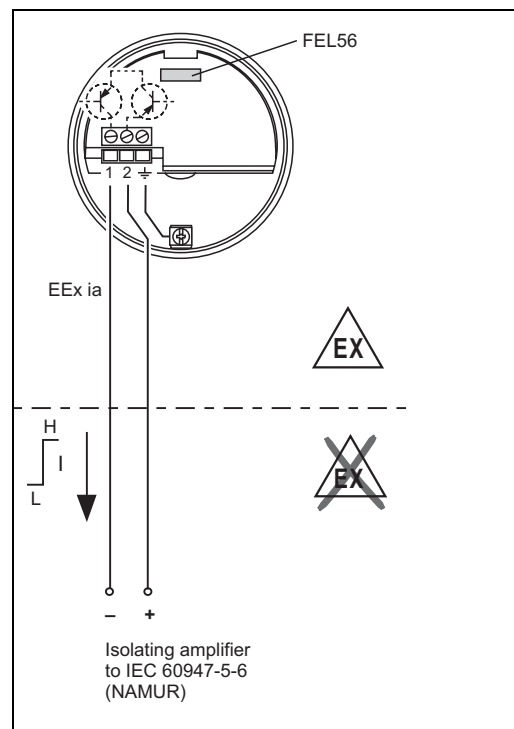

L00-FTL5xxxx-04-05-xx-xx-004

Output signal

- = lit
- = flashes
- = unlit

L00-FTL5xxxx-07-05-xx-xx-002

Safety mode	Level	Output signal	LEDs	
			green	red
Max.		+ 0.6 ... 2 1.0 mA → 1		
		+ 2.2 ... 2 2.8 mA → 1		
Min.		+ 0.6 ... 2 1.0 mA → 1		
		+ 2.2 ... 2 2.8 mA → 1		

L00-FTL5xxxx-04-05-xx-xx-003

Signal on alarm

Output signal in the event of damaged sensor: > 2.2 mA

Connectable load

- See Technical Data of the isolating amplifier connected according to IEC 60947-5-6 (NAMUR)

Electronic insert FEL58 (NAMUR H-L edge)

Power supply

Power consumption: < 6 mW at I < 1 mA; < 38 mW at I = 3.5 mA
 Connection data interface: IEC 60947-5-6

Electrical connection

Two-wire connection for separate switching unit

For connecting to isolating amplifiers acc. to NAMUR (IEC 60947-5-6), e.g. FTL325N, FTL375N from Endress+Hauser. Output signal jump from high to low current on limit.

(H-L edge)

Additional function:
 Test key on the electronic insert.
 Pressing the key breaks the connection to the isolating amplifier.



Note!

In Ex-d applications, the additional function can only be used if the housing is not exposed to an explosive atmosphere.

Connecting to multiplexer:
 Set clock time to min. 2 s.

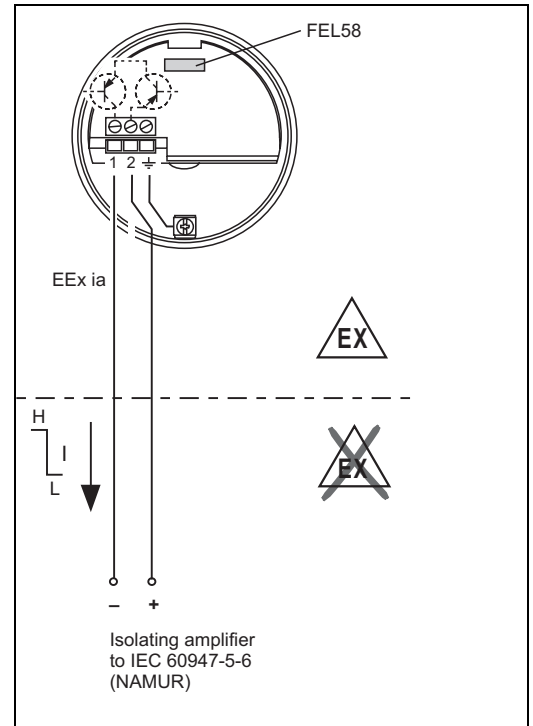

L00-FTL5xxxx-04-05-xx-en-002

Output signal

Safety mode	Level	Output signal	LEDs green yellow
Max.		+ 2.2 ... 3.5 mA 2 → 1	
		+ 0.6 ... 1.0 mA 2 → 1	
Min.		+ 2.2 ... 3.5 mA 2 → 1	
		+ 0.6 ... 1.0 mA 2 → 1	

= lit
 = flashes
 = unlit

L00-FTL5xxxx-07-05-xx-xx-002

L00-FTL5xxxx-04-05-xx-xx-002

Signal on alarm

Output signal in the event of damaged sensor: < 1.0 mA

Connectable load

- See Technical Data of the isolating amplifier connected according to IEC 60947-5-6 (NAMUR)
- Connection also to isolating amplifiers which have special safety circuits (I > 3.0 mA)

Electronic insert FEL57 (PFM)

Power supply

Supply voltage: 9.5 to 12.5 V DC
 Current consumption: 10 to 13 mA
 Power consumption: < 150 mW
 Reverse polarity protection

Electrical connection

Two-wire connection for separate switching unit

For connecting to Nivotester switching units FTL320, FTL325P, FTL370, FTL372, FTL375P (also with cyclical checking) from Endress+Hauser. Output signal jump of the PFM signal from high to low frequency when sensor is covered. Switching between minimum/maximum safety in the Nivotester.

Additional function “cyclical checking”:
 After interruption of the power supply, a test cycle is activated which checks the sensor and electronics without any change in level. Approved for overfill protection acc. to WHG (German Water Resources Act). The following can be switched at the electronic insert:

– Standard (STD):

Corrosion of the fork unlikely;
 simulation approx. 8 s
 tuning fork exposed – covered – exposed.
 This setting tests level reporting in the Nivotester during cyclical checking.

– Extended (EXT):

Corrosion of the fork possible;
 Simulation approx. 41 s: tuning fork exposed – covered – corroded – exposed.
 This setting tests level reporting and alarm notification in the Nivotester during cyclical checking.

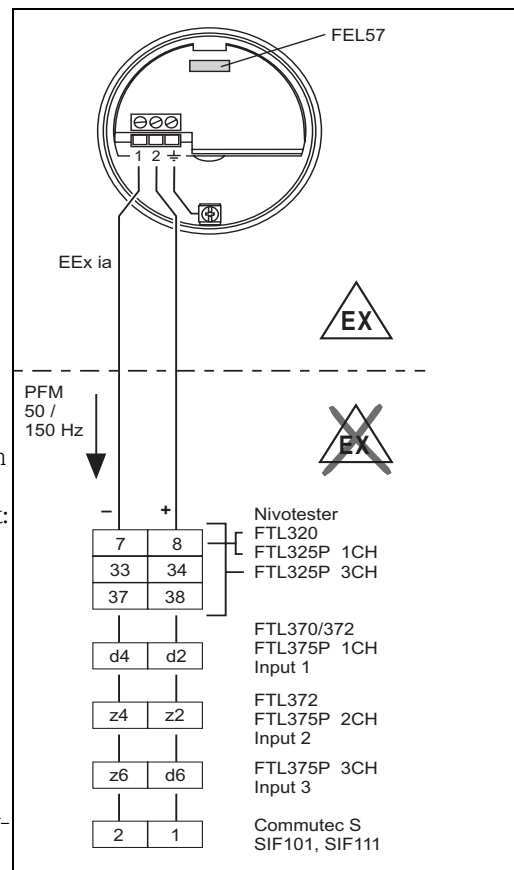

The check is activated and monitored at the switching unit.

Switching behavior of the connected device:

Fail-safe mode set at switching unit	Setting at FEL57	Fork	Switching status of relay in switching unit	
			on = energised	off = de-energised
			⚡ Test start (power off) > 3 s	⚡ End of test start (power on)
Max.	STD	free	on	off
Max.	EXT	free	on	off
Max.	STD	covered	off	off
Max.	EXT	covered	off	off
Min.	STD	free	off	on
Min.	EXT	free	off	on
Min.	STD	covered	on	on
Min.	EXT	covered	on	on

L00-FTL5xxxx-05-05-xx-en-000

* De-energised on power supply failure

Please note this switching response and function of the plant especially when replacing a Liquiphant with an EL17Z or FEL37 electronic insert with a Liquiphant M with an FEL57 electronic insert.

Output signal

☀ = lit
● = unlit

L00-FTL2xxxx-07-05-xx-xx-000

Safety mode	Level	Output signal (PFM)	LEDs green yellow
		150 Hz	☀ ☀
		50 Hz	☀ ●

L00-FTL5xxxx-04-05-xx-xx-008

Signal on alarm

Output signal on power failure or in the event of damaged sensor: 0 Hz

Connectable load

- Floating relay contacts in the connected switching device Nivotester FTL320, FTL325P, FTL370, FTL372, FTL375P
- For contact load, see the Technical Data of the switching unit.

Electronic insert FEL50A (PROFIBUS PA)

Power supply

Bus voltage: 9 to 32 V DC

Bus current:

- 12.5 mA +/- 1.0
mA (software version: 01.03.00, hardware version: 02.00)
- 10.5 mA +/- 1.0
mA (software version: 01.03.00, hardware version: 01.00)

Electrical connection

Two-wire connection for power supply and data transfer

For connecting to PROFIBUS PA

Additional functions:

- Digital communication enables the representation, reading and editing of the following parameters:
Fork frequency, switch-on frequency, switch-off frequency, switch-on time and switch-off time, status, measured value, density switch.
- Matrix locking possible
- Switch to WHG mode possible (WHG approval).
- For a detailed description, see BA198F
- You can also visit www.profibus.com for more information

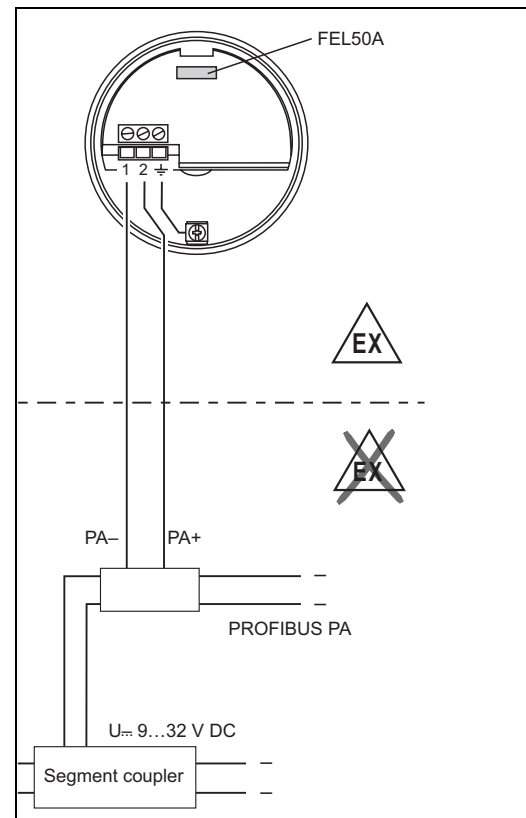

L00-FTL5xxxx-04-05-xx-en-005

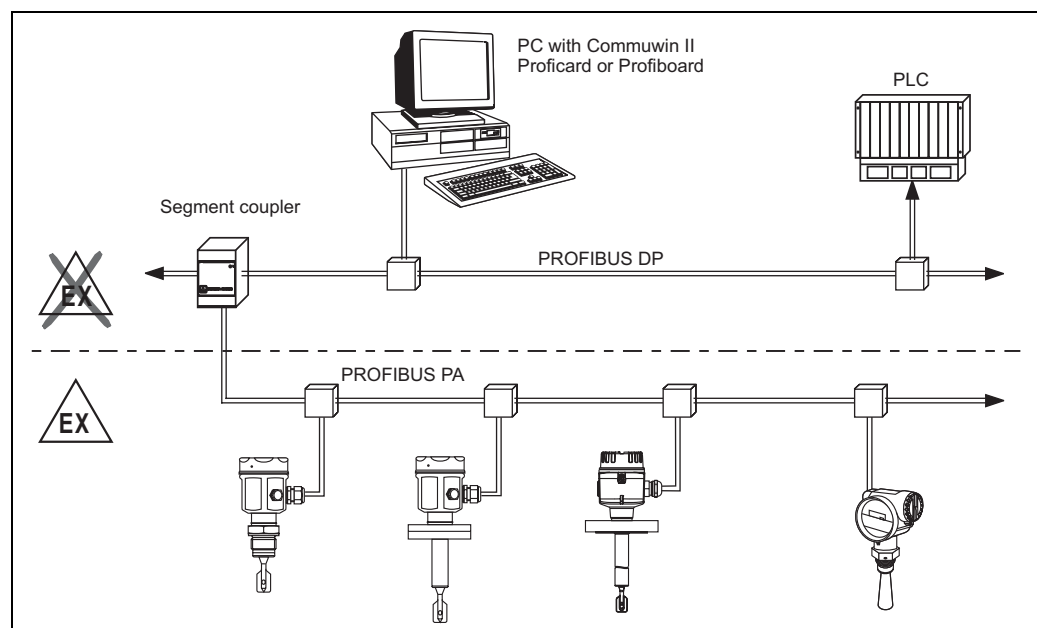

L00-FTL5xxxx-04-05-xx-en-006

Output signal

☀ = lit
 ● = unlit

L00-FTL2xxxx-07-05-
 xx-xx-000

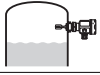
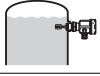
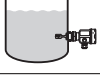
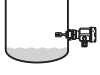
Setting	Level	LEDs		FEL50A
		green	yellow	
not inverted		☀	●	OUT_D = 0 PA bus signal
		☀	☀	OUT_D = 1 PA bus signal
inverted		☀	☀	OUT_D = 1 PA bus signal
		☀	●	OUT_D = 0 PA bus signal

L00-FTL5xxxx-04-05-xx-xx-000

Signal on alarm

- Failure information can be opened using the following interfaces:
 Yellow LED flashing, status code, diagnostic code; see BA198F

Electronic insert FEL50D (density)

Power supply

Frequency range: 300 to 1500 Hz
 Signal level: 4 mA
 Pulse height: 16 mA
 Pulse width: 20 μ S

Electrical connection

Two-wire connection at Density Computer FML621

For connecting to the density and concentration computer FML621.

The output signal is based on pulse technology.
 With the aid of this signal, the fork frequency is constantly forwarded to the switching unit.



Caution!

Operation with other switching units, such as FTL325P, is not permitted.

This electronic insert cannot be installed in devices that were ori

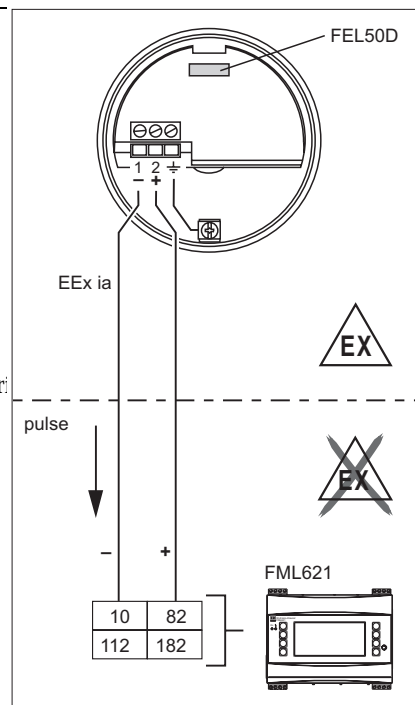

TI420Fen004

Signal on alarm

Output signal on power failure or in the event of damaged sensor: 0 Hz

Adjustment

In the Liquiphant M modular system, the option of an adjustment is also provided in addition to the electronics (see feature 60: "Accessories").

There are three types of adjustment:

Standard adjustment (see ordering information for additional options, basic version A)

- Here, two fork parameters are determined to describe the sensor characteristics, indicated in the adjustment report and provided with the product.

These parameters must be transmitted to the Density Computer FML621.

Special adjustment (see ordering information for additional options, special adjustment, density H₂O (K) or special adjustment, density H₂O with 3.1 certificate (L))

- Here, three fork parameters are determined to describe the sensor characteristics, indicated in the adjustment report and provided with the product.

These parameters must be transmitted to the Density Computer FML621.

Greater accuracy is achieved with this type of adjustment (see also "Performance characteristics").

Field adjustment

- During field adjustment, a density value actually determined by the customer is entered and the system is automatically adjusted to this value (wet adjustment).



Note!

Further information on Liquiphant M Density is available in Technical Information TI420F. This document is available for download at www.endress.com => Download.

Operating principle

Measuring the density of a liquid medium in pipes and tanks. Also suitable for use in hazardous areas, and preferably for applications in the chemical and food industry.

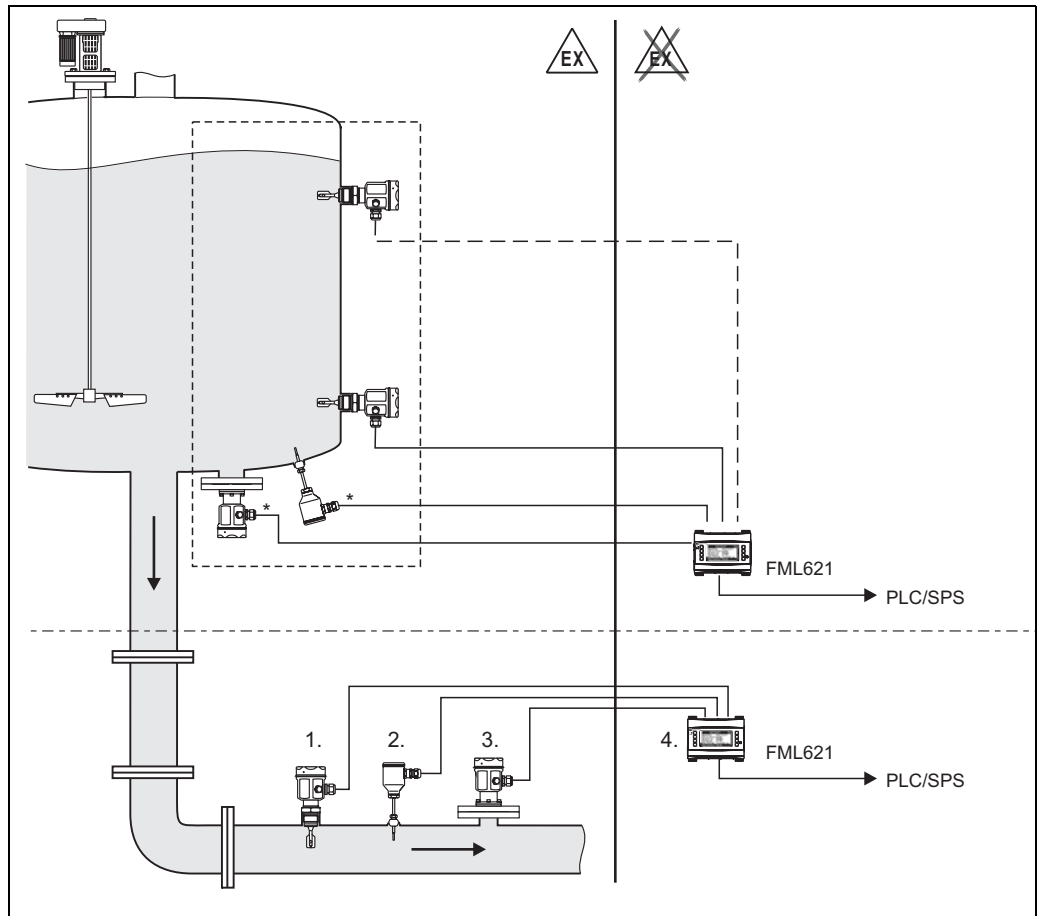

* Pressure and temperature information required depending on the application.

1. Liquiphant M sensor with electronic insert FEL50D (pulse output);
2. Temperature sensor (e.g. 4 to 20 mA output);
3. Pressure transmitter (4 to 20 mA output);
4. Liquiphant density and concentration computer FML621 with display and operating unit

T1420Fxx016

Light signals

LED	Symbol	Information
Yellow w		Measurement valid
		Unstable process situation
		Maintenance required
Green		Power on
		Power off
Red		No fault
		Maintenance required
		Device failure

Connection and function

Connecting cables	<ul style="list-style-type: none"> ■ Electronic inserts: cross-section max. 2.5 mm²; strand in ferrule to DIN 46228 ■ Protective earth in housing: cross-section max. 2.5 mm² ■ External equipotential bonding connection on housing: cross-section max. 4 mm²
--------------------------	--

Safety mode	<p>Minimum/maximum residual current safety selectable on electronic insert. (with FEL57 on Nivotester only)</p> <p>Max. = maximum safety: The output switches to the power fail response when the fork is covered For use with overflow protection for example</p> <p>Min. = minimum safety: The output switches to the power fail response when the fork is exposed For use with dry running protection for example</p>
--------------------	--

Switching time	<p>When fork is covered: approx. 0.5 s When fork is exposed: approx. 1.0 s (Other switching times on request.)</p> <p>Additionally configurable for PROFIBUS PA: 0.5-60 s</p>
-----------------------	---

Switch-on behavior	<p>When switching on the power supply, the output assumes the alarm signal. After max. 3 s it assumes the correct switching mode (exception: FEL57)</p>
---------------------------	---

Performance characteristics

Reference operating conditions	<p>Ambient temperature: 23 °C Medium temperature: 23 °C Medium density: 1 g/cm³ (water) Viscosity: 1 mm²/s Medium pressure p_e: 0 bar Sensor mounting: vertical from above Density switch: to > 0.7</p>
---------------------------------------	---

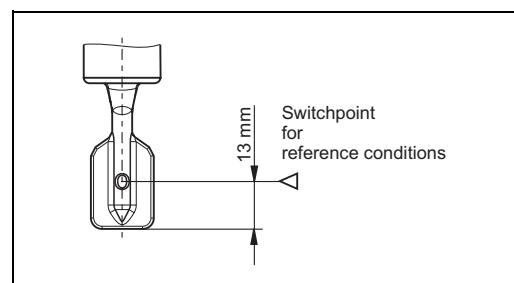

L00-FTL5xxxx-06-05-xx-en-000

Maximum measured error	Max. +/- 1 mm (at reference operating conditions)
-------------------------------	---

Repeatability	0.1 mm
----------------------	--------

Hysteresis	<p>ECTFE: approx. 2 mm PFA: approx. 2 mm Enamel: approx. 2.5 mm</p>
-------------------	---

Influence of medium temperature	<p>ECTFE: max. +1.4 mm to -2.8 mm (-50 °C to +120 °C) PFA: max. +1.4 mm to -2.8 mm (-50 °C to +150 °C) Enamel: max. +0.6 mm to -1.5 mm (-50 °C to +150 °C)</p>
--	--

Influence of medium density	Max. +4.8 mm to -3.5 mm (0.5 g/cm ³ to 1.5 g/cm ³)
------------------------------------	---

Influence of medium pressure	<p>ECTFE: max. 0 mm to -2.0 mm (0 bar to 40 bar) PFA: max. 0 mm to -2.0 mm (0 bar to 40 bar) Enamel: max. 0 mm to -1.0 mm (0 bar to 25 bar)</p>
-------------------------------------	---

Operating conditions

Installation

Installation instructions

Switch points \triangleright on the sensor depend on the mounting position, with reference to water, Density 1 g/cm³, 23 °C, p_e 0 bar.



Note!

The switch points of the Liquiphant **M** are at other positions to those of the previous version Liquiphant **II**.

Synthetic coating:

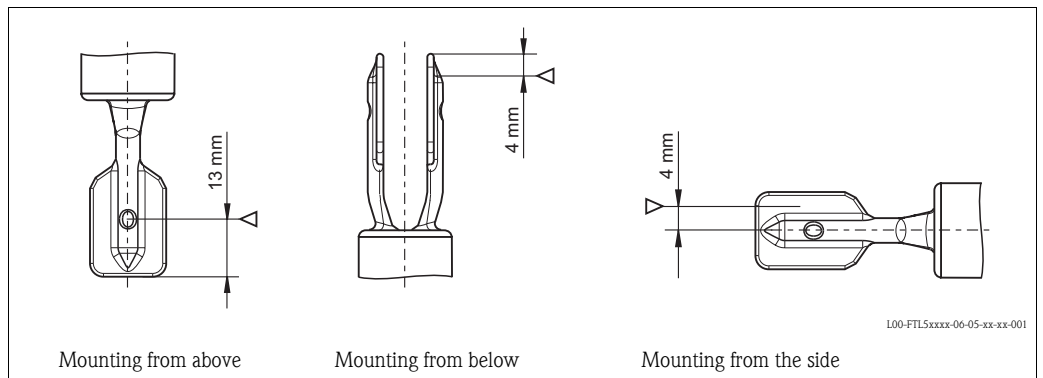

Enamel coating:

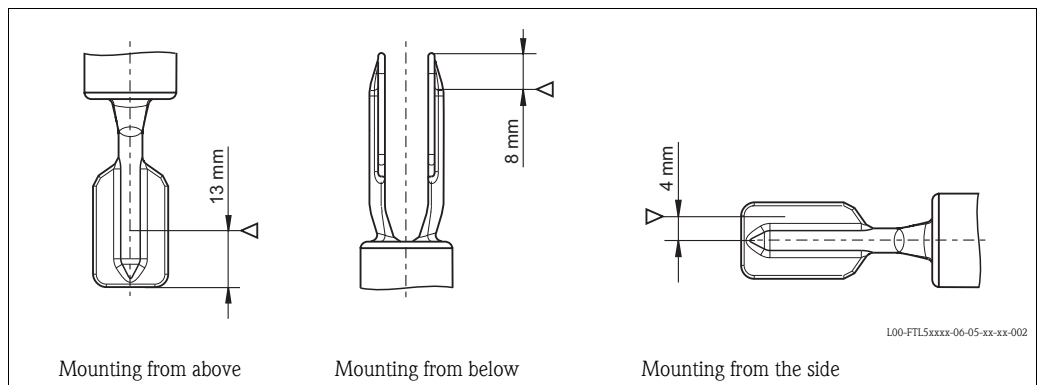

Examples of mounting

Optimum mounting, without problem even with high viscosity:

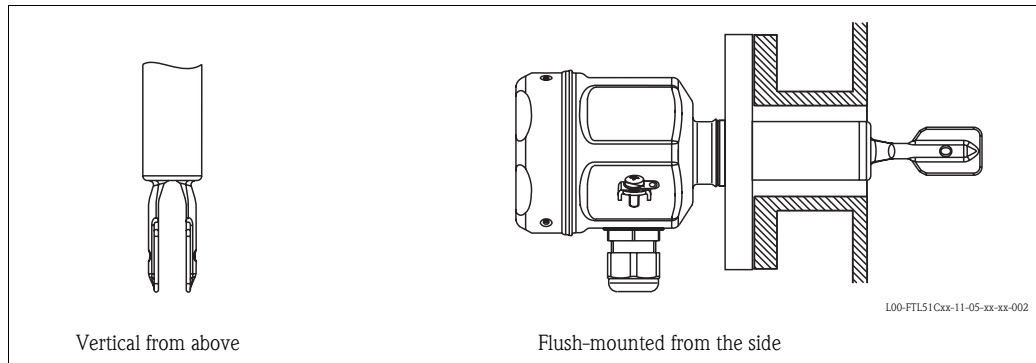

Note!

Position the fork so that the narrow edge of the tines is vertical to ensure that the liquid can run off easily.

With buildup on the tank walls:

* Ensure that there is sufficient distance between the buildup expected on the tank wall and the fork.

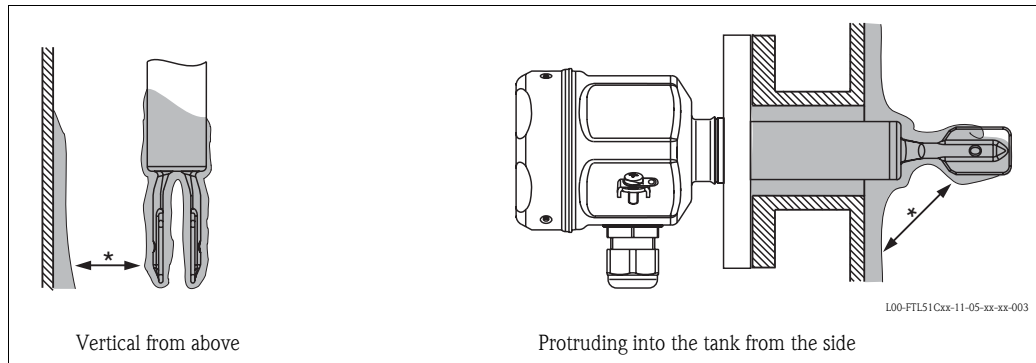

Mounting positions with low viscosity (up to 2000 mm²/s):

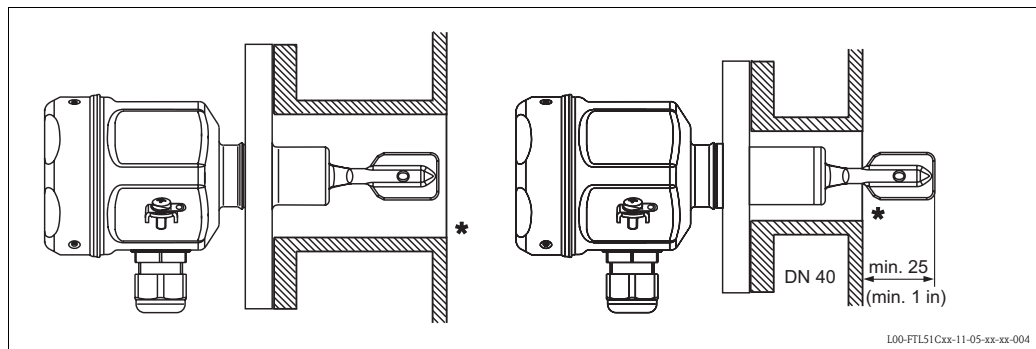

* Deburr the nozzle surfaces

Mounting in piping from 2"

Flow velocities up to 5 m/s for viscosity 1 mm²/s and density 1 g/cm³.
 (Check the function for other medium conditions.)

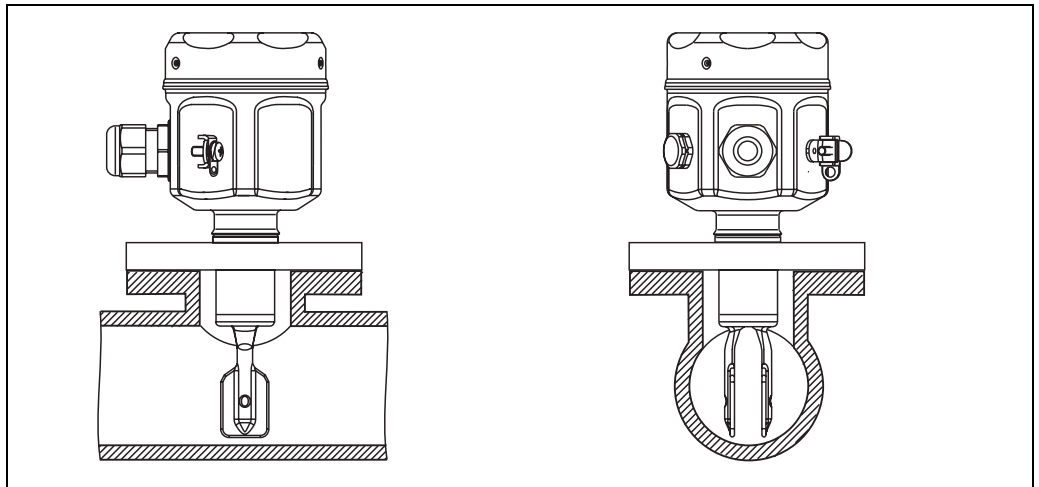

L00-FTL51Cxxx-11-05-xx-xx-005

Liquiphant M FTL51C
 in the event of severe dynamic load.

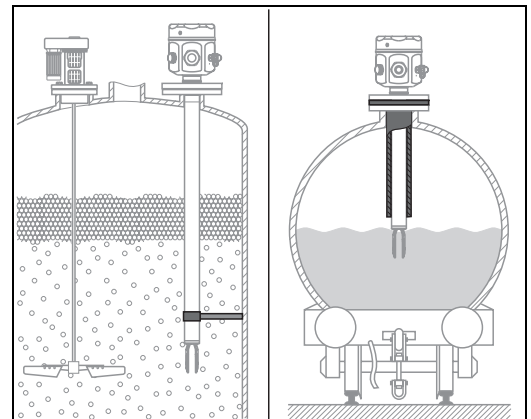

L00-FTL5xxxx-11-05-xx-xx-005

Ensure adequate space outside the tank for mounting, connection and configuration

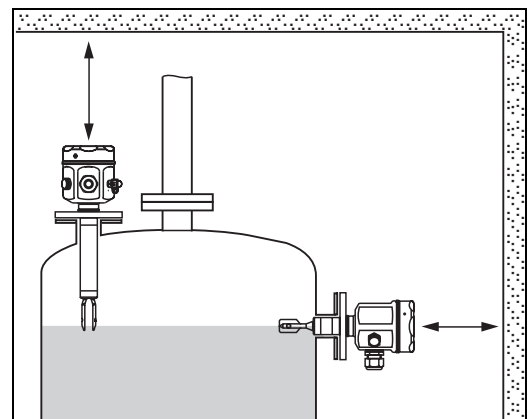

L00-FTL51Cxxx-11-05-xx-xx-005

Orientation

FTL51C with short pipe (up to approx. 500 mm) - any position,
 FTL51C with long pipe - vertical

Environment

Ambient temperature range Permitted ambient temperature T_a at the housing depending on the medium temperature T_p in the tank:

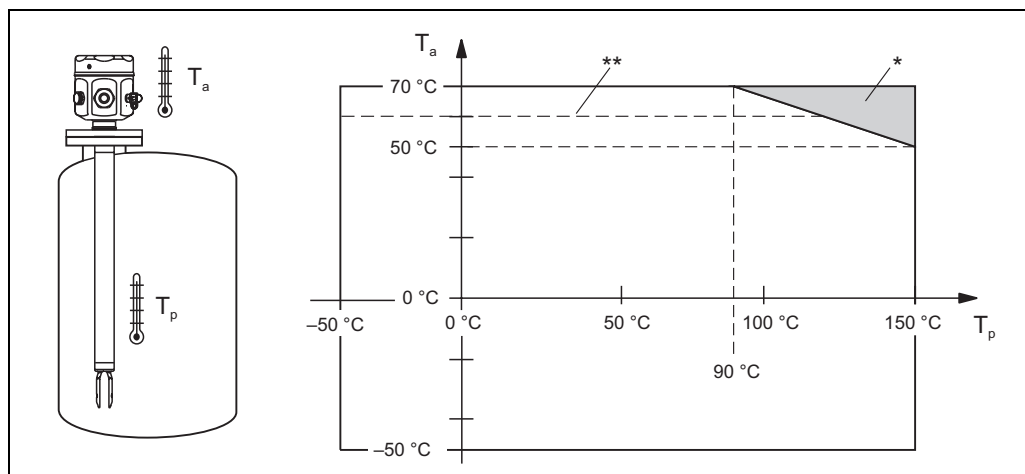

* Additional temperature range for devices with a temperature spacer or pressure tight feed-through.
Maximum ambient temperature with FEL50D/FEL50A in hazardous areas.

**

Medium temperatures up to 230 °C on request!

The difference in temperature between the process and ambient side ($T_p - T_a$) of the flange with ECTFE and PFA may not exceed 60 °C. For this reason, the flange might have to be included in the tank insulation where necessary.

Ambient temperature limits -50 °C to +70 °C (function with restricted data)

Storage temperature -50 °C to +80 °C

Climate class Climate protection to IEC 68, Part 2-38, Fig. 2a

Degree of protection

Types of housing	IP65	IP66*	IP67*	IP68*	IP69k	NEMA4X**
Polyester housing F16	-	X	X	-	-	X
Stainless steel housing F15	-	X	X	-	-	X
Aluminum housing F17	X	X	X	-	-	X
Aluminum housing F13	X	X	-	X***	-	X
Stainless steel housing F27	-	X	-	X	-	4x / 6P
Aluminum housing T13 with separate connection compartment (EEx d)	X	X	-	X***	-	4x / 6P

* As per EN60529

** As per NEMA 250

*** Only with M20 cable entry or G1/2 thread

Vibration resistance To IEC 68, Part 2-6 (10 to 55 Hz, 0.15 mm, 100 cycles)

Electromagnetic compatibility Interference emission to EN 61326, Electrical Equipment Class B
Interference immunity to EN 61326; Annex A (Industrial) and NAMUR Recommendation NE 21 (EMC)

Medium conditions

Medium temperature	ECTFE: -50 °C to +120 °C PFA: -50 °C to +150 °C/up to 230 °C on request Enamel: max. -50 °C to +150 °C/up to 200 °C on request
Thermal shock	Max. 120 °C/s
Medium pressure p_e	<p>The following values apply over the entire temperature range. Pay attention to exceptions for flange process connections!</p> <ul style="list-style-type: none"> ■ ECTFE: -1 to +40 bar ■ PFA: -1 to +40 bar ■ Enamel: max. -1 to +25 bar <p>Please refer to the standards listed for the permitted pressure values of the flanges at higher temperatures:</p> <ul style="list-style-type: none"> ■ pR EN 1092-1: 2005 With regard to their stability-temperature property, the materials 1.4435 and 1.4404 are identical and are grouped together under 13E0 in EN 1092-1 Tab. 18. The chemical composition of the two materials can be identical. ■ ASME B 16.5a - 1998 Tab. 2-2.2 F316 ■ ASME B 16.5a - 1998 Tab. 2.3.8 N10276 ■ JIS B 2220 <p>The lowest value from the derating curves of the device and selected flange applies in each case.</p>
Test pressure	Max. 100 bar (1.5 times the medium pressure p_e); no function during test pressure Sensor burst pressure 200 bar
Pressure shock	Max. 20 bar/s
State of aggregation	Liquid
Density	$\geq 0.7 \text{ g/cm}^3 = \text{delivery status}$ $\geq 0.5 \text{ g/cm}^3$ * can be adjusted via switches
Viscosity	Max. 10000 mm ² /s
Solids content	Max. $\varnothing 5 \text{ mm}$

Mechanical construction

Design

Summary of all electrical and mechanical versions

Plug-in electronic inserts to mount in the housing

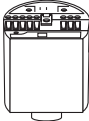
 <p>L00-FTL5xxxx-03-05-xx-xx-000</p>	FEL51:	Two-wire AC connection
	FEL52:	Three-wire DC connection PNP
	FEL54:	Universal current connection, 2 relay outputs
	FEL55:	Output 16/8 mA for separate switching unit
	FEL56:	Output 0.6 to 1.0 / 2.2 to 2.8 mA for separate switching unit (NAMUR)
	FEL58:	Output 2.2 to 3.5 / 0.6 to 1.0 mA for separate switching unit (NAMUR)
	FEL57:	Output 150/50 Hz, PFM, for separate switching unit (Nivotester)
	FEL50A: FEL50D:	Digital communication PROFIBUS PA Pulse output for Density Computer FML621

Housing

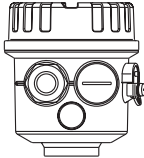
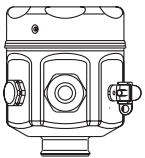
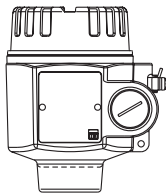
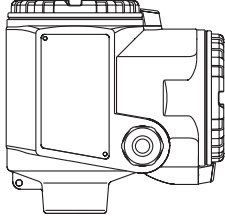
 <p>L00-FTL5xxxx-03-05-xx-xx-001</p>	 <p>L00-FTL5xxxx-03-05-xx-xx-002</p>	 <p>L00-FTL5xxxx-03-05-xx-xx-003</p>	 <p>L00-FTL5xxxx-03-05-xx-xx-004</p>
F16 Polyester (PBT)	F15 Stainless steel (316L)	F17/F13 Aluminum (also for EEx d), coated F27 Stainless steel (316L)	T13 Aluminum with separate connection compartment (also EEx de and EEx d), coated

Bushings

Temperature spacer and pressure tight feed-through

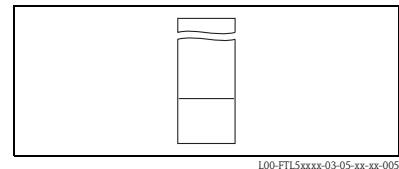

Process connections

Flanges* to DIN, ANSI, JIS from DN 40 / 1½"

* The following applies for DN 25/ANSI 1":

Pipe diameter (D) max. 24.2 mm, radius (R) max. 4 mm.

Take into account for counterflange!

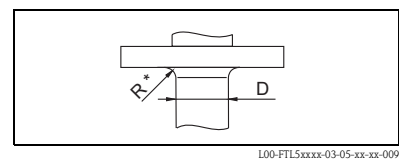

Sensors

With extension pipe up to 3 m

or special "length L II" (see also Page 24)

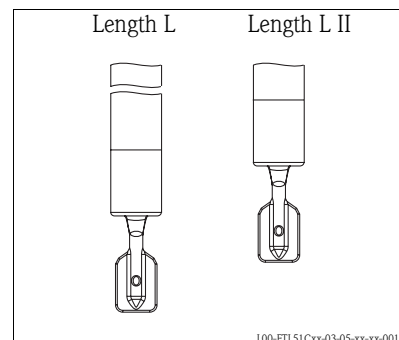

Dimensions (in mm)

Housing and sensor FTL51C
Polyester housing F16

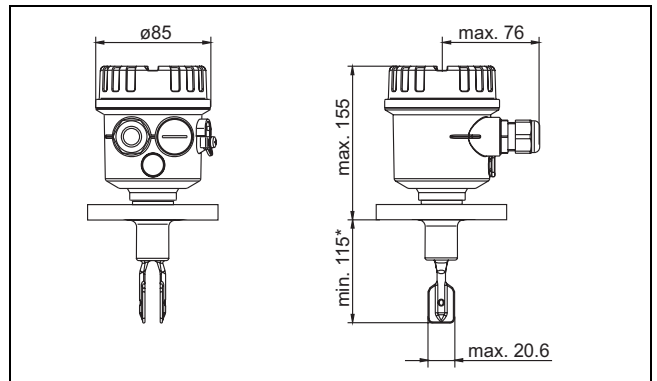

L00-FTL51Cxx-06-05-xx-xx-025

Stainless steel housing F15

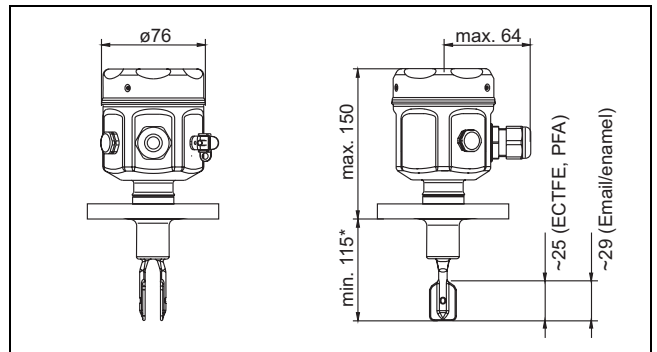

L00-FTL51Cxx-06-05-xx-xx-126

Aluminum housing F17/F13
Stainless steel housing (316L) F27

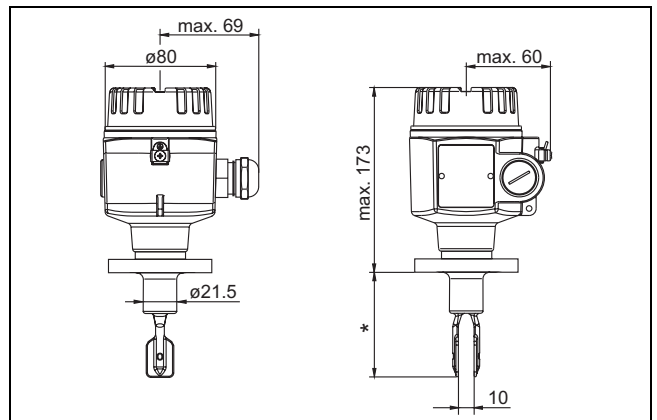

L00-FTL5xxxx-06-05-xx-xx-006

Aluminum housing T13 with separate
connection compartment

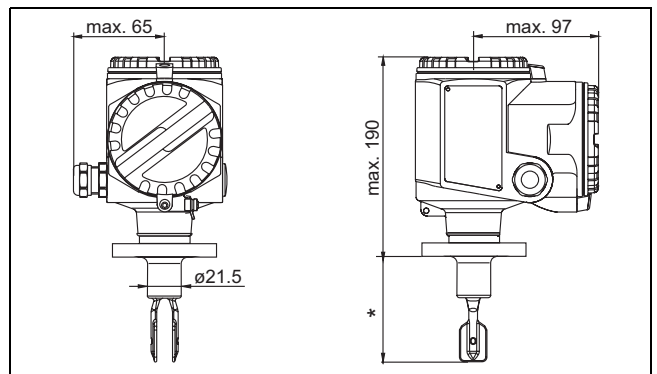

L00-FTL5xxxx-06-05-xx-xx-007

* This length is customer-specific.



Note!

The switch points of the Liquiphant **M** are at other positions to those of the previous version Liquiphant **II**.

Bushings: temperature spacer, pressure tight feed-through

Temperature spacer

Provides sealed insulation for the vessel and normal ambient temperatures for the housing.

Pressure tight feed-through

Protects the housing from pressures up to 40 bar if the sensor is damaged. Provides sealed insulation for the vessel and normal ambient temperatures for the housing.

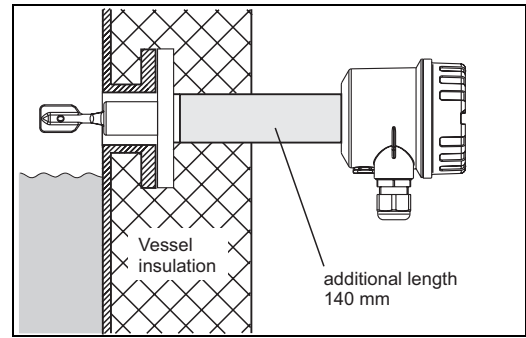

L00-FTL51Cxx-11-05-xx-xx-000

Process connections

Process connection		Dimensions	Accessories	Pressure Temperature
<p>Flanges:</p> <p>Synthetic coating ANSI B16.5 (FF) EN 1092-1 (Form A) JIS B 2238 (FF)</p> <p>Enamel coating ANSI B16.5 (RF) EN 1092-1 (Form B) JIS B 2238 (RF)</p>	<p>A## B## C## K##</p>	<p>min. 115 mm</p> <p>L00-FTL51Cxx-06-05-xx-xx-024</p>	<p>In event of synthetic coating: PTFE seal supplied</p> <p>In event of enamel coating: Seal provided by the customer</p>	<p>See nominal pressure of flange, however</p> <p>For ECTFE: Max. 40 bar Max. 120 °C</p> <p>For PFA (Edlon*): Max. 40 bar Max. 150 °C</p> <p>For enamel: Max. 25 bar Max. 150 °C</p>

*) FDA-compliant material in accordance with 21 CFR Part 177.1550/2600

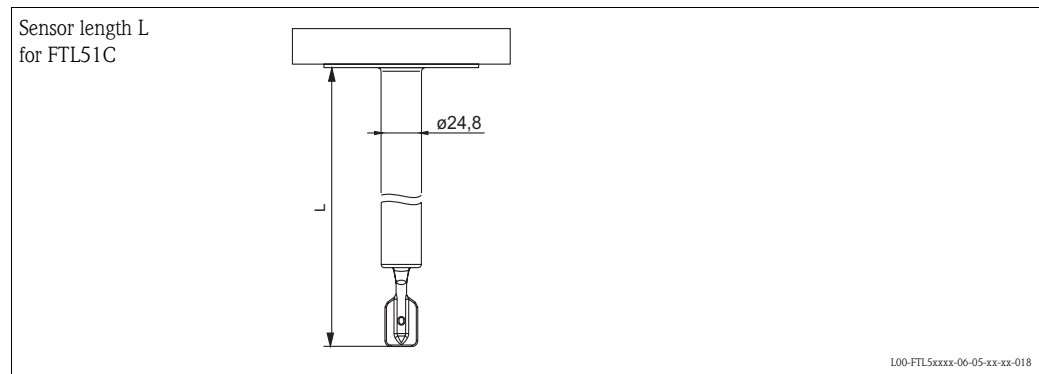

L00-FTL5xxxx-06-05-xx-xx-018

Any length L:
148 mm to 3000 mm (6 in to 115 in) for synthetic coating
148 mm to 1200 mm (6 in to 48 in) for enamel coating



Note!

The switch points of the Liquiphant **M** are at other positions to those of the previous version Liquiphant **II**.

Special length "L II":

115 mm (4.5 in)

With vertical mounting from above the same switchpoint as for the Liquiphant II

FTL360, FTL365, FDL30, FDL35

Weights

See product structure

Material

Material specifications as per AISI and DIN-EN.

Parts in contact with process

- Process connection and extension pipe: 316L (1.4435) coated
- Tuning fork: 316L (1.4435) coated
- Flanges coated:

Layer thickness	ECTFE	PFA (Edlon™)	PFA (RubyRed)	PFA (conductive)	Enamel
Lower limit	0.5 mm	0.45 mm	0.45 mm	0.45 mm	0.4 mm
Upper limit	1.6 mm	1.6 mm	1.6 mm	1.6 mm	0.8 mm
Carrier material	316L (1.4404)	316L (1.4404)	316L (1.4404)	316L (1.4404)	1.0487

Parts with no process contact

- Tuning fork/housing seal: EPDM
- Temperature spacer: 316 L (1.4435)
- Pressure tight feed through: 316L (1.4435)
- Grounding at housing (outside): 304 (1.4301)
- Nameplate at housing (outside): 304 (1.4301)
- Cable glands
 - Housing F13, F15, F16, F17: polyamide (PA)
With B or C approval (→ 31 ordering information): nickel-plated brass
 - Housing F27: 316L
 - Housing T13: nickel-plated brass
- Polyester housing F16: PBT-FR with PBT-FR cover or with PA12 transparent cover
 - Cover seal: EPDM
 - Nameplate glued: polyester film (PET)
 - Pressure compensation filter: PBT-GF20
- Stainless steel housing F15: 316L (1.4404)
 - Cover seal: silicone
 - Safety claw: 304 (1.4301)
 - Pressure compensation filter: PBT-GF20, PA
- Aluminum housing F17/F13: EN-AC-AISi10Mg, plastic-coated
 - Cover seal: EPDM
 - Safety claw: nickel-plated brass
 - Pressure compensation filter: silicone
- Stainless steel housing F27: 316L (1.4435)
 - Cover seal: FVMQ (optional: EPDM seal available as spare part)
 - Safety claw: 316L (1.4435)
- Aluminum housing T13: EN-AC-AISi10Mg, plastic-coated
 - Cover seal: EPDM
 - Safety claw: nickel-plated brass

Process connections

- Flanges made of 316L (1.4404) - synthetic coating; flanges made of 1.0487 (ASTMA 529) - enamel coating
- Flanges to EN/DIN from DN 25, for standards see "Product structure," to ANSI B16.5 from 1", to JIS B 2238 (RF) from DN 50

Human interface

Electronic inserts

With FEL51, FEL52, FEL54, FEL55:
2 switches for safety mode and density change,
green LED to indicate operational status,

red LED to indicate the switching status,
flashes in the event of corrosion damage on sensor
or if the electronics are defective

With FEL56:
2 switches for safety mode and density change,
green LED flashes to indicate operational status,

red LED to indicate the switching status,
flashes in the event of corrosion damage on sensor
or if the electronics are defective

With FEL57:
2 switches for density change and
cyclical checking,
green LED to indicate operational status,
yellow LED to indicate the covered status,
flashes in the event of corrosion damage on sensor
or if the electronics are defective

With FEL58:
2 switches for safety mode and density change,
green LED flashes quickly to indicate operational status,

flashes slowly in the event of corrosion damage on sensor
or if the electronics are defective

yellow LED to indicate the switching status,
Test key – breaks the cable connection

With FEL50A:

- 8 switches for configuring the device address
- green LED to indicate operational status,
pulsing to indicate communication;
- yellow LED to indicate the switching status,
flashes in the event of corrosion damage on sensor
or if the electronics are defective

With FEL50D:

- yellow LED: to indicate the validation of the measurement
- green LED: to indicate the operational status
- red LED: to indicate faults

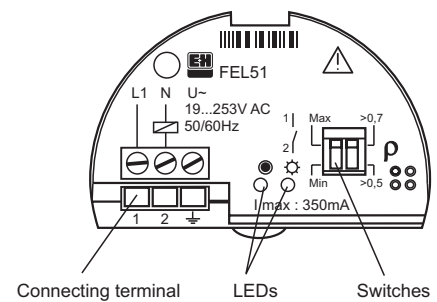

L00-FTL5xxxx-03-05-xx-en-001



L00-FTL5xxxx-03-05-xx-xx-013

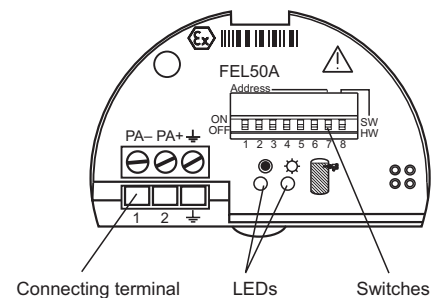

L00-FTL5xxxx-03-05-xx-en-002

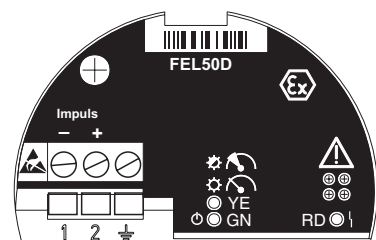

TL328Fxx004

Operating concept

Onsite configuration

Certificates and approvals

Certificates

See product structure

Combinations of coatings, housings and electronic inserts

Based on the various certificates, permissible combinations of coatings, housings * and electronic inserts are given in the following table.

*) Abbreviations: Polyester = PBT, steel 1.4301/1.4435 = St., aluminum = Alu
Aluminum housing with separate connection compartment = Alu/sep.

Coating: ECTFE, PFA, enamel			
	Certificate, applications	Housing	Electronic inserts
A	Without any special certificate (for non-hazardous area)	PBT, St., Alu, Alu/sep.	FEL51/52/54, FEL55/56/57/58/50A/50D
D	Overfill protection to WHG (Germany)	PBT, St., Alu, Alu/sep.	FEL51/52/54, FEL55/56/57/58/50A
R	FM, NI, Cl. I, Div. 2, Gr. A-D	St., Alu, Alu/sep. with NPT cable entry	FEL51/52/54, FEL55/56/57/58/50D
		PBT with NPT cable entry	FEL51/52, FEL55/56/57/58/50D
U	CSA, General Purpose	St., Alu, Alu/sep. with NPT cable entry	FEL51/52/54, FEL55/56/57/58/50D***
		PBT with NPT cable entry	FEL51/52, FEL55/56/57/58/50D***
Y	Other certificate (for non-hazardous area)	PBT, St., Alu, Alu/sep.	FEL51/52/54, FEL55/56/57/58/50A/50D
Coating: enamel or PFA (conductive)			
	Certificate, applications	Housing	Electronic inserts
B	ATEX II 3G EEx nC IIC T6, WHG	PBT, St., Alu, Alu/sep.	FEL54
	ATEX II 3G EEx nC IIC T6, WHG ATEX II 3D T85°C, WHG	St., Alu, Alu/sep.	FEL54
C	ATEX II 3G EEx nA IIC T6, WHG	PBT, St., Alu, Alu/sep.	FEL51/52/54, FEL55/56/57/58/50A/ 50D***
	ATEX II 3G EEx nA IIC T6, WHG ATEX II 3D T85°C, WHG	St., Alu, Alu/sep.	FEL51/52/54, FEL55/56/57/58/50A/ 50D***
E	ATEX II 1/2 G, EEx de IIC T6, WHG	Alu/sep.	FEL51/52/54, FEL55/56/57/58/50A/50D
F	ATEX II 1/2 G, EEx ia IIC T6, WHG	PBT, St., Alu, Alu/sep.	FEL55/56/57/58/50A/50D
	ATEX II 1/2 G, EEx ia IIC T6, WHG ATEX II 1/2 D, T80°C	St., Alu, Alu/sep.	FEL51/52/54, FEL55/56/57/58/50A/50D
L	ATEX II 1/2 G, EEx d IIC T6, WHG	Alu	FEL51/52/54, FEL55/56/57/58/50A/50D
P	FM, IS, Cl. I, II, III, Div. 1, Gr. A-G	PBT, St., Alu, Alu/sep. with NPT cable entry	FEL55/56/57/58/50D/ 50D***
Q	FM, XP, Cl. I, II, III, Div. 1, Gr. A-G	Alu with NPT cable entry	FEL51/52/54, FEL55/56/57/58/50D
S	CSA, IS, Cl. I, II, III, Div. 1, Gr. A-G	PBT, St., Alu, Alu/sep. with NPT cable entry	FEL55/56/57/58/50D/ 50D***
T	CSA, XP, Cl. I, II, III, Div. 1, Gr. A-G	Alu with NPT cable entry	FEL51/52/54, FEL55/56/57/58/50D/ 50D***
Coating: ECTFE, PFA (non-conductive)			

Certificate, applications		Housing	Electronic inserts
1	ATEX II 1/2 G, EEx ia IIB T6, WHG	PBT, St., Alu, Alu/sep.	FEL55/56/57/58/50A/50D
2	ATEX II 1/2 G, EEx d IIB T6, WHG	Alu	FEL51/52/54, FEL55/56/57/58/50A/50D
3	ATEX II 1/2 G, EEx de IIB T6, WHG	Alu/sep.	FEL51/52/54, FEL55/56/57/58/50A/50D
4	ATEX II 1/2 G, EEx ia IIC** T6, WHG	PBT, St., Alu, Alu/sep.	FEL55/56/57/58/50A/50D
5	ATEX II 1/2 G, EEx d IIC** T6, WHG	Alu	FEL51/52/54, FEL55/56/57/58/50A/50D
6	ATEX II 1/2 G, EEx de IIC** T6, WHG	Alu/sep.	FEL51/52/54, FEL55/56/57/58/50A/50D
** With instruction: "Avoid electrostatic charge" *** In preparation!			

Ordering information

Liquiphant M FTL51C product structure

Design							<i>Basic weight</i>
FTL51C	With extension pipe						0.6 kg
10	Approval:						
A	Non-hazardous area						
B	ATEX/NEPSI II 3 G	EEx nC II T6			Overfill protection to WHG (Germany)		
	ATEX/NEPSI II 3 D	T 85 °C*					
C	ATEX/NEPSI II 3 G	EEx nA II T6			Overfill protection to WHG (Germany)		
	ATEX/NEPSI II 3 D	T 85 °C*					
D	Non-hazardous area				Overfill protection to WHG (Germany)		
E	ATEX II 1/2 G	EEx de IIC T6			Overfill protection to WHG (Germany)		
F	ATEX II 1/2 G	EEx ia IIC T6			Overfill protection to WHG (Germany)		
	ATEX II 1/2 D	T 80 °C*					
L	ATEX II 1/2 G	EEx d IIC T6			Overfill protection to WHG (Germany)		
M	NEPSI		Ex ia IIC T6				
N	NEPSI		Ex d IIC T6				
P	FM	IS, Class I, II, III		Division 1, Group A–G			
Q	FM	XP, Class I, II, III		Division 1, Group B–G, for E5 housing Group A–G			
R	FM	NI, Class I		Division 2, Group A–D			
S	CSA	IS, Class I, II, III		Division 1, Group A–G			
T	CSA	XP, Class I, II, III		Division 1, Group A–G			
U	CSA	General Purpose					
V	TIIS	Ex ia IIC T3					
W	TIIS	Ex d IIB T3					
X	TIIS	Ex ia IIC T6					
Y	Special version						
1	ATEX II 1/2 G	EEx ia IIB T6			Overfill protection to WHG (Germany)		
2	ATEX II 1/2 G	EEx d IIB T6			Overfill protection to WHG (Germany)		
3	ATEX II 1/2 G	EEx de IIB T6			Overfill protection to WHG (Germany)		
4	ATEX II 1/2 G	EEx ia IIC T6			Overfill protection to WHG (Germany)		
	Observe safety instructions (XA) (electrostatic charge)!						
5	ATEX II 1/2 G	EEx d IIC T6			Overfill protection to WHG (Germany)		
	Observe safety instructions (XA) (electrostatic charge)!						
6	ATEX II 1/2 G	EEx de IIC T6			Overfill protection to WHG (Germany)		
	Observe safety instructions (XA) (electrostatic charge)!						
7	TIIS	Ex d IIC T3					
8	TIIS	Ex d IIC T6					
	*) Not for PBT						
20	Process connection:						<i>Additional weight</i>
ACK	1½"	150 lbs	ECTFE	> 316/316L	Flange ANSI B16.5	1.5 kg	
ACL	1½"	150 lbs	PFA (Edlon™)	> 316/316L	Flange ANSI B16.5	1.5 kg	
ACM	1½"	150 lbs	PFA (RubyRed)	> 316/316L	Flange ANSI B16.5	1.5 kg	
ACN	1½"	150 lbs	PFA (conductive)	> 316/316L	Flange ANSI B16.5	1.5 kg	
AEK	2"	150 lbs	ECTFE	> 316/316L	Flange ANSI B16.5	2.4 kg	
AEL	2"	150 lbs	PFA (Edlon™)	> 316/316L	Flange ANSI B16.5	2.4 kg	
AEM	2"	150 lbs	PFA (RubyRed)	> 316/316L	Flange ANSI B16.5	2.4 kg	
AEN	2"	150 lbs	PFA (conductive)	> 316/316L	Flange ANSI B16.5	2.4 kg	
AES	2"	150 lbs	Enamel	> 316/316L	Flange ANSI B16.5	2.4 kg	
AFK	2"	300 lbs	ECTFE	> 316/316L	Flange ANSI B16.5	3.2 kg	
AFL	2"	300 lbs	PFA (Edlon™)	> 316/316L	Flange ANSI B16.5	3.2 kg	
AFM	2"	300 lbs	PFA (RubyRed)	> 316/316L	Flange ANSI B16.5	3.2 kg	
AFN	2"	300 lbs	PFA (conductive)	> 316/316L	Flange ANSI B16.5	3.2 kg	
AFS	2"	300 lbs	Enamel	> 316/316L	Flange ANSI B16.5	3.2 kg	
ALK	3"	150 lbs	ECTFE	> 316/316L	Flange ANSI B16.5	4.9 kg	
ALL	3"	150 lbs	PFA (Edlon™)	> 316/316L	Flange ANSI B16.5	4.9 kg	
ALM	3"	150 lbs	PFA (RubyRed)	> 316/316L	Flange ANSI B16.5	4.9 kg	
ALN	3"	150 lbs	PFA (conductive)	> 316/316L	Flange ANSI B16.5	4.9 kg	
APK	4"	150 lbs	ECTFE	> 316/316L	Flange ANSI B16.5	7.0 kg	
APL	4"	150 lbs	PFA (Edlon™)	> 316/316L	Flange ANSI B16.5	7.0 kg	
APM	4"	150 lbs	PFA (RubyRed)	> 316/316L	Flange ANSI B16.5	7.0 kg	
APN	4"	150 lbs	PFA (conductive)	> 316/316L	Flange ANSI B16.5	7.0 kg	
A8K	1"	150 lbs	ECTFE	> 316/316L	Flange ANSI B16.5	1.0 kg	
A8L	1"	150 lbs	PFA (Edlon™)	> 316/316L	Flange ANSI B16.5	1.0 kg	
A8M	1"	150 lbs	PFA (RubyRed)	> 316/316L	Flange ANSI B16.5	1.0 kg	

20	Process connection:						Additional weight
A8N	1"	150 lbs	PFA (conductive)	> 316/316L	Flange ANSI B16.5	1.0 kg	
BBK	DN32	PN25/40	ECTFE	>316L	Flange EN 1092-1 (DIN 2527)	2.0 kg	
BBL	DN32	PN25/40	PFA (Edlon™)	>316L	Flange EN 1092-1 (DIN 2527)	2.0 kg	
BBM	DN32	PN25/40	PFA (RubyRed)	>316L	Flange EN 1092-1 (DIN 2527)	2.0 kg	
BBN	DN32	PN25/40	PFA (conductive)	>316L	Flange EN 1092-1 (DIN 2527)	2.0 kg	
BDK	DN40	PN25/40	ECTFE	>316L	Flange EN 1092-1 (DIN 2527)	2.4 kg	
BDL	DN40	PN25/40	PFA (Edlon™)	>316L	Flange EN 1092-1 (DIN 2527)	2.4 kg	
BDM	DN40	PN25/40	PFA (RubyRed)	>316L	Flange EN 1092-1 (DIN 2527)	2.4 kg	
BDN	DN40	PN25/40	PFA (conductive)	>316L	Flange EN 1092-1 (DIN 2527)	2.4 kg	
BEK	DN50	PN6	ECTFE	>316L	Flange EN 1092-1 (DIN 2527)	1.6 kg	
BEL	DN50	PN6	PFA (Edlon™)	>316L	Flange EN 1092-1 (DIN 2527)	1.6 kg	
BEM	DN50	PN6	PFA (RubyRed)	>316L	Flange EN 1092-1 (DIN 2527)	1.6 kg	
BEN	DN50	PN6	PFA (conductive)	>316L	Flange EN 1092-1 (DIN 2527)	1.6 kg	
BGK	DN50	PN25/40	ECTFE	>316L	Flange EN 1092-1 (DIN 2527)	3.2 kg	
BGL	DN50	PN25/40	PFA (Edlon™)	>316L	Flange EN 1092-1 (DIN 2527)	3.2 kg	
BGM	DN50	PN25/40	PFA (RubyRed)	>316L	Flange EN 1092-1 (DIN 2527)	3.2 kg	
BGN	DN50	PN25/40	PFA (conductive)	>316L	Flange EN 1092-1 (DIN 2527)	3.2 kg	
BNK	DN80	PN25/40	ECTFE	>316L	Flange EN 1092-1 (DIN 2527)	5.9 kg	
BNL	DN80	PN25/40	PFA (Edlon™)	>316L	Flange EN 1092-1 (DIN 2527)	5.9 kg	
BNM	DN80	PN25/40	PFA (RubyRed)	>316L	Flange EN 1092-1 (DIN 2527)	5.9 kg	
BNN	DN80	PN25/40	PFA (conductive)	>316L	Flange EN 1092-1 (DIN 2527)	5.9 kg	
BOK	DN100	PN10/16	ECTFE	>316L	Flange EN 1092-1 (DIN 2527)	5.6 kg	
BOL	DN100	PN10/16	PFA (Edlon™)	>316L	Flange EN 1092-1 (DIN 2527)	5.6 kg	
BOM	DN100	PN10/16	PFA (RubyRed)	>316L	Flange EN 1092-1 (DIN 2527)	5.6 kg	
BON	DN100	PN10/16	PFA (conductive)	>316L	Flange EN 1092-1 (DIN 2527)	5.6 kg	
B8K	DN25	PN25/40	ECTFE	>316L	Flange EN 1092-1 (DIN 2527)	1.4 kg	
B8L	DN25	PN25/40	PFA (Edlon™)	>316L	Flange EN 1092-1 (DIN 2527)	1.4 kg	
B8M	DN25	PN25/40	PFA (RubyRed)	>316L	Flange EN 1092-1 (DIN 2527)	1.4 kg	
B8N	DN25	PN25/40	PFA (conductive)	>316L	Flange EN 1092-1 (DIN 2527)	1.4 kg	
CGS	DN50	PN25/40	Enamel	>1.0487	Flange EN 1092-1 (DIN 2527)	3.2 kg	
CNS	DN80	PN25/40	Enamel	>1.0487	Flange EN 1092-1 (DIN 2527)	5.9 kg	
KEK	10 K 50		ECTFE	>316L	Flange JIS B2238	1.7 kg	
KEL	10 K 50		PFA (Edlon™)	>316L	Flange JIS B2238	1.7 kg	
KEM	10 K 50		PFA (RubyRed)	>316L	Flange JIS B2238	1.7 kg	
KEN	10 K 50		PFA (conductive)	>316L	Flange JIS B2238	1.7 kg	
YY9	Special version						

30	Probe length; Type:			
BK mm		ECTFE	0.9 kg/m
BL mm		PFA (Edlon™)	0.9 kg/m
BM mm		PFA (RubyRed)	0.9 kg/m
BN mm		PFA (conductive)	0.9 kg/m
BS mm		Enamel	0.9 kg/m
CK inch		ECTFE	2.3 kg/100 in
CL inch		PFA (Edlon™)	2.3 kg/100 in
CM inch		PFA (RubyRed)	2.3 kg/100 in
CN inch		PFA (conductive)	2.3 kg/100 in
CS inch		Enamel	2.3 kg/100 in
DK	Length: type II**		ECTFE	
DL	Length: type II**		PFA (Edlon™)	
DM	Length: type II**		PFA (RubyRed)	
DN	Length: type II**		PFA (conductive)	
DS	Length: type II**		Enamel	
YY	Special version			
**) Replacing devices: when vertically mounting a Liquiphant M FTL51C with length II, the switch point is at the same height as for a Liquiphant II FTL360, FTL365, FDL30, FDL35				

40	Electronics; output:		
A	FEL50A	PROFIBUS PA	
D	FEL50D	Density/concentration	
1	FEL51	2-wire 19 to 253 V AC	
2	FEL52	3-wire PNP 10 to 55 V DC	
4	FEL54	Relay DPDT 19 to 253 V AC, 19 to 55 V DC	
5	FEL55	8/16 mA, 11 to 36 V DC	
6	FEL56	NAMUR (L-H signal)	
7	FEL57	2-wire PFM	

40									Electronics; output:
					8	FEL58	NAMUR + test keys (H-L signal)		
					9	Special version			
50									Housing; cable entry:
					E1*	F27 316L	NEMA6P;	Thread NPT 3/4	
					E4	F16 Polyester	NEMA4X;	Thread NPT 1/2	
					E5	F13/F17 Alu	NEMA4X;	Thread NPT 3/4	0.5 kg
					E6	F15 316L	NEMA4X;	Thread NPT 1/2	0.1 kg
					E7	T13 Alu	coated, IP66;	Thread NPT 3/4	0.9 kg
						Separate connection compartment			
					F1*	F27 316L	IP68	Thread G1/2	
					F4	F16 Polyester	IP66;	Thread G 1/2	
					F5	F13/F17 Alu	IP66;	Thread G 1/2	0.5 kg
					F6	F15 316L	IP66;	Thread G 1/2	0.1 kg
					F7	T13 Alu	coated, IP66;	Thread G 1/2	0.9 kg
						Separate connection compartment			
					G1*	F27 316L	IP68;	M20 threaded joint	
					G4	F16 Polyester	IP66;	M20 threaded joint	
					G5	F13/F17 Alu	IP66;	M20 threaded joint (EEx d > M20 thread)	0.5 kg
					G6	F15 316L	IP66;	M20 threaded joint	0.1 kg
					G7	T13 Alu	coated, IP66;	M20 threaded joint (EEx d > M20 thread)	0.9 kg
						Separate connection compartment			
					N4	F16 Polyester	IP66;	M12 connector	
					N5	F13/F17 Alu	IP66;	M12 connector	
					N6	F15 316L	IP66;	M12 connector	
					Y9	Special version			
						* F27 housing in preparation.			
60									Additional options 1:
					A	Not selected			
					K	Special adjustment, density H20			
					L	Special adjustment, density H20, EN10204-3.1			
					S	GL/ABS marine approval (max. 1600 mm)			
					Y	Special version			
70									Additional options 2:
					A	Not selected			
					B	Temperature spacer			
					C	2nd line of defence > pressure tight feed-through			
					Y	Special version			
FTL51C -									Complete product designation
									Note! The basic weight includes the compact sensor, electronic insert and polyester housing

Accessories

Transparent cover

For polyester housing F16
 Material: PA 12
 Weight: 0.04 kg
 Order number: 943461-0001

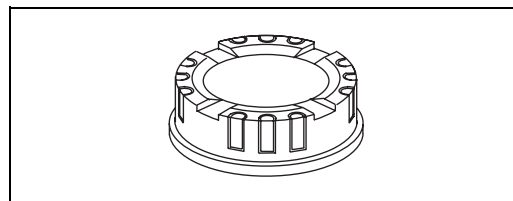

L00-FTL5xxx-03-05-xx-xx-016

Cover with sight glass

For stainless steel housing F15
 Material: AISI 316L
 Weight: 0.16 kg
 – With glass sight glass
 Order number: 943301-1000
 – With PC sight glass
 Order number: 52001403
 (Not for CSA, General Purpose)

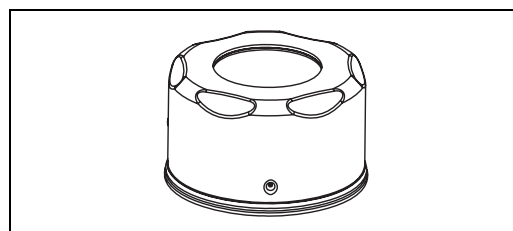

L00-FTL5xxx-03-05-xx-xx-017

Documentation



Note!
 You can find supplementary documentation on the product pages at www.endress.com

Operating Instructions

Electronic insert FEL50A for Liquiphant M/S
 PROFIBUS PA
 BA141F/00/en

Liquiphant M Density,
 Density Computer FML621
 BA335F/00/en

Liquiphant M FTL51C
 KA162F/00/a6

Liquiphant M FTL51C-##### 7 ##
 KA165F/00/a6

Liquiphant M Density FTL50, FTL51
 Electronic insert: FEL50D
 KA284F/00/a6

Liquiphant M Density FTL50H, FTL51H
 Electronic insert: FEL50D
 KA285F/00/a6

Liquiphant M Density FTL51C
 Electronic insert: FEL50D
 KA286F/00/a6

Technical Information

Nivotester FTL370/372, switching units in Racksyst design
 for Liquiphant M with electronic insert FEL57
 TI198F/00/en

Nivotester FTL320, switching unit in Minipac design
 for Liquiphant M with electronic insert FEL57
 TI203F/00/en

General instructions for electromagnetic compatibility
 (Test procedure, installation recommendation)
 TI241F/00/en

Liquiphant M FTL50/51(H), for process temperatures up to 150 °C

TI328F/00/en

Isolating amplifier FTL325P,
1 or 3-channel switching units for top-hat rail mounting
for Liquiphant M/S with electronic insert FEL57
TI350F/00/en

Isolating amplifier FTL325N,
1 or 3-channel switching units for top-hat rail mounting
For Liquiphant M/S with electronic insert FEL56, FEL58
TI353F/00/en

Liquiphant S FTL70/71, for medium temperatures up to 280 °C
TI354F/00/en

Isolating amplifier FTL375P,
1 to 3-channel switching units for top-hat rail mounting
for Liquiphant M/S with electronic insert FEL57
TI360F/00/en

Isolating amplifier FTL375N,
1 to 3-channel switching units for top-hat rail mounting
For Liquiphant M/S with electronic insert FEL56, FEL58
TI361F/00/en

Liquiphant M Density,
Density Computer FML621
TI420F/00/en

Functional safety (SIL)

Liquiphant M/S with electronic insert FEL51 (MAX)
SD164F/00/en

Liquiphant M/S with electronic insert FEL51 (MIN)
SD185F/00/en

Liquiphant M/S with electronic insert FEL52 (MAX)
SD163F/00/en

Liquiphant M/S with electronic insert FEL52 (MIN)
SD186F/00/en

Liquiphant M/S with electronic insert FEL54 (MAX)
SD162F/00/en

Liquiphant M/S with electronic insert FEL54 (MIN)
SD187F/00/en

Liquiphant M/S with electronic insert FEL55 (MAX)
SD167F/00/en

Liquiphant M/S with electronic insert FEL55 (MIN)
SD279F/00/en

Liquiphant M/S with electronic insert FEL57 + Nivotester FTL325P (MAX)
SD111F/00/en

Liquiphant M/S with electronic insert FEL57 + Nivotester FTL325P (MIN)
SD231F/00/en

Liquiphant M/S with electronic insert FEL57+ Nivotester FTL375P (MAX)
SD113F/00/en

Liquiphant M/S with electronic insert FEL56 + Nivotester FTL325N (MAX)
SD168F/00/en

Liquiphant M/S with electronic insert FEL56 + Nivotester FTL325N (MIN)
SD188F/00/en

Liquiphant M/S with electronic insert FEL58 + Nivotester FTL325N (MAX)
SD161F/00/en

Liquiphant M/S with electronic insert FEL58 + Nivotester FTL325N (MIN)
SD170F/00/en

Safety Instructions (ATEX)

CE  II 1/2 G, EEx d IIC/B

(KEMA 99 ATEX 1157)
XA031F/00/a3

CE  II 1/2 G, EEx ia/ib IIC/B
(KEMA 99 ATEX 0523)
XA063F/00/a3

CE  II 1 G, EEx ia IIC/B
(KEMA 99 ATEX 5172 X)
XA064F/00/a3

CE  II 1/2 G, EEx de IIC/B
(KEMA 00 ATEX 2035)
XA108F/00/a3

CE  II 3 G, EEx nA/nC II
(EG 01 007-a)
XA182F/00/a3

Safety Instructions (NEPSI)

Ex d IIC/IIB T3-T6 , Ex d IIC T2-T6
(NEPSI GYJ06424)
XA401F/00/B2

Ex ia IIC T2-T6, Ex ia IIB T3-T6
(NEPSI GYJ05556, NEPSI GYJ06464),
XC009F/00/b2

Ex nA II T3-T6, Ex nC/nL IIC T3-T6
(NEPSI GYJ04360, NEPSI GYJ071414)
XC010F/00/b2

Control Drawings

Liquiphant M/S (IS and NI) Current output PFM, NAMUR Entity installation
Class I, Div. 1, 2, Groups A, B, C, D
Class I, Zone 0
Class II, Div. 1, 2, Groups E, F, G
Class III
ZD041F-I/00/EN

Liquiphant M, Liquiphant S (cCSAus / IS)
Class I, Div. 1, Groups A, B, C, D Ex ia IIC T6
Class II, Div. 1, Groups E, F, G
Class III
ZD042F-G/00/EN

Liquiphant M/S (NI), FTL50(H), FTL51(H), FTL51C, FTL70, FTL71
Class I, Div. 2, Groups A, B, C, D
Class II, Div. 2, Groups F, G
Class III
ZD043F-C/00/EN

Liquiphant M, Liquiphant S (cCSAus / XP)
Class I, Groups A, B, C, D
Class II, Groups E, F, G
Class III
ZD240F/00/EN

Liquiphant M/S (IS and NI) PROFIBUS PA, FOUNDATION Fieldbus
Class I, Zone 0, IIC
Class I, Division 1, 2, Groups A, B, C, D
Class II, Division 1, 2, Groups E, F, G
Class III
ZD244F/00/EN

System information

Liquiphant M
SI040F/00/en

Instruments International

Endress+Hauser
Instruments International AG
Kaegenstrasse 2
4153 Reinach
Switzerland

Tel. +41 61 715 81 00
Fax +41 61 715 25 00
www.endress.com
info@ii.endress.com

Endress+Hauser 
People for Process Automation

