

Technical Information

HAW562

Surge arresters



for DIN rail according to EN 60715

Application

Surge arresters are used to weaken residual currents from upstream lightning protection steps and to limit system-induced or system-generated overvoltage surges.

HAW562 units are primarily used in process automation and in measuring and communication technology within the chemicals, pharmaceuticals, water and wastewater sectors as well as in the food industry.

Your benefits

- Increased plant availability as surge arrester is perfectly matched to the electronic components involved in process automation and process measuring technology.
- Application in Ex areas - optionally available with intrinsically safe approvals.
- SIL2 (optional)
- Direct and indirect shield grounding
- Investment intensive measuring instruments protected.
- Vibration and shock tested according to EN 60068-2

Function and system design

Operating principle

The HAW562 surge arrester is used to protect electronic components from being destroyed by overvoltage. It ensures that overvoltage surges which occur in signal cables (e.g. 4 to 20 mA), in communication lines (Field buses) and in power lines are safely passed into the ground.

The functionality of the transmitter or the electronics component to be protected is not affected.

Operation of power supply protection units:

Using the impedance-free connection of the protection unit, interference voltage drops cannot be introduced on the power lines.

Operation of signal cable protection units:

Low and matched disconnection impedance between the individual protection steps within the unit guarantee high compatibility with the system to be protected.

Available versions

For power lines:

- HAW562-AAB to protect power lines in non-Ex areas, voltage range 10-55 V
- HAW562-AAC to protect power lines in non-Ex areas, voltage range 90-230 V

For signal cables and communication lines:

- HAW562-AAA to protect signal cables in non-Ex areas
- HAW562-8DA with Ex ia approval to protect signal cables
- HAW562-AAD to protect communication lines (RS485, Modbus, Profibus DP) in non-Ex areas
- HAW562-AAE protection module for Prosonic FMU90 in non-Ex areas

System construction

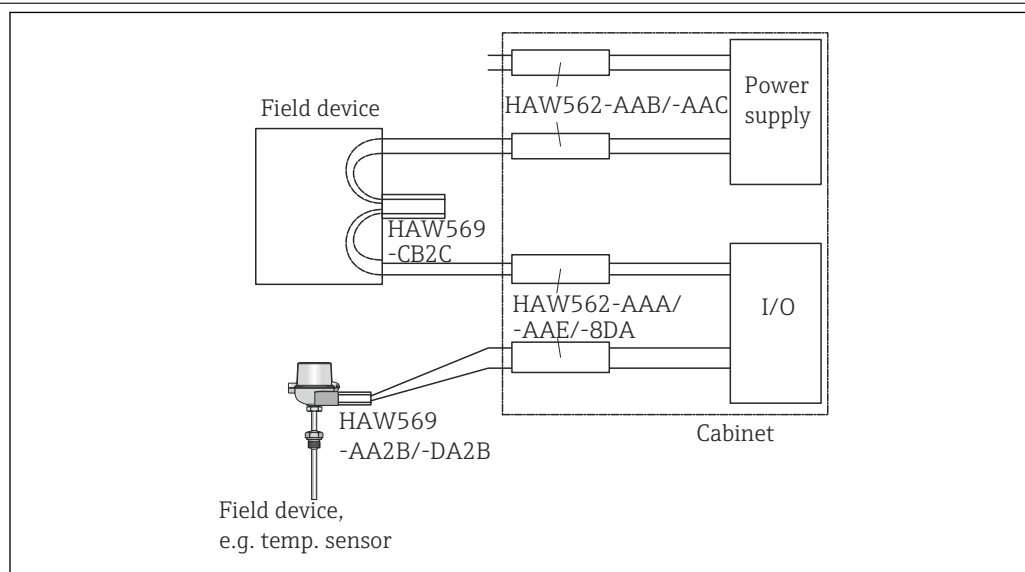

A0015113-EN

1 Overview of system construction, HAW562 and HAW569

Application

Overvoltage protection of various measurement instrumentation seen in the example of a water treatment plant.

Conditions for the installation of surge arresters in a water treatment plant are:

- Lightning protection of plant and buildings
- Lightning protection of the main power supply distribution circuits in accordance with local regulations
- Low impedance foundation grounding
- Linked grounding of all buildings and plant (→ 2, 3)

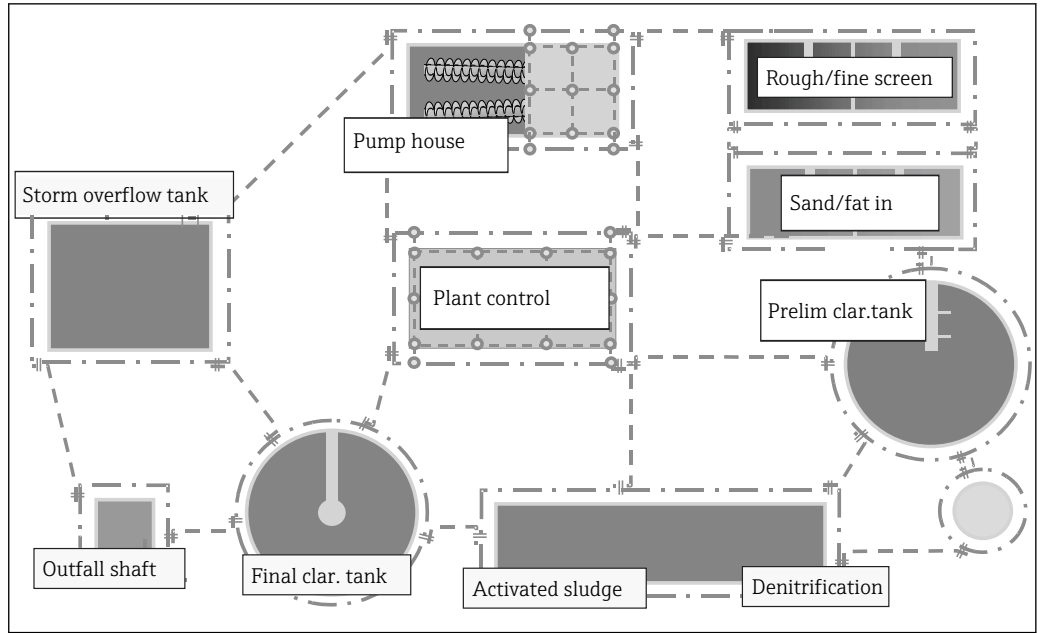

A0015026-EN



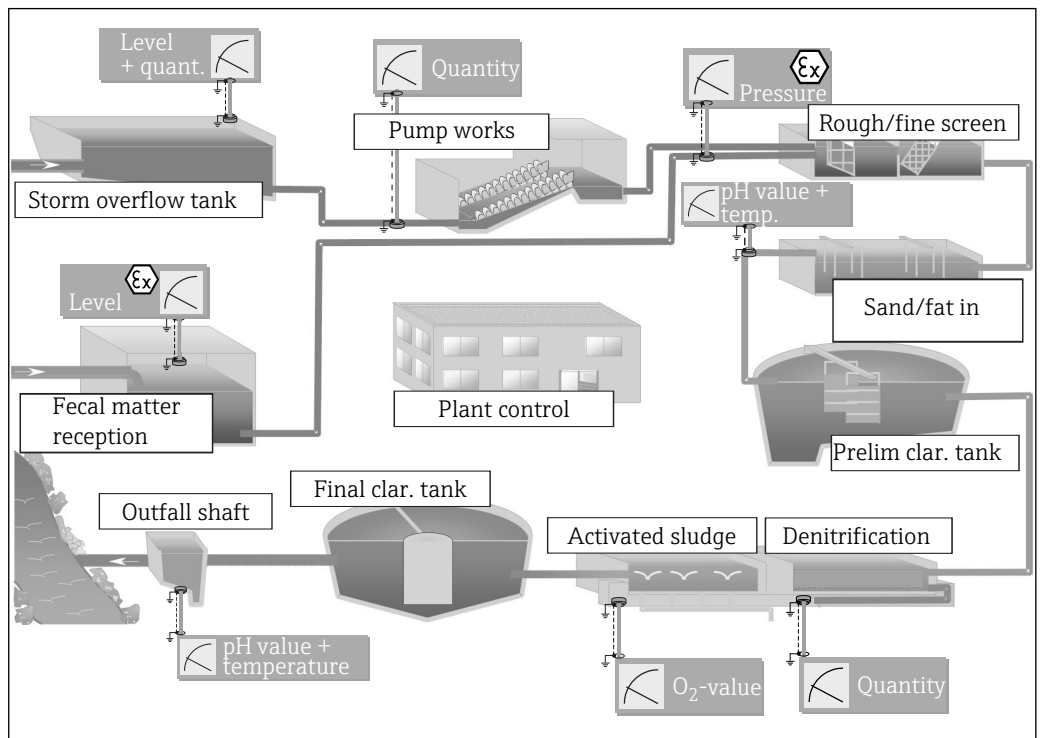





















2 Linked grounding (schematic diagram)



A0015027-EN

3 Water treatment example (schematic diagram)

**Fitting out measuring points
in a water treatment plant**

	Sample measuring point	Measuring point requirements	Connection diagram
Storm overflow tanks Level and overflow quantity	<ul style="list-style-type: none"> ▪ Level measurement: 0/4 to 20 mA ▪ Overflow quantity measurement: 0/4 to 20 mA Prosonic S FMU90 transducer with 2 Prosonic FDU9x sensors	<ul style="list-style-type: none"> ▪ 2 x HAW562-AAA for 0/4 to 20 mA remote signal ▪ 1 x HAW562-AAB or HAW562-AAC for power supply to the transducer ▪ 2 x HAW562-AAE for the sensor signal cable 	Connection diagram 1, (→  4,  5)
Pumping system Quantity	Quantity measurement: 0/4 to 20 mA Prosonic S FMU90 transducer with Prosonic FDU9x level measurement sensors	<ul style="list-style-type: none"> ▪ 1 x HAW562-AAA for 0/4 to 20 mA signals ▪ 1 x HAW562-AAB or HAW562-AAC for power supply to the transducer ▪ 1 x HAW562-AAE for the sensor signal cable 	Connection diagram 2, (→  5,  5)
Pump station	Level measurement Prosonic S FMU90 transducer with Prosonic FDU9x level measurement sensor	<ul style="list-style-type: none"> ▪ 1 x HAW562-AAE for the sensor signal cable Use indirect shield grounding. ▪ 1 x HAW562-AAB or HAW562-AAC for power supply to the transducer 	Connection diagram 3, (→  6,  6)
Sewage inlet Level	Level measurement: Prosonic S FMU90 transducer with Prosonic FDU9x level measurement sensor PROFIBUS DP signal	1 x HAW562-AAD for PROFIBUS DP signal.	Connection diagram 4, (→  7,  6)
Pipe Intrinsically safe pump pressure monitoring 	Pressure measurement: 4 to 20 mA Cerabar S pressure transmitter	1 x HAW562-8DA for 4 to 20 mA remote signal in Ex area.	Connection diagram 5, (→  8,  6)
Inlet prelim. clarification pit pH value + temperature	<ul style="list-style-type: none"> ▪ pH value measurement: 0/4 to 20 mA ▪ Temperature measurement: 0/4 to 20 mA Liquisys M CPM253 transmitter with CYA611 and CPS11 measuring sensors	<ul style="list-style-type: none"> ▪ 2 x HAW562-AAA for 0/4 to 20 mA remote signal ▪ 1 x HAW562-AAB or HAW562-AAC for power supply to the transducer 	Connection diagram 6, (→  9,  7)
Denitrification Recirculation quantity	Flow measurement: 0/4 to 20 mA Promag 50 W flowmeter	<ul style="list-style-type: none"> ▪ 1 x HAW562-AAA for 0/4 to 20 mA remote signal ▪ 1 x HAW562-AAB or HAW562-AAC for power supply to the transducer 	Connection diagram 7, (→  10,  7)
Activation pit Dissolved oxygen	Oxygen content measurement: 0/4 to 20 mA Liquisys M CPM253 transmitter with COS41 measuring sensor	<ul style="list-style-type: none"> ▪ 1 x HAW562-AAA for 0/4 to 20 mA remote signal ▪ 1 x HAW562-AAB or HAW562-AAC for power supply to the transducer 	Connection diagram 2, (→  5,  5) and Connection diagram 7, (→  10,  7)
Outfall pH value and temperature	See inlet prelim. clarification	See inlet prelim. clarification	Connection diagram 1, (→  4,  5) and Connection diagram 6, (→  9,  7)
Other application example: Flow measurement	E.g. Coriolis Promass 84, 83, 80; T-mass, Prosonic 92F or 91w, 93W	1 HAW569-CB2C for power supply and signal cable	Example: Proline Prosonic Flow 91W, Connection diagram 8, (→  11,  7)

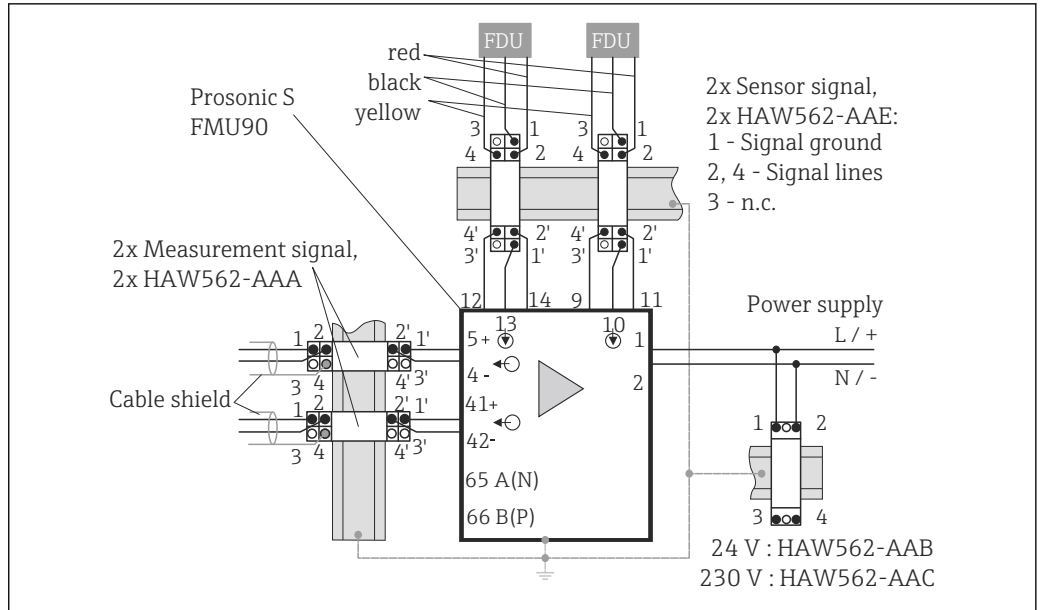

A0015028-EN

4 Connection diagram 1: Level measurement with Prosonic S FMU90 with 2 Prosonic FDU9x level sensors

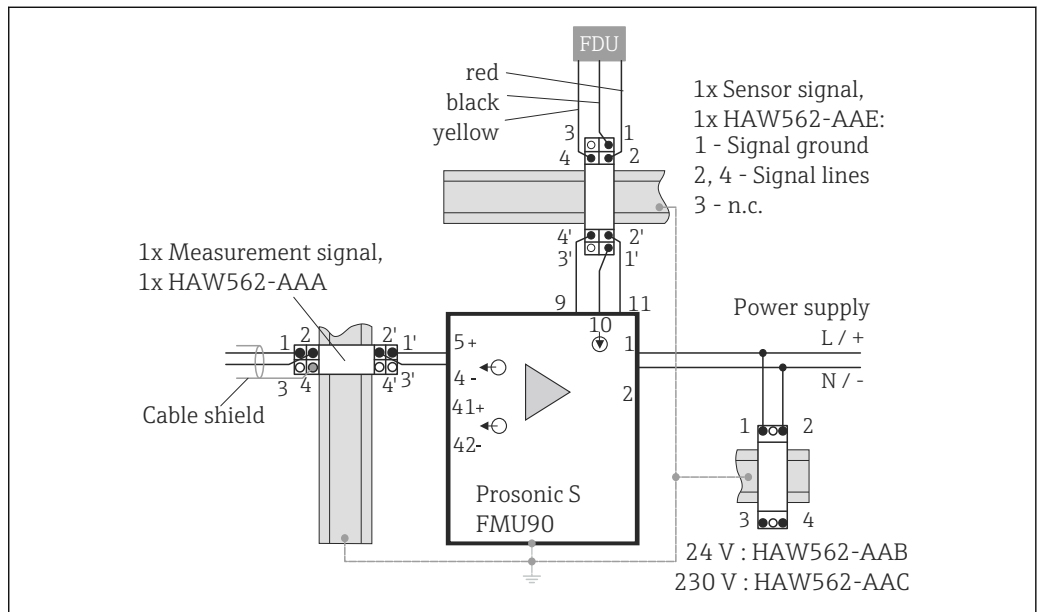

A0015029-EN

5 Connection diagram 2: Level measurement with Prosonic S FMU90 with Prosonic FDU9x level measuring sensor

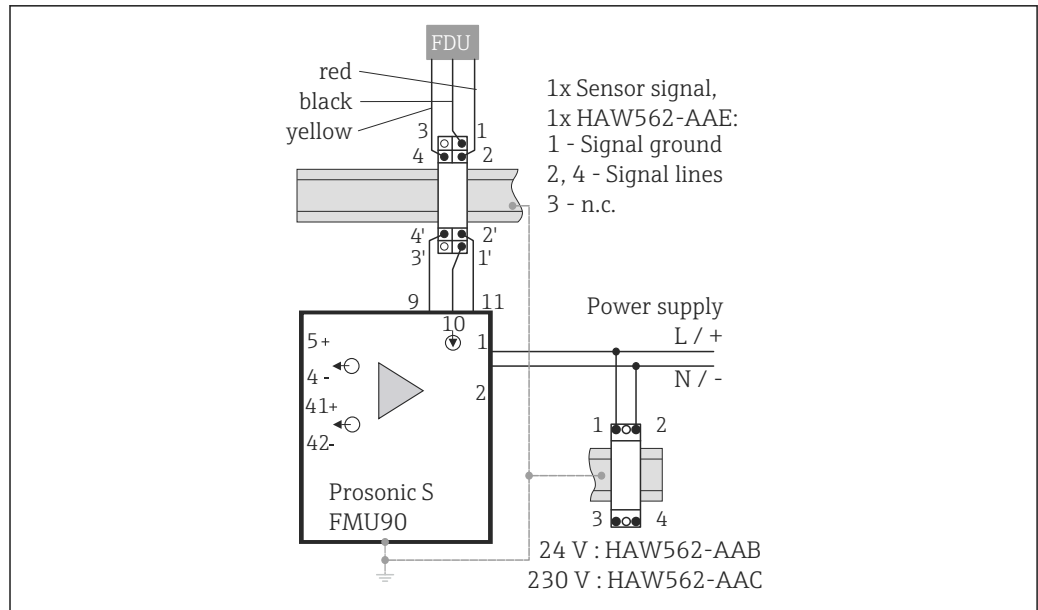

A0015037-EN

6 Connection diagram 3: Level measurement with Prosonic S FMU90 with Prosonic FDU9x level measuring sensor

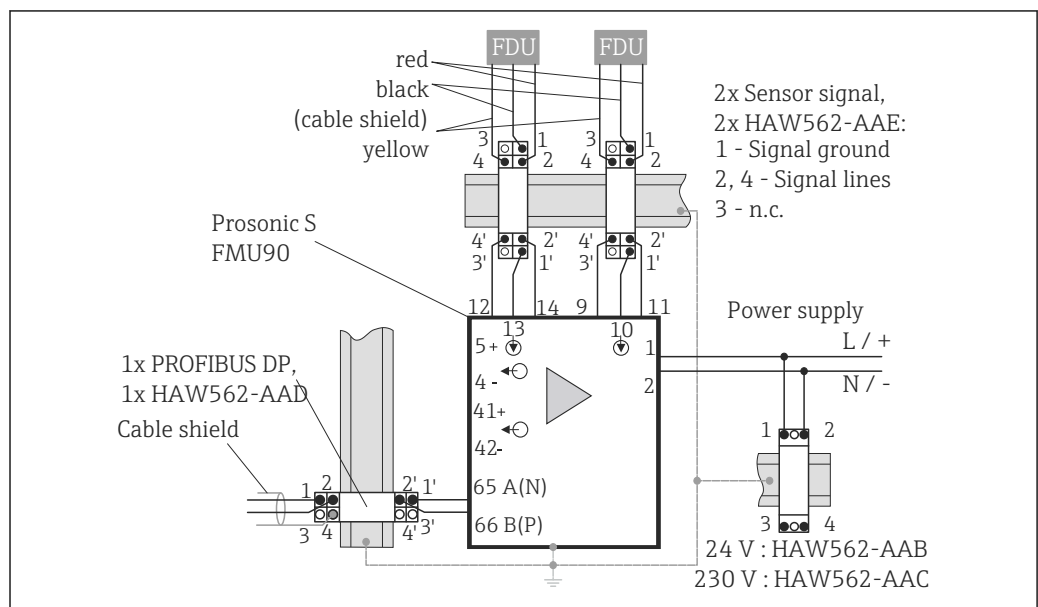

A0015038-EN

7 Connection diagram 4: Level measurement with PROFIBUS DP signal

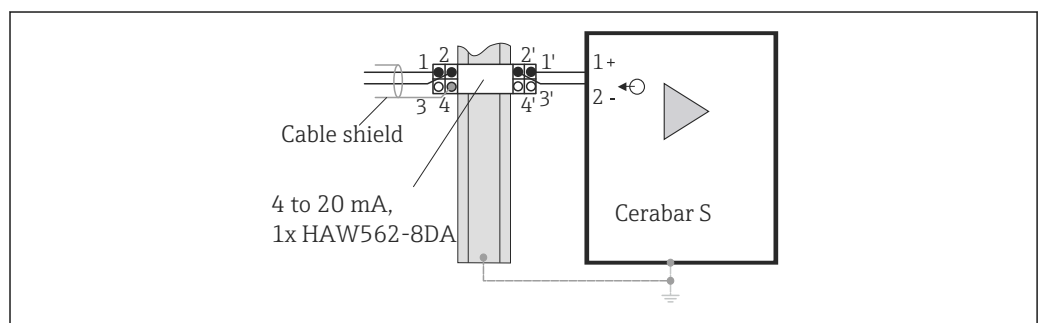

A0015039-EN

8 Connection diagram 5: Pressure measurement with Cerabar S pressure transmitter

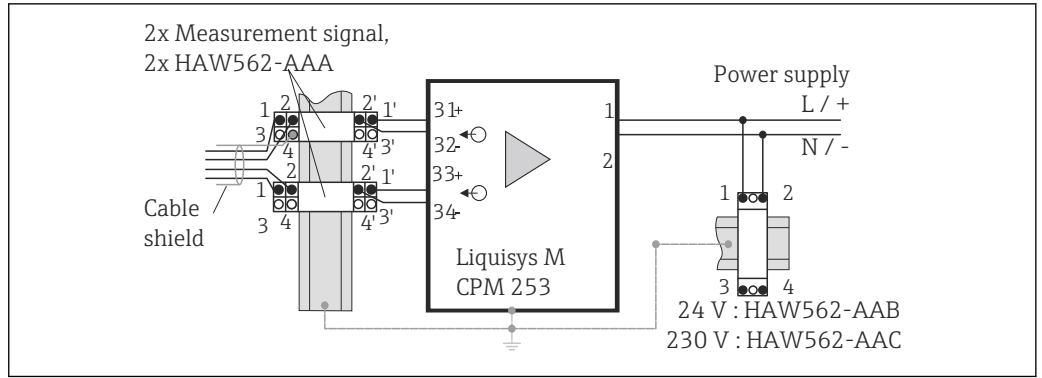

A0015040-EN

9 Connection diagram 6: pH value and temperature measurement with M CPM253 with CYA611 and CPS11 measuring sensors

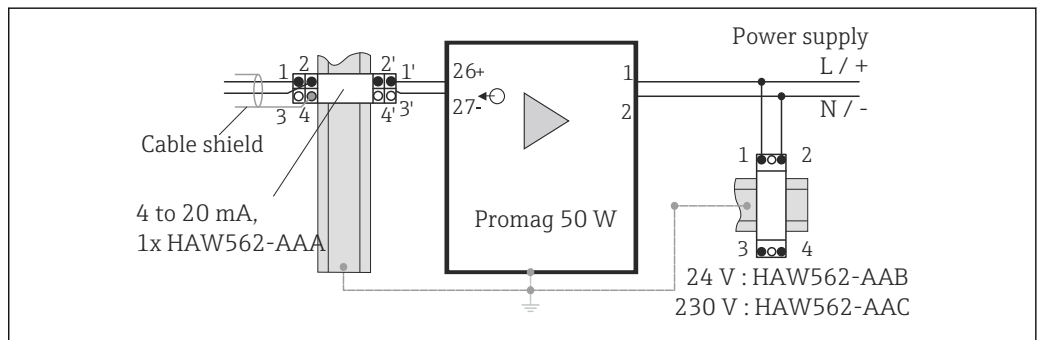

A0015041-EN

10 Connection diagram 7: Flow measurement with Promag 50 W

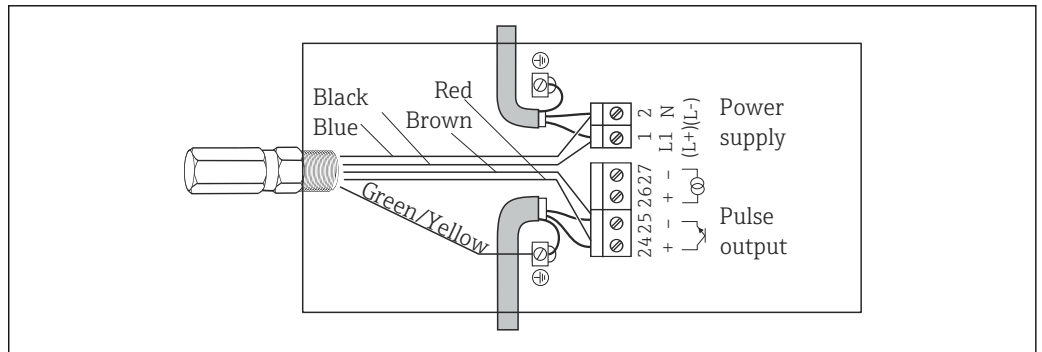

A0015110-EN

11 Connection diagram 8: Flow measurement, e.g. Coriolis Promass 84, 83, 80; T-mass, Prosonic 92F or 91w, 93W

Power supply

Electrical connection

HAW562-AAA, HAW562-AAD, HAW562-8DA

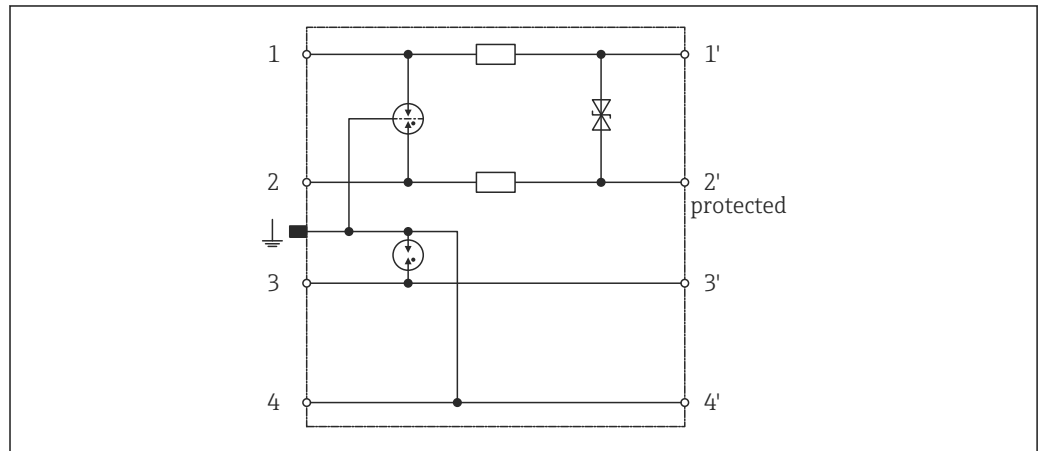

A0015066-EN

12 HAW562-AAA, HAW562-AAD, HAW562-8DA internal circuitry

HAW562-AAB, HAW562-AAC

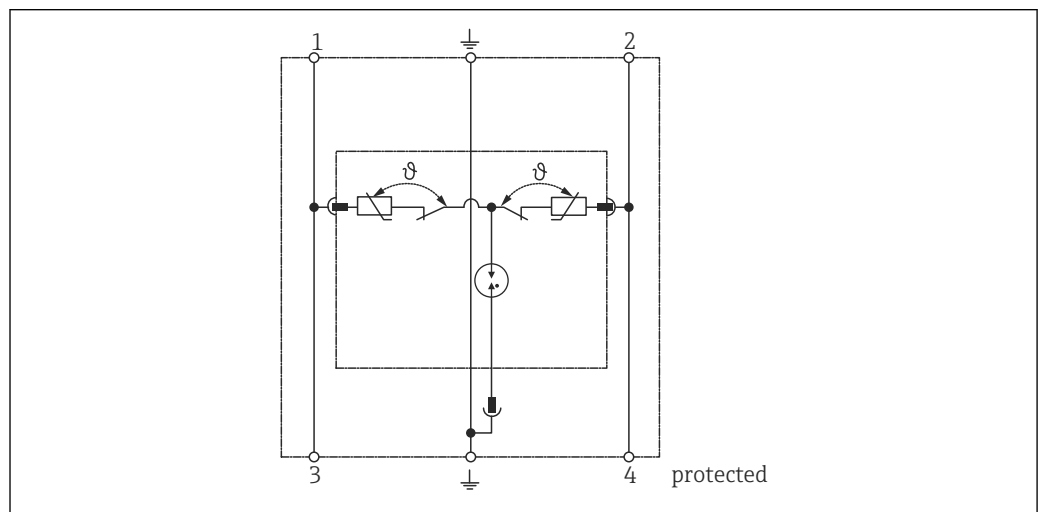

A0015067-EN

13 HAW562-AAB, HAW562-AAC internal circuitry

HAW562-AAE

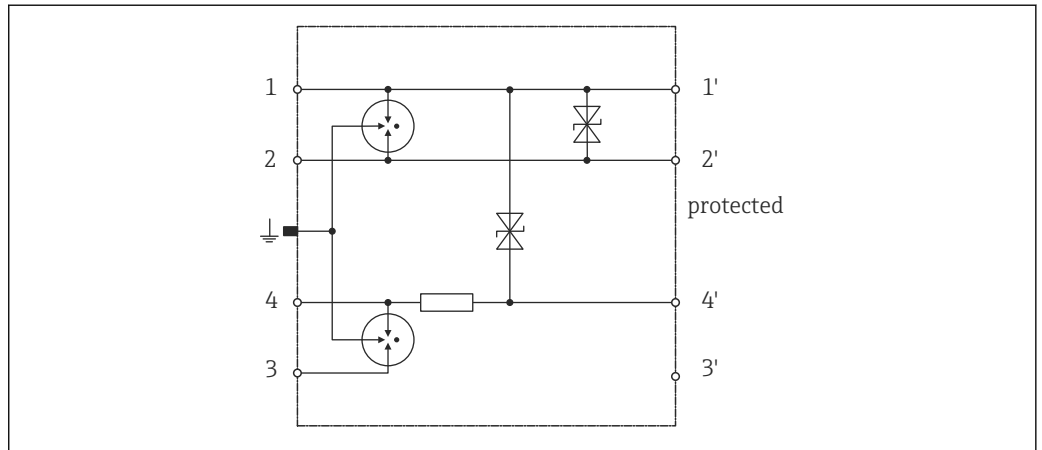

A0015068-EN

14 HAW562-AAE internal circuitry

Connection instructions

Correct installation: HAW562-AAA, -AAD, -AAE, -8DA

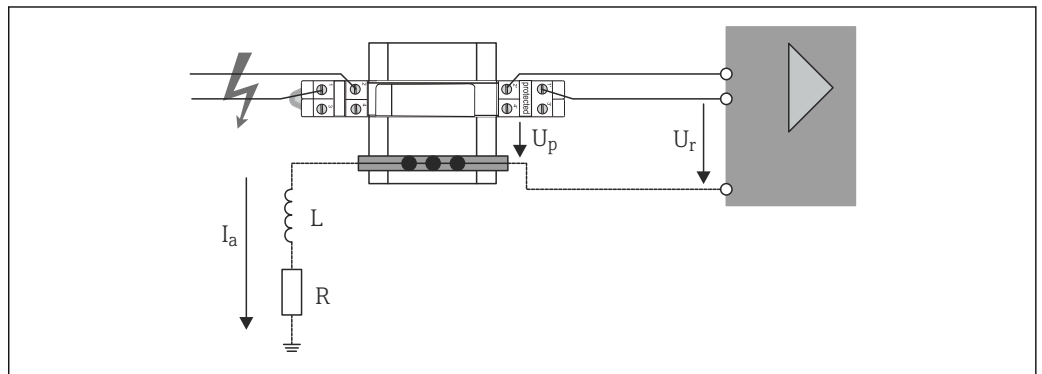

A0015072

15 Correct installation of HAW562-AAA, -AAD, -AAE, -8DA; L and R of the cable have no influence on U_r ; $U_p = U_r$; I_a current transfer

Incorrect installation 1: HAW562-AAA, -AAD, -AAE, -8DA

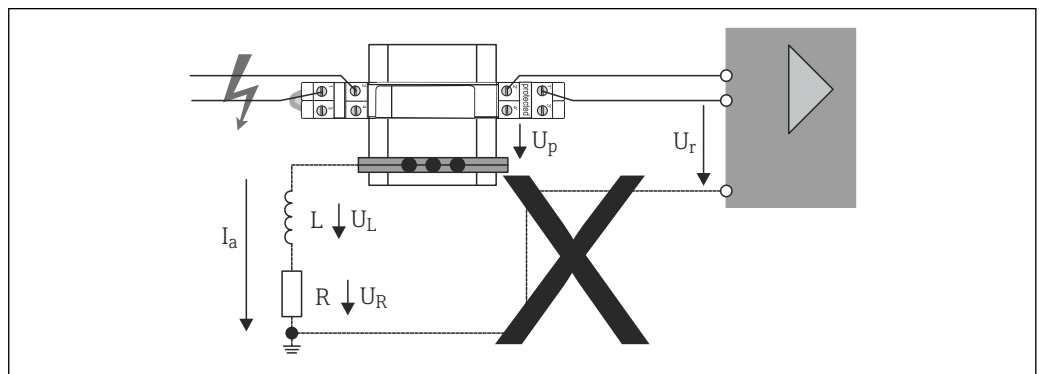

A0015073

16 Incorrect installation 1: HAW562-AAA, -AAD, -AAE, -8DA; L and R of the cable worsen U_r ; $U_r = U_p + U_L + U_R$; I_a current transfer

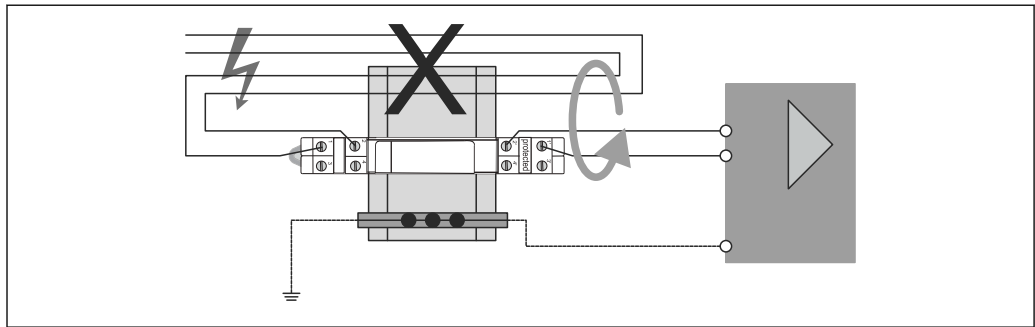
Incorrect installation 2: HAW562-AAA, -AAD, -AAE, -8DA

A0015074

- 17 *Incorrect installation 2: HAW562-AAA, -AAD, -AAE, -8DA; Due to incorrect cable installation, interference is transmitted from unprotected cables to the protected cables.*

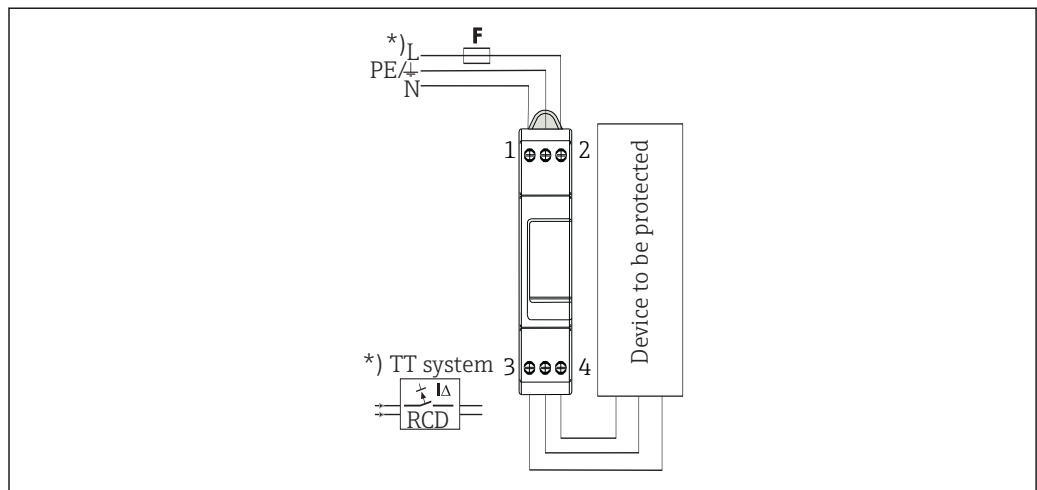
Correct installation 1: Series wiring HAW562-AAB, -AAC

A0015081-EN

- 18 *Series wiring HAW562-AAB, HAW562-AAC*

A ground fault circuit interrupter must be provided in the TT system.

The back-up fuse must be $F \leq 25$ A gG if serial wiring is selected. Parallel wiring must be selected for back-up fuses $F > 25$ A.

Correct installation 2: Parallel wiring HAW562-AAB, -AAC

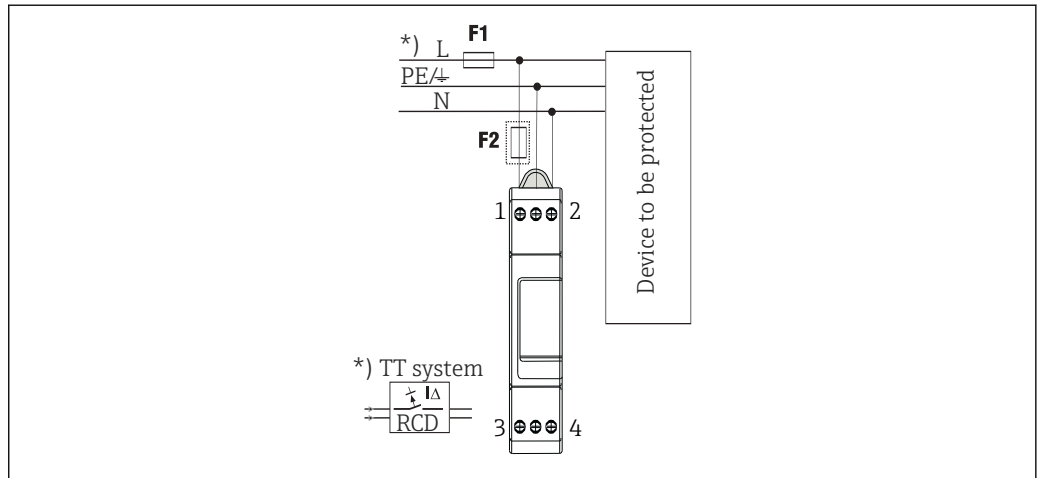

19 Parallel wiring HAW562-AAB, HAW562-AAC

A ground fault circuit interrupter must be provided in the TT system.

A second F2 ≤25 A gG back-up fuse must be provided for back-up fuse F1 > 25 A gG. No second F2 back-up fuse is required for F1 ≤25 A gG back-up fuses.

SPD class

HAW562					
-AAA	-AAB	-AAC	-AAD	-AAE	-8DA
Type 1 P1	Type 3 P3		Type 1 P1		

Supply voltage

Nominal voltage

HAW562					
-AAA	-AAB	-AAC	-AAD	-AAE	-8DA
24 V	60 V	230 V	5 V	Terminal 4: 12 V DC Terminal 2: 80 V DC	24 V

Maximum continuous voltage

	HAW562					
	-AAA	-AAB	-AAC	-AAD	-AAE	-8DA
DC:	33.0 V	75 V	255 V	6.0 V	Terminal 4: 15.0 V DC Terminal 2: 180 V DC	33.0 V
AC:	23.3 V			4.2 V		23.3 V

Current consumption

	HAW562					
	-AAA	-AAB	-AAC	-AAD	-AAE	-8DA
Nominal current [I _L]	1.0 A	25 A	25 A	1.0 A	Terminal 4: 0.45 A Terminal 2: 3 A	500 mA at T _{amb} 80 °C (176 °F)
C2 nominal discharge current [I _n] (8/20) per line	10 kA	2 kA	3 kA	10 kA	10 kA	5 kA

	HAW562					
	-AAA	-AAB	-AAC	-AAD	-AAE	-8DA
C2 nominal discharge current $[I_n]$ (8/20) total	20 kA	4 kA	5 kA	20 kA	20 kA	10 kA
Short circuit withstand capability at mains-side overcurrent protection with 25 A gL/gG (I_{SCCR})		6 kA _{eff}	6 kA _{eff}			
D1 lightning surge current $[I_{imp}]$ (10/350) per line	2.5 kA			2.5 kA	2.5 kA	1 kA
D1 lightning surge current $[I_{imp}]$ (10/350) total	9 kA			9 kA	7.5 kA	2 kA

Voltage protection level

	HAW562					
	-AAA	-AAB	-AAC	-AAD	-AAE	-8DA
Line/line	≤ 52 V at I_{imp}	L - N: ≤ 400 V	L - N: ≤ 1250 V	≤ 25 V		≤ 52 V
Line/PG	≤ 550 V at I_{imp}	L/N - PE: ≤ 730 V	L/N - PE: ≤ 1500 V	≤ 550 V	≤ 600 V	≤ 1400 V

Response times

	HAW562					
	-AAA	-AAB	-AAC	-AAD	-AAE	-8DA
Line/line	≤ 1 ns	L - N: ≤ 25 ns	L - N: ≤ 25 ns	≤ 1 ns	≤ 1 ns	≤ 1 ns
Line/PG	≤ 100 ns	L/N - PE: ≤ 100 ns	L/N - PE: ≤ 100 ns	≤ 100 ns	≤ 100 ns	≤ 100 ns

Limit frequency

	HAW562					
	-AAA	-AAB	-AAC	-AAD	-AAE	-8DA
7.8 MHz			100 MHz	Terminal 4: 2 MHz Terminal 2: 15 MHz		7.7 MHz (50 Ohm) 3.2 MHz (100 Ohm)

Series impedance per line

	HAW562					
	-AAA	-AAB	-AAC	-AAD	-AAE	-8DA
1.0 Ohm	-	-	1.0 Ohm	Terminal 4: 1.8 Ohm Terminal 1+2: directly connected		1.0 Ohm

Capacitance

	HAW562					
	-AAA	-AAB	-AAC	-AAD	-AAE	-8DA
Line/line	≤ 1.0 nF	-	-	≤ 25 pF	-	≤ 0.8 nF
Line/PG	≤ 25 pF	-	-	≤ 25 pF	-	≤ 16 pF

Maximum line side overcurrent protection

Only for unit types HAW562-AAB and HAW562-AAC:
25 A gG or B 25 A

Shield grounding

As a rule, cable shielding must be grounded across its entire length. The shielding should be grounded by means of direct shield grounding at least at both ends of the cable.

If direct grounding of the shield at both ends is not possible or desired, e.g. to avoid low-frequency equalizing currents, indirect shield grounding should be provided at one end. Equalizing currents are thus avoided yet EMC requirements are still met. Indirect shield grounding occurs via a gas discharge tube installed in the overvoltage protection module.

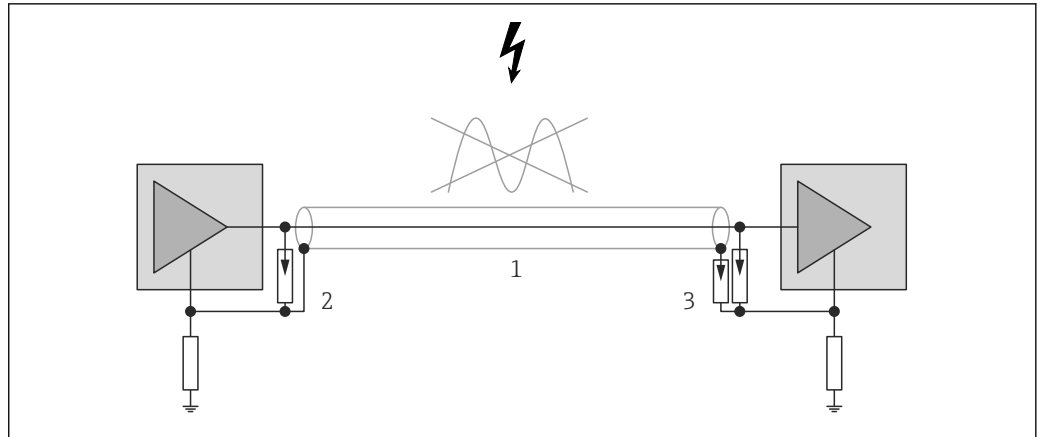

A0015047

20 Direct and indirect shield grounding

- 1 Cable shielding
- 2 Direct shield grounding
- 3 Indirect shield grounding

Both direct and indirect shield grounding is possible using the shield grounding terminal available as an accessory (not for HAW562-AAB, -AAC, -AAE). The insulating strip included in the delivery is fitted on one of the two connector pins for this purpose. The free pin then provides the required shield grounding.

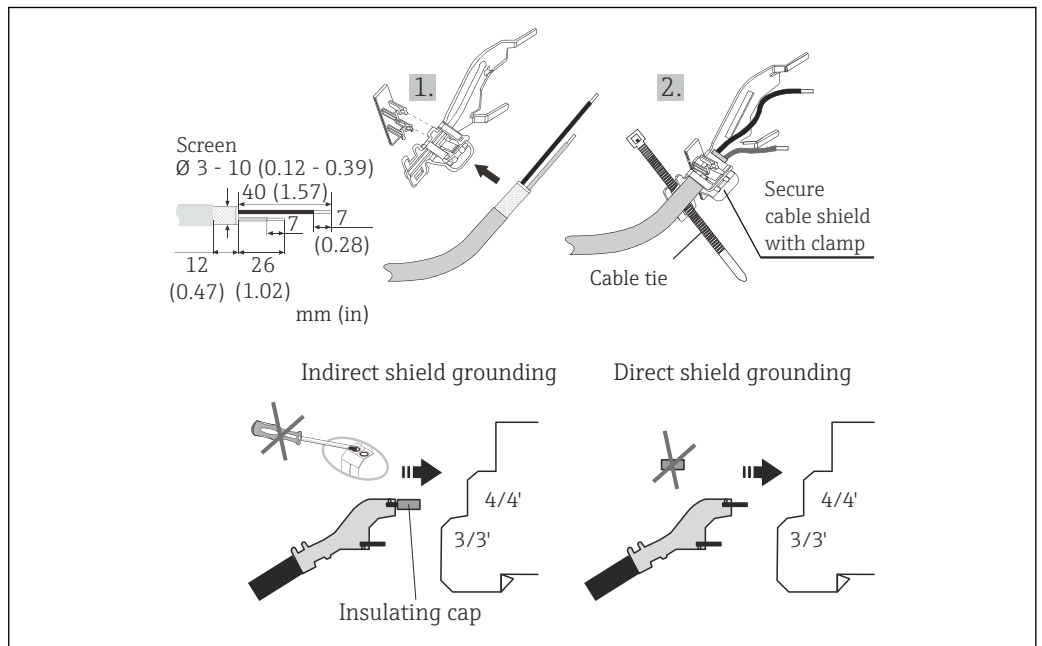

A0015045-EN

21 Shield grounding with HAW562

Installation

Installation instructions

Mounting location

Installation on 35 mm top hat rail to EN 60715

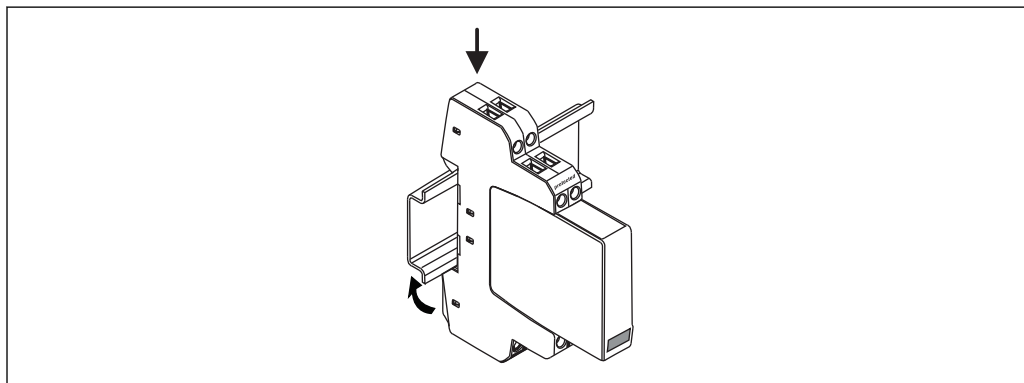

A0015069

22 Installation on top hat rail, drawing as example

Multiple unit installation

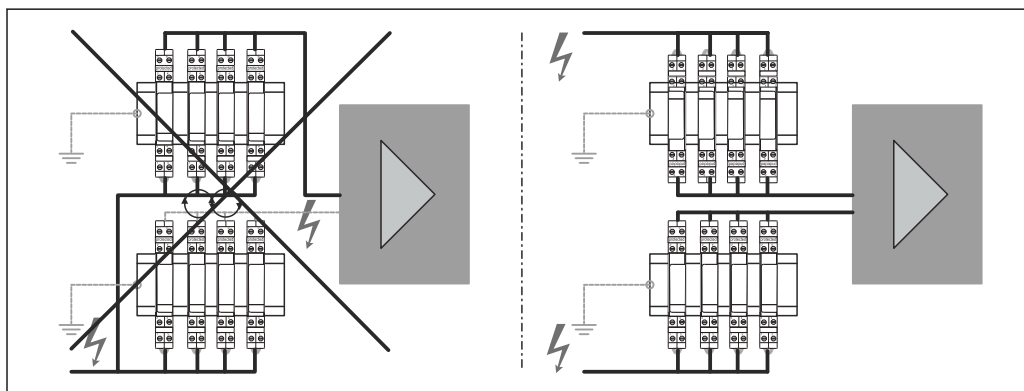

A0015101

23 Multiple unit installation

Environment

Ambient temperature range -40 to +80 °C (-40 to +176 °F)

Humidity 5 to 95 %

Storage temperature See "Ambient temperature range"

Degree of protection IP 20

Mechanical construction

Dimensions

HAW562-AAA, HAW562-AAD, HAW562-AAE, HAW562-8DA

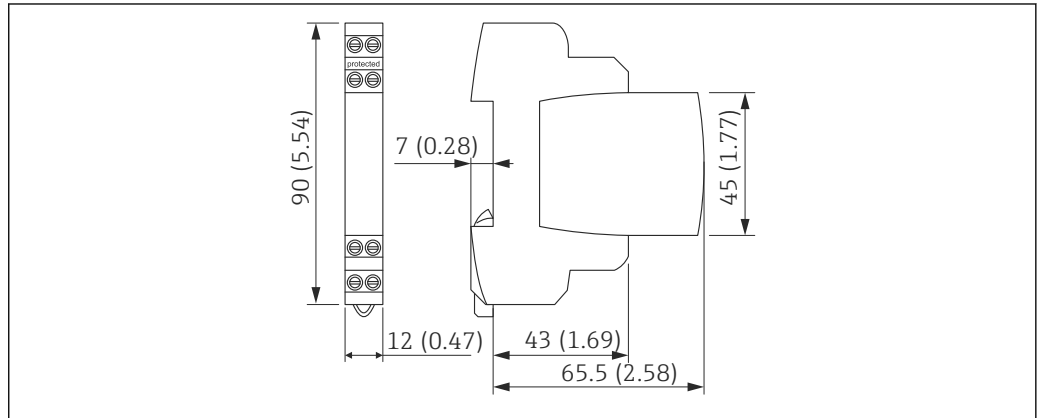

A0015075

24 Dimensions in mm (dimensions in inches in brackets)

HAW562-AAB, HAW562-AAC

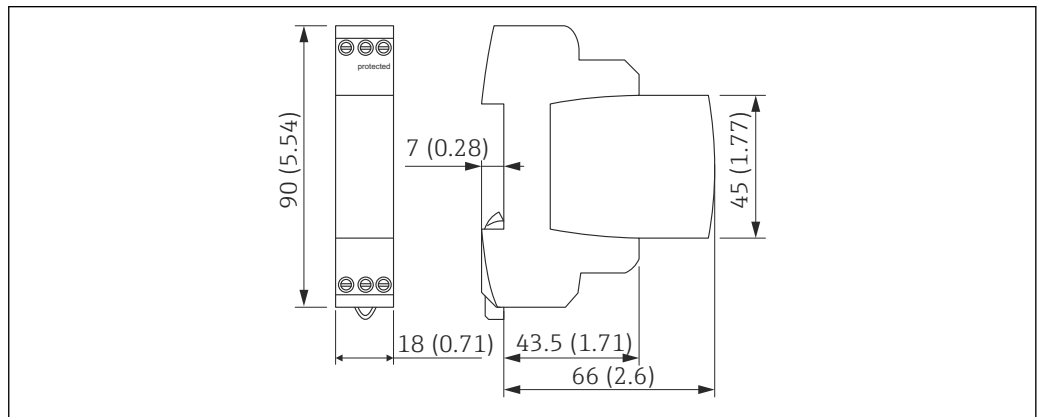

A0015076

25 Dimensions in mm (dimensions in inches in brackets)

Weight

HAW562-AAA, HAW562-AAD, HAW562-AAE, HAW562-8DA	HAW562-AAB, HAW562-AAC
60 g (2.12 oz.)	130 g (4.59 oz.)

Material

HAW562-AAA, HAW562-AAD, HAW562-AAE, HAW562-8DA	HAW562-AAB, HAW562-AAC
Polyamide PA 6.6	Thermoplast UL 94 V-0

Terminals

	HAW562-AAA, HAW562-AAD, HAW562-AAE, HAW562-8DA	HAW562-AAB, HAW562-AAC
Single strand cables	0.08 to 4 mm ² (28 to 12 AWG)	0.5 to 4 mm ² (21 to 12 AWG)
Multi strand cables	0.08 to 2.5 mm ² (28 to 14 AWG)	0.5 to 2.5 mm ² (21 to 14 AWG)

Human interface

Display elements

HAW562-AAB/HAW562-AAC

Green display (= functional) in sight window. The energy transfer of the units is controlled by the integrated thermal monitoring system. In the event of a defect (= red display window - means thermal overload) this monitoring system will automatically separate the surge arrester from the power source.

All other HAW562 units do not have any display elements.

NOTICE

Defective surge arrester

Electric units connected are then no longer protected from overvoltages.

- ▶ Replace surge arrester immediately.

HAW562-AAA, HAW562-AAD, HAW562-AAE, HAW562-8DA

These units do not have any display elements.

NOTICE

Defective surge arrester

Signal cable short circuit.

- ▶ The short circuit is rectified when the defective protection module is taken out of the carrier. Electric units connected are no longer protected from overvoltages. Replace surge arrester immediately.

Certificates and approvals

CE mark

The measuring system meets the legal requirements of the EC Directives. Endress+Hauser confirms successful testing of the device by affixing to it the CE mark.

Ex approval

Information about currently available Ex versions (ATEX, FM, CSA, etc.) can be supplied by your E+H Sales Center on request. All explosion protection data are given in separate documentation which is available upon request.

Other standards and guidelines

- IEC 61010: Safety requirements for electrical equipment for measurement, control and laboratory use
- IEC 61326: Electromagnetic compatibility (EMC requirements)

HAW562-AAB / -AAC	HAW562-AAA / -AAD / -AAE / -8DA
IEC 61643-1 EN 61643-11	IEC 61643-21:1999-07 A2, B2, C2, C3, D1

Ordering information

Detailed ordering information is available from the following sources:

- In the Product Configurator on the Endress+Hauser website: www.endress.com → Select country → Instruments → Select device → Product page function: Configure this product
- From your Endress+Hauser Sales Center: www.endress.com/worldwide



Product Configurator - the tool for individual product configuration

- Up-to-the-minute configuration data
- Depending on the device: Direct input of measuring point-specific information such as measuring range or operating language
- Automatic verification of exclusion criteria
- Automatic creation of the order code and its breakdown in PDF or Excel output format
- Ability to order directly in the Endress+Hauser Online Shop

Accessories

Shield grounding terminal

Only for HAW562-AAA, HAW562-AAD and HAW562-8DA, (→  12).

Order as an additional option in the product structure for HAW562 or separately via order code: RK01-AN

Field housing

Protective housing with integrated carrier rail to install up to four HAW562 devices:

Integrated DIN rail; ground connection; GORE-TEX® filter; 2 sealing screws and 4 plastic M20 cable entries; material: die-cast aluminum, epoxy coating, degree of protection IP 66/NEMA4x.

Order as an additional option in the product structure for HAW562 or separately via order code: RK01-AO

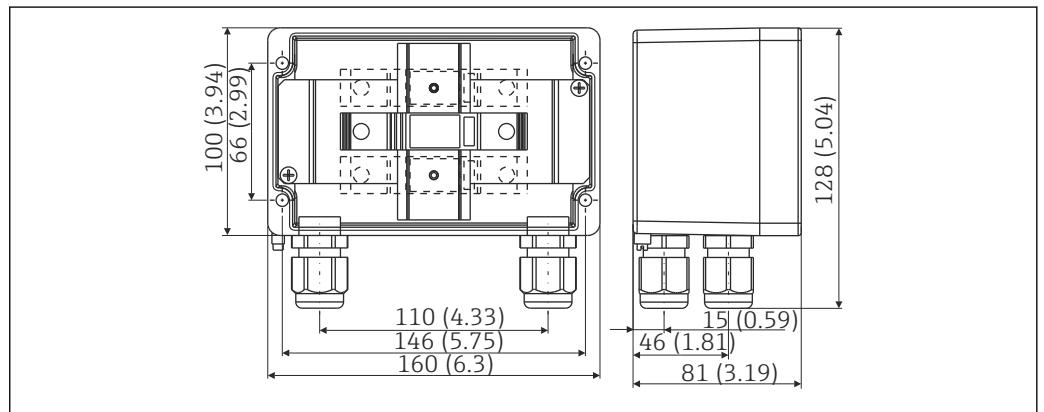

 26 Dimensions in mm (dimensions in inches in brackets)

Mounting bracket for mounting the protective housing on a wall or pipe:

Order as an additional option in the product structure for HAW562 or separately via order code: RK01-AP

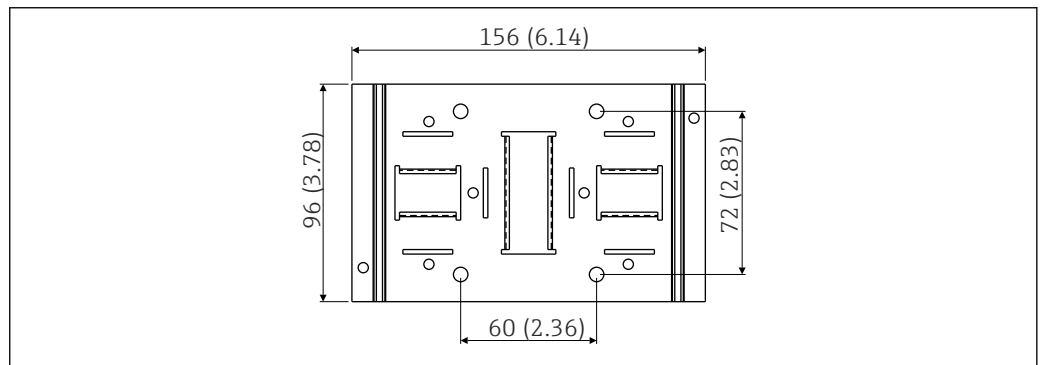

 27 Dimensions in mm (dimensions in inches in brackets)

Documentation

- Brochure 'System components: Indicators with control unit for field and panel mounting, power supplies, barriers, transmitters, energy managers and surge arresters' (FA016K/09)
- Operating Instructions HAW562-AAB, HAW562-AAC (BA00302K/09/a2)
- Operating Instructions HAW562-AAA, HAW562-AAD, HAW562-8DA (BA00303K/09/a2)
- Operating Instructions HAW562-AAE (BA00306K/09/a2)
- Ex-related supplementary documentation:
ATEX / IECEx II (1)GD [Ex ia] IIC: XA01002K/09/a3

www.addresses.endress.com
