

# Technical Information

## Cerabar M

### PMC51, PMP51, PMP55

Process pressure measurement

### Pressure transmitter with ceramic and metallic sensors



#### Application

The device is used for the following measuring tasks:

- Absolute pressure and gauge pressure measurement in gases, steams or liquids in all areas of process engineering and process measurement technology
- Level, volume or mass measurements in liquids
- High process temperature
  - without diaphragm seals up to 130 °C (266°F), for a maximum of 60 minutes
  - 150 °C (302°F)
  - with diaphragm seals up to 400 °C (752°F)
- High pressure up to 400 bar (6000 psi)
- International usage thanks to a wide range of approvals

#### Your benefits

- Very good reproducibility and long-term stability
- High reference accuracy: up to  $\pm 0.15\%$ , as PLATINUM version:  $\pm 0.075\%$
- Turn down up to 100:1
- Standardized platform for differential pressure, hydrostatics, and pressure (Deltabar M – Deltapilot M – Cerabar M)
- Simple, fast commissioning through a user interface designed for real-world applications
- Used for process pressure monitoring up to SIL2, certified to IEC 61508 Edition 2.0 and IEC 61511 by TÜV NORD
- New TempC diaphragm for diaphragm seals: Minimum temperature effects, maximum diaphragm thickness and short recovery times
- Device versions compliant with ASME-BPE

## Table of contents

<b>Document information</b> .....	<b>5</b>	Long-term stability .....	29
Symbols used .....	5	Total error - PMC51 .....	30
Terms and abbreviations .....	7	Warm-up period .....	30
Turn down calculation .....	8		
<b>Function and system design</b> .....	<b>9</b>	<b>Performance characteristics of the metallic process isolating diaphragm</b> .....	<b>31</b>
Device selection .....	9	Reference operating conditions .....	31
Measuring principle .....	10	Influence of orientation .....	31
Level measurement (level, volume and mass) .....	11	Uncertainty of measurement for small absolute pressure ranges	31
Electrical differential pressure measurement with gauge		Reference accuracy – PMP51, PMP55 .....	32
pressure sensors .....	12	Thermal change in the zero output and the output span – PMP51	
Communication and data processing .....	12	and PMP55 .....	33
		Total performance – PMP51 .....	34
		Long-term stability .....	34
		Total error - PMP51 .....	35
		Warm-up period .....	35
<b>Input</b> .....	<b>13</b>	<b>Installation</b> .....	<b>36</b>
Measured variable .....	13	General installation instructions .....	36
Measuring range .....	13	Measuring arrangement for devices without diaphragm seal –	
		PMC51, PMP51 .....	36
		Measuring arrangement for devices with diaphragm seal –	
		PMP55 .....	36
		Wall and pipe mounting, transmitter (optional) .....	37
		Wall and pipe mounting manifold (optional) .....	37
		"Separate housing" version .....	38
		Oxygen applications .....	39
		PWIS cleaning .....	39
		Ultrapure gas applications (PMC51 and PMP51) .....	39
		Applications with hydrogen .....	39
<b>Output</b> .....	<b>15</b>	<b>Environment</b> .....	<b>40</b>
Output signal .....	15	Ambient temperature range .....	40
Signal range .....	15	Storage temperature range .....	40
Signal on alarm .....	15	Climate class .....	40
Load - 4 to 20 mA analog and 4 to 20 mA HART .....	15	Degree of protection .....	40
Resolution .....	16	Vibration resistance .....	41
Dead time, Time constant .....	16	Electromagnetic compatibility .....	41
Dynamic behavior: current output (analog electronics) .....	16		
Dynamic behavior: current output (HART electronics) .....	16	<b>Process</b> .....	<b>42</b>
Dynamic behavior: digital output (HART electronics) .....	16	Process temperature range PMC51 .....	42
Dynamic behavior: PROFIBUS PA .....	17	Process temperature limits .....	42
Dynamic behavior: FOUNDATION Fieldbus .....	17	Process temperature limits of flexible capillary armoring: PMP55	
Damping .....	17	.....	44
Firmware version .....	18	Pressure specifications .....	44
Protocol-specific data .....	18		
<b>Power supply</b> .....	<b>22</b>	<b>Mechanical construction</b> .....	<b>45</b>
Terminal assignment .....	22	Device height .....	45
Supply voltage .....	22	F31 housing, aluminum .....	45
Current consumption .....	23	F15 housing, stainless steel (hygienic) .....	46
Electrical connection .....	23	PMC51: process connections with internal process isolating	
Terminals .....	23	diaphragm .....	47
Cable entry .....	23	PMC51: process connections with internal process isolating	
Connector .....	24	diaphragm .....	48
Cable specification .....	25	PMC51: process connections with internal process isolating	
Start-up current .....	26	diaphragm .....	49
Residual ripple .....	26		
Influence of power supply .....	26		
Overvoltage protection (optional) .....	26		
<b>Performance characteristics of the ceramic process isolating diaphragm</b> .....	<b>27</b>		
Reference operating conditions .....	27		
Influence of orientation .....	27		
Uncertainty of measurement for small absolute pressure ranges			
27			
Reference accuracy – PMC51 .....	28		
Thermal change in the zero output and the output span – PMC51			
.....	28		
Total performance – PMC51 .....	29		





PMC51: process connections with internal process isolating diaphragm - height H	49	<b>Operability</b>	<b>101</b>
PMC51: process connections with flush-mounted process isolating diaphragm	50	Operating concept	101
PMC51: process connections with flush-mounted process isolating diaphragm	51	Onsite operation	101
PMC51: process connections with flush-mounted process isolating diaphragm - height H	51	Operating languages	104
PMC51: process connections with flush-mounted process isolating diaphragm	52	Remote operation	104
PMC51: process connections with flush-mounted process isolating diaphragm	53	System integration (except analog electronics)	106
PMC51: process connections with flush-mounted process isolating diaphragm	54	<b>Planning instructions for diaphragm seal systems</b>	<b>107</b>
PMC51: process connections with flush-mounted process isolating diaphragm - height H	54	Applications	107
PMC51: hygienic process connections with flush-mounted process isolating diaphragm	55	Function and design	108
PMP51: process connections with internal process isolating diaphragm	60	Diaphragm seal filling oils	109
PMP51: process connections with internal process isolating diaphragm	61	Operating temperature range	109
PMP51: process connections with flush-mounted process isolating diaphragm	62	Cleaning instructions	109
PMP51: process connections with flush-mounted process isolating diaphragm	63	Installation instructions	110
PMP51: process connections with flush-mounted process isolating diaphragm	64	Vacuum applications	112
PMP51: process connections with flush-mounted process isolating diaphragm	65	<b>Certificates and approvals</b>	<b>113</b>
PMP51: process connections with flush-mounted process isolating diaphragm	66	CE mark	113
PMP51: hygienic process connections with flush-mounted process isolating diaphragm	67	RCM-Tick marking	113
Valve manifold DA63M (optional)	71	Ex approvals	113
PMP51: process connections	72	EAC conformity	113
PMP55 basic device - examples	73	Suitable for hygiene applications	113
PMP55: process connections with flush-mounted process isolating diaphragm	74	Certificate of Compliance ASME BPE 2012	114
PMP55: process connections with flush-mounted process isolating diaphragm	75	Functional safety SIL	114
PMP55: process connections with flush-mounted process isolating diaphragm	76	CRN approvals	114
PMP55: process connections with flush-mounted process isolating diaphragm	77	Standards and guidelines	114
PMP55: hygienic process connections with flush-mounted process isolating diaphragm	78	AD2000	114
PMP55: hygienic process connections with flush-mounted process isolating diaphragm	79	Pressure Equipment Directive 2014/68/EU (PED)	114
PMP55: hygienic process connections with flush-mounted process isolating diaphragm	81	Manufacturer declaration	115
PMP55: process connections with flush-mounted process isolating diaphragm	85	Marine approval	115
PMP55: process connections with flush-mounted process isolating diaphragm	87	Drinking water approval	116
PMP55 process connections	90	Classification of process sealing between electrical systems and (flammable or combustible) process fluids in accordance with ANSI/ISA 12.27.01	116
Wall and pipe mounting with mounting bracket	93	Inspection certificate	116
Reduction in installation height	94	Calibration; unit	116
Weight	94	Calibration	117
Materials not in contact with process	95	Service	117
Materials in contact with the process	98	<b>Ordering information</b>	<b>118</b>
Fill fluid	100	Configuration data sheet (HART, PROFIBUS PA, FOUNDATION Fieldbus electronics)	118
		Configuration data sheet (analog electronics)	120
		<b>Documentation</b>	<b>121</b>
		Technical Information	121
		Special Documentation	121
		Operating Instructions	121
		Brief Operating Instructions	121
		Functional safety manual (SIL)	121
		Safety Instructions	121
		Installation/Control Drawings	123
		Combination certificate	123
		<b>Accessories</b>	<b>124</b>
		Manifolds	124
		Additional mechanical accessories	124
		Welding necks and Weld-in tool flanges	124
		Mounting bracket for wall and pipe mounting	125
		M12 connector	125

<b>Registered trademarks.....</b>	<b>125</b>
HART® .....	125
PROFIBUS® .....	125
FOUNDATION™ Fieldbus .....	125







## Document information

### Symbols used





#### Safety symbols

Symbol	Meaning
 <small>A0011189-EN</small>	<b>DANGER!</b> This symbol alerts you to a dangerous situation. Failure to avoid this situation will result in serious or fatal injury.
 <small>A0011190-EN</small>	<b>WARNING!</b> This symbol alerts you to a dangerous situation. Failure to avoid this situation can result in serious or fatal injury.
 <small>A0011191-EN</small>	<b>CAUTION!</b> This symbol alerts you to a dangerous situation. Failure to avoid this situation can result in minor or medium injury.
 <small>A0011192-EN</small>	<b>NOTE!</b> This symbol contains information on procedures and other facts which do not result in personal injury.









#### Electrical symbols

Symbol	Meaning
 <small>A0018335</small>	<b>Direct current</b> A terminal at which DC voltage is present or through which direct current flows.
 <small>A0018336</small>	<b>Alternating current</b> A terminal at which alternating voltage is present or through which alternating current flows.
 <small>A0018337</small>	<b>Direct current and alternating current</b> <ul style="list-style-type: none"> <li>▪ A terminal at which alternating voltage or DC voltage is present.</li> <li>▪ A terminal through which alternating current or direct current flows.</li> </ul>
 <small>A0018338</small>	<b>Ground connection</b> A grounded terminal which, as far as the operator is concerned, is grounded via a grounding system.
 <small>A0018339</small>	<b>Protective ground connection</b> A terminal which must be connected to ground prior to establishing any other connections.
 <small>A0011201</small>	<b>Equipotential connection</b> A connection that has to be connected to the plant grounding system: This may be a potential equalization line or a star grounding system depending on national or company codes of practice.



#### Tool symbols

Symbol	Meaning
 <small>A0011219</small>	Phillips head screwdriver
 <small>A0011220</small>	Flat-blade screwdriver
 <small>A0013442</small>	Torx screwdriver
 <small>A0011222</small>	Hexagon wrench
 <small>A0011221</small>	Allen screw

## Symbols for certain types of information

Symbol	Meaning
 A0011182	<b>Permitted</b> Indicates procedures, processes or actions that are permitted.
 A0011183	<b>Preferred</b> Indicates procedures, processes or actions that are preferred.
 A0011184	<b>Forbidden</b> Indicates procedures, processes or actions that are forbidden.
 A0011193	<b>Tip</b> Indicates additional information.
 A0015483	<b>Reference to documentation</b> Refers to the corresponding device documentation.
 A0015484	<b>Reference to page</b> Refers to the corresponding page number.
 A0015486	<b>Reference to graphics</b> Refers to the corresponding graphic number and page number.
1. , 2. , ...	Series of steps
 A0015488	<b>Help in the event of a problem</b>

## Symbols in graphics

Symbol	Meaning
1, 2, 3, 4 etc.	Numbering for main items
1. , 2. , ...	Series of steps
A, B, C, D etc.	Views
A-A, B-B, etc.	Sections
 A0011187	<b>Hazardous area</b> Indicates the hazardous area.
 A0011188	Safe area (non-hazardous area) Indicates the non-hazardous area.

Terms and abbreviations

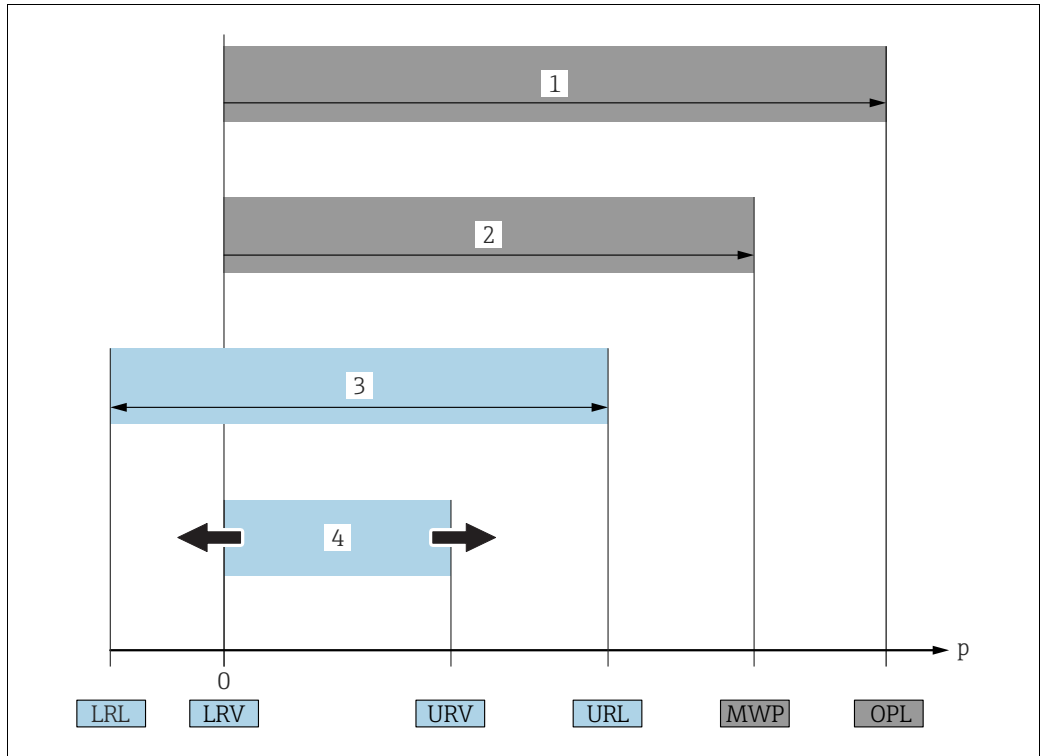

A0029505

Position	Term/Abbreviation	Explanation
1	OPL	The OPL (over pressure limit = sensor overload limit) for the sensors depends on the lowest-rated element, with regard to pressure, of the selected components, i.e. the process connection must be taken into consideration in addition to the measuring cell. Also observe pressure-temperature dependency. For the relevant standards and additional notes, see the "→ 44" section. The OPL may be applied for a limited time period.
2	MWP	The MWP (maximum working pressure) for the sensors depends on the lowest-rated element, with regard to pressure, of the selected components, i.e. the process connection has to be taken into consideration in addition to the measuring cell. Also observe pressure-temperature dependency. For the relevant standards and additional notes, see the "→ 44" section. The MWP may be applied for an unlimited time.
3	Maximum sensor measuring range	Range between LRL and URL This span is the maximum calibratable/adjustable measuring span.
4	Calibrated/Adjusted measuring span	Range between LRV and URV Factory setting: 0...URL Other calibrated spans can be ordered with customised settings.
p	-	Pressure
-	LRL	Lower range limit
-	URL	Upper range limit
-	LRV	Lower range value
-	URV	Upper range value
-	TD	Turn down

## Turn down calculation

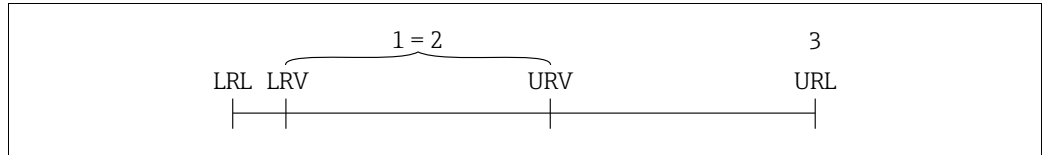

A0029545

- 1 Calibrated/Adjusted measuring span
- 2 Zero-based span
- 3 Upper range limit

**Example**

- Sensor: 10 bar (150 psi)
- Upper range limit (URL) = 10 bar (150 psi)
- Calibrated/Adjusted measuring span: 0...5 bar (0...75 psi)
- Lower range value (LRV) = 0 bar
- Upper range value (URV) = 5 bar (75 psi)

Turn down (TD):

$$TD = \frac{URL}{|URV - LRV|}$$

$$TD = \frac{10 \text{ bar (150 psi)}}{|5 \text{ bar (75 psi)} - 0 \text{ bar (0 psi)}|} = 2$$

In this example, the TD is thus 2:1.  
This span is based on the zero point.



## Function and system design

### Device selection

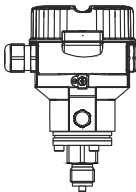
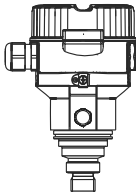
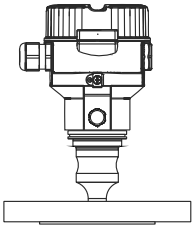
Cerabar M – Product family	PMC51  <small>A0023673</small> With capacitive measuring cell and ceramic process isolating diaphragm (Ceraphire®)	PMP51  <small>A0023675</small> With piezoresistive measuring cell and metallic welded process isolating diaphragm	PMP55  <small>A0023676</small> With diaphragm seal
Field of application	- Gauge pressure and absolute pressure - Level		
Process connections	- Thread - EN flanges DN 25 – DN 80 - ANSI flanges 1" – 4" - JIS flanges 50 A – 100 A - Flush-mounted hygienic connections	- Thread - EN flanges DN 25 – DN 80 - ANSI flanges 1" – 4" - Prepared for diaphragm seal mount - Flush-mounted hygienic connections	- Wide range of diaphragm seals
Measuring ranges	From -100/0 to 100 mbar (-1.5/0 to 1.5 psi) to -1/0 to 40 bar (-15/0 to 600 psi)	From -400/0 to 400 mbar (-6/0 to 6 psi) to -1/0 to 400 bar (-15/0 to 6000 psi)	
OPL	Max. 60 bar (900 psi)	Max. 600 bar (9000 psi)	
Process temperature range	-20 to +130 °C (-4 to +266°F) For a maximum of 60 minutes: +150 °C (+302°F)	-40 to +130 °C (-40 to +266°F) For a maximum of 60 minutes: +150 °C (+302°F)	-70 to 400 °C (-94 to +752°F) depending on the filling oil
Ambient temperature range	- Without LCD display: -40 to +85 °C (-40 to +185°F) - With LCD display: -20 to +70 °C (-4 to +158°F) (extended temperature application range (-40 to 85 °C (-40 to 185°F)) with restrictions in optical properties such as display speed and contrast) - Separate housing: -20 to +60 °C (-4 to +140°F) - Diaphragm seal systems depending on the version		
Reference accuracy	- Up to ±0.15% of the set span - PLATINUM version: up to ±0.075% of the set span		Up to ±0.15% of the set span
Supply voltage	- 11.5 to 45 V DC (versions with plug-in connection 35 V DC) - For intrinsically safe device versions: 11.5 to 30 V DC		
Output	4 to 20 mA, 4 to 20 mA with superimposed HART protocol		
Options	- NACE-compliant materials - PMC51, PMP51, PMP55: inspection certificate 2.2 or 3.1 or other certificates - 3A approval and EHEDG approval - Specific firmware versions - Initial device settings - Separate housing - Broad range of accessories		
Specialties	- Metal-free measurement with PVDF connection - Special cleaning of the transmitter to remove paint-wetting substances, for use in paint shops	- Process connections with minimum oil volume - Gas-tight, elastomer-free	- Wide range of diaphragm seals - For extreme medium temperatures - Process connections with minimum oil volume - Completely welded versions

## Measuring principle

## Ceramic process isolating diaphragm used in PMC51 (Ceraphire®)

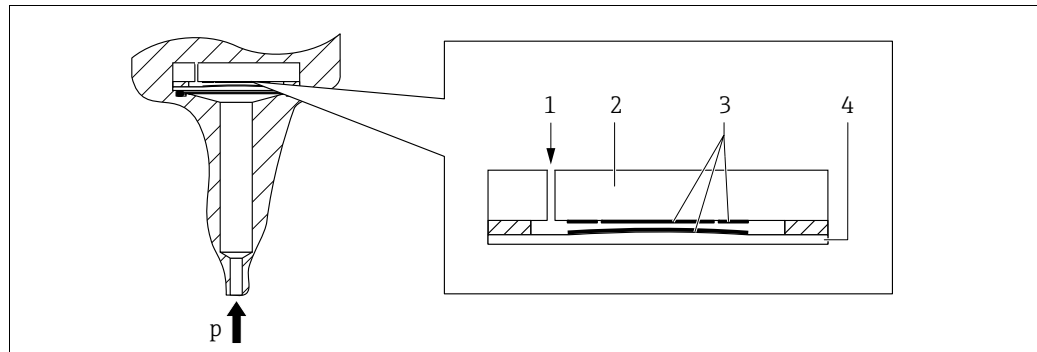

A0020465

## Ceramic sensor

- |   |                                       |
|---|---------------------------------------|
| 1 | Air pressure (gauge pressure sensors) |
| 2 | Ceramic substrate                     |
| 3 | Electrodes                            |
| 4 | Ceramic process isolating diaphragm   |

The ceramic sensor is a dry sensor, i.e. the process pressure acts directly on the robust ceramic process isolating diaphragm and deflects it. A pressure-dependent change in capacitance is measured at the electrodes of the ceramic substrate and the process isolating diaphragm. The measuring range is determined by the thickness of the ceramic process isolating diaphragm.

## Advantages:

- Guaranteed overload resistance up to 40 times the nominal pressure
- Thanks to ultrapure 99.9% ceramic (Ceraphire®, see also "www.endress.com/ceraphire")
  - extremely high chemical stability, comparable with Alloy C
  - high mechanical stability
- Can be used in absolute vacuum

## Metallic process isolating diaphragm used in PMP51 and PMP55

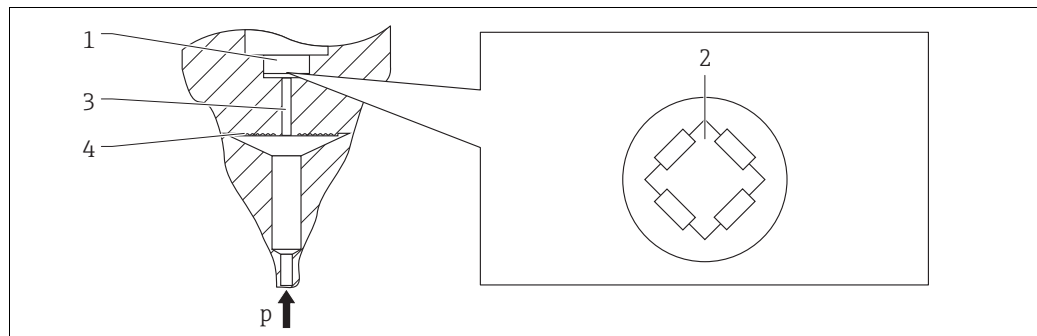

A0016448

## Metallic sensor

- |   |                                      |
|---|--------------------------------------|
| 1 | Silicon measuring element, substrate |
| 2 | Wheatstone bridge                    |
| 3 | Channel with fill fluid              |
| 4 | Metallic process isolating diaphragm |

## PMP51

The operating pressure deflects the process isolating diaphragm and a fill fluid transfers the pressure to a resistance bridge (semiconductor technology). The pressure-dependent change in the bridge output voltage is measured and evaluated.

## Advantages:

- Can be used for process pressure up to 400 bar (6000 psi)
- High long-term stability
- Guaranteed overload resistance up to 4 times the nominal pressure
- Significantly less thermal effect compared to diaphragm seal systems

*PMP55*

The operating pressure acts on the process isolating diaphragm of the diaphragm seal and is transferred to the process isolating diaphragm of the sensor by a diaphragm seal fill fluid. The process isolating diaphragm is deflected and a fill fluid transfers the pressure to a resistance bridge. The pressure-dependent change in the bridge output voltage is measured and evaluated.

Advantages:

- Depending on the version, can be used for process pressure up to 400 bar (6000 psi) and simultaneous extreme process temperatures
- High long-term stability
- Guaranteed overload resistance up to 4 times the nominal pressure

### Level measurement (level, volume and mass)

### Function and design

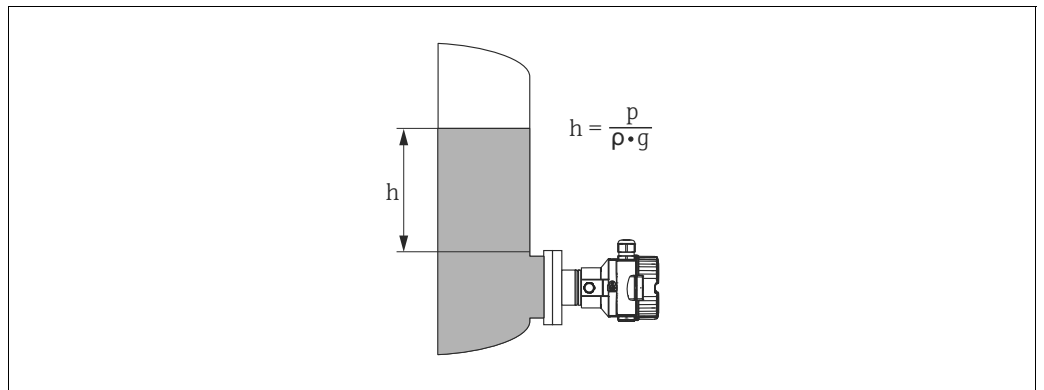

*Level measurement*

<i>h</i>	<i>Height (level)</i>
<i>p</i>	<i>Pressure</i>
<i>ρ</i>	<i>Density of the medium</i>
<i>g</i>	<i>Gravitation constant</i>

### Your benefits

- Choice of different level measuring modes in the device software
- Volume and mass measurements in any vessel shapes by means of a freely programmable characteristic curve
- Choice of diverse level units
- Has a wide range of uses, even in the following cases:
  - in the event of foam formation
  - in vessels with agitators or screen fittings
  - in the event of liquid gases

## Electrical differential pressure measurement with gauge pressure sensors

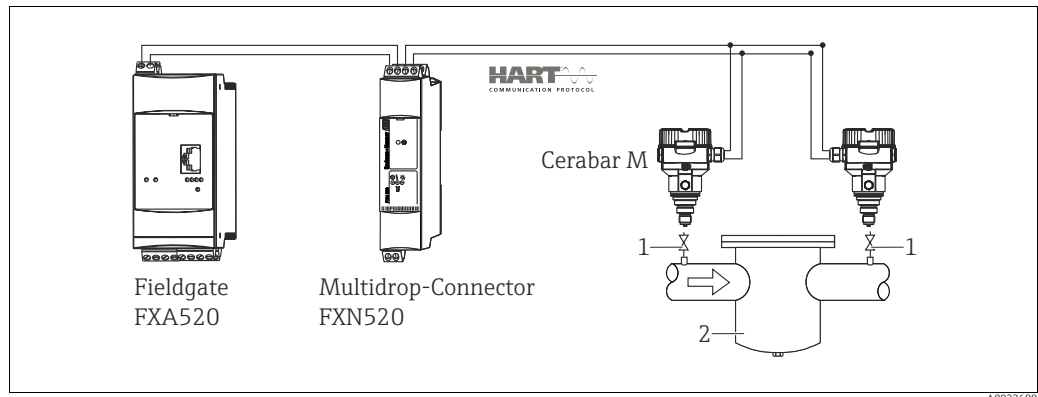

1 Shut-off valves

2 e.g. filter

In the example given, two Cerabar M devices (each with a gauge pressure sensor) are interconnected. The pressure difference can thus be measured using two independent Cerabar M devices.

### **▲ WARNING**

#### **Risk of explosion!**

- ▶ If using intrinsically safe devices, strict compliance with the rules for interconnecting intrinsically safe circuits as stipulated in IEC60079-14 (proof of intrinsic safety) is mandatory.

## Communication and data processing

- 4 to 20 mA without communication protocol (analog electronics)
  - 4 to 20 mA with HART communication protocol
  - PROFIBUS PA
    - The Endress+Hauser devices meet the requirements of the FISCO model.
    - Due to the low current consumption of  $11 \text{ mA} \pm 1 \text{ mA}$ , the following number of devices can be operated on one bus segment if installing as per FISCO:
      - up to 8 Cerabar M for Ex ia, CSA IS and FM IS applications
      - up to 31 Cerabar M for all other applications, e.g. in non-hazardous areas, Ex nA, etc.
- Further information on PROFIBUS PA can be found in Operating Instructions BA00034S "PROFIBUS DP/PA: Guidelines for planning and commissioning" and in the PNO Guideline.
- FOUNDATION Fieldbus
    - The Endress+Hauser devices meet the requirements of the FISCO model.
    - Due to the low current consumption of  $16 \text{ mA} \pm 1 \text{ mA}$ , the following number of devices can be operated on one bus segment if installing as per FISCO:
      - up to 6 Cerabar M for Ex ia, CSA IS and FM IS applications
      - up to 22 Cerabar M for all other applications, e.g. in non-hazardous areas, Ex nA, etc.
- Further information on FOUNDATION Fieldbus, such as requirements for bus system components can be found in Operating Instructions BA00013S "FOUNDATION Fieldbus Overview".

## Input

### Measured variable

- Analog electronics: Absolute pressure and gauge pressure
- HART electronics: Absolute pressure and gauge pressure, from which level (level, volume or mass) is derived

### Measuring range

#### PMC51 – with ceramic process isolating diaphragm (Ceraphire®) for gauge pressure

Sensor	Maximum sensor measuring range		Smallest calibratable measuring span (preset at the factory) <sup>1)</sup>	MWP	OPL	Vacuum resistance	Option <sup>2)</sup>
	lower (LRL) [bar (psi)]	upper (URL) [bar (psi)]					
100 mbar (1.5 psi)	-0.1 (-1.5)	+0.1 (+1.5)	0.01 (0.15)	2.7 (40.5)	4 (60)	0.7 (10.5)	1C
250 mbar (3.75 psi)	-0.25 (-3.75)	+0.25 (+3.75)	0.01 (0.15)	3.3 (49.5)	5 (75)	0.5 (7.5)	1E
400 mbar (6 psi)	-0.4 (-6)	+0.4 (+6)	0.02 (0.3)	5.3 (79.5)	8 (120)	0	1F
1 bar (15 psi)	-1 (-15)	+1 (+15)	0.05 (1)	6.7 (100.5)	10 (150)	0	1H
2 bar (30 psi)	-1 (-15)	+2 (+30)	0.1 (1.5)	12 (180)	18 (270)	0	1K
4 bar (60 psi)	-1 (-15)	+4 (+60)	0.2 (3)	16.7 (250.5)	25 (375)	0	1M
10 bar (150 psi)	-1 (-15)	+10 (+150)	0.5 (7.5)	26.7 (400.5)	40 (600)	0	1P
40 bar (600 psi)	-1 (-15)	+40 (+600)	2 (30)	40 (600)	60 (900)	0	1S

1) Factory calibration turn down: Max 20:1, higher on request or configurable in the device.

2) Product Configurator, "Sensor range" ordering feature

#### PMC51 – with ceramic process isolating diaphragm (Ceraphire®) for absolute pressure

Sensor	Maximum sensor measuring range		Smallest calibratable measuring span (preset at the factory) <sup>1)</sup>	MWP	OPL	Vacuum resistance	Option <sup>2)</sup>
	lower (LRL) [bar <sub>abs</sub> (psi <sub>abs</sub> )]	upper (URL) [bar <sub>abs</sub> (psi <sub>abs</sub> )]					
100 mbar (1.5 psi)	0	+0.1 (+1.5)	0.01 (0.15)	2.7 (40.5)	4 (60)	0	2C
250 mbar (3.75 psi)	0	+0.25 (+3.75)	0.01 (0.15)	3.3 (49.5)	5 (75)	0	2E
400 mbar (6 psi)	0	+0.4 (+6)	0.02 (0.3)	5.3 (79.5)	8 (120)	0	2F
1 bar (15 psi)	0	+1 (+15)	0.05 (1)	6.7 (100.5)	10 (150)	0	2H
2 bar (30 psi)	0	+2 (+30)	0.1 (1.5)	12 (180)	18 (270)	0	2K
4 bar (60 psi)	0	+4 (+60)	0.2 (3)	16.7 (250.5)	25 (375)	0	2M
10 bar (150 psi)	0	+10 (+150)	0.5 (7.5)	26.7 (400.5)	40 (600)	0	2P
40 bar (600 psi)	0	+40 (+600)	2 (30)	40 (600)	60 (900)	0	2S

1) Factory calibration turn down: Max 20:1, higher on request or configurable in the device.

2) Product Configurator, "Sensor range" ordering feature

## PMP51 and PMP55 – metallic process isolating diaphragm for gauge pressure

Sensor	Maximum sensor measuring range		Smallest calibratable measuring span (preset at the factory) <sup>1)</sup>	MWP	OPL	Vacuum resistance <sup>2)</sup> Silicone oil/ Inert oil/ Synthetic oil	Option <sup>3)</sup>
	lower (LRL) [bar (psi)]	upper (URL) [bar (psi)]					
400 mbar (6 psi)	-0.4 (-6)	+0.4 (+6)	0.02 (0.3)	4 (60)	6 (90)	0.01/0.04/0.01 (0.15/0.6/0.15)	1F
1 bar (15 psi)	-1 (-15)	+1 (+15)	0.05 (1)	6.7 (100)	10 (150)		1H
2 bar (30 psi)	-1 (-15)	+2 (+30)	0.1 (1.5)	13.3 (200)	20 (300)		1K
4 bar (60 psi)	-1 (-15)	+4 (+60)	0.2 (3)	18.7 (280.5)	28 (420)		1M
10 bar (150 psi)	-1 (-15)	+10 (+150)	0.5 (7.5)	26.7 (400.5)	40 (600)		1P
40 bar (600 psi)	-1 (-15)	+40 (+600)	2 (30)	100 (1500)	160 (2400)		1S
100 bar (1500 psi)	-1 (-15)	+100 (+1500)	5 (75)	100 (1500)	400 (6000)		1U
400 bar (6000 psi)	-1 (-15)	+400 (+6000)	20 (300)	400 (6000)	600 (9000)		1W

- 1) Factory calibration turn down: Max 20:1, higher on request or configurable in the device.
- 2) The vacuum resistance applies to the measuring cell at reference conditions. The pressure and temperature application limits of the selected filling oil must also be observed for the PMP55. → 109, "Diaphragm seal filling oils" ordering feature.
- 3) Product Configurator, "Sensor range" ordering feature

## PMP51 and PMP55 – metallic process isolating diaphragm for absolute pressure

Sensor	Maximum sensor measuring range		Smallest calibratable measuring span (preset at the factory) <sup>1)</sup>	MWP	OPL	Vacuum resistance <sup>2)</sup> Silicone oil/ Inert oil/ Synthetic oil	Option <sup>3)</sup>
	lower (LRL) [bar <sub>abs</sub> (psi <sub>abs</sub> )]	upper (URL) [bar <sub>abs</sub> (psi <sub>abs</sub> )]					
400 mbar (6 psi)	0	+0.4 (+6)	0.02 (0.3)	4 (60)	6 (90)	0.01/0.04/0.01 (0.15/0.6/0.15)	2F
1 bar (15 psi)	0	+1 (+15)	0.05 (1)	6.7 (100)	10 (150)		2H
2 bar (30 psi)	0	+2 (+30)	0.1 (1.5)	13.3 (200)	20 (300)		2K
4 bar (60 psi)	0	+4 (+60)	0.2 (3)	18.7 (280.5)	28 (420)		2M
10 bar (150 psi)	0	+10 (+150)	0.5 (7.5)	26.7 (400.5)	40 (600)		2P
40 bar (600 psi)	0	+40 (+600)	2 (30)	100 (1500)	160 (2400)		2S
100 bar (1500 psi)	0	+100 (+1500)	5 (75)	100 (1500)	400 (6000)		2U
400 bar (6000 psi)	0	+400 (+6000)	20 (300)	400 (6000)	600 (9000)		2W

- 1) Factory calibration turn down: Max 20:1, higher on request or configurable in the device.
- 2) The vacuum resistance applies to the measuring cell at reference conditions. The pressure and temperature application limits of the selected filling oil must also be observed for the PMP55. → 109, "Diaphragm seal filling oils" ordering feature.
- 3) Product Configurator, "Sensor range" ordering feature

## Output

### Output signal

- 4 to 20 mA analog, 2-wire
- 4 to 20 mA with superimposed digital communication protocol HART 6.0, 2-wire
- Digital communication signal PROFIBUS PA (Profile 3.02)
- Digital communication signal FOUNDATION Fieldbus

Output	Option <sup>1)</sup>
4 to 20mA	1
4 to 20mA HART	2
PROFIBUS PA	3
FOUNDATION Fieldbus	4

1) Product Configurator, "Output" ordering feature

### Signal range

4 to 20 mA analog, 4 to 20 mA HART: 3.8 to 20.5 mA

### Signal on alarm

As per NAMUR NE 43

- 4 to 20 mA Analog:
  - Signal overshoot: > 20.5 mA
  - Signal undershoot: < 3.8 mA
  - Min Alarm (3.6 mA)
- 4 to 20 mA HART
  - Options:
    - Max. alarm: can be set from 21 to 23 mA (factory setting: 22 mA)
    - Hold measured value: last measured value is held
    - Min. alarm: 3.6 mA
- PROFIBUS PA: can be set in the Analog Input block,
  - Options: Last Valid Out Value (factory setting), Fail-safe Value, Status Bad
- FOUNDATION Fieldbus: can be set in the Analog Input block,
  - Options: Last Good Value, Fail-safe Value (factory setting), Wrong Value

### Load - 4 to 20 mA analog and 4 to 20 mA HART

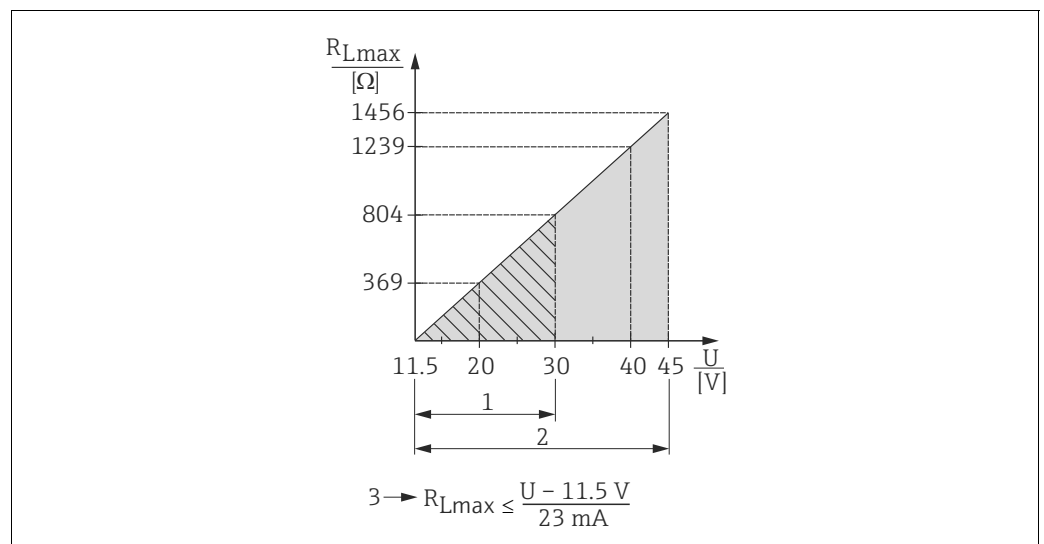

Load diagram

- 1 Power supply 11.5 to 30 V DC for intrinsically safe device versions (not for analog)
- 2 Power supply 11.5 to 45 V DC (versions with plug-in connector 35 V DC) for other types of protection and for uncertified device versions
- 3  $R_{Lmax}$  Maximum load resistance
- U Supply voltage



When operating via a handheld terminal or via a PC with an operating program, a minimum communication resistance of 250 Ω must be taken into account.

**Resolution**

- Current output: 1 μA
- Display: can be set (factory setting: presentation of the maximum accuracy of the transmitter)

**Dead time, Time constant**

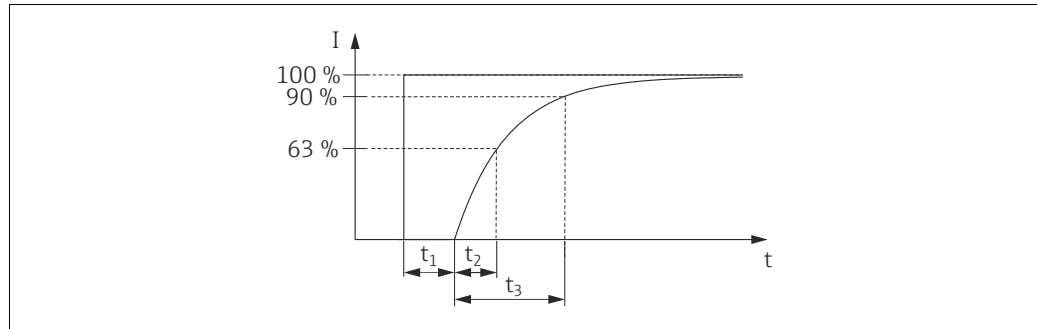

A0019786

Presentation of the dead time and the time constant

**Dynamic behavior: current output (analog electronics)**

	Type	Dead time (t <sub>1</sub> ) [ms]	Time constant T63 (= t <sub>2</sub> ) [ms]	Time constant T90 (= t <sub>3</sub> ) [ms]
Max.	PMC51	60	40	50
Max.	PMP51	40	40	50
Max.	PMP55	PMP51 + influence of the diaphragm seal		

**Dynamic behavior: current output (HART electronics)**

	Type	Dead time (t <sub>1</sub> ) [ms]	Time constant T63 (= t <sub>2</sub> ) [ms]	Time constant T90 (= t <sub>3</sub> ) [ms]
Max.	PMC51	50	85	200
Max.	PMP51	70	80	185
Max.	PMP55	PMP51 + influence of the diaphragm seal		

**Dynamic behavior: digital output (HART electronics)**

	Type	Dead time (t <sub>1</sub> ) [ms]	Dead time (t <sub>1</sub> ) [ms] + Time constant T63 (= t <sub>2</sub> ) [ms]	Dead time (t <sub>1</sub> ) [ms] + Time constant T90 (= t <sub>3</sub> ) [ms]
min.	PMC51	210	295	360
Max.		1010	1095	1160
min.	PMP51	210	285	345
Max.		1010	1085	1145
Max.	PMP55	PMP51 + influence of the diaphragm seal		

**Reading cycle**

- Acyclic: max. 3/s, typical 1/s (depends on command # and number of preambles)
- Cyclic (Burst): max. 3/s, typical 2/s

The Cerabar M commands the BURST MODE function for cyclic value transmission via the HART communication protocol.

**Cycle time (update time)**

Cyclic (Burst): min. 300 ms



**Response time**

- Acyclic: min. 330 ms, typical 590 ms (depends on command # and number of preambles)
- Cyclic (Burst): min. 160 ms, typical 350 ms (depends on command # and number of preambles)

**Dynamic behavior:  
PROFIBUS PA**

	Type	Dead time (t <sub>1</sub> ) [ms]	Dead time (t <sub>1</sub> ) [ms] + Time constant T63 (= t <sub>2</sub> ) [ms]	Dead time (t <sub>1</sub> ) [ms] + Time constant T90 (= t <sub>3</sub> ) [ms]
min.	PMC51	85	170	235
Max.		1185	1270	1335
min.	PMP51	85	160	220
Max.		1185	1260	1320
Max.	PMP55	PMP51 + influence of the diaphragm seal		

**Reading cycle**

- Cyclic: max. 30/s (dependent on the number and type of function blocks used in a closed-control loop)
- Acyclic: typical 25/s

**Cycle time (update time)**

min. 100 ms

The cycle time in a bus segment in cyclic data communication depends on the number of devices, on the segment coupler used and on the internal PLC cycle time.

**Response time**

- Cyclic: approx. 8 to 13 ms (depends on Min. Slave Interval)
- Acyclic: approx. 23 to 35 ms (depends on Min. Slave Interval)

**Dynamic behavior:  
FOUNDATION Fieldbus**

	Type	Dead time (t <sub>1</sub> ) [ms]	Dead time (t <sub>1</sub> ) [ms] + Time constant T63 (= t <sub>2</sub> ) [ms]	Dead time (t <sub>1</sub> ) [ms] + Time constant T90 (= t <sub>3</sub> ) [ms]
min.	PMC51	95	180	245
Max.		1095	1180	1245
min.	PMP51	95	170	230
Max.		1095	1170	1230
Max.	PMP55	PMP51 + influence of the diaphragm seal		

**Reading cycle**

- Cyclic: max. 10/s (dependent on the number and type of function blocks used in a closed-control loop)
- Acyclic: typical 5/s

**Cycle time (update time)**

Cyclic: min. 100 ms

**Response time**

- Cyclic: max. 20 ms (for standard bus parameter settings)
- Acyclic: typical 70 ms (for standard bus parameter settings)

**Damping**

A damping affects all outputs (output signal, display).

- Via on-site display, handheld terminal or PC with operating program, continuous from 0...999 s
- Via DIP-switch on the electronic insert, switch position "on" (= set value) and "off" (= damping switched off)
- Factory setting: 2 s

## Firmware version

Designation	Option <sup>1)</sup>
01.00.zz, FF, DevRev01	76
01.00.zz, PROFIBUS PA, DevRev01	77
01.00.zz, HART, DevRev01	78

1) Product Configurator, "Firmware version" ordering feature

## Protocol-specific data

## HART

Manufacturer ID	17 (11 hex)
Device Type Code	25 (19 hex)
Device Revision	01 (01 hex) - SW version 01.00.zz
HART specification	6
DD Revision	<ul style="list-style-type: none"> <li>▪ 01 (netherlands)</li> <li>▪ 02 (russian)</li> </ul>
Device description files (DTM, DD)	Information and files can be found: <ul style="list-style-type: none"> <li>▪ www.endress.com</li> <li>▪ www.hartcomm.org</li> </ul>
HART load	Min. 250 Ω
HART device variables	The measured values can be freely assigned to the device variables: <p><b>Measured values for PV (primary variable)</b></p> <ul style="list-style-type: none"> <li>▪ Pressure</li> <li>▪ Level</li> <li>▪ Tank content</li> </ul> <p><b>Measured values for SV, TV (second and third variable)</b></p> <ul style="list-style-type: none"> <li>▪ Pressure</li> <li>▪ Level</li> </ul> <p><b>Measured values for QV (fourth variable)</b></p> <ul style="list-style-type: none"> <li>▪ Temperature</li> </ul>
Supported functions	<ul style="list-style-type: none"> <li>▪ Burst mode</li> <li>▪ Additional Transmitter Status</li> <li>▪ Device Locking</li> <li>▪ Alternative operating modes</li> </ul>

## PROFIBUS PA

Manufacturer ID	17 (11 hex)
Ident number	1554 hex
Profile Version	3.02 <ul style="list-style-type: none"> <li>▪ SW Version 01.00.zz</li> </ul>
GSD Revision	5
DD Revision	1
GSD File	Information and files can be found: <ul style="list-style-type: none"> <li>▪ www.endress.com</li> <li>▪ www.profibus.org</li> </ul>
DD Files	
Output values	<p><b>Measured values for PV (über Analog Input Function Block)</b></p> <ul style="list-style-type: none"> <li>▪ Pressure</li> <li>▪ Flow</li> <li>▪ Level</li> <li>▪ Tank content</li> </ul> <p><b>Measured values for SV</b></p> <ul style="list-style-type: none"> <li>▪ Pressure</li> <li>▪ Temperature</li> </ul>
Input values	Input value sent from PLC, can be shown on display

Supported functions	<ul style="list-style-type: none"> <li>▪ Identification &amp; Maintenance Simple device identification via control system and nameplate</li> <li>▪ Condensed status<sup>1)</sup></li> <li>▪ Automatic ident number adaptation and switchable to following ident numbers<sup>1)</sup>:                         <ul style="list-style-type: none"> <li>- 9700: Profile-specific transmitter identification number with the "Classic" or "Condensed" status".</li> <li>- 151C: Compatibility mode for the old Cerabar M (PMC41, PMC45, PMP41, PMP45, PMP46, PMP48).</li> <li>- 1553: Identification number for the new Cerabar M (PMC51, PMP51, PMP55).</li> </ul> </li> <li>▪ Device locking: The device can be locked by hardware or software.</li> </ul>
---------------------	--

1) Only with Profile Version 3.02

**Data of the FOUNDATION Fieldbus interface**

*Basic data*

Device Type	0x1019
Device Revision	01 (hex)
DD Revision	0x01021
CFR Revision	0x000102
ITK Version	5.2.0
ITK Certification Driver No.	IT067700
Link-Master (LAS) capable	Yes
Link Master / Basic Device selectable	Yes; Factory setting: Basic Device
Number of VCRs	44
Number of Link Objects in VFD	50
Number of FB-Schedule Objects	40

*Virtual communication references (VCRs)*

Permanent Entries	44
Client VCRs	0
Server VCRs	5
Source VCRs	8
Sink VCRs	0
Subscriber VCRs	12
Publisher VCRs	19

*Link settings*

Slot time	4
Min. inter PDU delay	12
Max. response delay	40

*Transducer Blocks*

Block	Content	Output values
TRD1 Block	Contains all parameters related to the measurement	<ul style="list-style-type: none"> <li>■ Pressure or level (channel 1)</li> <li>■ Process temperature (channel 2)</li> <li>■ Measured pressure value (channel 3)</li> <li>■ Max. pressure (channel 4)</li> <li>■ Level before linearization (channel 5)</li> </ul>
Diagnostic Block	Contains diagnostic information	<ul style="list-style-type: none"> <li>■ Error code via DI channels (channel 10 to 15)</li> </ul>
Display Block	Contains parameters to configure the onsite display	No output values

*Function blocks*

Block	Content	Number of blocks	Execution time	Functionality
Resource Block	The Resource Block contains all the data that uniquely identify the device. It is an electronic version of a nameplate of the device.	1		enhanced
Analog Input Block 1 Analog Input Block 2	The AI Block receives the measuring data from the Sensor Block, (selectable via a channel number) and makes the data available to other function blocks at its output. Enhancement: digital outputs for process alarms, fail safe mode.	2	25 ms	enhanced
Digital Input Block	This block contains the discrete data of the Diagnose Block (selectable via a channel number 10 to 15) and provides them for other blocks at the output.	1	20 ms	Standard
Digital Output Block	This block converts the discrete input and thus initiates an action (selectable via a channel number) in the DP Flow Block or in the im TRD1 Block. Channel 20 resets the counter for max. pressure transgressions value and Channel 21 resets the Totalizer.	1	20 ms	Standard
PID Block	The PID Block serves as a proportional-integral-derivative controller and is used almost universally for closed-loop-control in the field including cascade and feedforward. Input IN can be indicated on the display. The selection is performed in the Display Block (DISPLAY_MAIN_LINE_CONTENT).	1	40 ms	Standard
Arithmetic Block	This block is designed to permit simple use of popular measurement math functions. The user does not have to know how to write equations. The math algorithm is selected by name, chosen by the user for the function to be performed.	1	35 ms	Standard
Input Selector Block	The Input Selector Block facilitates the selection of up to four inputs and generates an output based on the configured action. This block normally receives its inputs from AI Blocks. The block performs maximum, minimum, average and 'first good' signal selection. Inputs IN1 to IN4 can be indicated on the display. The selection is performed in the Display Block (DISPLAY_MAIN_LINE_1_CONTENT).	1	30 ms	Standard
Signal Characterizer Block	The Signal Characterizer Block has two sections, each with an output that is a non-linear function of the respective input. The non-linear function is generated by a single look-up table with 21 arbitrary x-y pairs.	1	40 ms	Standard

Block	Content	Number of blocks	Execution time	Functionality
Integrator Block	The Integrator Block integrates a variable as a function of the time or accumulates the counts from a Pulse Input Block. The block may be used as a totalizer that counts up until reset or as a batch totalizer that has a setpoint, where the integrated or accumulated value is compared to pre-trip and trip settings, generating a binary signal when the setpoint is reached.	1	35 ms	Standard

**Additional function block information:**

Instantiate Function Block	YES
Number of instantiate blocks	20

## Power supply

### **▲ WARNING**

#### Incorrect connection can limit electrical safety!

- ▶ When using the measuring device in hazardous areas, installation must comply with the corresponding national standards and regulations and the Safety Instructions or Installation or Control Drawings. → 121 ff, "Safety instructions" and "Installation/Control Drawings" ordering features.
- ▶ All explosion protection data are given in separate documentation which is available upon request. The Ex documentation is provided with all Ex-systems as standard → 121 ff, "Safety instructions" and "Installation/Control Drawings" ordering features.
- ▶ According to IEC/EN61010 a suitable disconnector has to be installed for the device
- ▶ HART: Overvoltage protection HAW569-DA2B for the non-hazardous area, ATEX II 2 (1) Ex ia IIC and IEC Ex ia can be ordered as an option (see "Ordering information" ordering feature).
- ▶ Protective circuits against reverse polarity, HF influences and overvoltage peaks are installed.
- ▶ The digital communication signal is transmitted to the bus via a 2-wire connection. The bus also provides the power supply.

### Terminal assignment

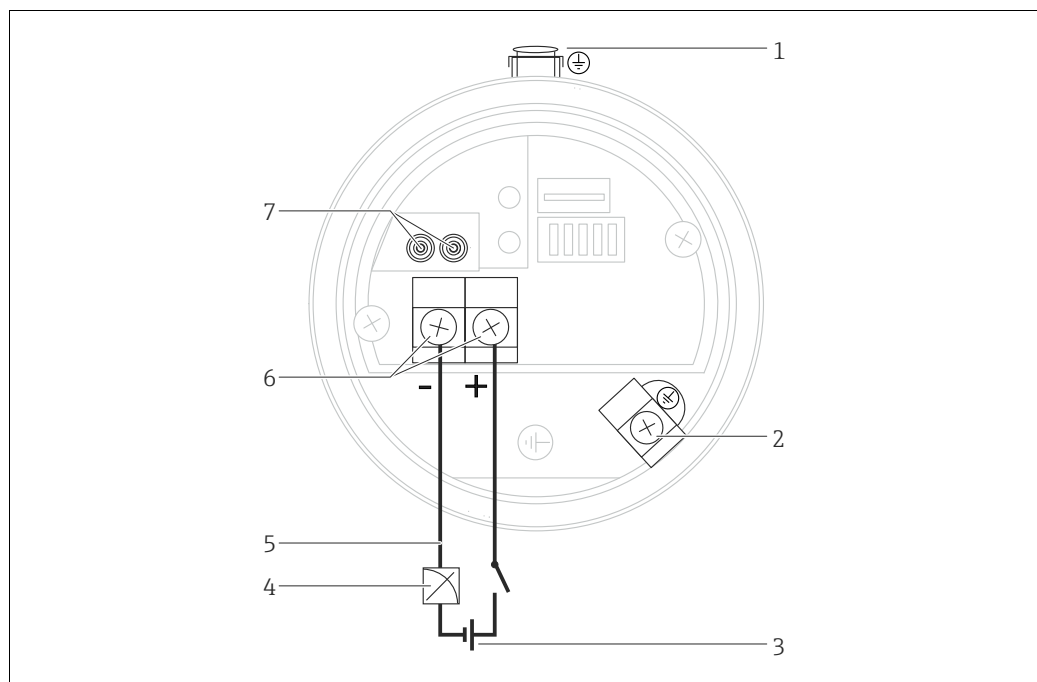

A0023505

#### Electrical connection

- 1 External grounding terminal
- 2 Internal grounding terminal
- 3 Supply voltage → 22
- 4 4...20 mA for HART devices
- 5 For HART and FOUNDATION Fieldbus devices: With a handheld terminal, all the parameters can be configured anywhere along the bus line via menu operation.
- 6 Terminals
- 7 For HART devices: test terminals, see section "Taking 4 to 20 mA test signal"

### Supply voltage

#### 4 to 20 mA HART

Type of protection	Supply voltage
<ul style="list-style-type: none"> <li>▪ Intrinsically safe</li> </ul>	11.5 ... 30 V DC
<ul style="list-style-type: none"> <li>▪ Other types of protection</li> <li>▪ Devices without certificate</li> </ul>	11.5 to 45 V DC (versions with plug-in connection 35 V DC)

#### Taking 4 to 20 mA test signal

A 4 to 20 mA test signal may be measured via the test terminals without interrupting the measurement.

**PROFIBUS PA**

- Version for non-hazardous areas: 9 to 32 V DC

**FOUNDATION Fieldbus**

- Version for non-hazardous areas: 9 to 32 V DC

**Current consumption**

- PROFIBUS PA: 11 mA ± 1 mA, switch-on current corresponds to IEC 61158-2, Clause 21
- FOUNDATION Fieldbus: 16 mA ± 1 mA, switch-on current corresponds to IEC 61158-2, Clause 21

**Electrical connection**

Cable entry	Degree of protection	Option <sup>1)</sup>
M20 gland	IP66/68 NEMA 4X/6P	A
G ½" thread	IP66/68 NEMA 4X/6P	C
NPT ½" thread	IP66/68 NEMA 4X/6P	D
M12 plug	IP66/67 NEMA 4X/6P	I
7/8" plug	IP66/68 NEMA 4X/6P	M
HAN7D connector, 90 deg	IP65	P
PE cable 5m	IP66/68 NEMA4X/6P + pressure compensation via cable	S
M16 valve connector	IP64	V

1) Product Configurator, "Electrical connection" ordering feature

**PROFIBUS PA**

The digital communication signal is transmitted to the bus via a 2-wire connection. The bus also provides the power supply. For further information on the network structure and grounding, and for further bus system components such as bus cables, see the relevant documentation, e.g. Operating Instructions BA00034S "PROFIBUS DP/PA: Guidelines for planning and commissioning" and the PNO Guideline.

**FOUNDATION Fieldbus**

The digital communication signal is transmitted to the bus via a 2-wire connection. The bus also provides the power supply. For further information on the network structure and grounding and for further bus system components such as bus cables, see the relevant documentation, e.g. Operating Instructions BA00013S "FOUNDATION Fieldbus Overview" and the FOUNDATION Fieldbus Guideline.

**Terminals**

- Supply voltage and internal ground terminal: 0.5 ... 2.5 mm<sup>2</sup> (20...14 AWG)
- External ground terminal: 0.5 ... 4 mm<sup>2</sup> (20...14 AWG)

**Cable entry**

Approval	Type	Clamping area
Standard, CSA GP ATEX II1/2G or II2G Ex ia, IEC Ex ia Ga/Gb or Ex ia Gb, FM/ CSA IS	Plastic M20x1.5	5 to 10 mm (0.2 to 0.39 in)
ATEX II1/2D Ex t, II1/2GD Ex ia, II3G Ex nA, IEC Ex t Da/Db	Metal M20x1.5 (Ex e)	7 to 10.5 mm (0.28 to 0.41 in)

For other technical data, see the housing section →  45 ff'.

Connector

Devices with valve connector

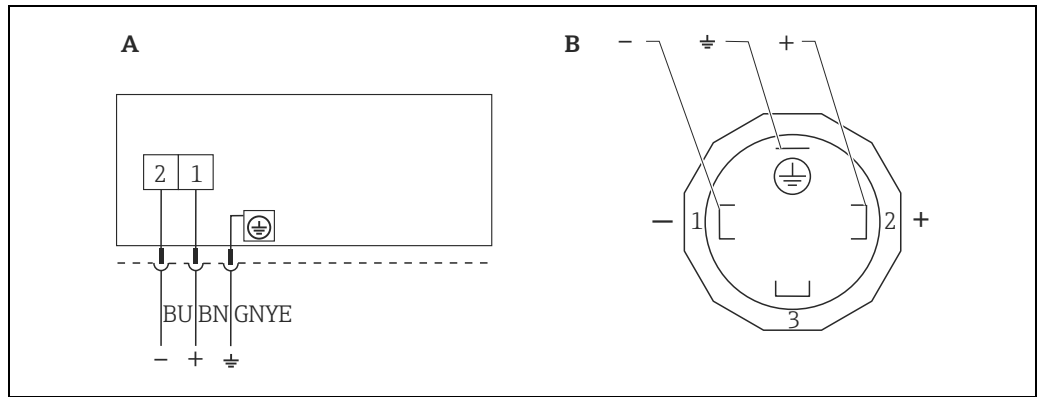

A0023097

BN = brown, BU = blue, GNYE = green/yellow

A Electrical connection for devices with valve connector  
 B View of the connection on the device

Material: PA 6.6

Devices with Harting plug Han7D

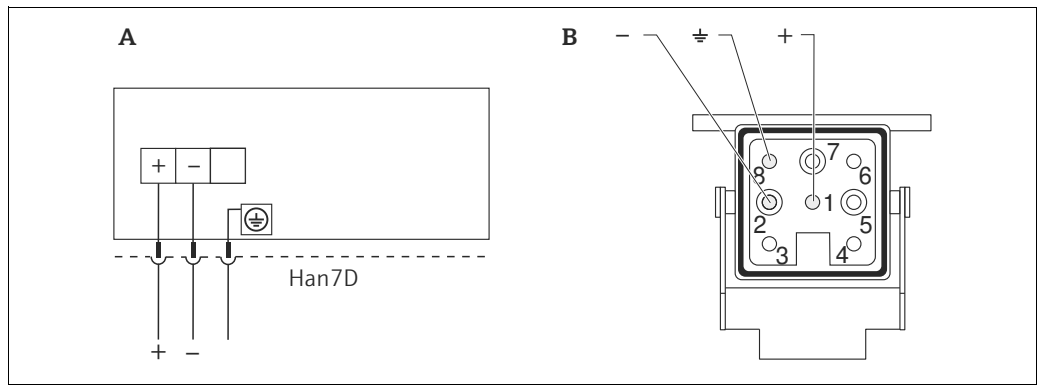

A0019990

A Electrical connection for devices with Harting plug Han7D  
 B View of the connection on the device

Material: CuZn, gold-plated contacts of plug-in jack and connector

Connecting the cable version

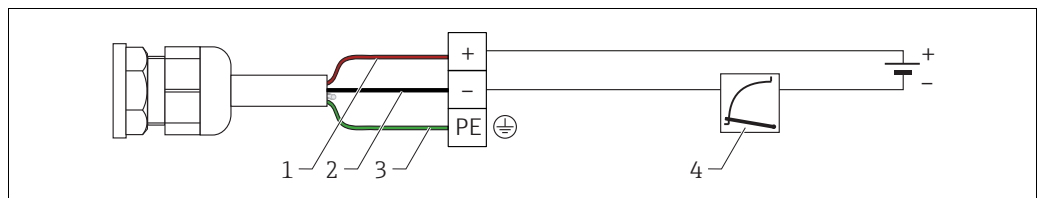

A0019991

1 rd = red  
 2 bk = black  
 3 gnye = green  
 4 4 to 20 mA



**Devices with M12 plug**

*PIN assignment for M12 connector*

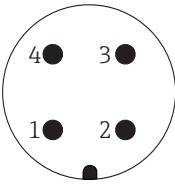
PIN assignment for M12 connector	PIN	Meaning
	1	Signal +
	2	Not assigned
	3	Signal -
	4	Earth

Endress+Hauser offers the following accessories for devices with an M12 plug:

Plug-in jack M 12x1, straight

- Material: body PA; coupling nut CuZn, nickel-plated
- Degree of protection (fully locked): IP66/67
- Order number: 52006263

Plug-in jack M 12x1, elbowed

- Material: body PBT/PA; coupling nut GD-Zn, nickel-plated
- Degree of protection (fully locked): IP66/67
- Order number: 71114212

Cable 4x0.34 mm<sup>2</sup> (20 AWG) with M12 socket, elbowed, screw plug, length 5 m (16 ft)

- Material: body PUR; coupling nut CuSn/Ni; cable PVC
- Degree of protection (fully locked): IP66/67
- Order number: 52010285

**Devices with 7/8" plug**

*PIN assignment for 7/8" connector*

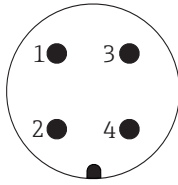
PIN assignment for 7/8" connector	PIN	Meaning
	1	Signal -
	2	Signal +
	3	Not assigned
	4	Shield

External thread: 7/8 - 16 UNC

- Material: 316L (1.4401)
- Protection: IP66/68

**Cable specification**

**HART**

- Endress+Hauser recommends using twisted, shielded two-wire cables.
- The cable outer diameter depends on the cable entry used.

**PROFIBUS PA**

Use a twisted, shielded two-wire cable, preferably cable type A



For further information on the cable specifications, see Operating Instructions BA00034S "PROFIBUS DP/PA: Guidelines for planning and commissioning", the PNO Guideline 2.092 PROFIBUS PA User and Installation Guideline" and IEC 61158-2 (MBP).

**FOUNDATION Fieldbus**

Use a twisted, shielded two-wire cable, preferably cable type A



For further information on the cable specifications, see Operating Instructions BA00013S "FOUNDATION Fieldbus Overview", FOUNDATION Fieldbus Guideline and IEC 61158-2 (MBP).

<b>Start-up current</b>	<ul style="list-style-type: none"> <li>■ Analog electronics: 12 mA</li> <li>■ HART: 12 mA or 22 mA (selectable)</li> </ul>
<b>Residual ripple</b>	No influence on 4 to 20 mA signal up to $\pm 5\%$ residual ripple within the permitted voltage range [according to HART hardware specification HCF_SPEC-54 (DIN IEC 60381-1)]
<b>Influence of power supply</b>	$\leq 0.001\%$ of URL/V
<b>Overvoltage protection (optional)</b>	<p>The device can be fitted with overvoltage protection. The overvoltage protection is mounted at the factory on the housing thread (M20x1.5) for the cable gland and is approx. 70 mm (2.76 in) in length (take additional length into account when installing). The device is connected as illustrated in the following graphic.</p> <p>For details refer to TI01013KEN, XA01003KA3 and BA00304KA2.</p> <p>Ordering information: Product Configurator, "Mounted accessories" ordering feature, option NA</p>

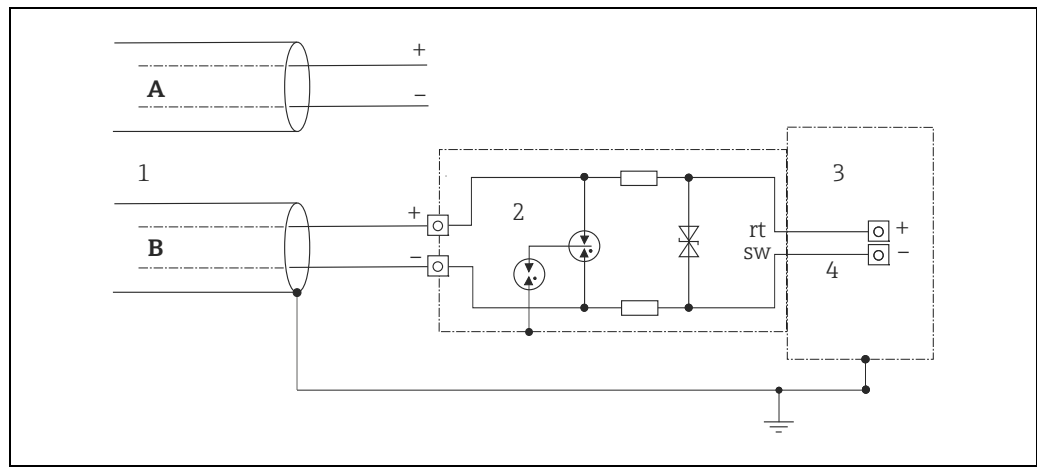

- A Without direct shield grounding
- B With direct shield grounding
- 1 Incoming connection cable
- 2 HAW569-DA2B
- 3 Unit to be protected
- 4 Connection cable

## Performance characteristics of the ceramic process isolating diaphragm

### Reference operating conditions

- As per IEC 60770
- Ambient temperature  $T_A$  = constant, in the range of: +21 to +33 °C (+70 to +91°F)
- Humidity  $\varphi$  = constant, in the range of: 5 to 80 % RH
- Ambient pressure  $p_A$  = constant, in the range of: 860 to 1060 mbar (12.47 to 15.37 psi)
- Position of the measuring cell: constant, in range:  $\pm 1^\circ$  horizontally
- Input of LOW SENSOR TRIM and HIGH SENSOR TRIM for lower range value and upper range value
- Span based on zero point
- Material of the process isolating diaphragm:  $Al_2O_3$  aluminum oxide ceramic FDA, ultrapure 99.9 %
- Supply voltage: 24 V DC  $\pm$  3 V DC
- Load with HART: 250  $\Omega$

### Influence of orientation

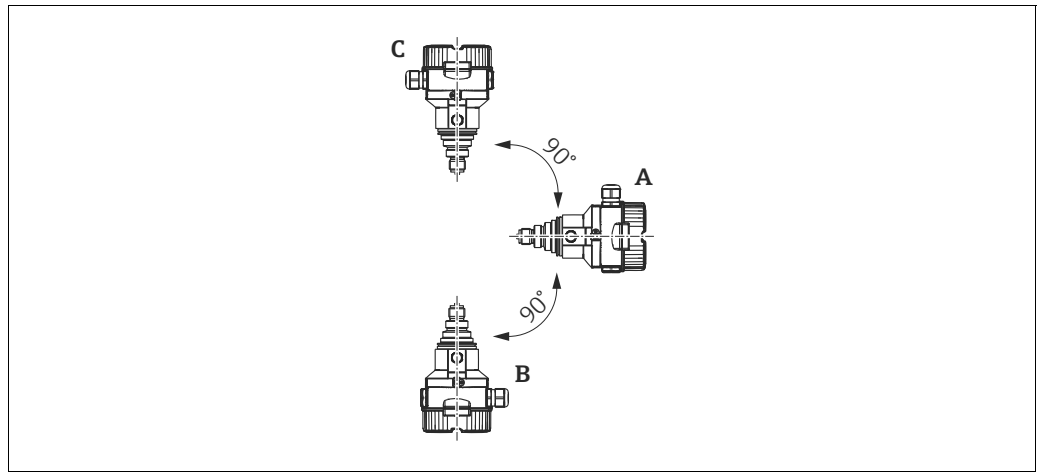

A0023697

### Measuring error in mbar (psi)

Process isolating diaphragm axis is horizontal (A)	Process isolating diaphragm pointing upwards (B)	Process isolating diaphragm pointing downwards (C)
Calibration position, no measuring error	< +0.2 mbar (0.003 psi)	< -0.2 mbar (0.003 psi)



Position-dependent zero point shift can be corrected at the device. → 36, "General installation instructions" ordering feature and → 110 ff, "Installation instructions" ordering feature.

### Uncertainty of measurement for small absolute pressure ranges

- The smallest expanded uncertainty of measurement that can be returned by our standards is:
- 0.4% of the measured value in the range of 1 to 30 mbar
  - 1% of the measured value in the range < 1 mbar.

**Reference accuracy – PMC51**

The reference accuracy comprises the non-linearity according to limit point setting, hysteresis and non-reproducibility as per IEC 60770. The data refer to the calibrated span.

Gauge pressure sensors		
Measuring cell	Standard reference accuracy	Platinum reference accuracy
100 mbar (1.5 psi)	<ul style="list-style-type: none"> <li>▪ TD 1:1 to ≤ TD 10:1 = ±0.15 %</li> <li>▪ TD &gt; 10:1 to TD 20:1 = ±0.2 %</li> </ul>	<ul style="list-style-type: none"> <li>▪ TD 1:1 to ≤ TD 10:1 = ±0.075 %</li> <li>▪ TD &gt; 10:1 to TD 20:1 = ±0.0075 x TD</li> </ul>
250 mbar (3.75 psi), 400 mbar (6 psi), 1 bar (15 psi), 2 bar (30 psi), 4 bar (60 psi), 10 bar (150 psi)	<ul style="list-style-type: none"> <li>▪ TD 1:1 to ≤ TD 10:1 = ±0.15 %</li> <li>▪ TD &gt; 10:1 to TD 20:1 = ±0.2 %</li> </ul>	<ul style="list-style-type: none"> <li>▪ TD 1:1 to ≤ TD 10:1 = ±0.075 %</li> <li>▪ TD &gt; 10:1 to TD 20:1 = ±0.1 %</li> </ul>
40 bar (600 psi)	<ul style="list-style-type: none"> <li>▪ TD 1:1 to ≤ TD 10:1 = ±0.15 %</li> <li>▪ TD &gt; 10:1 to TD 20:1 = ±0.2 %</li> </ul>	<ul style="list-style-type: none"> <li>▪ TD 1:1 to ≤ TD 10:1 = ±0.075 %</li> <li>▪ TD &gt; 10:1 to TD 20:1 = ±0.0075 x TD</li> </ul>

Absolute pressure sensors		
Measuring cell	Standard reference accuracy	Platinum reference accuracy
100 mbar (1.5 psi)	<ul style="list-style-type: none"> <li>▪ TD 1:1 to ≤ TD 10:1 = ±0.15 %</li> <li>▪ TD &gt; 10:1 to TD 20:1 = ±0.015 x TD</li> </ul>	<ul style="list-style-type: none"> <li>▪ TD 1:1 to TD 5:1 = ±0.075 %</li> <li>▪ TD &gt; 5:1 to TD 20:1 = ±0.015 x TD</li> </ul>
250 mbar (3.75 psi)	<ul style="list-style-type: none"> <li>▪ TD 1:1 to ≤ TD 10:1 = ±0.15 %</li> <li>▪ TD &gt; 10:1 to TD 20:1 = ±0.2 %</li> </ul>	<ul style="list-style-type: none"> <li>▪ TD 1:1 to ≤ TD 10:1 = ±0.075 %</li> <li>▪ TD &gt; 10:1 to TD 13:1 = ±0.1 %</li> </ul>
400 mbar (6 psi), 1 bar (15 psi), 2 bar (30 psi), 4 bar (60 psi), 10 bar (150 psi)	<ul style="list-style-type: none"> <li>▪ TD 1:1 to ≤ TD 10:1 = ±0.15 %</li> <li>▪ TD &gt; 10:1 to TD 20:1 = ±0.2 %</li> </ul>	<ul style="list-style-type: none"> <li>▪ TD 1:1 to ≤ TD 10:1 = ±0.075 %</li> <li>▪ TD &gt; 10:1 to TD 20:1 = ±0.1 %</li> </ul>
40 bar (600 psi)	<ul style="list-style-type: none"> <li>▪ TD 1:1 to ≤ TD 10:1 = ±0.15 %</li> <li>▪ TD &gt; 10:1 to TD 20:1 = ±0.2 %</li> </ul>	<ul style="list-style-type: none"> <li>▪ TD 1:1 to ≤ TD 10:1 = ±0.075 %</li> <li>▪ TD &gt; 10:1 to TD 20:1 = ±0.0075 x TD</li> </ul>

**Thermal change in the zero output and the output span – PMC51**
**PMC51 with thread or flange**

Signal output	Measuring cell	% of the calibrated measuring span		
		-40 to -20 °C (-40 to -4°F)	-10 to +60 °C (+14 to +140°F)	-20 to +100 °C (-4 to +212°F)
HART, PROFIBUS PA, FOUNDATION Fieldbus	100 mbar (1.5 psi), 250 mbar (3.75 psi), 400 mbar (6 psi)	±(0.6 + 0.45 x TD)	±0.2 + 0.275 x TD	±(0.4 + 0.425 x TD)
	1 bar (15 psi), 2 bar (30 psi), 4 bar (60 psi), 10 bar (150 psi), 40 bar (600 psi)	±0.5 + 0.35 x TD	±0.1 + 0.15 x TD	±(0.225 + 0.525 x TD)
Analog (4 to 20 mA)	100 mbar (1.5 psi), 250 mbar (3.75 psi), 400 mbar (6 psi)	±(0.6 + 0.45 x TD)	±0.4 + 0.275 x TD	±0.7 + 0.425 x TD
	1 bar (15 psi), 2 bar (30 psi), 4 bar (60 psi), 10 bar (150 psi), 40 bar (600 psi)	±0.5 + 0.35 x TD	±0.3 + 0.15 x TD	±0.525 + 0.525 x TD

**PMC51 with hygienic process connection**

Signal output	Measuring cell	% of the calibrated measuring span	
		-10 to +60 °C (+14 to +140°F)	-20 to +130 °C (-4 to +266°F)
HART, PROFIBUS PA, FOUNDATION Fieldbus	100 mbar (1.5 psi), 250 mbar (3.75 psi), 400 mbar (6 psi)	±(0.4 + 0.275 x TD)	±(0.7 + 0.425 x TD)
	1 bar (15 psi), 2 bar (30 psi), 4 bar (60 psi), 10 bar (150 psi), 40 bar (600 psi)	±(0.3 + 0.15 x TD)	±(0.525 + 0.525 x TD)
Analog (4 to 20 mA)	100 mbar (1.5 psi), 250 mbar (3.75 psi), 400 mbar (6 psi)	±(0.4 + 0.275 x TD)	±(0.7 + 0.425 x TD)
	1 bar (15 psi), 2 bar (30 psi), 4 bar (60 psi), 10 bar (150 psi), 40 bar (600 psi)	±(0.3 + 0.15 x TD)	±(0.525 + 0.525 x TD)

**Total performance – PMC51**

The "Total performance" specification comprises the non-linearity including hysteresis, non-reproducibility as well as the thermal change in the zero point. All specifications apply to the temperature range -10 to +60 °C (+14 to +140°F) and Turndown 1:1.

Signal output	Measuring cell	% URL
HART, PROFIBUS PA, FOUNDATION Fieldbus	100 mbar (1.5 psi), 250 mbar (3.75 psi), 400 mbar (6 psi)	±0.575
	1 bar (15 psi), 2 bar (30 psi), 4 bar (60 psi), 10 bar (150 psi), 40 bar (600 psi)	±0.5
Analog (4 to 20 mA)	100 mbar (1.5 psi), 250 mbar (3.75 psi), 400 mbar (6 psi)	±0.775
	1 bar (15 psi), 2 bar (30 psi), 4 bar (60 psi), 10 bar (150 psi), 40 bar (600 psi)	±0.7

**Long-term stability**

**For devices with thread or flange:**

Measuring range	Long-term stability of URL / 1 year	Long-term stability of URL / 5 years	Long-term stability of URL / 10 years
≤ 1 bar (15 psi)	±0.2 %	±0.4 %	±0.5 %
> 1 bar (15 psi)	±0.1 %	±0.25 %	±0.4 %

**For devices with hygienic process connections:**

Measuring range	Long-term stability of URL / 1 year
≤ 1 bar (15 psi)	±0.35 %
> 1 bar (15 psi)	±0.2 %

**Total error - PMC51**

The total error comprises the long-term stability and the total performance. All specifications apply to the temperature range  $-10$  to  $+60$  °C ( $+14$  to  $+140$  °F) and Turndown 1:1.

	Signal output	Measuring cell	% URL
			1 year
PMC51 with thread or flange	HART, PROFIBUS PA, FOUNDATION Fieldbus	100 mbar (1.5 psi), 250 mbar (3.75 psi), 400 mbar (6 psi)	±0.55
		1 bar (15 psi), 2 bar (30 psi), 4 bar (60 psi), 10 bar (150 psi), 40 bar (600 psi)	±0.47
	Analog (4 to 20 mA)	100 mbar (1.5 psi), 250 mbar (3.75 psi), 400 mbar (6 psi)	±0.75
		1 bar (15 psi), 2 bar (30 psi), 4 bar (60 psi), 10 bar (150 psi), 40 bar (600 psi)	±0.67
PMC51 with hygienic process connection	HART, PROFIBUS PA, FOUNDATION Fieldbus	100 mbar (1.5 psi), 250 mbar (3.75 psi), 400 mbar (6 psi)	±0.925
		1 bar (15 psi), 2 bar (30 psi), 4 bar (60 psi), 10 bar (150 psi), 40 bar (600 psi)	±0.7
	Analog (4 to 20 mA)	100 mbar (1.5 psi), 250 mbar (3.75 psi), 400 mbar (6 psi)	±1.125
		1 bar (15 psi), 2 bar (30 psi), 4 bar (60 psi), 10 bar (150 psi), 40 bar (600 psi)	±0.9

**Warm-up period**

- 4 to 20 mA analog:  $\leq 1.5$  s
- 4 to 20 mA HART:  $\leq 5$  s
- PROFIBUS PA:  $\leq 8$  s
- FOUNDATION Fieldbus:  $\leq 20$  s (after a TOTAL-reset  $\leq 45$  s)

## Performance characteristics of the metallic process isolating diaphragm

### Reference operating conditions

- As per IEC 60770
- Ambient temperature  $T_A$  = constant, in the range of: +21 to +33 °C (+70 to +91°F)
- Humidity  $\phi$  = constant, in the range of: 5 to 80 % RH
- Ambient pressure  $p_A$  = constant, in the range of: 860 to 1060 mbar (12.47 to 15.37 psi)
- Position of the measuring cell: constant, in range:  $\pm 1^\circ$  horizontally
- Input of LOW SENSOR TRIM and HIGH SENSOR TRIM for lower range value and upper range value
- Span based on zero point
- Material of the process isolating diaphragm: AISI 316L
- Filling oil: NSF-H1 synthetisk oil according to FDA 21 CFR 178.3570
- Supply voltage: 24 V DC  $\pm$  3 V DC
- Load with HART: 250  $\Omega$

### Influence of orientation

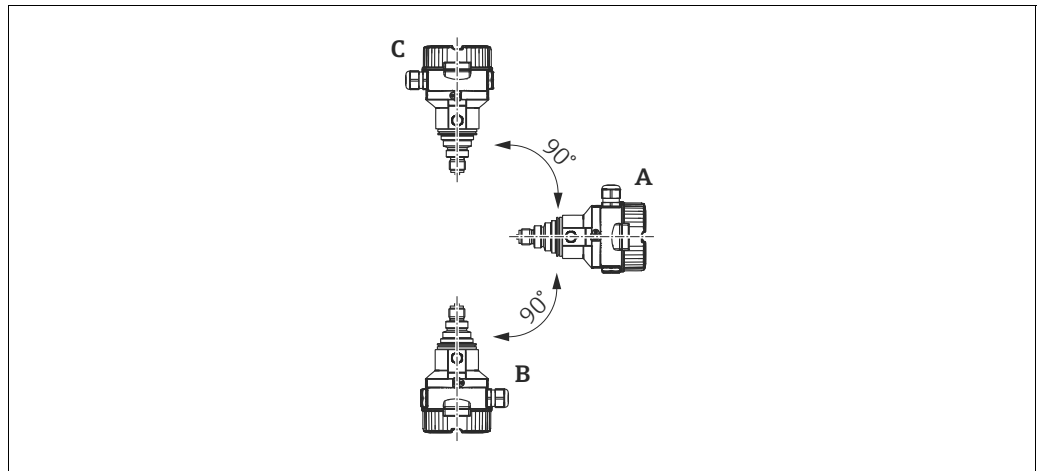

Measuring error in mbar (psi)

	Process isolating diaphragm axis is horizontal (A)	Process isolating diaphragm pointing upwards (B)	Process isolating diaphragm pointing downwards (C)
PMP51 with process connections 1/2" thread and Silicone oil	Calibration position, no measuring error	< +4 mbar (0.06 psi)	< -4 mbar (0.06 psi)
PMP51 with process connections > thread 1/2" and flanges		< +10 mbar (0.145 psi) This value is doubled for inert oil.	< -10 mbar (0.145 psi) This value is doubled for inert oil.



Position-dependent zero point shift can be corrected at the device. → 36, "General installation instructions" ordering feature and → 110 ff, "Installation instructions" ordering feature.

### Uncertainty of measurement for small absolute pressure ranges

- The smallest expanded uncertainty of measurement that can be returned by our standards is:
- 0.4% of the measured value in the range of 1 to 30 mbar
  - 1% of the measured value in the range < 1 mbar.

**Reference accuracy –  
PMP51, PMP55**

The reference accuracy comprises the non-linearity according to limit point setting, hysteresis and non-reproducibility as per IEC 60770. The data refer to the calibrated span.

**Gauge pressure sensors/absolute pressure sensors**

Measuring cell	PMP51 and PMP55 without capillary	
	Standard reference accuracy	Platinum reference accuracy <sup>1)</sup>
400 mbar (6 psi)	<ul style="list-style-type: none"> <li>▪ TD 1:1 = ±0.15 %</li> <li>▪ TD &gt;1:1 to TD 20:1 = ±0.15 % x TD</li> </ul>	Not available
	PMP51 with hygienic process connection: <ul style="list-style-type: none"> <li>▪ TD 1:1 = ±0.3 %</li> <li>▪ TD &gt;1:1 to TD 10:1 = ±0.3 % x TD</li> </ul>	Not available
1 bar (15 psi)	<ul style="list-style-type: none"> <li>▪ TD 1:1 to TD 5:1 = ±0.15 %</li> <li>▪ TD &gt;5:1 to TD 20:1 = ±0.03 % x TD</li> </ul>	<ul style="list-style-type: none"> <li>▪ TD 1:1 to TD 2.5:1 = ±0.075 %</li> <li>▪ TD &gt;2.5:1 to TD 20:1 = ±0.03 % x TD</li> </ul>
	PMP51 with hygienic process connection: <ul style="list-style-type: none"> <li>▪ TD 1:1 = ±0.3 %</li> <li>▪ TD &gt;1:1 to TD 10:1 = ±0.3 % x TD</li> </ul>	PMP51 with hygienic process connection: <ul style="list-style-type: none"> <li>▪ TD 1:1 = ±0.2 %</li> <li>▪ TD &gt;1:1 to TD 10:1 = ±0.2 % x TD</li> </ul>
2 bar (30 psi)	<ul style="list-style-type: none"> <li>▪ TD 1:1 to TD 10:1 = ±0.15 %</li> <li>▪ TD &gt;10:1 to TD 20:1 = ±0.015 % x TD</li> </ul>	<ul style="list-style-type: none"> <li>▪ TD 1:1 to TD 5:1 = ±0.075 %</li> <li>▪ TD &gt;5:1 to TD 20:1 = ±0.015 % x TD</li> </ul>
	PMP51 with hygienic process connection: <ul style="list-style-type: none"> <li>▪ TD 1:1 to TD ≤5:1 = ±0.15 %</li> <li>▪ TD &gt;5:1 to TD ≤10:1 = ±0.2 %</li> </ul>	PMP51 with hygienic process connection: <ul style="list-style-type: none"> <li>▪ TD 1:1 to TD ≤5:1 = ±0.075 %</li> <li>▪ TD &gt;5:1 to TD ≤10:1 = ±0.1 %</li> </ul>
4 bar (60 psi)	<ul style="list-style-type: none"> <li>▪ TD 1:1 to TD 10:1 = ±0.15 %</li> <li>▪ TD &gt;10:1 to TD 20:1 = ±0.2 %</li> </ul>	<ul style="list-style-type: none"> <li>▪ TD 1:1 to TD 10:1 = ±0.075 %</li> <li>▪ TD 10:1 to TD 20:1 = ±0.0075 % x TD</li> </ul>
	PMP51 with hygienic process connection: <ul style="list-style-type: none"> <li>▪ TD 1:1 to TD ≤10:1 = ±0.15 %</li> <li>▪ TD &gt;10:1 to TD 20:1 = ±0.2 %</li> </ul>	PMP51 with hygienic process connection: <ul style="list-style-type: none"> <li>▪ TD 1:1 to TD ≤10:1 = ±0.075 %</li> <li>▪ TD &gt;10:1 to TD 20:1 = ±0.1 %</li> </ul>
10 bar (150 psi), 40 bar (600 psi)	<ul style="list-style-type: none"> <li>▪ TD 1:1 to TD 10:1 = ±0.15 %</li> <li>▪ TD &gt;10:1 to TD 20:1 = ±0.2 %</li> </ul>	<ul style="list-style-type: none"> <li>▪ TD 1:1 to TD 10:1 = ±0.075 %</li> <li>▪ TD 10:1 to TD 20:1 = ±0.1 %</li> </ul>
	PMP51 with hygienic process connection: <ul style="list-style-type: none"> <li>▪ TD 1:1 to TD ≤10:1 = ±0.15 %</li> <li>▪ TD &gt;10:1 to TD 20:1 = ±0.2 %</li> </ul>	PMP51 with hygienic process connection: <ul style="list-style-type: none"> <li>▪ TD 1:1 to TD ≤10:1 = ±0.075 %</li> <li>▪ TD &gt;10:1 to TD 20:1 = ±0.1 %</li> </ul>
100 bar (1500 psi)	<ul style="list-style-type: none"> <li>▪ TD 1:1 to TD 10:1 = ±0.15 %</li> <li>▪ TD &gt;10:1 to TD 20:1 = ±0.2 %</li> </ul>	<ul style="list-style-type: none"> <li>▪ TD 1:1 to TD 10:1 = ±0.075 %</li> <li>▪ TD 10:1 to TD 20:1 = ±0.15 %</li> </ul>
400 bar (6000 psi)	<ul style="list-style-type: none"> <li>▪ TD 1:1 to TD 5:1 = ±0.15 %</li> <li>▪ TD &gt;5:1 to TD 20:1 = ±(0.03 % x TD)</li> </ul>	<ul style="list-style-type: none"> <li>▪ TD 1:1 to TD 5:1 = ±0.15 %</li> <li>▪ TD &gt;5:1 to TD 20:1 = ±(0.03 % x TD)</li> </ul>

1) Only PMP51, PMP55 with direct diaphragm seal mounting

**Gauge pressure sensors/absolute pressure sensors**

Measuring cell	PMP55 with capillary
400 mbar (6 psi)	<ul style="list-style-type: none"> <li>▪ TD 1:1 = ±0.15 %</li> <li>▪ TD &gt;1:1 to TD 20:1 = ±0.15 % x TD</li> </ul>
1 bar (15 psi)	<ul style="list-style-type: none"> <li>▪ TD 1:1 to TD 3.75:1 = ±0.15 %</li> <li>▪ TD &gt;3.75:1 to TD 20:1 = ±0.04 % x TD</li> </ul>
2 bar (30 psi)	<ul style="list-style-type: none"> <li>▪ TD 1:1 to TD 3.75:1 = ±0.15 %</li> <li>▪ TD &gt;3.75:1 to TD 20:1 = ±0.04 % x TD</li> </ul>
4 bar (60 psi)	<ul style="list-style-type: none"> <li>▪ TD 1:1 to TD 10:1 = ±0.15 %</li> <li>▪ TD &gt;10:1 to TD 20:1 = ±0.2 %</li> </ul>
10 bar (150 psi), 40 bar (600 psi)	<ul style="list-style-type: none"> <li>▪ TD 1:1 to TD 10:1 = ±0.15 %</li> <li>▪ TD &gt;10:1 to TD 20:1 = ±0.2 %</li> </ul>
100 bar (1500 psi)	<ul style="list-style-type: none"> <li>▪ TD 1:1 to TD 10:1 = ±0.15 %</li> <li>▪ TD &gt;10:1 to TD 20:1 = ±0.2 %</li> </ul>
400 bar (6000 psi)	<ul style="list-style-type: none"> <li>▪ TD 1:1 to TD 5:1 = ±0.15 %</li> <li>▪ TD &gt;5:1 to TD 20:1 = ±(0.03 % x TD)</li> </ul>



**Thermal change in the zero output and the output span – PMP51 and PMP55**



When using a PMP55, the influence from the respective diaphragm seal must also be taken into account (→ 107 ff "Planning instructions for diaphragm seal systems").

**PMP51 and PMP55 (basic device)**

Measuring cell	-10 to +60 °C (+14 to +140°F)	-40 to -10 °C, +60 to +85 °C (-40 to +14°F, +140 to +185°F)
	% of the calibrated measuring span	
400 mbar (6 psi), 1 bar (15 psi), 2 bar (30 psi), 4 bar (60 psi), 10 bar (150 psi), 40 bar (600 psi), 100 bar (1500 psi)	$\pm(0.34 + 0.15 \times \text{TD})$	$\pm(0.4 + 0.25 \times \text{TD})$
400 bar (6000 psi)	$\pm(0.3 + 0.35 \times \text{TD})$	$\pm(0.3 + 0.7 \times \text{TD})$

**PMP51 with hygienic process connection**

Signal output	Measuring cell	-10 to +60 °C (+14 to +140°F)	-40 to -10 °C, +60 to +125 °C (-40 to +14°F, +140 to +257°F)
		% of the calibrated measuring span	
HART, PROFIBUS PA, FOUNDATION Fieldbus	Clamp 1/2" / 400 mbar (6 psi)	$\pm(0.1 + 0.4 \times \text{TD})$	$\pm(0.8 + 1.5 \times \text{TD})$
	400 mbar (6 psi), 1 bar (15 psi)	$\pm(0.1 + 0.25 \times \text{TD})$	$\pm(0.1 + 1.1 \times \text{TD})$
	2 bar (30 psi), 4 bar (60 psi), 10 bar (150 psi), 40 bar (600 psi)	$\pm(0.1 + 0.2 \times \text{TD})$	$\pm(0.1 + 0.5 \times \text{TD})$
Analog (4 to 20 mA)	Clamp 1/2" / 400 mbar (6 psi)	$\pm(0.3 + 0.4 \times \text{TD})$	$\pm(1.1 + 1.5 \times \text{TD})$
	400 mbar (6 psi), 1 bar (15 psi)	$\pm(0.3 + 0.25 \times \text{TD})$	$\pm(0.4 + 1.1 \times \text{TD})$
	2 bar (30 psi), 4 bar (60 psi), 10 bar (150 psi), 40 bar (600 psi)	$\pm(0.3 + 0.2 \times \text{TD})$	$\pm(0.4 + 0.5 \times \text{TD})$

**Total performance – PMP51**

The "Total performance" specification comprises the non-linearity including hysteresis, non-reproducibility as well as the thermal change in the zero point. All specifications apply to the temperature range -10 to +60 °C (+14 to +140°F) and Turndown 1:1.

Signal output	Measuring cell	PMP51	PMP51 with hygienic process connection	PMP51 with gold/rhodium-coated process isolating diaphragm
		% of URL		
HART, PROFIBUS PA, FOUNDATION Fieldbus	400 mbar (6 psi)	±0.34	±0.34	±1.25
	1 bar (15 psi)		±0.25	±0.75
	2 bar (30 psi)		±0.25	±0.45
	4 bar (60 psi)	±0.30	±0.25	±0.3
	10 bar (150 psi), 40 bar (600 psi)	±0.25	±0.25	±0.25
	100 bar (1500 psi)	±0.25	-	±0.25
	400 bar (6000 psi)	±0.4	-	±0.4
Analog (4 to 20 mA)	400 mbar (6 psi)	±0.34	±0.54	±1.25
	1 bar (15 psi)		±0.54	±0.75
	2 bar (30 psi)		±0.45	±0.45
	4 bar (60 psi)	±0.30	±0.45	±0.3
	10 bar (150 psi), 40 bar (600 psi)	±0.25	±0.45	±0.25
	100 bar (1500 psi)	±0.25	-	±0.25
	400 bar (6000 psi)	±0.4	-	±0.4

**Long-term stability**

**For devices with thread or flange:**

	Measuring range	Long-term stability of URL / 1 year	Long-term stability of URL / 5 years	Long-term stability of URL / 10 years
<b>PMP51</b>	all	±0.1 %	±0.2 %	±0.25 %
<b>PMP55</b>	all	To determine long-term stability, the basic device (PMP51) is observed without the attached diaphragm seal.		

**For devices with hygienic process connections:**

	Measuring range	Long-term stability of URL / 1 year
<b>PMP51</b>	≤ 1 bar (15 psi)	±0.25 %
	> 1 bar...10 bar (15...150 psi)	±0.1 %
	40 bar (600 psi)	±0.1 %
	100 bar (1500 psi)	±0.1 %
	400 bar (6000 psi)	±0.1 %

**Total error - PMP51**

The total error comprises the long-term stability and the total performance. All specifications apply to the temperature range -10 to +60 °C (+14 to +140°F) and Turndown 1:1.

Signal output	Measuring cell	% of URL/year
HART, PROFIBUS PA, FOUNDATION Fieldbus	400 mbar (6 psi)	±0.59
	≥1 bar to 40 bar (15 psi to 600 psi)	±0.35
	≥40 bar to 100 bar (600 psi to 1500 psi)	±0.35
	400 bar (6000 psi)	±0.5
Analog (4 to 20 mA)	400 mbar (6 psi)	±0.79
	≥1 bar to 40 bar (15 psi to 600 psi)	±0.55
	≥40 bar to 100 bar (600 psi to 1500 psi)	±0.55
	400 bar (6000 psi)	±0.5

---

**Warm-up period**

- 4 to 20 mA analog: ≤1.5 s
- 4 to 20 mA HART: ≤5 s
- PROFIBUS PA: ≤8 s
- FOUNDATION Fieldbus: ≤20 s (after a TOTAL-reset ≤45 s)

## Installation

### General installation instructions

- The position-dependent zero point shift can be corrected:
  - directly at the device via operating keys on the electronic insert
  - directly at the device via operating keys on the display (except analog electronics)
  - via digital communication if the cover is not open (except analog electronics)

#### **▲ WARNING**

##### **Risk of explosion!**

In hazardous areas, comply strictly with the safety instructions when the housing cover is closed and open.

- Endress+Hauser offers a mounting bracket for installing the device on pipes or walls, see also →  37, "Wall and pipe mounting, transmitter (optional)" ordering feature.
- Use flushing rings for flange and cell diaphragm seals if medium buildup or clogging can be expected at the diaphragm seal connection. The flushing ring can be inserted between the process connection and the diaphragm seal. Thanks to the two lateral flushing bore holes, material buildup in front of the process isolating diaphragm can be rinsed away and the pressure chamber can be ventilated.
- To guarantee the leak-tightness of the transmitter, Endress+Hauser recommends that only genuine cable glands be used (also available as spare parts).

### Measuring arrangement for devices without diaphragm seal – PMC51, PMP51

Cerabar M transmitters without diaphragm seals are mounted as per the norms for a manometer (DIN EN 837-2). We recommend the use of shutoff devices and siphons. The orientation depends on the measuring application.

#### **Pressure measurement in gases**

Mount Cerabar M with shutoff device above the tapping point so that any condensate can flow into the process.

#### **Pressure measurement in steams**

- Use a siphon if measuring pressure in steams. The siphon reduces the temperature to almost the ambient temperature. Preferably mount the Cerabar M with a siphon below the tapping point.
 

Advantages:

  - Defined water column only causes minimal/negligible measured errors
  - Only minimal/negligible thermal effects on the device

The device may also be mounted above the tapping point. Pay attention to the maximum permitted ambient temperature of the transmitter!
- Fill the siphon with liquid before commissioning.

#### **Pressure measurement in liquids**

Mount Cerabar M with shutoff device below or at the same level as the tapping point.

#### **Level measurement**

- Mount Cerabar M below the lowest measuring point (zero point of the measurement).
- Do not mount the device at the following positions: In the filling curtain, in the tank outlet or at a point in the vessel which could be affected by pressure pulses from an agitator or a pump.
- The calibration and functional test can be carried out more easily if you mount the device downstream of a shutoff device.

### Measuring arrangement for devices with diaphragm seal – PMP55

→  107, section "Planning instructions for diaphragm seal systems".

**Wall and pipe mounting, transmitter (optional)**

Endress+Hauser offers the following mounting bracket for installing the device on pipes or walls:

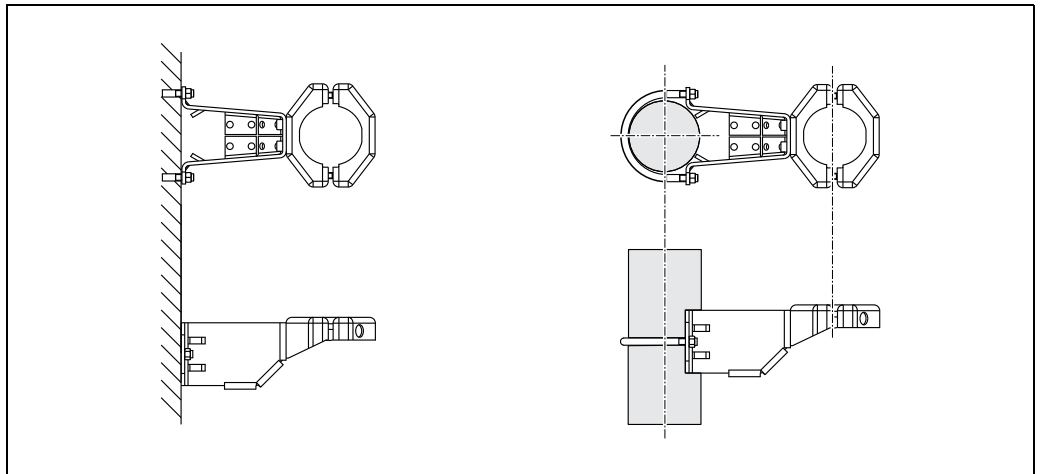

Engineering unit mm (in)

A0032492

Ordering information:

- Product configurator "Accessory Enclosed" ordering feature, option PA.
- included in the delivery for devices with a separate housing (available for order via feature "Separate housing")
- available for order as a separate accessory (Part No.: 71102216).
- Further details, see → 93.

**Wall and pipe mounting manifold (optional)**



Engineering unit (in)

A0030607

Ordering information:

Product configurator "Accessory Enclosed" ordering feature, option PK.  
 Technical data see see accessory document SD01553P/00/EN.

**"Separate housing" version**

With the "separate housing" version, you are able to mount the housing with the electronics insert at a distance from the measuring point. This version allows for trouble-free measurement:

- Under particularly difficult measuring conditions (at installation locations that are cramped or difficult to access)
- If quick cleaning of the measuring point is required
- If the measuring point is exposed to vibrations

You can choose between different cable versions:

- PE (2 m (6.6 ft), 5 m (16 ft) and 10 m (33 ft))
- FEP (5 m (16 ft)).

Ordering information:

Product Configurator, "Separate housing" ordering feature or

Product Configurator, "Enclosed accessories" ordering feature, option PA

For the dimensions, see →  93.

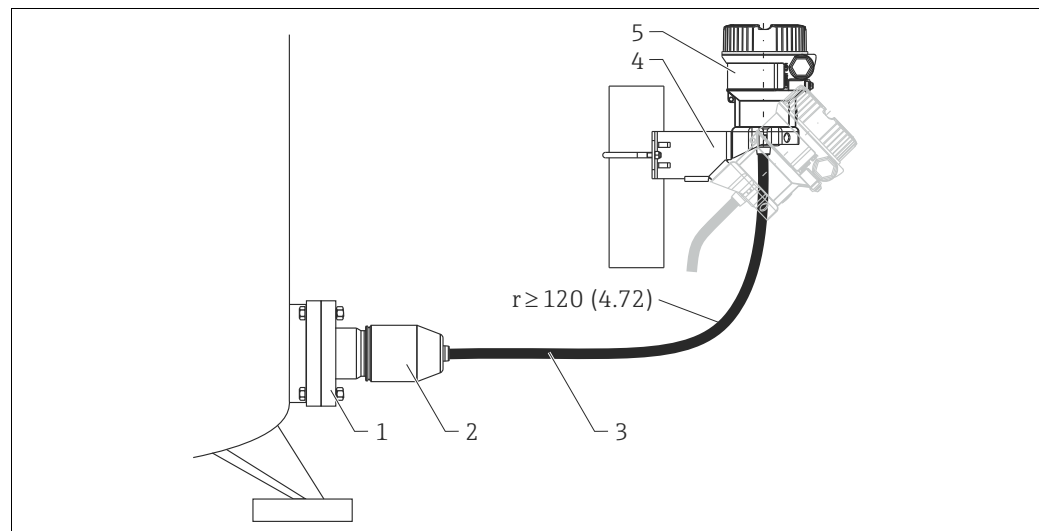

A0023567

Engineering unit mm (in)

In the case of the "separate housing" version, the sensor is delivered with the process connection and cable ready mounted. The housing and a mounting bracket are enclosed as separate units. The cable is provided with a socket at both ends. These sockets are simply connected to the housing and the sensor.

- 1 Process connection with sensor - see the following section for the degrees of protection
- 2 Process connection adapter (weight 0.93 kg (2.05 lbs))
- 3 Cable (weight 0.05 kg/Meter (0.11 lbs/meter)), both ends are fitted with a socket
- 4 Mounting bracket provided, suitable for pipe and wall mounting (for pipes from 1 1/4" up to 2" diameter)
- 5 Housing with electronic insert - degrees of protection →  40 ff

Degree of protection for the process connection and sensor with the use of

- FEP cable:
  - IP69<sup>1)</sup>
  - IP66 NEMA 4/6P
  - IP68 (1.83 mH<sub>2</sub>O for 24 h) NEMA 4/6P
- PE cable:
  - IP66 NEMA 4/6P
  - IP68 (1.83 mH<sub>2</sub>O for 24 h) NEMA 4/6P

Technical data of the PE and FEP cable:

- Minimum bending radius: 120 mm (4.72 in)
- Cable extraction force: max. 450 N (101 lbf)
- Resistance to UV light

Use in hazardous area:

- Intrinsically safe installations (Ex ia/IS)
- FM/CSA IS: for Div.1 installation only

1) Identification of IP protection category according to DIN EN 60529. The earlier designation "IP69K" according to DIN 40050 Part 9 is no longer valid (the standard was withdrawn on November 1, 2012). The tests required for both standards are identical.

**Oxygen applications**

Oxygen and other gases can react explosively to oils, grease and plastics. As a result, the following are some of the precautions that must be taken:

- All components of the system, such as measuring devices, must be cleaned in accordance with the BAM (DIN 19247) requirements.
- Depending on the materials used, a certain maximum temperature and maximum pressure must not be exceeded for oxygen applications.

The devices suitable for gaseous oxygen applications are listed in the following table with the specification  $p_{\max}$ .

Ordering code for devices <sup>1)</sup> cleaned for oxygen applications	$p_{\max}$ for oxygen applications	$T_{\max}$ for oxygen applications
PMC51 <sup>2)</sup> – devices with sensors, nominal value < 10 bar (150 psi)	Over pressure limit (OPL) of sensor <sup>3), 4)</sup>	60 °C (140°F)
PMC51 <sup>2)</sup> – devices with sensors, nominal value ≥ 10 bar (150 psi)	40 bar (600 psi)	60 °C (140°F)
PMP51 PMP55 <sup>2)</sup>	Depends on the lowest-rated element, with regard to pressure, of the selected components: over pressure limit (OPL) of sensor <sup>3)</sup> , process connection (1.5 x PN) or fill fluid (160 bar (2320 psi))	85 °C (185°F)

- 1) Only device, not accessory or enclosed accessory
- 2) Product Configurator, "Service" ordering feature, option "HB"
- 3) Product Configurator, "Sensor range" ordering feature
- 4) PMC51 with PVDF thread or PVDF flange  $p_{\max} = 15$  bar (225 psi)

**PWIS cleaning**

Special cleaning of the transmitter to remove paint-wetting substances, for use in paint shops, for instance.

Ordering information:

Product Configurator, "Service" ordering feature, option HC

The resistance of the materials used must be checked before the materials are used in the medium.

**Ultrapure gas applications  
(PMC51 and PMP51)**

Endress+Hauser also provides devices which have been cleaned of oil and grease for special applications, such as for ultrapure gas. No special restrictions regarding the process conditions apply to these devices.

Ordering information:

Product Configurator, "Service" ordering feature, option "HA"

**Applications with hydrogen**

A **ceramic** process isolating diaphragm or a **gold-plated** metal process isolating diaphragm offers universal protection against hydrogen diffusion, both in gas applications and in applications with aqueous solutions.

**Applications with hydrogen in aqueous solutions**

A **gold/rhodium-plated** metal process isolating diaphragm (AU/Rh) offers effective protection against hydrogen diffusion.

## Environment

### Ambient temperature range

Version	PMC51	PMP51	PMP55
Without LCD display	-40 °C to +85 °C (-40°F to +185°F)		
With LCD display <sup>1)</sup>	-20 °C to +70 °C (-4°F to +158°F)		
With M12 plug , elbowed	-25 °C to +85 °C (-13°F to +185°F)		
With separate housing	-20 °C to +60 °C (-4°F to +140°F) (installation without insulation)		—
Diaphragm seal systems <sup>2)</sup>	—	—	→ 107

- 1) Extended temperature application range (-40 °C to +85 °C (-40°F to +185°F)) with restrictions in optical properties such as display speed and contrast
- 2) Ambient temperature range and process temperature range are mutually dependent - see chapter "Thermal insulation" → 110

### NOTICE

#### High temperatures or vibrations can destroy the device!

For high-temperature applications, either a PMP55 with a temperature isolator or with a capillary can be used. If vibrations also occur in the application, Endress+Hauser recommends you use a PMP55 with a capillary. If a PMP55 with a temperature isolator or capillary is used, we recommend a suitable bracket for mounting (see "Wall and pipe mounting, transmitter (optional)" ordering feature → 37).

### Storage temperature range

Version	PMC51	PMP51	PMP55
Without LCD display	-40 °C to +90 °C (-40°F to +194°F)		
With LCD display	-40 °C to +85 °C (-40°F to +185°F)		
With M12 plug , elbowed	-25 °C to +85 °C (-13°F to +185°F)		
With separate housing	-40 °C to +60 °C (-40°F to +140°F)		—
Diaphragm seal systems <sup>1)</sup>	—	—	→ 107

- 1) Devices with PVC-sheathed capillary: -25...+90 °C (-13...+194 °F)

### Climate class

Class 4K4H (air temperature: -20 to 55 °C (-4 to +131°F), relative humidity: 4 to 100%) satisfied as per DIN EN 60721-3-4 (condensation possible).

### Degree of protection

- Depending on the used electrical connection → 23  
Ordering information:  
Product Configurator, "Electrical connection" ordering feature
- Separate housing (→ 38)



**Vibration resistance**

Device/Additional option	Test standard	Vibration resistance
Devices without mounting bracket	GL VI-7-2 <ul style="list-style-type: none"> <li>▪ Part 7: Guidelines for the Performance of Type Approvals</li> <li>▪ Chapter 2: Test Requirements for Electrical / Electronic Equipment and Systems</li> </ul>	guaranteed for 5 to 25 Hz: $\pm 1.6$ mm (0.06 in); 25 to 100 Hz: 4 g in all 3 planes
	IEC 61298-3 IEC 60068-2-6	guaranteed for 10 to 60 Hz: $\pm 0.35$ mm (0.01 in); 60 to 2000 Hz: 5 g in all 3 planes
Devices with mounting bracket	IEC 61298-3 IEC 60068-2-6	guaranteed for 10 to 60 Hz: $\pm 0.15$ mm (0.01 in); 60 to 500 Hz: 2 g in all 3 planes

**NOTICE**

**Strong vibrations can destroy the device!**

For high-vibration applications, either a PMC51/PMP51 with a separate housing or a PMP55 with a capillary can be used. We recommend a suitable bracket for mounting (see "Wall and pipe mounting, transmitter (optional)" ordering feature on →  37).

**Electromagnetic compatibility**

- Electromagnetic compatibility as per all the relevant requirements of the EN 61326 series and NAMUR Recommendation EMC (NE21).
- Maximum deviation: < 0.5 % of span

Further details can be found in the manufacturer declaration.

## Process

### Process temperature range PMC51

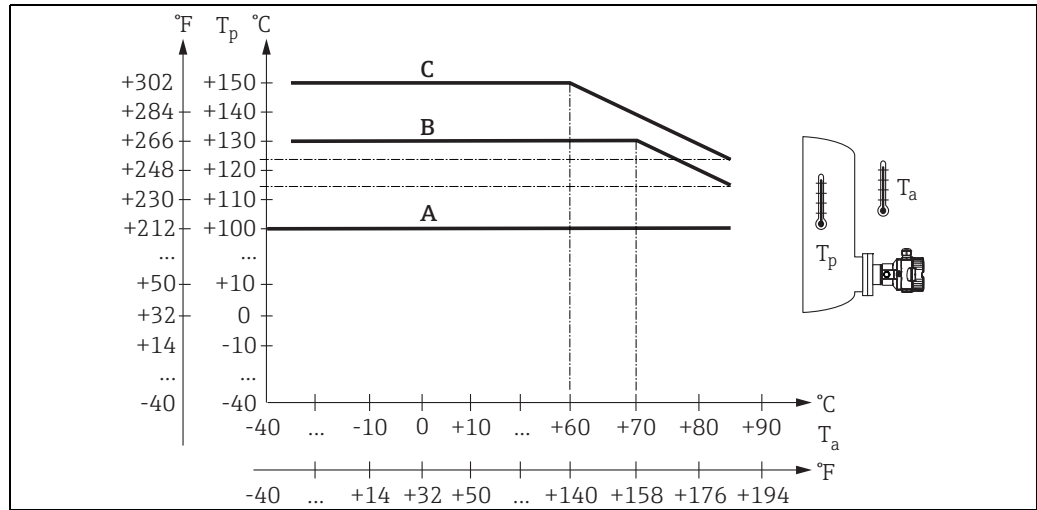

A, B and C, see next section.  $T_a$  = Ambient temperature.  $T_p$  = Process temperature.

### Process temperature limits

For oxygen applications, observe → 39, "Oxygen applications" ordering feature.

#### PMC51 (with ceramic process isolating diaphragm)

- A: -40 to +100 °C (-40 to +212°F) for threaded process connections or flange process connections
- B: -20 to +130 °C (-4 to +266°F) for hygienic process connections
- C: For a maximum of 60 minutes: +150 °C (+302°F) for hygienic process connections
- With applications involving saturated steam, a device with a metallic process isolating diaphragm must be used, or a siphon for temperature isolation should be provided during installation.
- Observe the process temperature range of the seal. See also the following table.

Seal	Notes	Process temperature range		Option <sup>1)</sup>
		Thread or flange	Hygienic process connections	
FKM Viton	-	-20 to +100 °C (-4 to +212°F)	-	A
FKM Viton	cleaned for O2 application	-5 to +60 °C (+23 to +140°F)	-	A <sup>2)</sup>
FKM Viton	FDA <sup>3)</sup> , 3A Class I, USP Class VI	-5 to +100 °C (+23 to +212°F)	-5 to +150 °C (+23 to +302°F)	B
FFKM Perlast G75LT	-	-20 to +100 °C (-4 to +212 °F)	-20 to +150 °C (-4 to +302 °F)	C
NBR	FDA <sup>3)</sup>	-10 to +100 °C (+14 to +212°F)	-	F
NBR, low temperature	-	-40 to +100 °C (-40 to +212°F)	-	H
HNBR	FDA <sup>3)</sup> , 3A Class I, KTW, AFNOR, BAM	-25 to +100 °C (-13 to +212°F)	-20 to +100 °C (-4 to +212°F)	G
EPDM 70	FDA <sup>3)</sup>	-40 to +100 °C (-40 to +212°F)	-	J
EPDM 291	FDA <sup>3)</sup> , 3A Class II, USP Class VI, DVGW, KTW, W270, WRAS, ACS, NSF61	-15 to +100 °C (+5 to +212°F)	-15 to +150 °C (+5 to +302°F)	K
FFKM Kalrez 6375	-	+5 to +100 °C (+41 to +212°F)	-	L
FFKM Kalrez 7075	-	+5 to +100 °C (+41 to +212°F)	-	M
FFKM Kalrez 6221	FDA <sup>3)</sup> , USP Class VI	-5 to +100 °C (+23 to +212°F)	-5 to +150 °C (+23 to +302°F)	N
Fluoroprene XP40	FDA <sup>3)</sup> , USP Class VI, 3A Class I	+5 to +100 °C (+41 to +212°F)	+5 to +150 °C (+41 to +302°F)	P
VMQ Silicone	FDA <sup>3)</sup>	-35 to +85 °C (-31 to +185°F)	-20 to +85 °C (-4 to +185°F)	S

1) Product Configurator, "Seal" ordering feature

2) With "HB" option, see Product Configurator, "Service" ordering feature

3) Suitable for foods FDA 21 CFR 177.2600

*Applications with jumps in temperature*

Extreme jumps in temperature can result in temporary measuring errors. Temperature compensation takes effect after several minutes. Internal temperature compensation is faster the smaller the jump in temperature and the longer the time interval involved.

For further information please contact your local Endress+Hauser Sales Center.

**PMP51 (with metallic process isolating diaphragm)**

Description	Temperature operating range
Process connections with internal process isolating diaphragm	-40 to +125 °C (-40 to +257°F)
Process connections with flush-mounted process isolating diaphragm, G 1/2 A, G 1 A, G 1 1/2" A, G 2 A, 1 NPT, 1 1/2" NPT, 2 NPT, M20x1.5, M44x1.25, EN/DIN, ANSI flanges	-40 to +100 °C (-40 to +212°F)
Process connections with flush-mounted process isolating diaphragm, G 1/2" A	-20 to +85 °C (-4 to +185°F)
Hygienic process connections	-40 to +130 °C (-40 to +266°F) For a maximum of 60 minutes: +150 °C (+302°F)

**PMP55 (with diaphragm seal)**

Depending on the diaphragm seal and filling oil from -70 °C (-94°F) up to +400 °C (+752°F). Observe the temperature application limits → [107](#).

*Devices with PTFE coated process isolating diaphragm*

The non-stick coating has excellent gliding properties and is used to protect the process isolating diaphragm against abrasive media.

**NOTICE**

**Destruction of the device due to incorrect use of PTFE foil!**

- ▶ The PTFE foil is designed to protect the unit against abrasion. It does not provide protection against corrosive media.

Permitted range of the 0.25 mm (0.01 in) PTFE foil on AISI 316L (1.4404/1.4435) process isolating diaphragm - see the following graphic:

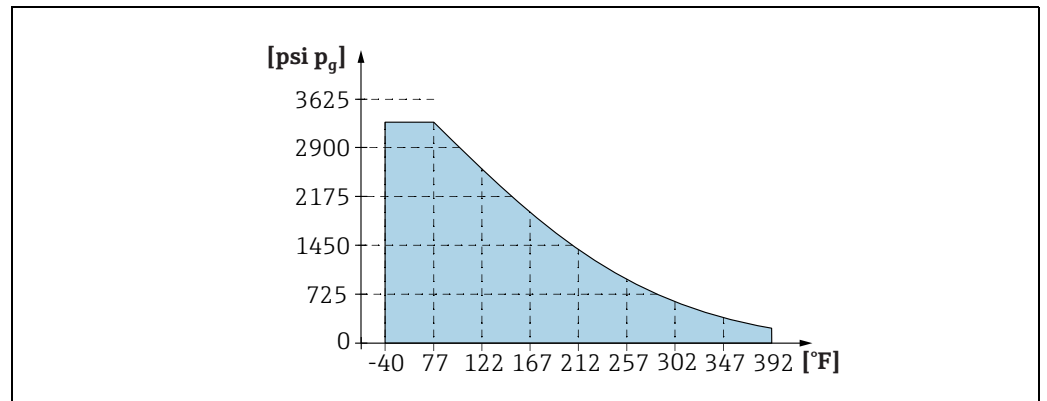

For vacuum applications:  $p_{abs} \leq 1$  bar (14.5 psi) to 0.05 bar (0.725 psi) to max. +150 °C (302 °F).

**Process temperature limits of flexible capillary armoring: PMP55**

- 316L: No restrictions
- PTFE: No restrictions
- PVC: See the following diagram

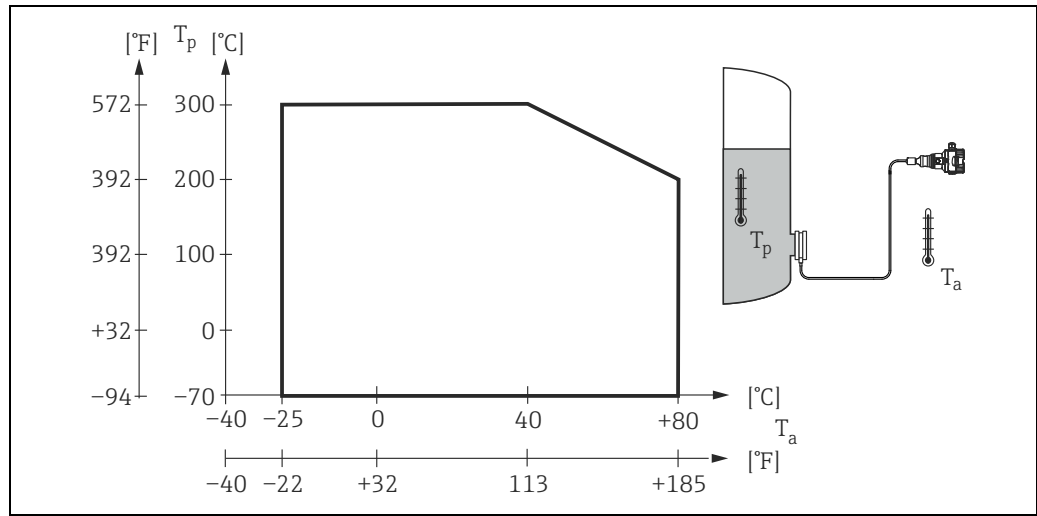

A0028227

**Pressure specifications**

**⚠ WARNING**

The maximum pressure for the measuring device depends on the lowest-rated element with regard to pressure → 13 ff, "Measuring range" ordering feature and → 45 ff "Mechanical construction" ordering feature

- ▶ Only operate the measuring device within the prescribed limits!
- ▶ The Pressure Equipment Directive (2014/68/EU) uses the abbreviation "PS". The abbreviation "PS" corresponds to the MWP (maximum working pressure) of the measuring device.
- ▶ The MWP (maximum working pressure) is specified on the nameplate. This value refers to a reference temperature of +20 °C (68°F) and may be applied to the device for an unlimited time. Observe temperature dependency of the MWP. The pressure values permitted at higher temperatures can be found in the standards EN 1092-1: 2001 Tab. 18 (With regard to their stability-temperature property, the materials 1.4435 and 1.4404 are grouped together under 13EO in EN 1092-1 Tab. 18. The chemical composition of the two materials can be identical.), ASME B 16.5a – 1998 Tab. 2-2.2 F316, ASME B 16.5a – 1998 Tab. 2.3.8 N10276, JIS B 2220.
- ▶ OPL (Over Pressure Limit = sensor overload limit):  
The test pressure corresponds to the over pressure limit of the sensor and may only be applied for a limited time period to ensure measurement within specification and in order to avoid permanent damage. In the case of sensor range and process connections where the over pressure limit (OPL) of the process connection is smaller than the nominal value of the sensor, the device is set at the factory, at the very maximum, to the OPL value of the process connection. If you want to use the entire sensor range, select a process connection with a higher OPL value.
- ▶ Oxygen applications:  
The values for  $p_{\max}$  and  $T_{\max}$  for oxygen applications" as per → 39, "Oxygen applications" may not be exceeded.
- ▶ Devices with ceramic process isolating diaphragm: Avoid steam hammering!  
Steam hammering can cause zero point drift.  
Recommendation: Residue (such as condensation or drops of water) can remain at the process isolating diaphragm after CIP cleaning and lead to local steam hammering if immediately steam is introduced. In practice, drying the process isolating diaphragm (e.g. by blowing off excess moisture) has proven to be a successful way of avoiding steam hammering.

## Mechanical construction

### Device height

The device height is calculated from

- the height of the housing and
- the height of the individual process connection.

The individual heights of the components are listed in the following sections. To calculate the device height simply add up the individual heights of the components. Where applicable also take into consideration the installation distance (space that is used to install the device).

You can use the following table for this purpose:

Section	Page	Height
Housing height	→ 45 ff	
Process connections	→ 47 ff	
Installation distance		
Device height		

### F31 housing, aluminum

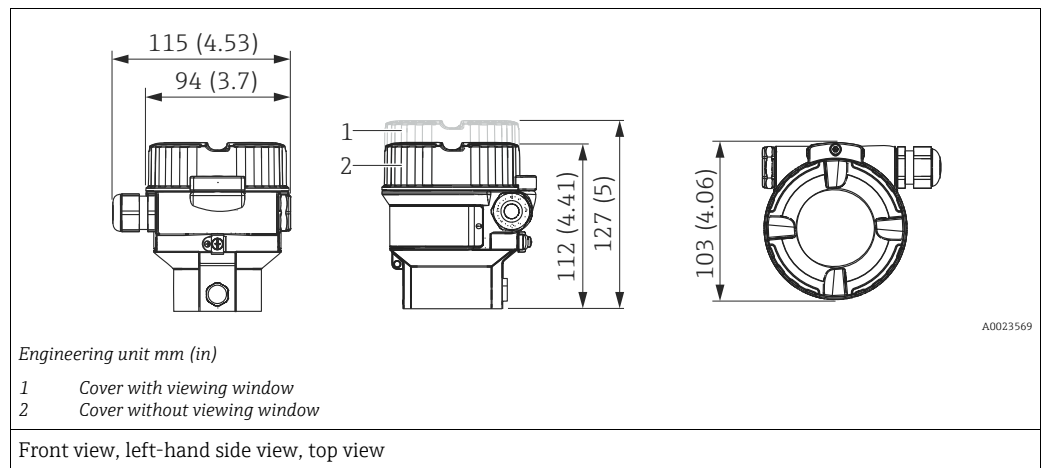

Material	Weight kg (lbs)		Option <sup>1)</sup>
	With display	Without display	
Aluminum <sup>2)</sup>	1.1 (2.43)	1.0 (2.21)	I
Aluminum with glass viewing window <sup>2)</sup>			J

1) Product Configurator, "Housing" ordering feature

2) Degree of protection dependent on cable entry used → 23

**F15 housing, stainless steel (hygienic)**

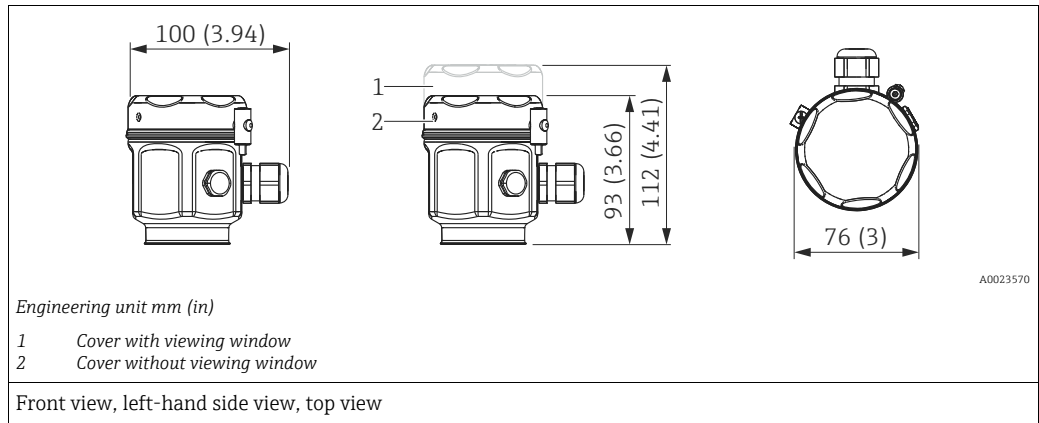

Material	Weight kg (lbs)		Option <sup>1)</sup>
	With display	Without display	
Stainless steel <sup>2)</sup>	1.1 (2.43)	1.0 (2.21)	Q
Stainless steel with glass viewing window <sup>2)</sup>			R
Stainless steel with plastic viewing window <sup>2)</sup>			S

- 1) Product Configurator, "Housing" ordering feature
- 2) Degree of protection dependent on cable entry used → 23

**PMC51: process connections ISO 228 G threaded connection with internal process isolating diaphragm**

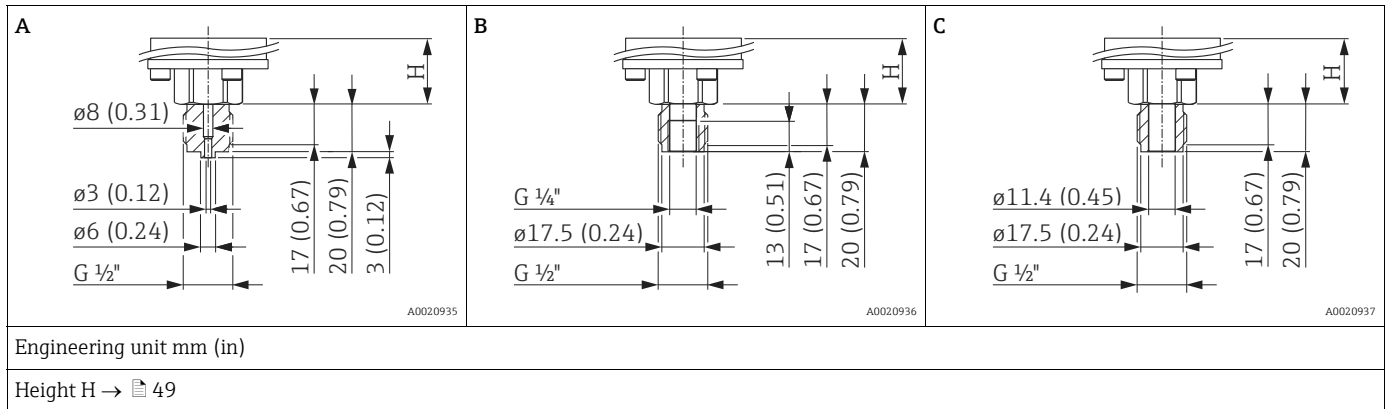

Item	Designation	Material	Approval <sup>1)</sup>	Weight kg (lbs)	Option <sup>2)</sup>
A	Thread ISO 228 G 1/2" A EN 837	AISI 316L	CRN	0.63 (1.39)	G CJ
		Alloy C276 (2.4819)	CRN		G CC
		<b>PVDF</b> <ul style="list-style-type: none"> <li>▪ Mount only with enclosed mounting bracket</li> <li>▪ MWP 10 bar (150 psi), OPL max. 15 bar (225 psi)</li> <li>▪ Process temperature range: -10 to +60 °C (-14 to +140°F)</li> </ul>	-		G CF
B	Thread ISO 228 G 1/2" A G 1/4" (female)	AISI 316L	CRN		GL J
		Alloy C276 (2.4819)	CRN		GL C
C	Thread ISO 228 G 1/2" A, Bore 11.4 mm (0.45 in)	AISI 316L	CRN	GM J	
		Alloy C276 (2.4819)	CRN	GM C	

- 1) CSA approval: Product Configurator, "Approval" ordering feature
- 2) Product Configurator, "Process connection" ordering feature

PMC51: process connections with internal process isolating diaphragm

ANSI threaded connection

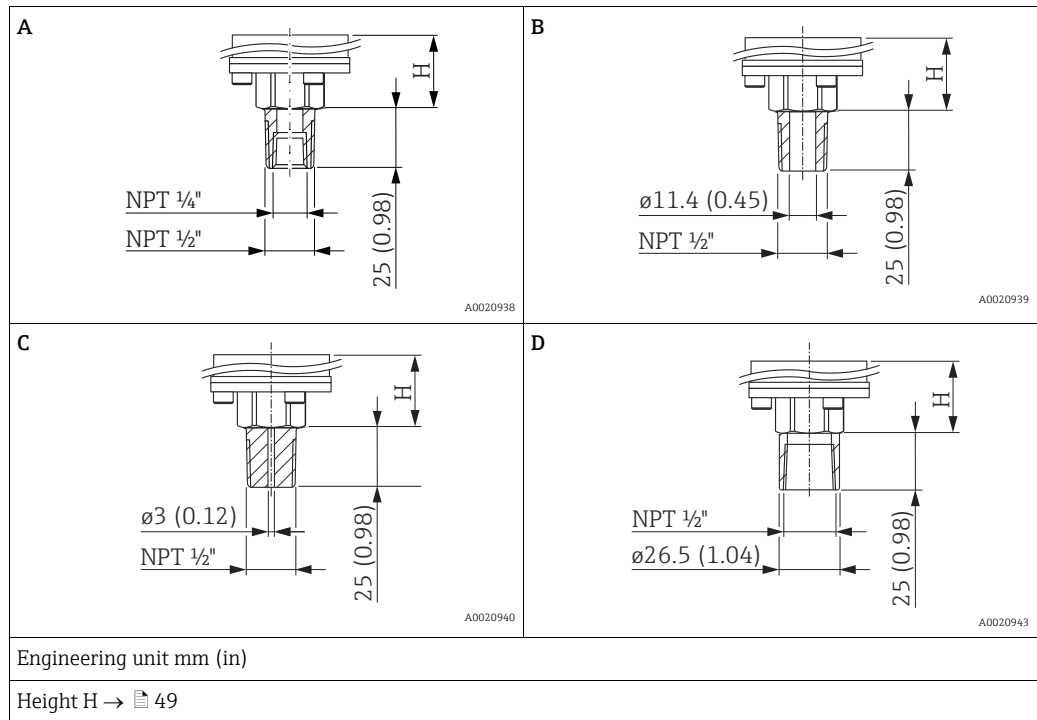

Item	Designation	Material	Weight kg (lbs)	Approval <sup>1)</sup>	Option <sup>2)</sup>
A	ANSI ½" MNPT, ¼" FNPT	AISI 316L	0.63 (1.39)	CRN	RLJ
		Alloy C276 (2.4819)		CRN	RLC
B	ANSI ½" MNPT, Bore 11.4 mm (0.45 in)	AISI 316L		CRN	RKJ
		Alloy C276 (2.4819)		CRN	RKC
C	ANSI ½" MNPT, Bore 3 mm (0.12 in)	<b>PVDF</b> <ul style="list-style-type: none"> <li>■ Mount only with enclosed mounting bracket</li> <li>■ MWP 10 bar (150 psi), OPL max. 15 bar (225 psi)</li> <li>■ Process temperature range: +10 to +60 °C (+14 to +140°F)</li> </ul>		-	RJF
D	ANSI ½" FNPT Bore 11.4 mm (0.45 in)	AISI 316L		CRN	R1J
		Alloy C276 (2.4819)	CRN	R1C	

1) CSA approval: Product Configurator, "Approval" ordering feature

2) Product Configurator, "Process connection" ordering feature



**PMC51: process connections with internal process isolating diaphragm**

**JIS threaded connection**

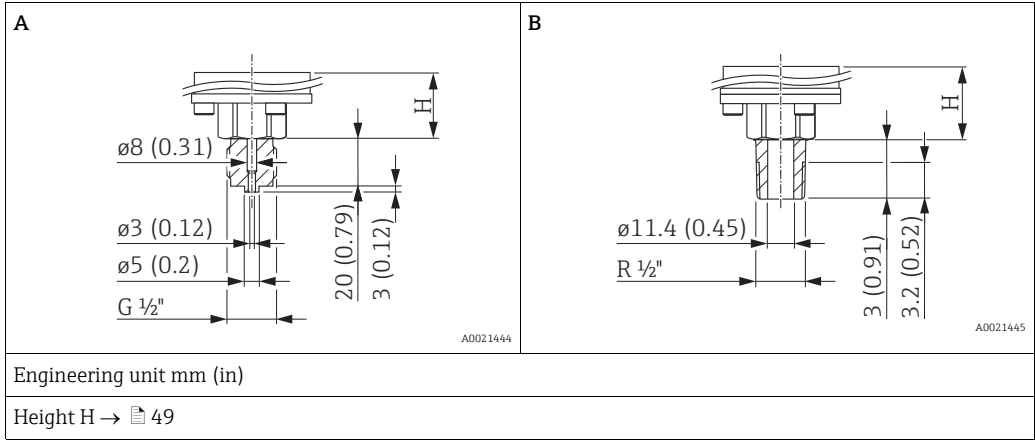

Item	Designation	Material	Weight kg (lbs)	Option <sup>1)</sup>
A	JIS B0202 G 1/2" (male)	AISI 316L	0.63 (1.39)	GNJ
B	JIS B0203 R 1/2" (male)			GOJ

1) Product Configurator, "Process connection" ordering feature

**DIN 13 threaded connection**

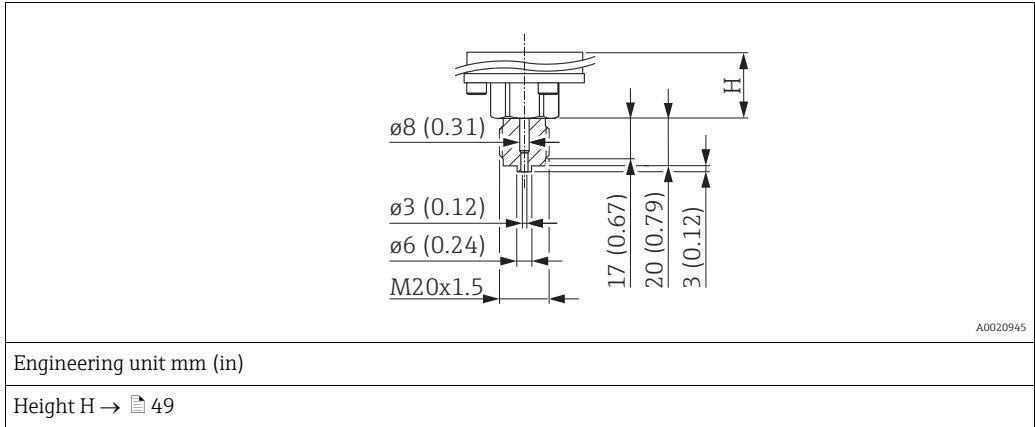

Designation	Material	Weight kg (lbs)	Option <sup>1)</sup>
DIN 13 EN837 M20 x 1,5, Bore 3 mm (0.12 in)	AISI 316L	0.63 (1.39)	G5J
	Alloy C (2.4819)	0.63 (1.39)	G6J

1) Product Configurator, "Process connection" ordering feature

**PMC51: process connections with internal process isolating diaphragm - height H**

F31 housing	F15 housing
27 mm (1.06 in)	34 mm (1.34 in)

PMC51: process connections with flush-mounted process isolating diaphragm

DIN 13 threaded connection

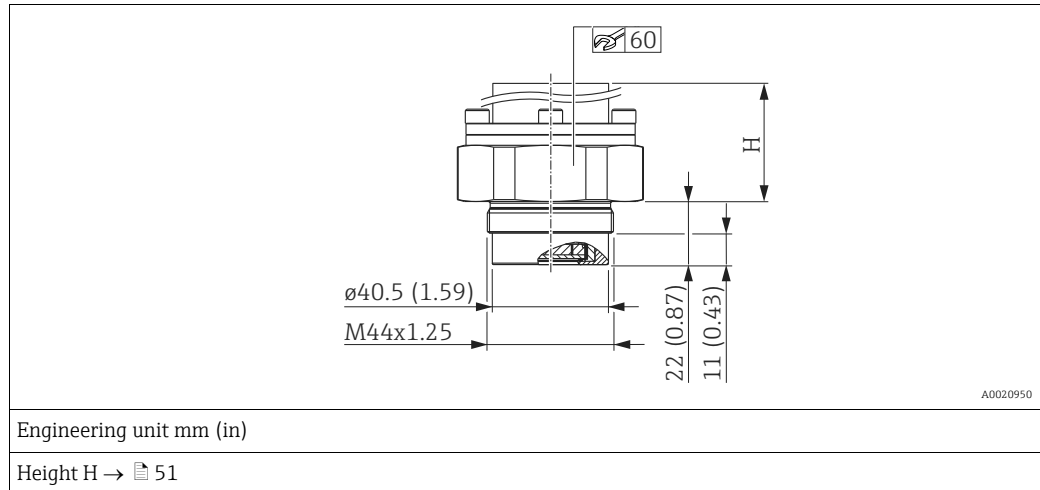

Designation	Material	Weight kg (lbs)	Option <sup>1)</sup>
DIN 13 M44 x 1.25	AISI 316L	0.63 (1.39)	G4J

1) Product Configurator, "Process connection" ordering feature

ISO 228 G threaded connection

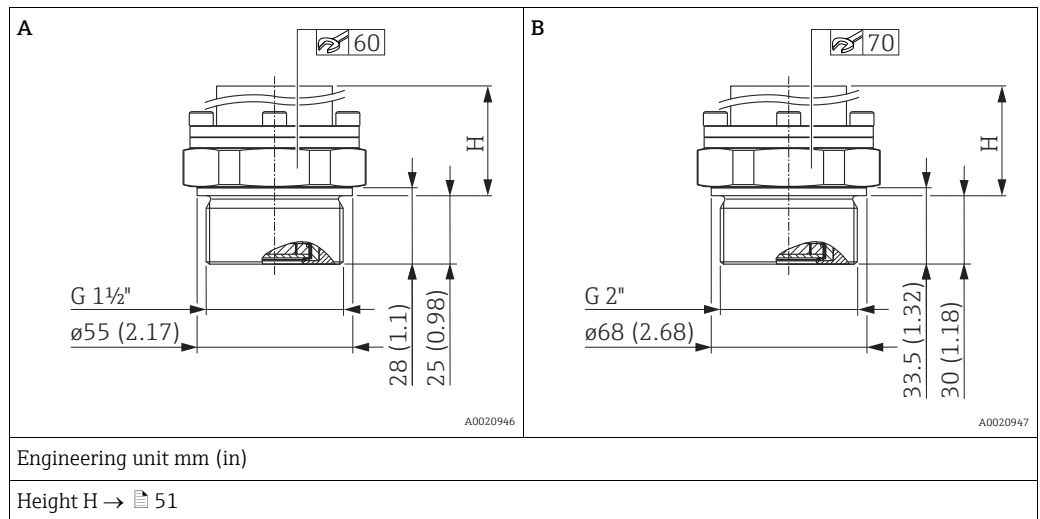

Item	Designation	Material	Weight kg (lbs)	Option <sup>1)</sup>
A	Thread ISO 228 G 1 1/2" A	AISI 316L	0.63 (1.39)	GVJ
B	Thread ISO 228 G 2" A	AISI 316L		GWJ

1) Product Configurator, "Process connection" ordering feature

**PMC51: process connections with flush-mounted process isolating diaphragm**

**ANSI threaded connection**

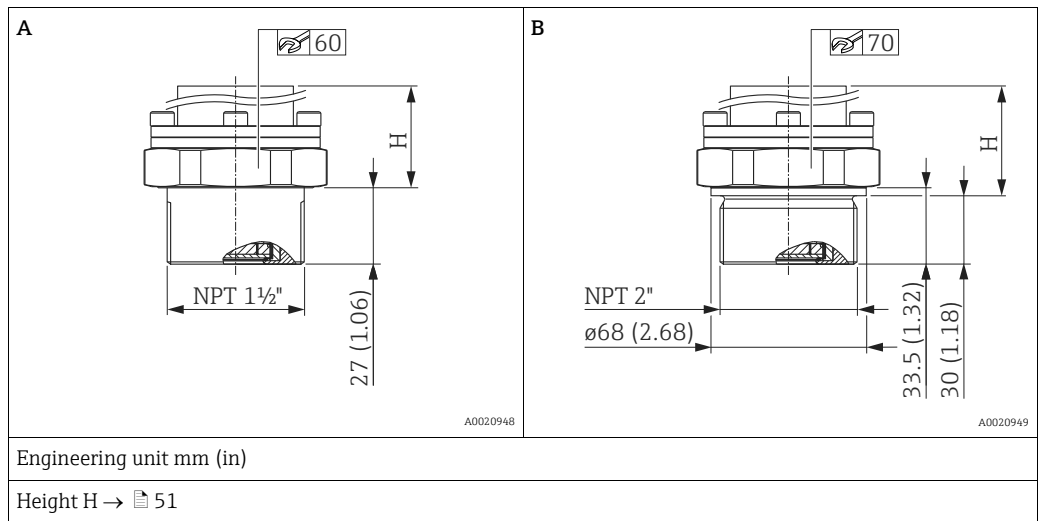

Item	Designation	Material	Weight kg (lbs)	Approval <sup>1)</sup>	Option <sup>2)</sup>
A	Thread ANSI 1 1/2" MNPT	AISI 316L	0.63 (1.39)	CRN	U7J
B	Thread ANSI 2" MNPT	AISI 316L		CRN	U8J

- 1) CSA approval: Product Configurator, "Approval" ordering feature
- 2) Product Configurator, "Process connection" ordering feature

**PMC51: process connections with flush-mounted process isolating diaphragm - height H**

Process connection	F31 housing	F15 housing
DIN 13 M44 x 1,25	53 mm (2.09 in)	60 mm (2.36 in)
Thread ISO 228 G 1 1/2" A	50 mm (1.97 in)	57 mm (2.24 in)
Thread ISO 228 G 2" A	45 mm (1.77 in)	52 mm (2.05 in)
Thread ANSI 1 1/2" MNPT	48 mm (1.89 in)	55 mm (2.17 in)
Thread ANSI 2" MNPT	45 mm (1.77 in)	52 mm (2.05 in)

PMC51: process connections with flush-mounted process isolating diaphragm

EN/DIN flanges, connection dimensions as per EN 1092-1/DIN 2527

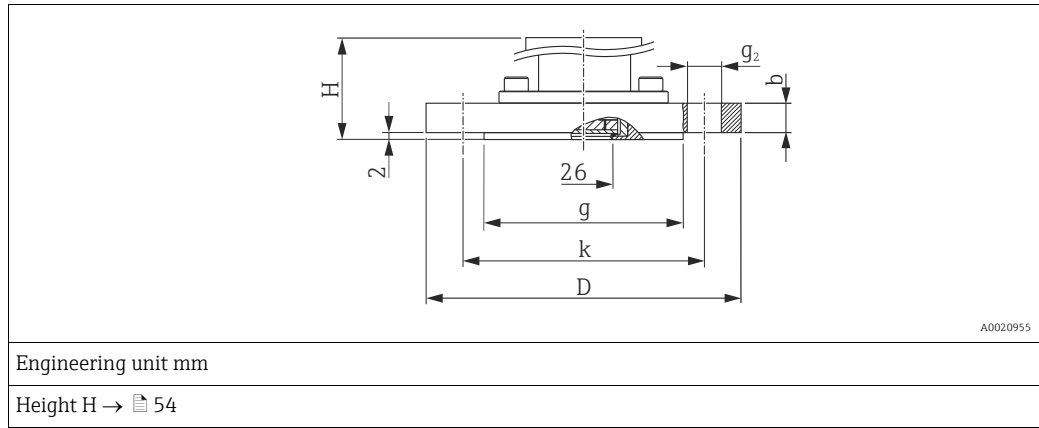

Flange							Boltholes			Weight	Option <sup>1)</sup>
Material	Nominal diameter	Nominal pressure	Shape <sup>2)</sup>	D	Thickness b	Raised face g	Quantity	g <sub>2</sub>	Hole circle k		
				[mm]	[mm]	[mm]		[mm]	[mm]	[kg]	
AISI 316L	DN 25	PN 10-40	B1 (D)	115	18	68	4	14	85	1.4 (3.09)	CNJ
AISI 316L	DN 32	PN 10-40	B1 (D)	140	18	78	4	18	100	2.0 (4.41)	CPJ
AISI 316L	DN 40	PN 10-40	B1 (D)	150	18	88	4	18	110	2.4 (5.29)	CQJ
ECTFE <sup>3)</sup>	DN 40	PN 10-40	B2 (E)	150	21	88	4	18	110	2.6 (5.73)	CQP
AISI 316L	DN 50	PN 10-40	B1 (D)	165	20	102	4	18	125	3.2 (7.06)	CXJ
PVDF	DN 50	PN 10-16	B2 (E)	165	21.4	102	4	18	125	0.6 (1.32)	CFF
ECTFE <sup>3)</sup>	DN 50	PN 25-40	B2 (E)	165	20	102	4	18	125	3.2 (7.06)	CRP
AISI 316L	DN 80	PN 10-40	B1 (D)	200	24	138	8	18	160	5.4 (11.91)	CZJ
ECTFE <sup>3)</sup>	DN 80	PN 25-40	B2 (E)	200	24	138	8	18	160	5.5 (12.13)	CSP

1) Product Configurator, "Process connection" ordering feature

2) Designation as per DIN 2527 in brackets

3) ECTFE coating on AISI 316L (1.4404). When operating in hazardous areas, avoid electrostatic charging of the plastic surfaces.

**PMC51: process connections with flush-mounted process isolating diaphragm**

**ASME flanges, connection dimensions as per ASME B 16.5, raised face RF**

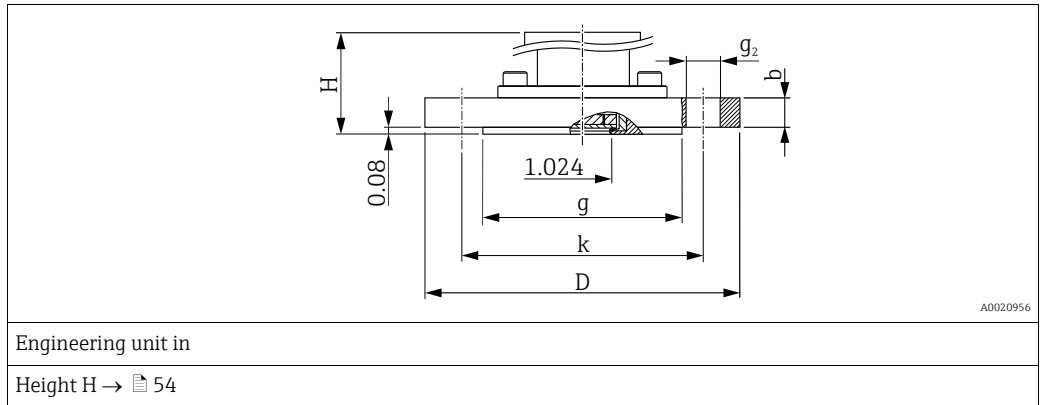

Flange						Boltholes			Weight	Approval <sup>1)</sup>	Option <sup>2)</sup>
Material	Nominal diameter	Class	D	Thickness b	Raised face g	Quantity	g <sub>2</sub>	Hole circle k			
	[in]	[lb./sq.in]	[in]	[in]	[in]		[in]	[in]	[kg (lbs)]		
AISI 316/316L <sup>4)</sup>	1	150	4.25	1.18	2	4	0.62	3.12	0.9 (1.98)	-	ACJ <sup>3)</sup>
AISI 316/316L <sup>4)</sup>	1	300	4.88	1.18	2	4	0.75	3.5	1.4 (3.09)	-	ANJ <sup>3)</sup>
AISI 316/316L <sup>4)</sup>	1 ½	150	5	0.69	2.88	4	0.62	3.88	1.0 (2.21)	CRN	AEJ
AISI 316/316L <sup>4)</sup>	1 ½	300	6.12	0.81	2.88	4	0.88	4.5	2.6 (5.73)	CRN	AQJ
AISI 316/316L <sup>4)</sup>	2	150	6	0.75	3.62	4	0.75	4.75	2.4 (5.29)	CRN	AFJ
ECTFE <sup>5)</sup>	2	150	6	0.75	3.62	4	0.75	4.75	2.4 (5.29)	-	AFN
PVDF	2	150	6	0.75	3.62	4	0.75	4.75	0.5 (1.1)	-	AFF
AISI 316/316L <sup>4)</sup>	2	300	6.5	0.88	3.62	8	0.75	5	3.2 (7.06)	CRN	ARJ
AISI 316/316L <sup>4)</sup>	3	150	7.5	0.94	5	4	0.75	6	4.9 (10.8)	CRN	AGJ
ECTFE <sup>5)</sup>	3	150	7.5	0.94	5	4	0.75	6	4.9 (10.8)	-	AGN
PVDF	3	150	7.5	0.94	5	4	0.75	6	0.9 (1.98)	-	AGF
AISI 316/316L <sup>4)</sup>	3	300	8.25	1.12	5	8	0.88	6.62	6.8 (14.99)	CRN	ASJ
AISI 316/316L <sup>4)</sup>	4	150	9	0.94	6.19	8	0.75	7.5	7.1 (15.66)	CRN	AHJ
ECTFE <sup>5)</sup>	4	150	9	0.94	6.19	8	0.75	7.5	7.1 (15.66)	-	AHN
AISI 316/316L <sup>4)</sup>	4	300	10	1.25	6.19	8	0.88	7.88	11.6 (25.58)	CRN	ATJ

- 1) CSA approval: Product Configurator, “Approval” ordering feature
- 2) Product Configurator, “Process connection” ordering feature
- 3) Screws must be 15 mm (0.59 in) longer than the standard flange screws.
- 4) Combination of AISI 316 for required pressure resistance and AISI 316L for required chemical resistance (dual rated)
- 5) ECTFE coating on AISI 316/316L. When operating in hazardous areas, avoid electrostatic charging of the plastic surfaces.

PMC51: process connections with flush-mounted process isolating diaphragm

JIS flanges, connection dimensions as per JIS B 2220 BL, raised face RF

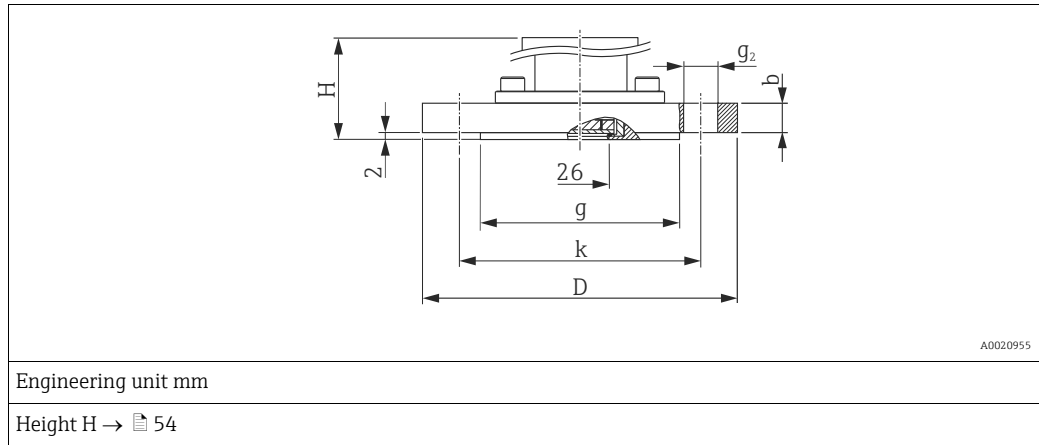

Flange						Boltholes			Weight	Option <sup>1)</sup>
Material	Nominal diameter	Nominal pressure	D	Thickness b	Raised face g	Quantity	g <sub>2</sub>	Hole circle k		
			[mm]	[mm]	[mm]		[mm]	[mm]	[kg (lbs)]	
AISI 316L (1.4435)	50 A	10 K	155	16	96	4	19	120	2.0 (4.41)	KFJ
	80 A	10 K	185	18	127	8	19	150	3.3 (7.28)	KGJ
	100 A	10 K	210	18	151	8	19	175	4.4 (9.7)	KHJ

1) Product Configurator, "Process connection" ordering feature

PMC51: process connections with flush-mounted process isolating diaphragm - height H

F31 housing	F15 housing
94 mm (3.7 in)	98 mm (3.86 in)

**PMC51: hygienic process connections with flush-mounted process isolating diaphragm**

In order to guarantee a hygiene approval, a seal with appropriate approval must be selected for the hygienic process connection:

- For 3A approval, you require a seal made of EPDM or HNBR (→ 42).
- For EHEDG approval, you require a seal made of VMQ silicone, FFKM Kalrez (→ 42).

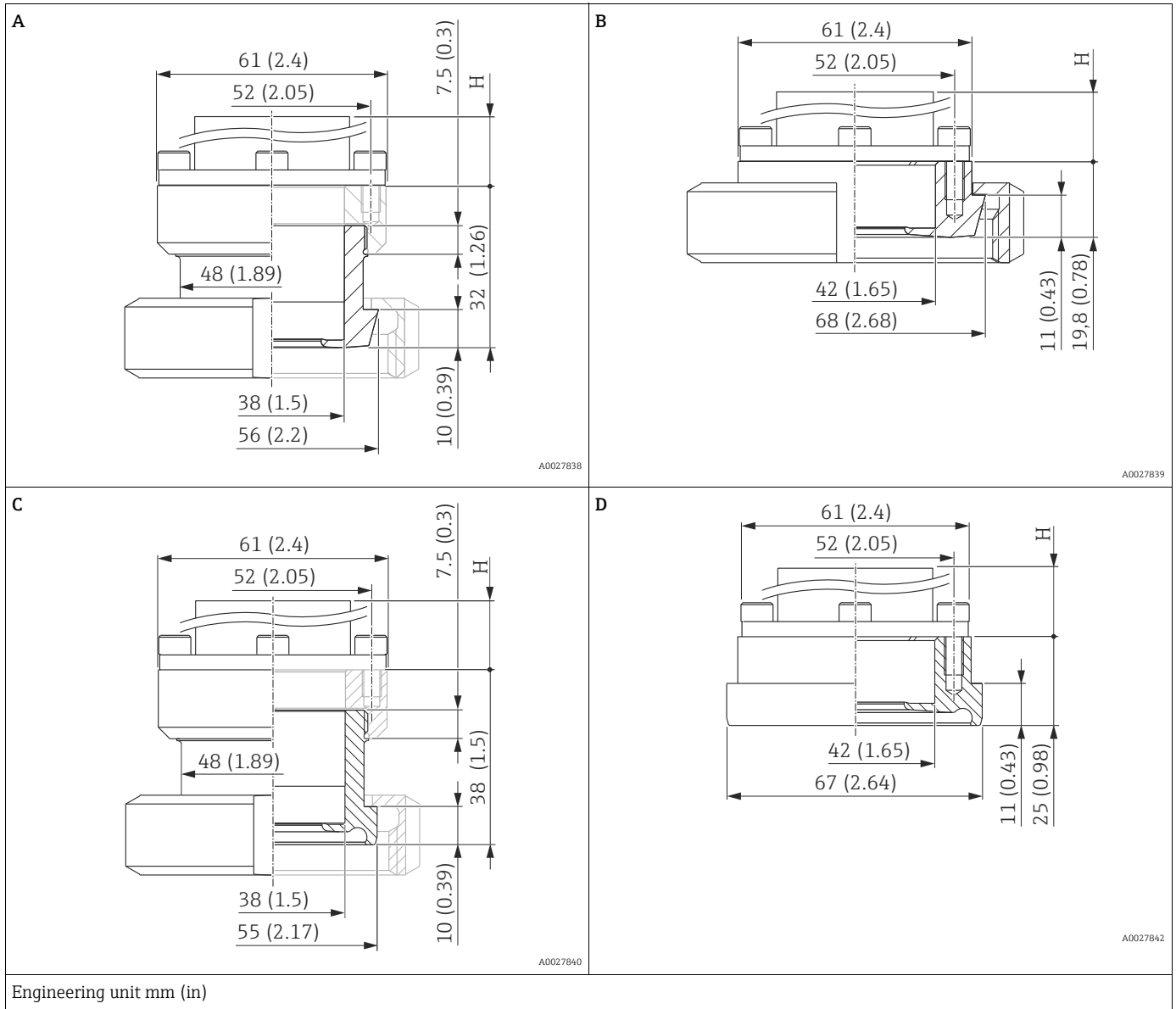

Item	Designation	Nominal pressure	Material <sup>1)</sup>	Weight kg (lbs)	Approval <sup>2)</sup>	Option <sup>3)</sup>
A	DIN 11851 DN40	PN 25	AISI 316L (1.4435)	0.7 (1.54)	EHEDG, 3A with seal FDA, ASME-BPE, CRN	MZJ <sup>4)</sup>
B	DIN 11851 DN50	PN 25		0.9 (1.98)	EHEDG, 3A with seal FDA, ASME-BPE, CRN	MRJ <sup>4)</sup>
C	DIN 11864 DN40, pipe DIN 11866-A	PN 16		0.66 (1.46)	EHEDG, 3A with seal FDA, ASME-BPE	NCJ <sup>4)</sup>
D	DIN 11864 DN50, pipe DIN 11866-A	PN 16		0.29 (0.64)	EHEDG, 3A with seal FDA, ASME-BPE	NDJ <sup>4)</sup>

- 1) Delta ferrite content <1 %. The roughness of the surface in contact with the medium is R<sub>a</sub> 0.76 µm (30 µin).
- 2) CSA approval: Product Configurator, "Approval" ordering feature
- 3) Product Configurator, "Process connection" ordering feature
- 4) Endress+Hauser supplies these slotted nuts in stainless steel AISI 304 (DIN/EN material number 1.4301) or in AISI 304L (DIN/EN material number 1.4307).

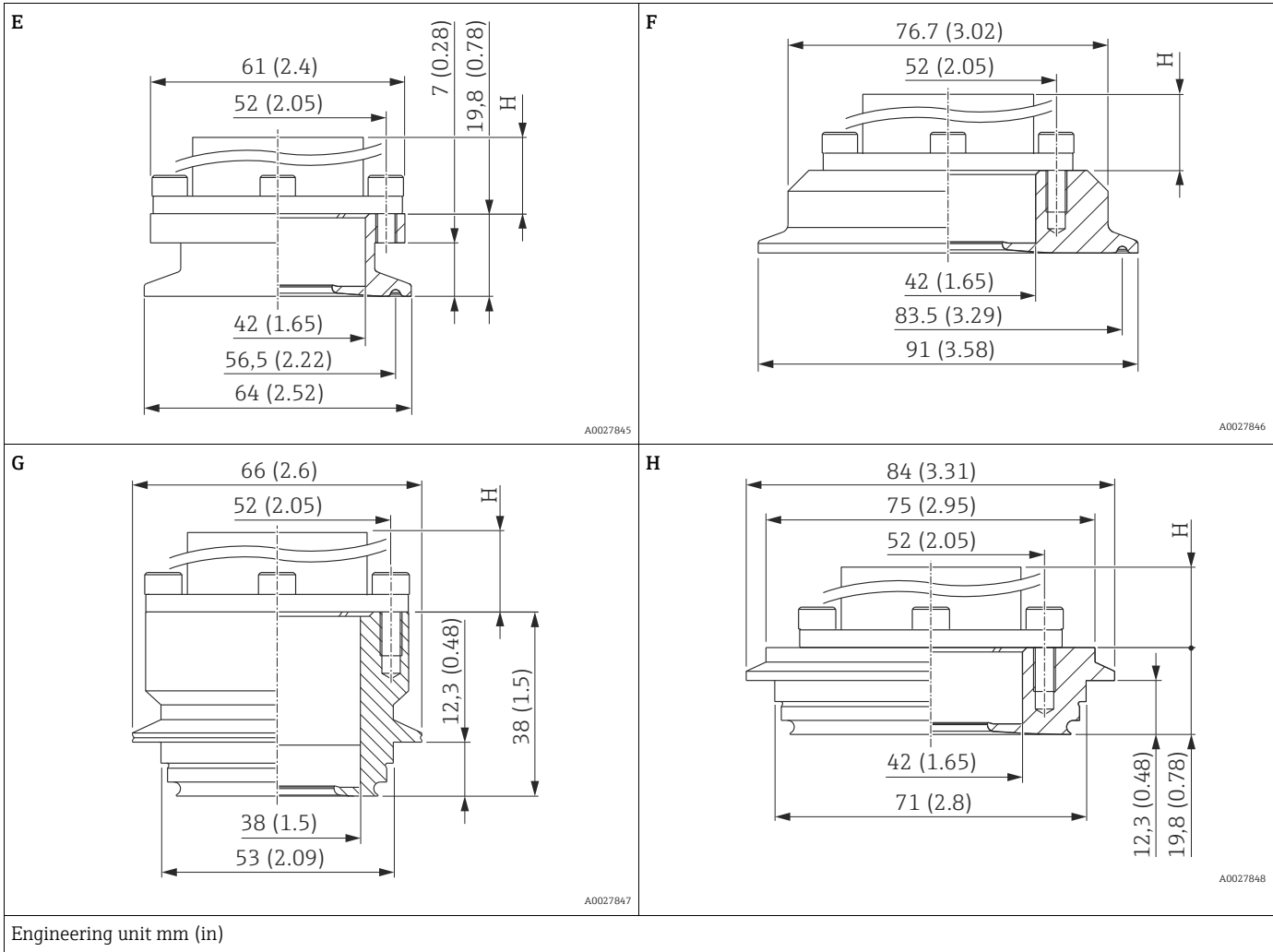

Item	Designation	Nominal pressure	Material <sup>1)</sup>	Weight kg (lbs)	Approval <sup>2)</sup>	Option <sup>3)</sup>
E	Tri-Clamp ISO 2852, DN40-DN51 (2")	PN 40	AISI 316L (1.4435)	0.65 (1.44)	EHEDG, 3A with seal FDA, CRN, ASME-BPE	TDJ <sup>4)</sup>
F	Tri-Clamp ISO 2852, DN76.1 (3")	PN 40		0.9 (1.98)	EHEDG, 3A with seal FDA, CRN, ASME-BPE	TFJ <sup>4)</sup>
G	Varivent F pipe, DN25-32	PN 40		0.46 (1)	EHEDG, 3A with seal FDA, ASME-BPE	TQJ
H	Varivent N pipe, DN40-162	PN 40		1 (2.21)	EHEDG, 3A with seal FDA, ASME-BPE	TRJ

1) Delta ferrite content <1 %. The roughness of the surface in contact with the medium is R<sub>a</sub> 0.76 μm (30 μin).

2) CSA approval: Product Configurator, "Approval" ordering feature

3) Product Configurator, "Process connection" ordering feature

4) Endress+Hauser supplies these slotted nuts in stainless steel AISI 304 (DIN/EN material number 1.4301) or in AISI 304L (DIN/EN material number 1.4307).



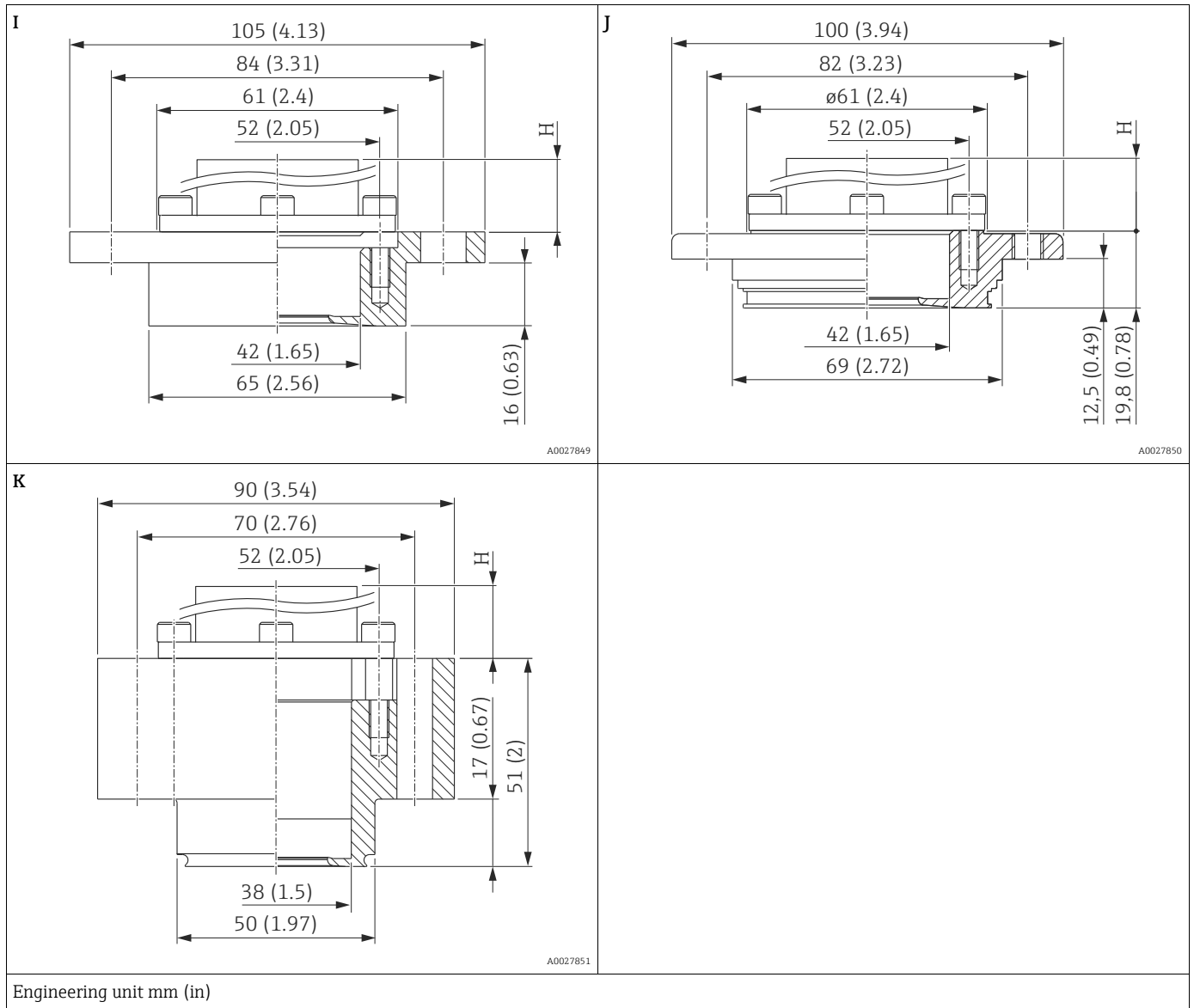

Item	Designation	Nominal pressure	Material <sup>1)</sup>	Weight kg (lbs)	Approval <sup>2)</sup>	Option <sup>3)</sup>
I	DRD, DN50 (65 mm)	PN 25	AISI 316L (1.4435)	0.9 (1.98)	FDA	TIJ <sup>4)</sup>
J	APV Inline, DN50	PN 40		0.52 (1.15)	3A with seal FDA, CRN, ASME-BPE	TMJ
K	NEUMO BioControl, DN50	PN 16		1.34 (2.6)	3A with seal FDA, ASME-BPE	S4J <sup>5)</sup>

- 1) Delta ferrite content <1 %. The roughness of the surface in contact with the medium is  $R_a$  0.76  $\mu$ m (30  $\mu$ in).
- 2) CSA approval: Product Configurator, order code for "Approval".
- 3) Product Configurator, "Process connection" ordering feature
- 4) Endress+Hauser supplies these slotted nuts in stainless steel AISI 304 (DIN/EN material number 1.4301) or in AISI 304L (DIN/EN material number 1.4307).
- 5) 4 screws DIN912 M8 x 45 are enclosed (material A4-80)

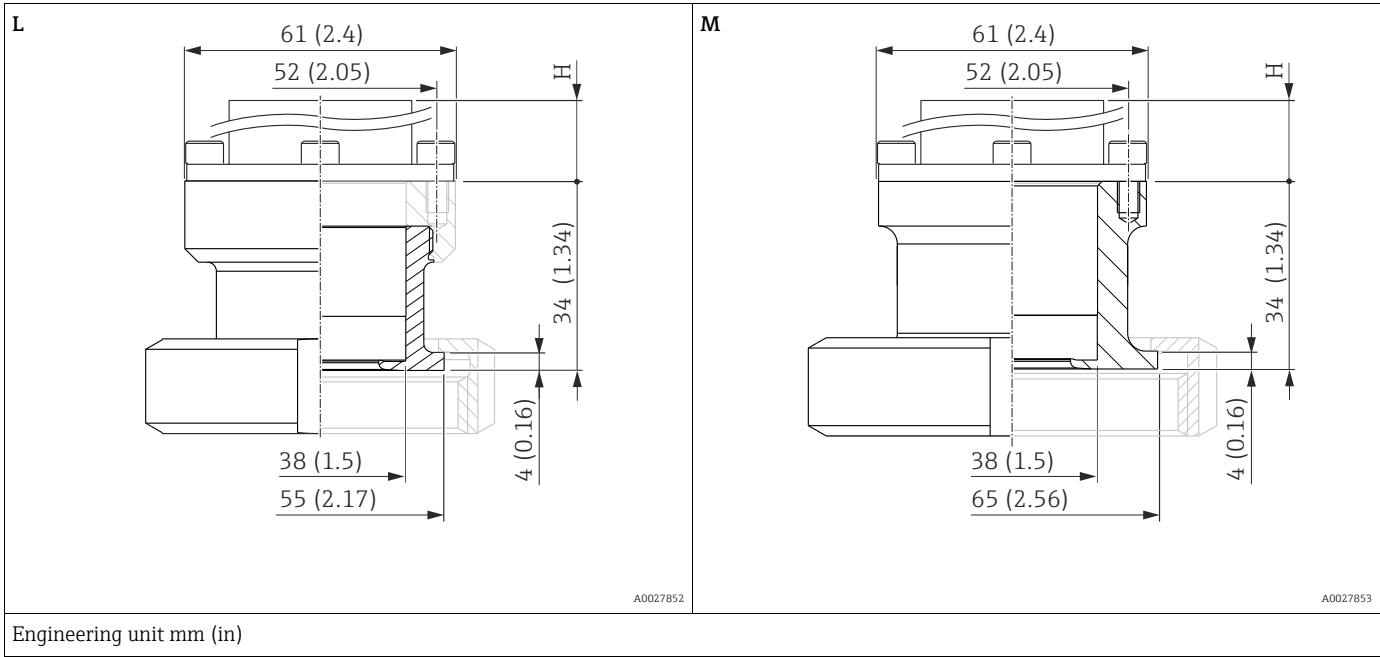

Item	Designation	Nominal pressure	Material <sup>1)</sup>	Weight kg (lbs)	Approval <sup>2)</sup>	Option <sup>3)</sup>
L	SMS 1 ½"	PN 25	AISI 316L (1.4435)	0,65 (1.43)	EHEDG, 3A, ASME-BPE	TXJ <sup>4)</sup>
M	SMS 2"	PN 25				T7J <sup>4)</sup>

- 1) Delta ferrite content <1 %. The roughness of the surface in contact with the medium is R<sub>a</sub> 0.76 µm (30 µin).
- 2) CSA approval: Product Configurator, order code for "Approval".
- 3) Product Configurator, "Process connection" ordering feature
- 4) Endress+Hauser supplies the slotted nuts in stainless steel AISI 304 (DIN/EN material number 1.4301) or in AISI 304L (DIN/EN material number 1.4307).

**Height H**

Item	Process connection	F31 housing	F15 housing
A	DIN 11851 DN40	48 mm (1.89 in)	54 mm (2.13 in)
B	DIN 11851 DN50	70 mm (2.76 in)	77 mm (3.03 in)
C	DIN 11864 DN40, pipe DIN 11866-A	48 mm (1.89 in)	54 mm (2.13 in)
D	DIN 11864 DN50, pipe DIN 11866-A	70 mm (2.76 in)	77 mm (3.03 in)
E	Tri-Clamp ISO 2852, DN40-DN51 (2")	70 mm (2.76 in)	77 mm (3.03 in)
F	Tri-Clamp ISO 2852, DN76.1 (3")	70 mm (2.76 in)	77 mm (3.03 in)
G	Varivent F pipe, DN25-32	48 mm (1.89 in)	54 mm (2.13 in)
H	Varivent N pipe, DN40-162	70 mm (2.76 in)	77 mm (3.03 in)
I	DRD, DN50 (65 mm)	70 mm (2.76 in)	77 mm (3.03 in)
J	APV Inline, DN50	70 mm (2.76 in)	77 mm (3.03 in)
K	NEUMO BioControl, DN50	48 mm (1.89 in)	54 mm (2.13 in)
L	SMS 1 ½"	48 mm (1.89 in)	54 mm (2.13 in)
M	SMS 2"	48 mm (1.89 in)	54 mm (2.13 in)

**Universal adapter**

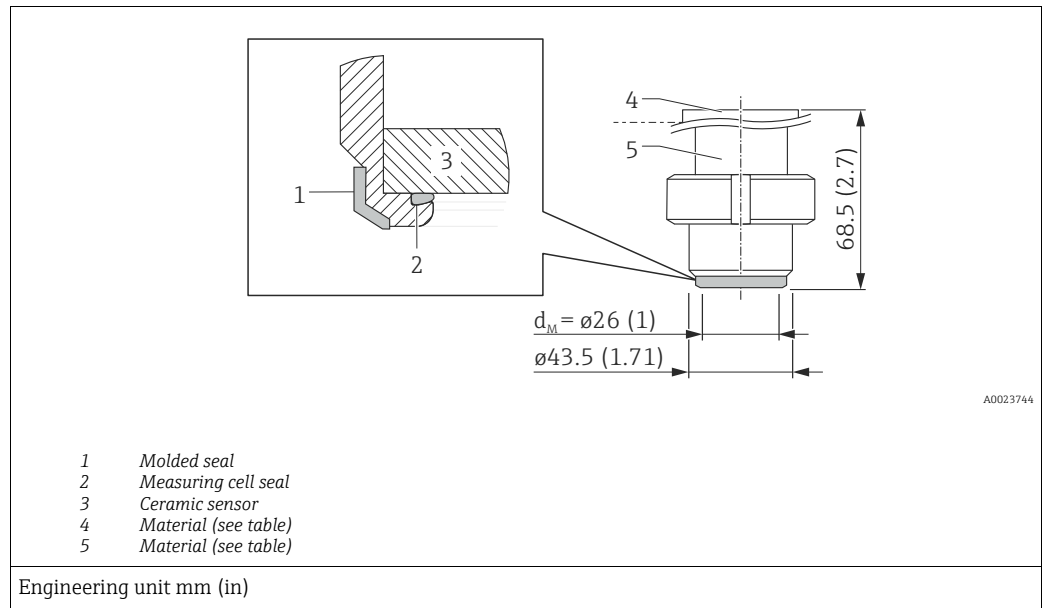

Designation	Nominal pressure	Material <sup>1)2)</sup>	Weight [kg/lbs]	Approval Process connection <sup>3)</sup>	Option <sup>4)</sup>
Universal adapter with pre-installed silicone molded seal	PN 10	<ul style="list-style-type: none"> <li>■ 4: top section AISI 316L (1.4404)</li> <li>■ 5: bottom section AISI 316L (1.4435)</li> </ul>	0.74 (1.63)	EHEDG, 3A with seal FDA, ASME-BPE	UPJ
Universal adapter with pre-installed EPDM molded seal				EHEDG, 3A, ASME-BPE	UNJ

- 1) The roughness of the surface in contact with the medium is  $R_a$  0.76  $\mu$ m (30  $\mu$ in).
- 2) Endress+Hauser supplies these slotted nuts in stainless steel AISI 304 (1.4301) or in AISI 304L (1.4307).
- 3) EHEDG or 3A approval only with approved process connection.
- 4) Product Configurator, "Process connection" ordering feature

Material of the molded seal (changeable seal)	Material of the measuring cell seal at the ceramic sensor (seal not changeable)	Approval of measuring cell seal	Option <sup>1)</sup>
Silicone (Spare part order no.: 52023572)	EPDM	FDA <sup>2)</sup> 3A Class II, USP Class VI, DVGW, KTW, W270, WRAS, ACS, NSF61	K
EPDM (Spare part order no.: 71100719)	EPDM	FDA <sup>2)</sup>	J

- 1) Product Configurator, "Seal" ordering feature
- 2) Suitable for foods FDA 21 CFR 177.2600

**PMP51: process connections with internal process isolating diaphragm**      **ISO 228 G threaded connection**

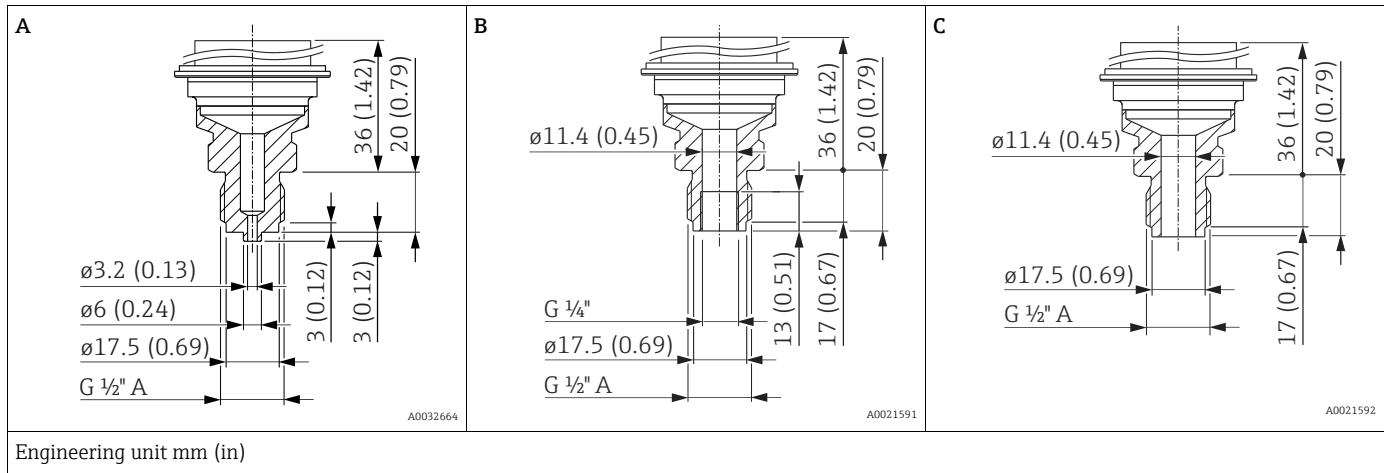

Item	Designation	Material	Weight kg (lbs)	Option <sup>1)</sup>
A	Thread ISO 228 G 1/2" A EN 837	AISI 316L	0.63 (1.39)	GCJ
		Alloy C276 (2.4819)		GCC
B	Thread ISO 228 G 1/2" A G 1/4" (female)	AISI 316L		GLJ
		Alloy C276 (2.4819)		GLC
C	Thread ISO 228 G 1/2" A, Bore 11.4 mm (0.45 in)	AISI 316L		GMJ
		Alloy C276 (2.4819)		GMC

1) Product Configurator, "Process connection" ordering feature

**DIN 13 threaded connection**

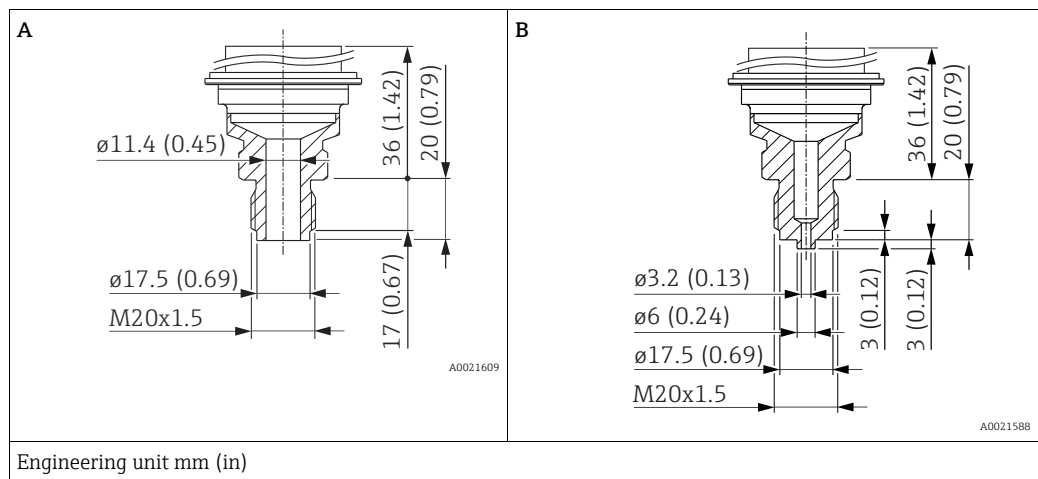

Item	Designation	Material	Weight kg (lbs)	Option <sup>1)</sup>
A	DIN 13 M20 x 1,5 Bore 11.4 mm (0.45 in)	AISI 316L	0.6 (1.32)	G1J
		Alloy C276 (2.4819)		G2J
B	DIN 13 M20 x 1,5, EN 837, Bore 3 mm (0.12 in)	AISI 316L		G5J
		Alloy C276 (2.4819)		G6J

1) Product Configurator, "Process connection" ordering feature

**PMP51: process connections    ANSI threaded connection  
with internal process  
isolating diaphragm**

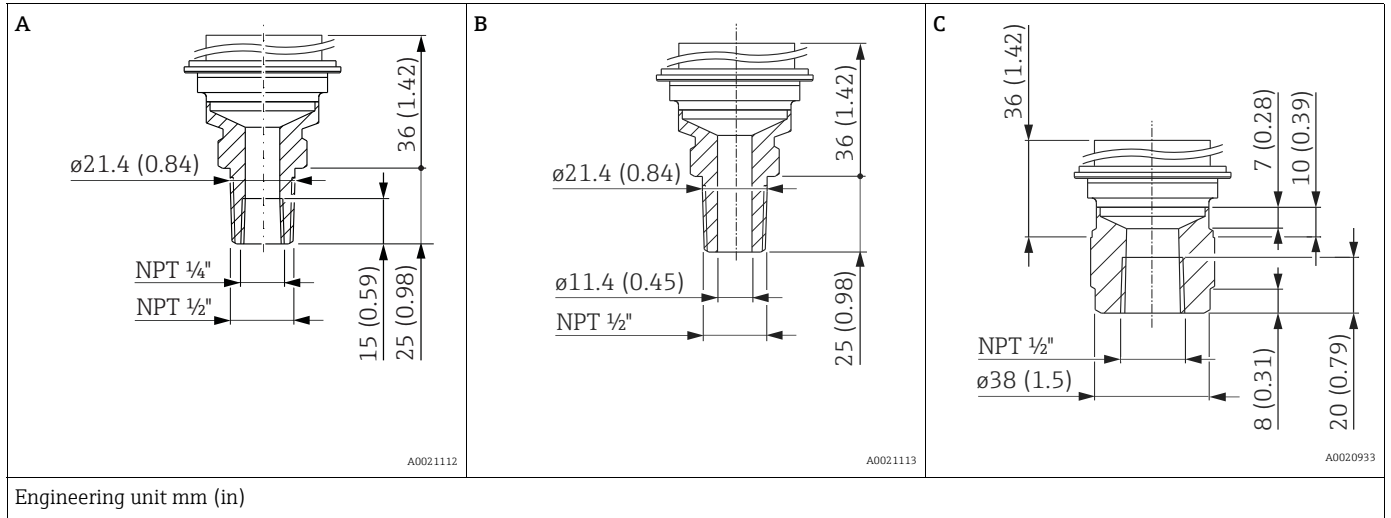

Item	Designation	Material	Weight kg (lbs)	Approval <sup>1)</sup>	Option <sup>2)</sup>
A	ANSI 1/2" MNPT, 1/4" FNPT	AISI 316L	0.63 (1.39)	CRN	RLJ
		Alloy C276 (2.4819)		CRN	RLC
B	ANSI 1/2" MNPT, Bore 11.4 mm (0.45 in) (400 bar (6000 psi))	AISI 316L	0.63 (1.39)	CRN	RKJ
		Alloy C276 (2.4819)		CRN	RKC
C	ANSI 1/2" FNPT	AISI 316L	0.7 (1.54)	CRN	R1J
		Alloy C276 (2.4819)		CRN	R1C

- 1) CSA approval: Product Configurator, "Approval" ordering feature
- 2) Product Configurator, "Process connection" ordering feature

**PMP51: process connections with flush-mounted process isolating diaphragm**      **ISO 228 G threaded connection**

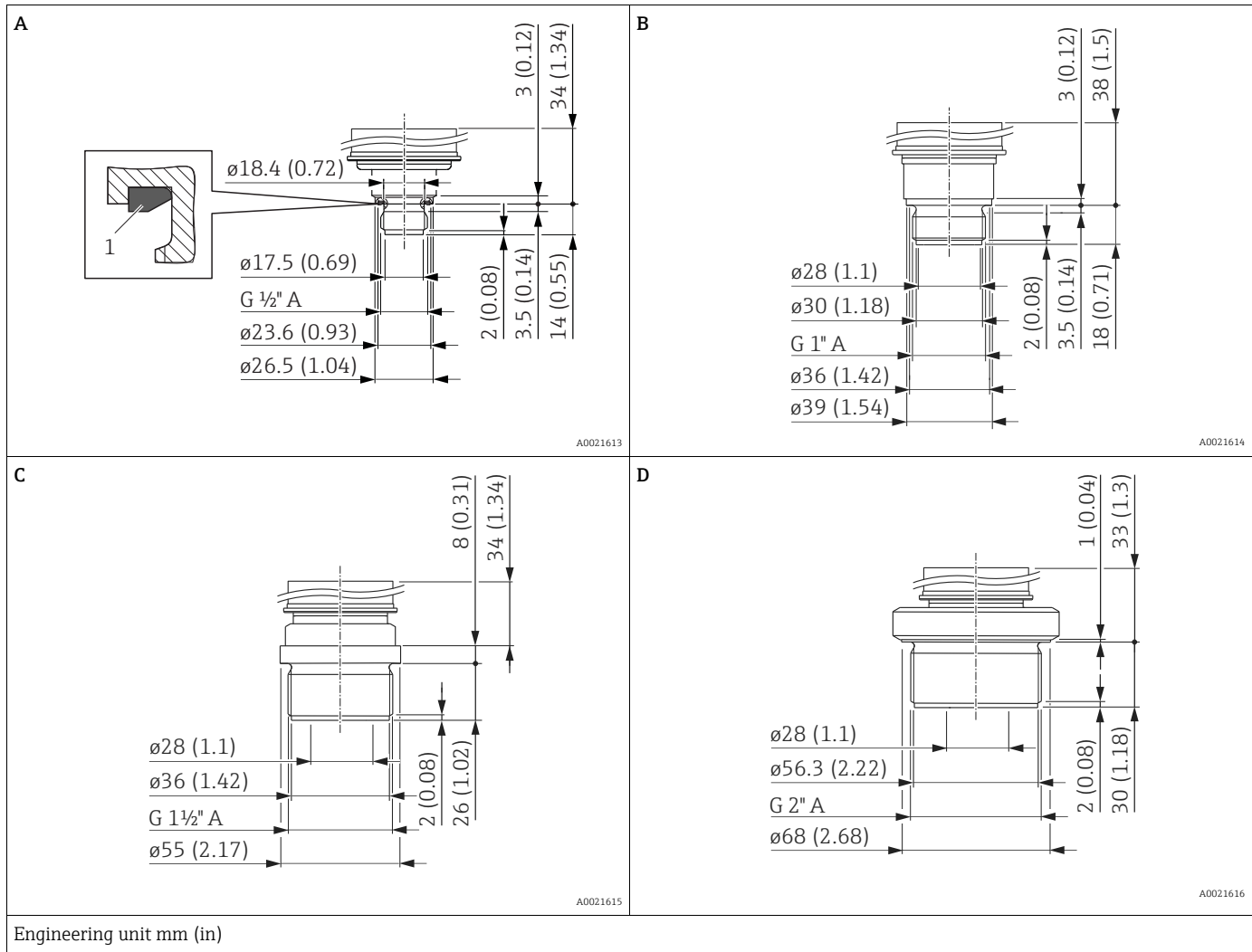

Item	Designation	Material	Weight kg (lbs)	Option <sup>1)</sup>
A	Thread ISO 228 G 1/2" A DIN 3852 FKM seal (item 1) pre-installed	AISI 316L	0.4 (0.88)	GRJ
		Alloy C276 (2.4819)		GRC
B	Thread ISO 228 G 1" A	AISI 316L	0.7 (1.54)	GTJ
C	Thread ISO 228 G 1 1/2" A	AISI 316L	1.1 (2.43)	GVJ
D	Thread ISO 228 G 2" A	AISI 316L	1.5 (3.31)	GWJ

1) Product Configurator, "Process connection" ordering feature

**PMP51: process connections with flush-mounted process isolating diaphragm**

**DIN 13 threaded connection**

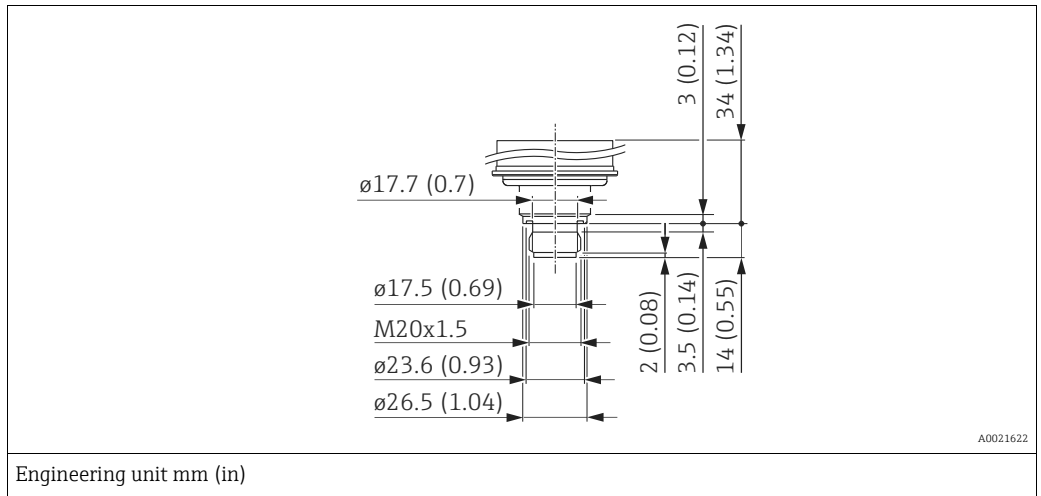

Designation	Material	Weight kg (lbs)	Option <sup>1)</sup>
DIN 13 M20 x 1,5	AISI 316L	0.6 (1.32)	G7J
	Alloy C276 (2.4819)		G8J

1) Product Configurator, "Process connection" ordering feature

**PMP51: process connections with flush-mounted process isolating diaphragm**

**ANSI threaded connection**

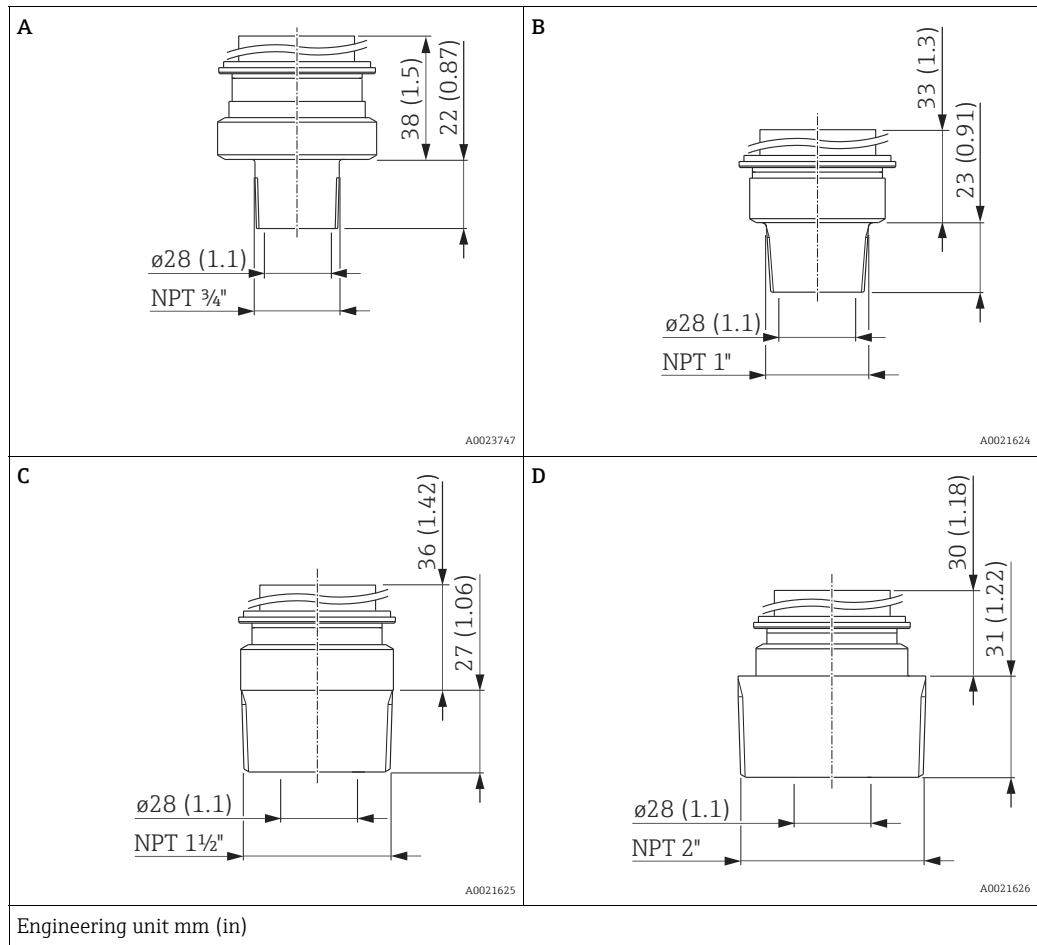

Item	Designation	Material	Weight kg (lbs)	Approval <sup>1)</sup>	Option <sup>2)</sup>
A	ANSI 3/4" MNPT	AISI 316L	0.6 (1.32)	-	U4J
B	ANSI 1" MNPT		0.7 (1.54)	CRN	U5J
C	ANSI 1 1/2" MNPT		1 (2.21)	CRN	U7J
D	ANSI 2" MNPT		1.3 (2.87)	CRN	U8J

1) CSA approval: Product Configurator, "Approval" ordering feature

2) Product Configurator, "Process connection" ordering feature



**PMP51: process connections with flush-mounted process isolating diaphragm**

**EN/DIN flanges, connection dimensions as per EN 1092-1/DIN 2527**

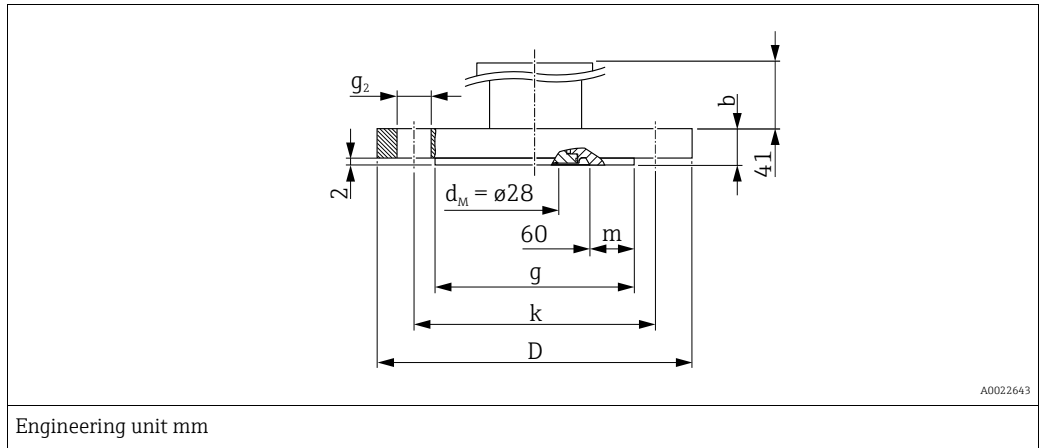

Flange <sup>1)</sup>						Boltholes				Flange weight	Option <sup>2)</sup>
Nominal diameter	Nominal pressure	Shape <sup>3)</sup>	D	Thickness b	Raised face g	Width of the raised face (m)	Quantity	g <sub>2</sub>	Hole circle k		
			[mm]	[mm]	[mm]	[mm]		[mm]	[mm]	[kg (lbs)]	
DN 25	PN 10-40	B1 (D)	115	18	68 <sup>4)</sup>	4	4	14	85	1.2 (2.65)	CNJ
DN 32	PN 10-40	B1 (D)	140	18	78 <sup>4)</sup>	9	4	18	100	1.9 (4.19)	CPJ
DN 40	PN 10-40	B1 (D)	150	18	88 <sup>4)</sup>	14	4	18	110	2.2 (4.85)	CQJ
DN 50	PN 10-40	B1 (D)	165	20	102	-	4	18	125	3.0 (6.62)	CXJ
DN 80	PN 10-40	B1 (D)	200	24	138	-	8	18	160	5.3 (11.69)	CZJ

- 1) Material: AISI 316L
- 2) Product Configurator, "Process connection" ordering feature
- 3) Designation as per DIN 2527 in brackets
- 4) With these process connections the raised face is smaller than described in the standard. Due to the smaller raised face a special seal must be used. Contact a seal manufacturer or your local Endress+Hauser Sales Center.

**PMP51: process connections with flush-mounted process isolating diaphragm**

**ASME flanges, connection dimensions as per ASME B 16.5, raised face RF\***

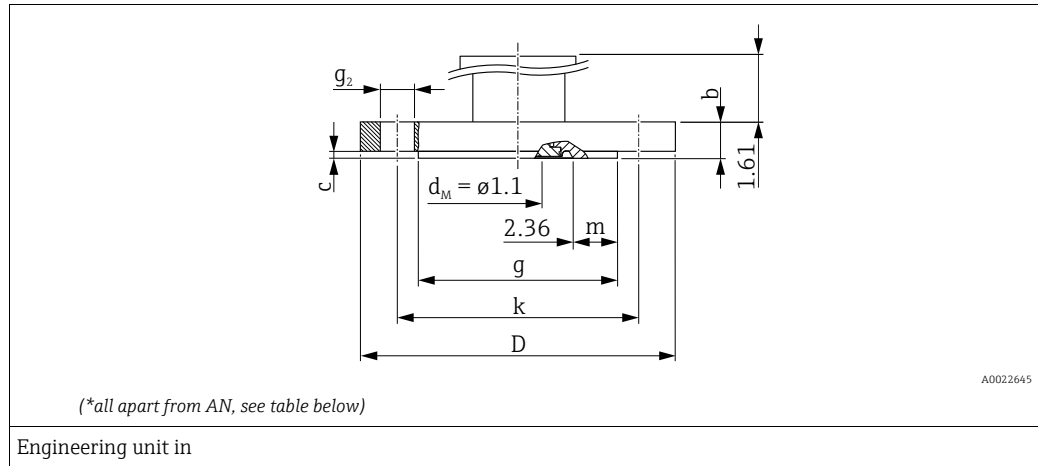

Flange <sup>1)</sup>							Boltholes			Weight	Approval <sup>2)</sup>	Option <sup>3)</sup>
Nominal diameter	Class/ Nominal pressure	D	Thickness	Diameter of raised face	Thickness of raised face	Width of raised face	Quantity	g <sub>2</sub>	Hole circle			
[in]	[lb./sq.in]	[in]	b [in]	g [in]	c [in]	(m) [in]		[in]	k [in]	[kg (lbs)]		
1	300	4.88	0.69	2 <sup>4)</sup>	0.06	0.2	4	0.75	3.5	1.3 (2.87)	CRN	ANJ
1 ½	150	5	0.69	2.88 <sup>4)</sup>	0.08	0.52	4	0.62	3.88	1.5 (3.31)	CRN	AEJ
1 ½	300	6.12	0.81	2.88 <sup>4)</sup>	0.08	0.52	4	0.88	4.5	2.6 (5.73)	CRN	AQJ
2	150	6	0.75	3.62	0.08	-	4	0.75	4.75	2.4 (5.29)	CRN	AFJ
2	300	6.5	0.88	3.62	0.08	-	8	0.75	5	3.2 (7.06)	CRN	ARJ
3	150	7.5	0.94	5	0.08	-	4	0.75	6	4.9 (10.8)	CRN	AGJ
3	300	8.25	1.12	5	0.08	-	8	0.88	6.62	6.7 (14.77)	CRN	ASJ
4	150	9	0.94	6.19	0.08	-	8	0.75	7.5	7.1 (15.66)	CRN	AHJ
4	300	10	1.25	6.19	0.08	-	8	0.88	7.88	11.6 (25.88)	CRN	ATJ

- 1) Material: AISI 316/316L; combination of AISI 316 for required pressure resistance and AISI 316L for required chemical resistance (dual rated)
- 2) CSA approval: Product Configurator, "Approval" ordering feature
- 3) Product Configurator, "Process connection" ordering feature
- 4) With these process connections the raised face is smaller than described in the standard. Due to the smaller raised face a special seal must be used. Contact a seal manufacturer or your local Endress+Hauser Sales Center.

**PMP51: hygienic process connections with flush-mounted process isolating diaphragm**

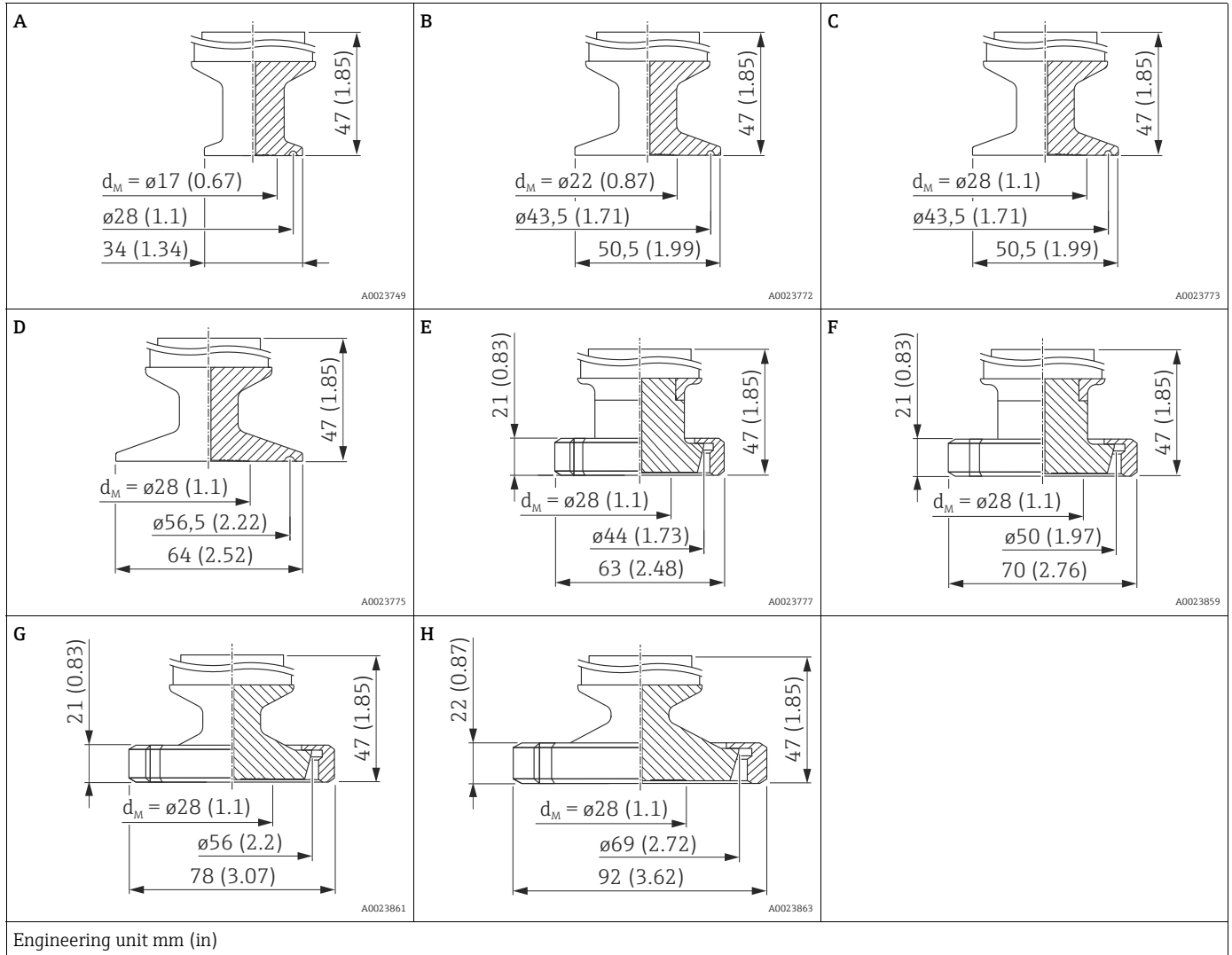

Item <sup>1) 2)</sup>	Designation	Nominal pressure	Weight kg (lbs)	Approval	Option <sup>3)</sup>
A	Clamp ISO2852, DN 18-22, DIN 32676 DN 15-20	PN 40	0.5 (1.10)	EHEDG, 3A, ASME-BPE	TBJ
B	Tri-Clamp ISO2852 DN 25 (1"), DIN 32676 DN 25	PN 40	0.6 (1.32)	EHEDG, 3A, ASME-BPE	TCJ
C	Tri-Clamp ISO2852 DN 38 (1½"), DIN 32676 DN 40	PN 40	0.6 (1.32)	EHEDG, 3A, ASME-BPE	TJJ
D	Tri-Clamp ISO2852 DN 40-51 (2"), DIN 32676 DN 50	PN 40	0.7 (1.54)	EHEDG, 3A, ASME-BPE	TDJ
E	DIN 11851 DN 25	PN 25	0.7 (1.54)	EHEDG, 3A, ASME-BPE	MXJ
F	DIN 11851 DN 32	PN 25	0.8 (1.76)	EHEDG, 3A, ASME-BPE	MIJ
G	DIN 11851 DN 40	PN 25	0.9 (1.98)	EHEDG, 3A, ASME-BPE	MZJ
H	DIN 11851 DN 50	PN 25	1.1 (2.43)	EHEDG, 3A, ASME-BPE	MRJ

1) Material: AISI 316L (1.4435)

2) The roughness of the surface in contact with the medium is  $R_a$  0.76  $\mu$ m (30  $\mu$ in). Version optionally in conformity with ASME-BPE for use in biochemical processes, wetted surfaces  $R_a$  0.38  $\mu$ m (15  $\mu$ in), electropolished; to be ordered using order feature 570 "Service", option "HK" in the order code.

3) Product Configurator, "Process connection" ordering feature

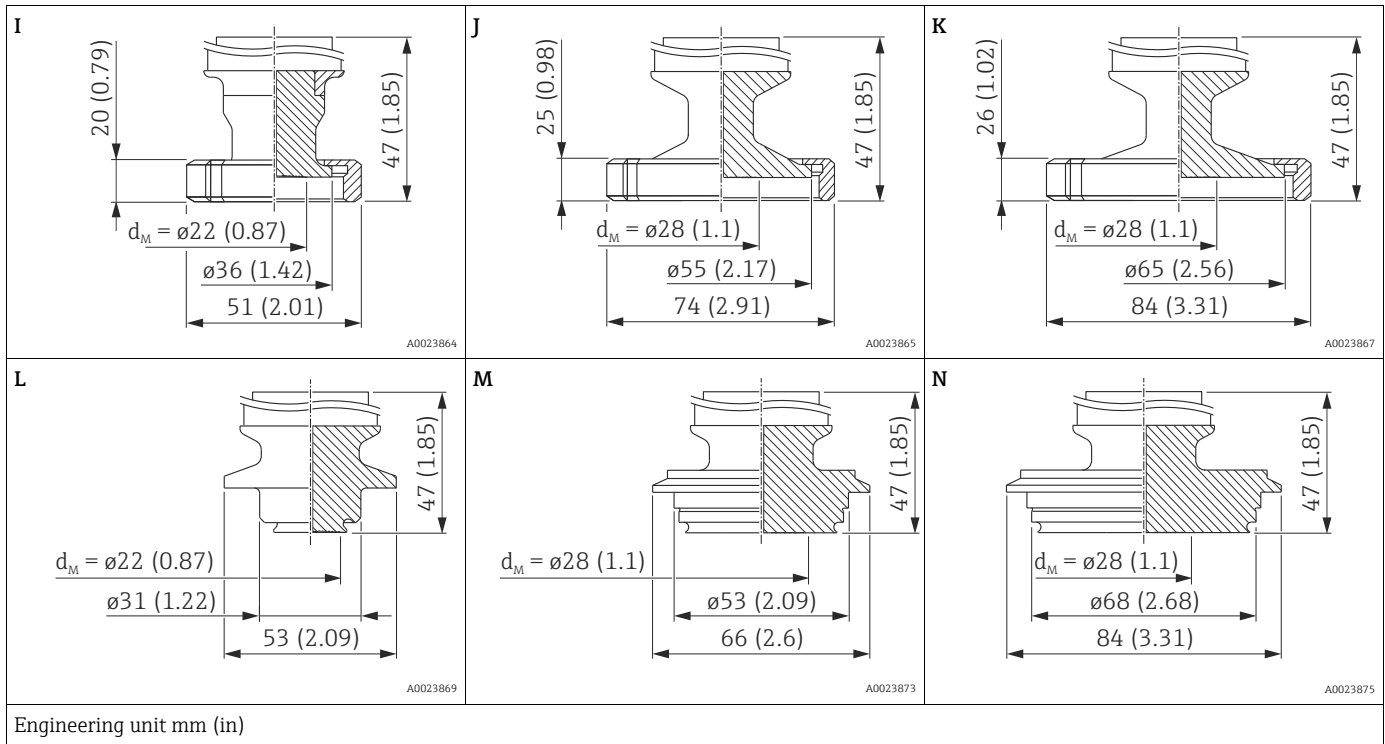

Item <sup>1) 2)</sup>	Designation	Nominal pressure	Weight	Approval	Option <sup>3)</sup>
			kg (lbs)		
I	SMS 1"	PN 25	0.7 (1.54)	EHEDG, 3A, ASME-BPE	T6J
J	SMS 1½"	PN 25	0.8 (1.76)	EHEDG, 3A, ASME-BPE	T7J
K	SMS 2"	PN 25	0.9 (1.98)	EHEDG, 3A, ASME-BPE	TXJ
L	Varivent B pipe DN 10-15	PN 40	0.7 (1.54)	EHEDG, 3A, ASME-BPE	TPJ
M	Varivent F pipe DN 25-32	PN 40	0.9 (1.98)	EHEDG, 3A, ASME-BPE	TQJ
N	Varivent N pipe DN 40-162	PN 40	1.1 (2.43)	EHEDG, 3A, ASME-BPE	TRJ

1) Material: AISI 316L (1.4435)

2) The roughness of the surface in contact with the medium is  $R_a$  0.76  $\mu$ m (30  $\mu$ m). Version optionally in conformity with ASME-BPE for use in biochemical processes, wetted surfaces  $R_a$  0.38  $\mu$ m (15  $\mu$ m), electropolished; to be ordered using order feature 570 "Service", option "HR" in the order code.

3) Product Configurator, "Process connection" ordering feature

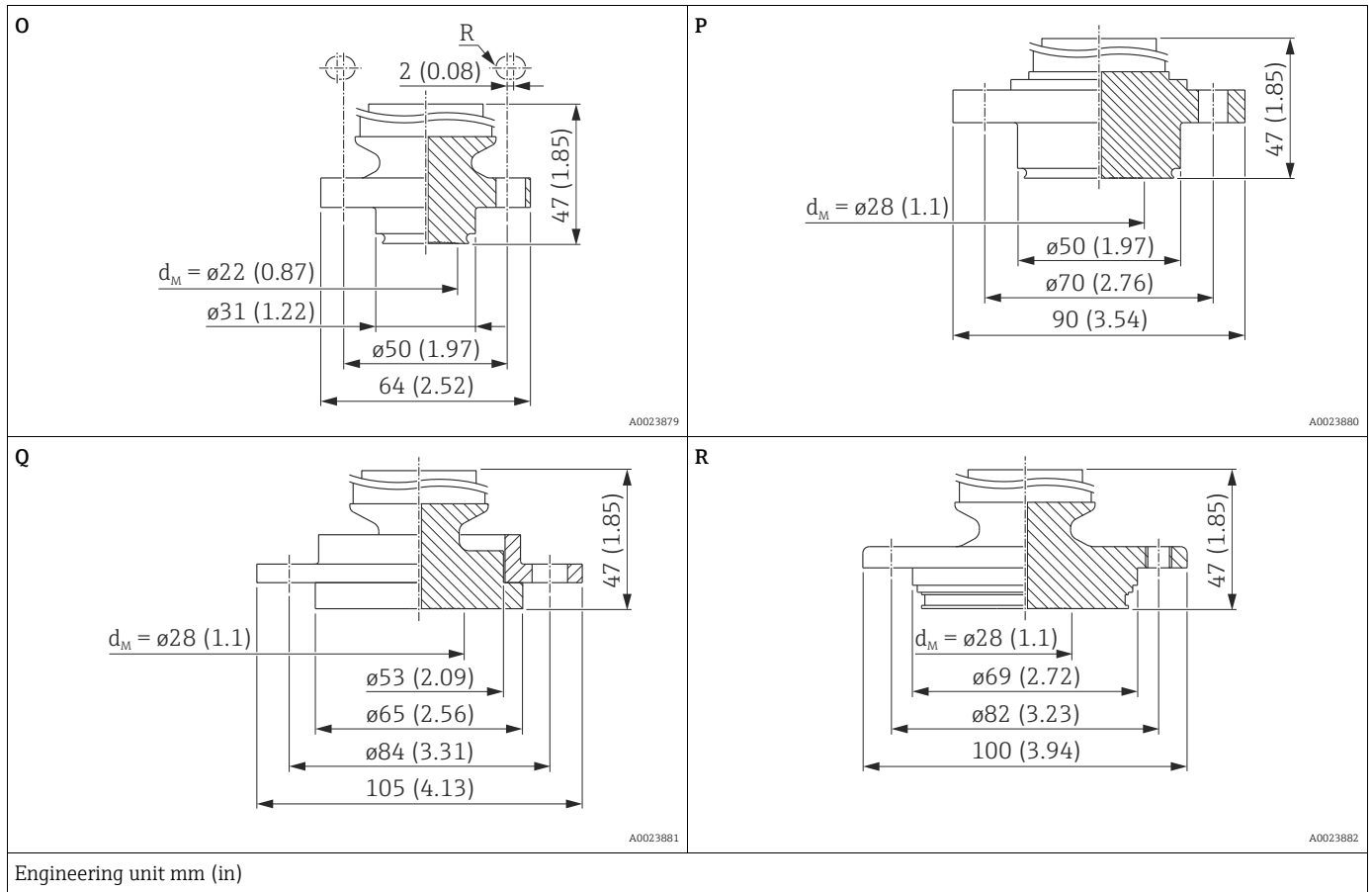

Item <sup>1) 2)</sup>	Designation	Nominal pressure	Boltholes		Weight kg (lbs)	Approval	Option <sup>3)</sup>
			Quantity	Diameter			
O	NEUMO BioControl D 25	PN 16	4	R: 3.5 mm (0.14 in)	0.8 (1.76)	EHEDG, 3A, ASME-BPE	S1J
P	NEUMO BioControl D 50	PN 16	4	9 mm (0.35 in)	1.2 (2.65)	EHEDG, 3A, ASME-BPE	S4J
Q	DRD DN 50	PN 25	4	11.5 mm (0.45 in)	1.0 (2.21)	-	TIJ
R	APV Inline DN 50	PN 40	6	8.6 mm (0.34 in)	1.2 (2.65)	EHEDG, 3A, ASME-BPE	TMJ
			2	M8			

- 1) Material: AISI 316L (1.4435)
- 2) The roughness of the surface in contact with the medium is  $R_a$  0.76  $\mu\text{m}$  (30  $\mu\text{in}$ ). Version optionally in conformity with ASME-BPE for use in biochemical processes, wetted surfaces  $R_a$  0.38  $\mu\text{m}$  (15  $\mu\text{in}$ ), electropolished; to be ordered using order feature 570 "Service", option "HK" in the order code.
- 3) Product Configurator, "Process connection" ordering feature

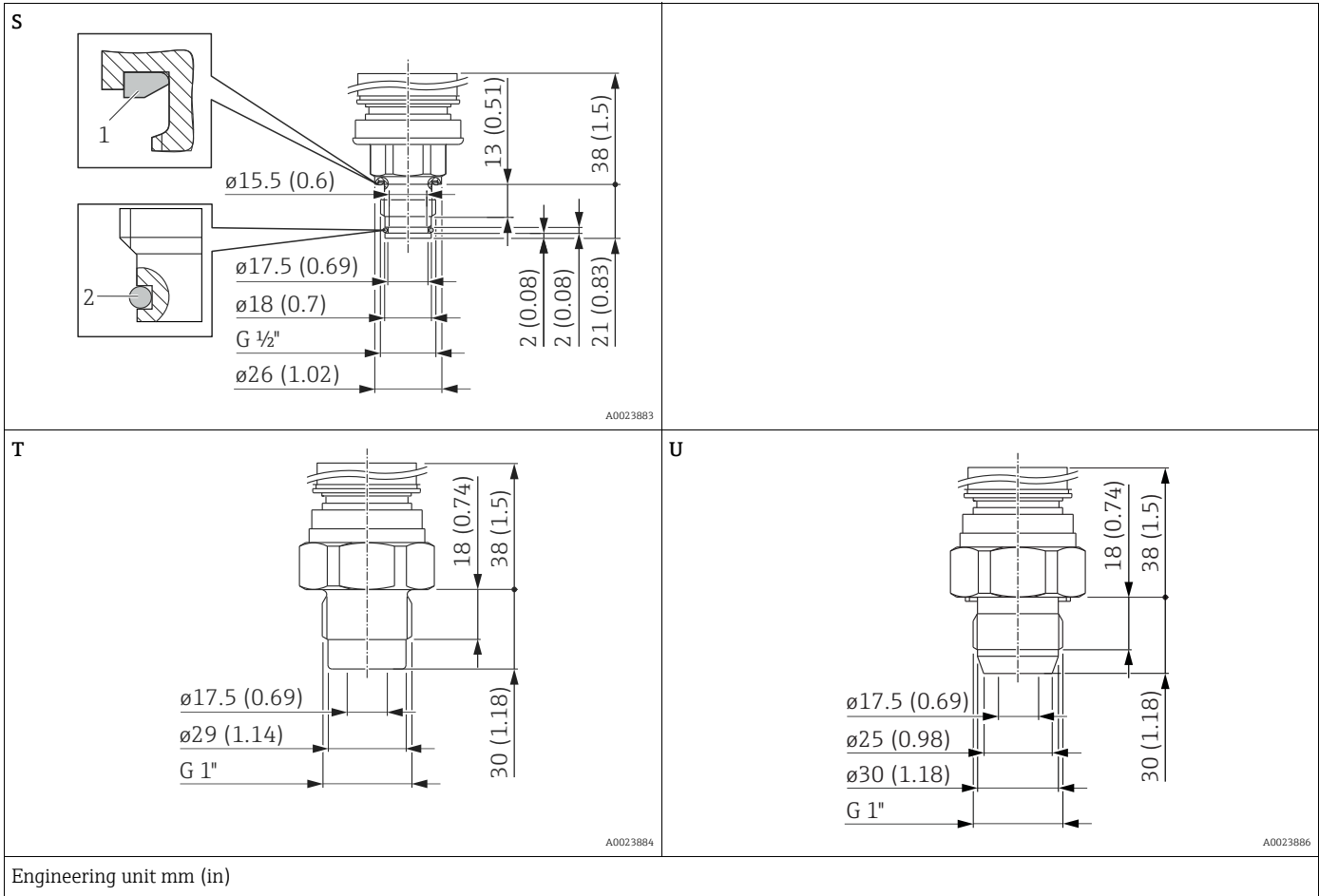

Item <sup>1) 2)</sup>	Designation	Seal		Nominal pressure	Weight kg (lbs)	Approval	Option <sup>3)</sup>
		Item	Designation				
S	Thread ISO228 G 1/2"	1	FKM molded seal pre-installed	PN 40	0.5 (1.1)	ASME-BPE	GOJ
		2	FKM O-ring pre-installed				
T	Thread ISO228 G1"	-	Sealing via O-ring. VMQ O-ring included with the accessories QE and QF.	PN 40	0.8 (1.76)	3A, ASME-BPE	GZJ <sup>4)</sup>
U	Thread ISO228 G1"	1	Metall joint	PN 100	0.8 (1.76)	ASME-BPE	GXJ

1) Material: AISI 316L

2) The roughness of the surface in contact with the medium is  $R_a$  0.76  $\mu$ m (30  $\mu$ in). Version optionally in conformity with ASME-BPE for use in biochemical processes, wetted surfaces  $R_a$  0.38  $\mu$ m (15  $\mu$ in), electropolished; to be ordered using order feature 570 "Service", option "HK" in the order code.

3) Product Configurator, "Process connection" ordering feature

4) EHEDG in combination with EHEDG certified process- or weld in adapter; details see TI00426F.

**Valve manifold DA63M (optional)**

Endress+Hauser supplies milled valve manifolds via the transmitter's product structure in the following versions:

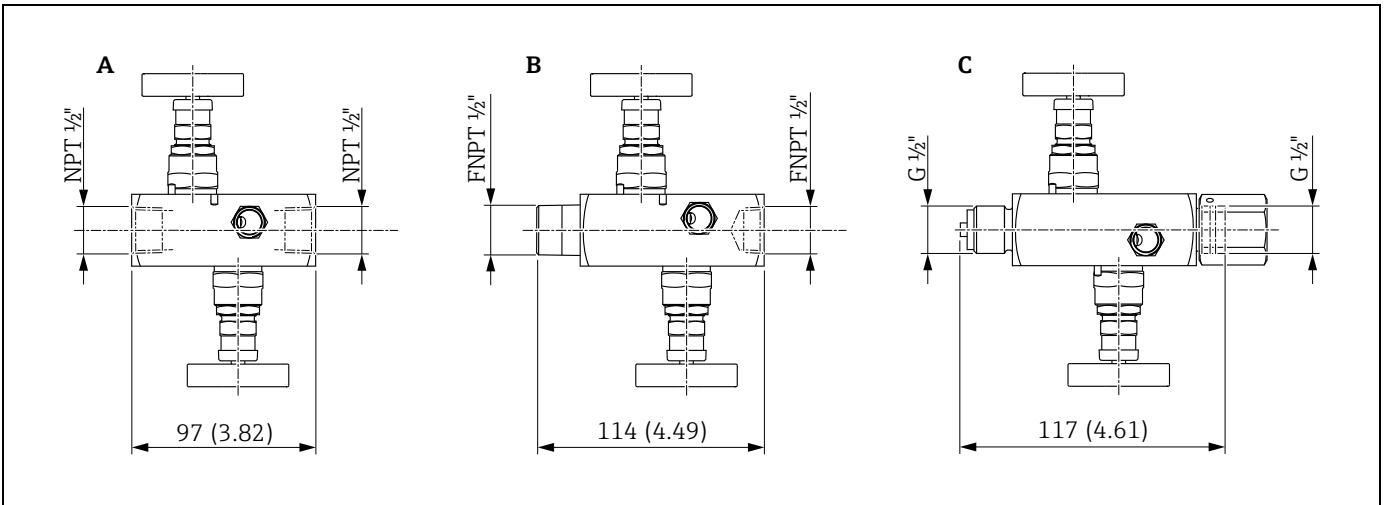

Engineering unit mm (in)

- A 2-way valve manifold FNPT x FNPT
- B 2-way valve manifold MNPT x FNPT
- C 2-way valve manifold G 1/2" + adjusting nut

2-way valve manifolds in 316L or AlloyC can be

- ordered as an **enclosed** accessory (seal for mounting is enclosed)
- ordered as a **mounted** accessory (mounted valve manifolds are supplied with a documented leakage test).

Certificates ordered with the equipment (e.g. 3.1 material certificate and NACE) and tests (e.g. PMI and pressure test) apply to the transmitter and the valve manifold.

For other details (order option, dimension, weight, materials), see SD01553P/00/EN "Mechanical accessories for pressure measuring devices".

During the operating life of the valves, it may be necessary to re-tighten the packing.

**Mounting on valve manifold**

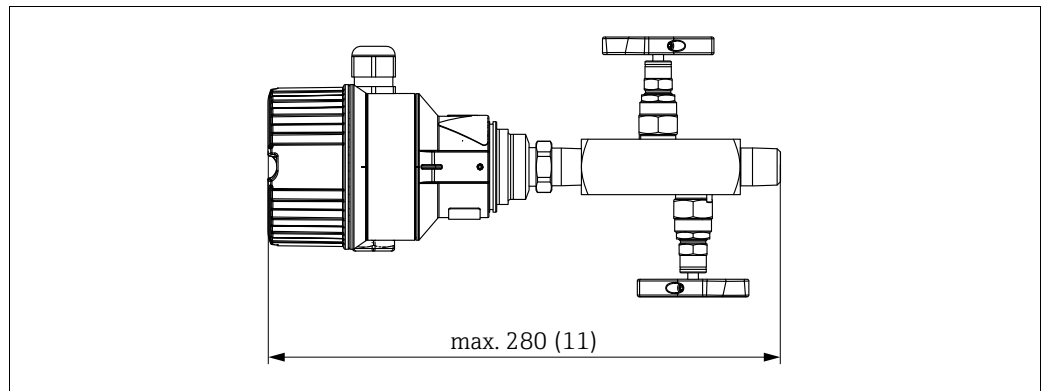

Engineering unit mm (in)

Ordering information:

Product Configurator, order code for "Accessories mounted".

**PMP51: process connections**      **Prepared for diaphragm seal mount**

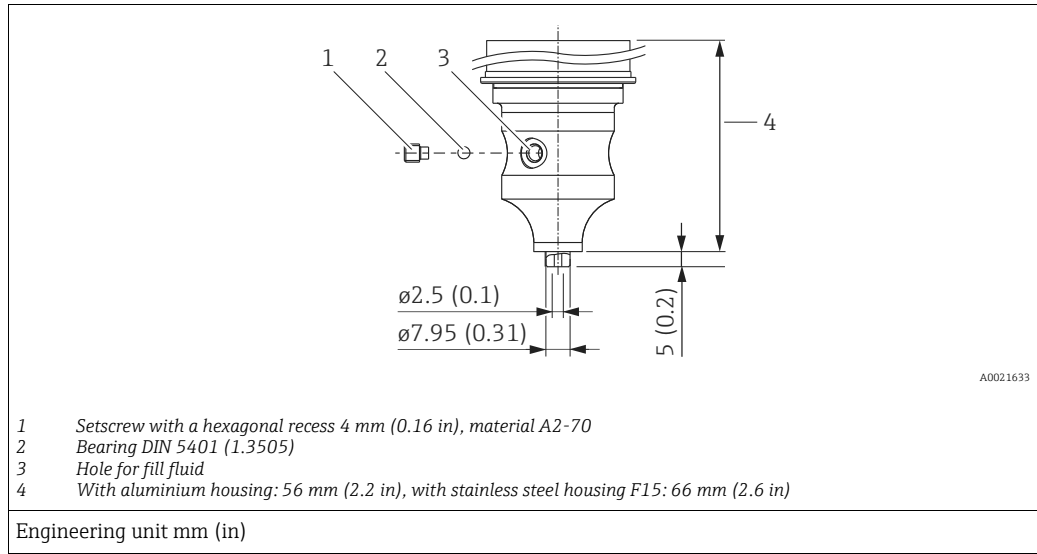

Material	Designation	Weight kg (lbs)	Approval <sup>1)</sup>	Option <sup>2)</sup>
AISI 316L (1.4404)	Prepared for diaphragm seal mount	1.9 (4.19)	CRN	XSJ

- 1)      CSA approval: Product Configurator, “Approval” ordering feature
- 2)      Product Configurator, “Process connection” ordering feature



**PMP55 basic device - examples**

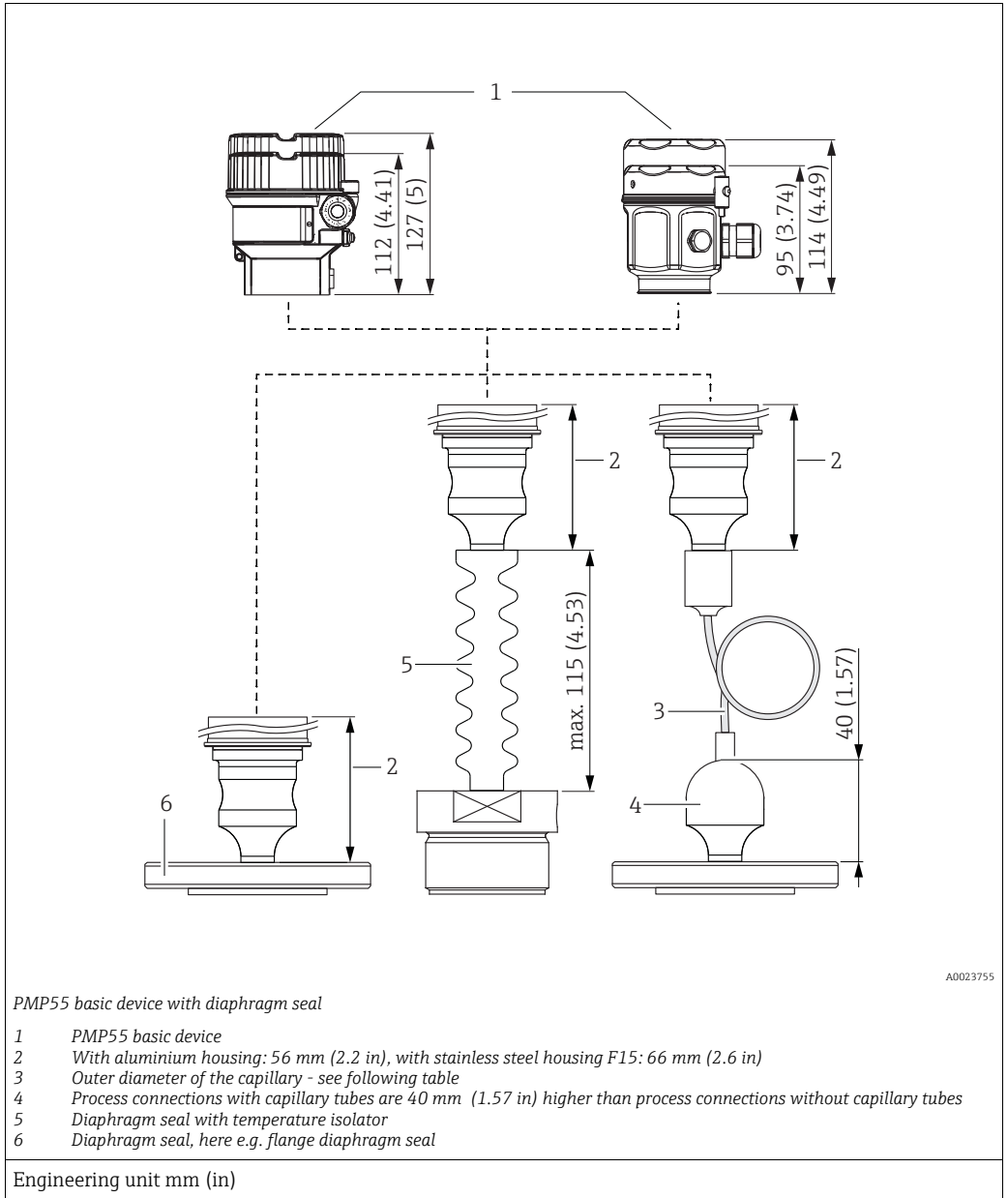

**Outer diameter of capillary**

Designation	Outer diameter
Flexible armor made from 316L	8 mm (0.31 in)
Flexible armor with PVC-coating	10 mm (0.39 in)
Flexible armor with PTFE-coating	12,5 mm (0.49 in)

**Diaphragm seal connection**

Designation	Option <sup>1)</sup>
Direct	A
Temperature isolator	B
..... m capillary	D
..... ft capillary	E

1) Product Configurator, "Diaphragm seal connection" ordering feature

**PMP55: process connections with flush-mounted process isolating diaphragm**



- The weights of the diaphragm seals are given in the tables. See → 45 ff for the weight of the housing.
- The following drawings are schematic diagrams. In other words, the dimensions of a diaphragm seal supplied may deviate from the dimensions given in this document.
- When using high-temperature oils the design can deviate significantly.
- Observe the information in the "Planning instructions for diaphragm seal systems" ordering feature → 107 ff.
- For further information please contact your local Endress+Hauser Sales Center.

**Diaphragm seal cell structure (Pancake)**

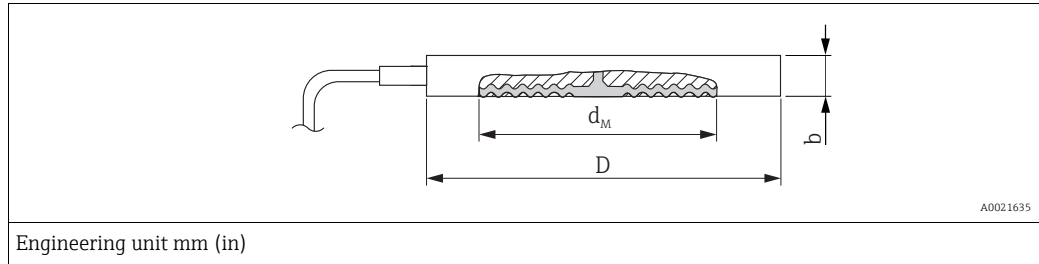

Flange					Diaphragm seal		Approval <sup>1)</sup>	Option <sup>2)</sup>
Material	Nominal diameter	Nominal pressure <sup>3)</sup>	Max. Diameter D	Thickness b	Max. diameter of the process isolating diaphragm d <sub>M</sub>	Weight		
			[mm]	[mm]	[mm]	[kg (lbs)]		
AISI 316L	DN 50	PN 16-400	102	20	59	1.3 (2.87)	-	UIJ
	DN 80	PN 16-400	138	20	89	2.3 (5.07)	-	UJJ
	DN 100	PN 16-400	162	20	89	3.1 (6.84)	-	UKJ
	[in]	[lb/sq.in]	[in (mm)]	[in (mm)]	[in (mm)]	[kg]		
	2	150-2500	4.01 (102)	0.79 (20)	2.32 (59)	1.3 (2.87)	CRN	ULJ
	3	150-2500	5.35 (136)	0.79 (20)	3.50 (89)	2.3 (5.07)	CRN	UMJ
	4	150-2500	6.22 (158)	0.79 (20)	3.50 (89)	3.1 (6.84)	CRN	URJ

- 1) CSA approval: Product Configurator, "Approval" ordering feature
- 2) Product Configurator, "Process connection" ordering feature
- 3) The specified nominal pressure applies to the diaphragm seal. The maximum pressure for the measuring device is dependent on the lowest-rated element, with regard to pressure, of the selected components (see also → 44, "Pressure specifications" ordering feature).

**PMP55: process connections with flush-mounted process isolating diaphragm** Thread ISO 228 and ANSI

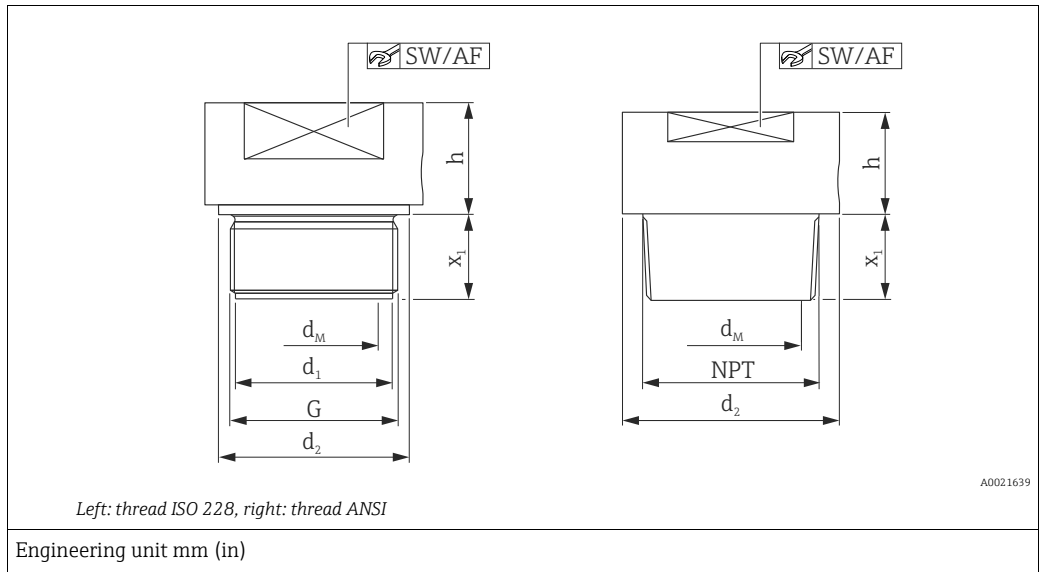

Threaded connection							Diaphragm seal			Approval <sup>1)</sup>	Option <sup>2)</sup>
Material	Thread	Nominal pressure PN	Diameter d <sub>1</sub> [mm]	Diameter d <sub>2</sub> [mm]	Screw-in length x <sub>1</sub> [mm]	Across flats SW/AF	Max. diaphragm diameter d <sub>M</sub> [mm]	Height h [mm]	Weight [kg (lbs)]		
AISI 316L	G 1" A	400	30	39	21 <sup>3)</sup>	41	30	19	0.4 (0.88)	-	GTJ
Alloy C276									0.5 (1.1)	-	GTC
AISI 316L	G 1 ½" A	400	44	55	30	50	42	20	0.9 (1.98)	-	GVJ
Alloy C276									1.0 (2.21)	-	GVC
AISI 316L	G 2"	400	56	68	30	65	50	20	1.9 (4.19)	-	GWJ
Alloy C276									2.1 (4.63)	-	GWC
AISI 316L	1" MNPT	400	-	48	28	41	24	37	0.6 (1.32)	CRN	U5J
Alloy C276									0.7 (1.54)	CRN	U5C
AISI 316L	1 ½" MNPT	400	-	60	30	41	36	20	0.9 (1.98)	CRN	U7J
Alloy C276									1.0 (2.21)	CRN	U7C
AISI 316L	2" MNPT	400	-	78	30	65	38	35	1.8 (3.97)	CRN	U8J
Alloy C276									2.0 (4.41)	CRN	U8C

- 1) CSA approval: Product Configurator, "Approval" ordering feature
- 2) Product Configurator, "Process connection" ordering feature
- 3) 28 mm (1.1 in) in conjunction with high-temperature oil

**PMP55: process connections with flush-mounted process isolating diaphragm**

**Tri-Clamp ISO 2852**

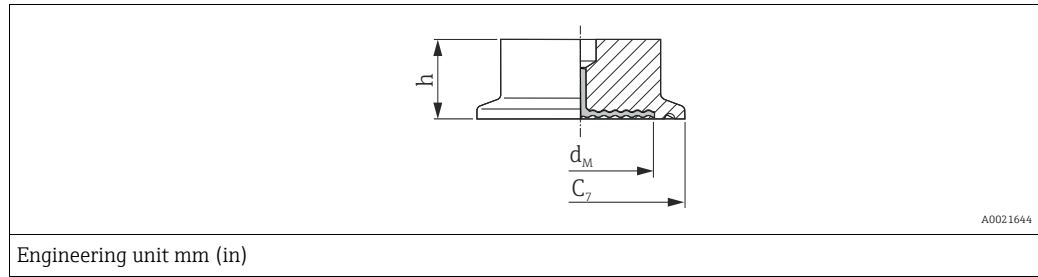

Material <sup>1)</sup>	Nominal diameter ISO 2852	Nominal diameter DIN 32676	Nominal diameter [in]	Diameter C <sub>7</sub> [mm]	Max. diaphragm diameter		Height h [mm]	Weight [kg (lbs)]	Approval <sup>2)</sup>	Option <sup>3)</sup>
					Standard d <sub>M</sub> [mm]	With TempC diaphragm d <sub>M</sub> [mm]				
AISI 316L	ND 25 / 33.7	DN 25	1	50.5	24	-	37	0.32 (0.71)	EHEDG, 3A, CRN, ASME-BPE	TCJ
	ND 38	DN 40	1 ½	50.5	36	36	30	1 (2.21)	EHEDG, 3A, CRN, ASME-BPE	TJJ <sup>4) 5)</sup>
	ND 40 / 51	DN 50	2	64	48	41	30	1.1 (2.43)	EHEDG, 3A, CRN, ASME-BPE	TDJ <sup>4) 5)</sup>
	ND 63.5	-	2 ½	77.5	61	61	30	0.7 (1.54)	EHEDG, 3A, ASME-BPE	TEJ <sup>6)</sup>
	ND 76.1	-	3	91	73	61	30	1.2 (2.65)	EHEDG, 3A, CRN, ASME-BPE	TFJ <sup>5)</sup>

- 1) Surface roughness of the surfaces in contact with the medium  $R_a \leq 0.76 \mu\text{m}$  (29.9  $\mu\text{in}$ ) as standard. Lower surface roughness available on request.
- 2) CSA approval: Product Configurator, "Approval" ordering feature
- 3) Product Configurator, "Process connection" ordering feature
- 4) Process connections without TempC diaphragm: diaphragm seal versions optionally in conformity with ASME-BPE for use in biochemical processes, wetted surfaces  $R_a \leq 0.38 \mu\text{m}$  (0.15  $\mu\text{in}$ ), electropolished; ordering information: Product Configurator "Service" ordering feature, option HK.
- 5) Alternatively available with TempC diaphragm.
- 6) With TempC diaphragm



PN max. = 40 bar (580 psi)  
 The maximum PN depends on the used clamp.

**PMP55: process connections with flush-mounted process isolating diaphragm**

**Pipe diaphragm seal Tri-Clamp ISO 2852**

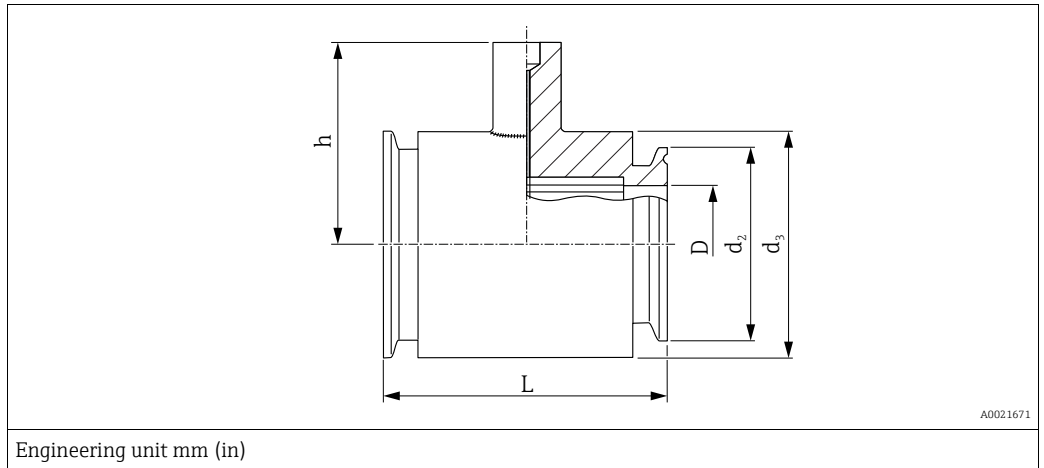

Engineering unit mm (in)

Material <sup>1)</sup>	Nominal diameter ISO 2852	Nominal diameter	Nominal pressure	Diameter	Diameter	Durchmesser	Height	Face-to-face length	Weight	Approval <sup>2)</sup>	Option <sup>3)</sup>
		[in]		D [in]	d <sub>2</sub> [mm]	d <sub>3</sub> [mm]	h [mm]	L [mm]	[kg (lbs)]		
AISI 316L	DN 25	1	PN 40	22.5	50.5	54	67	126	1.7 (3.75)	3A, CRN	SBJ
	DN 38	1 ½	PN 40	35.5	50.5	69	67	126	1.0 (2.21)	3A, CRN	SCJ <sup>4)</sup>
	DN 51	2	PN 40	48.6	64	78	79	100	1.7 (3.75)	3A, CRN	SDJ <sup>4)</sup>
	DN 10	¾	PN 40	10.3	25	34	42	138.5	0.6 (1.32)	3A, CRN	SJ

- 1) Surface roughness of the surfaces in contact with the medium  $R_a \leq 0.8 \mu\text{m}$  (31.5  $\mu\text{in}$ ) as standard.
- 2) CSA approval: Product Configurator, "Approval" ordering feature
- 3) Product Configurator, "Process connection" ordering feature
- 4) incl. 3.1 and pressure test according to Pressure Equipment Directive, Category II

**PMP55: hygienic process connections with flush-mounted process isolating diaphragm**

**Varivent for pipes**

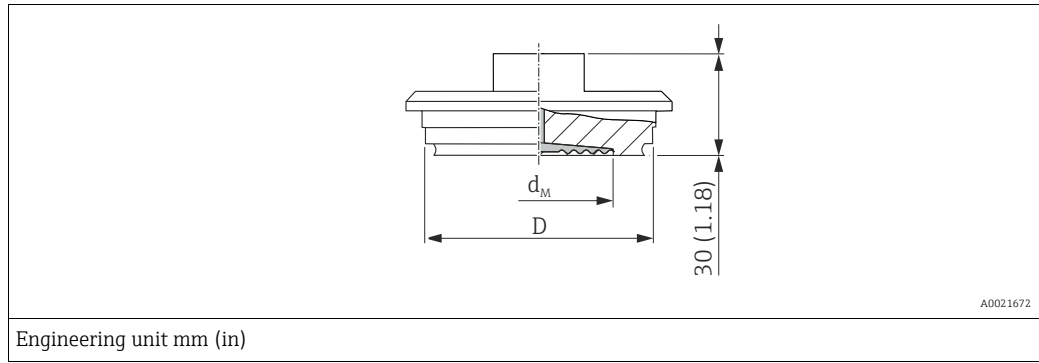

Material <sup>1)</sup>	Designation	Nominal pressure	Diameter	Max. diaphragm diameter		Weight	Approval	Option <sup>2)</sup>
				Standard	With TempC diaphragm			
			D	d <sub>M</sub> [mm]	d <sub>M</sub> [mm]	[kg (lbs)]		
AISI 316L	Type F for tubes DN 25 - DN 32	PN 40	50	34	36	0.4 (0.88)	EHEDG, 3A, ASME-BPE	TQJ <sup>3)</sup>
AISI 316L	Type N for tubes DN 40 - DN 162	PN 40	68	58	61	0.8 (1.76)	EHEDG, 3A, ASME-BPE	TRJ <sup>4)5)</sup>

- 1) Surface roughness of the surfaces in contact with the medium  $R_a \leq 0.76 \mu\text{m}$  (29.9  $\mu\text{in}$ ) as standard.
- 2) Product Configurator, "Process connection" ordering feature
- 3) Alternatively available with TempC diaphragm.
- 4) Diaphragm seal versions optionally in conformity with ASME-BPE for use in biochemical processes, wetted surfaces  $R_a \leq 0.38 \mu\text{m}$  (15  $\mu\text{in}$ ), electropolished; ordering information: Product Configurator "Service" ordering feature, option HK. In combination with the option "electropolished", the wetted parts of the Varivent connection are made of 316L (1.4435).
- 5) Alternatively available with TempC diaphragm.

**PMP55: hygienic process connections with flush-mounted process isolating diaphragm**

**DRD DN50 (65 mm)**

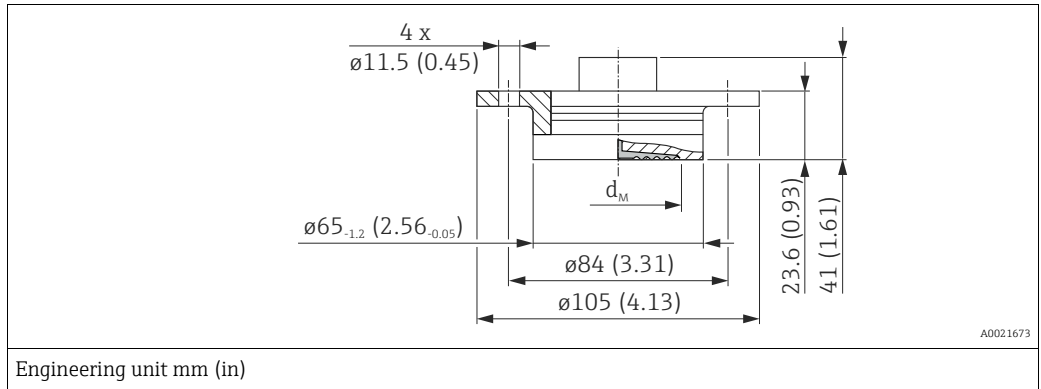

Material <sup>1)</sup>	Nominal pressure	Max. diaphragm diameter		Weight [kg (lbs)]	Option <sup>2)</sup>
		Standard d <sub>M</sub> [mm]	With TempC diaphragm d <sub>M</sub> [mm]		
AISI 316L	PN 25	50	48	0.75 (1.65)	TJ <sup>3)</sup>

- 1) Surface roughness of the surfaces in contact with the medium  $R_a \leq 0.76 \mu\text{m}$  (29.9  $\mu\text{in}$ ) as standard.
- 2) Product Configurator, "Process connection" ordering feature
- 3) Alternatively available with TempC diaphragm.

**SMS nozzles with coupling nut**

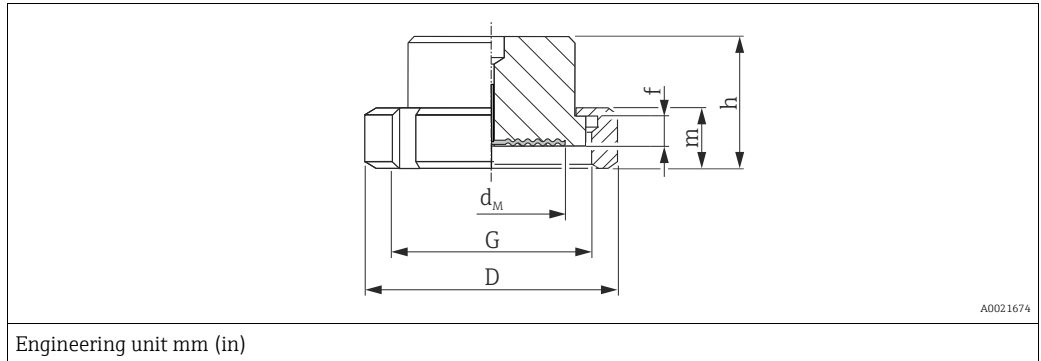

Material <sup>1)</sup>	Nominal diameter	Nominal pressure	Diameter D	Adapter height f	Thread G	Height m	Height h	Max. diaphragm diameter d <sub>M</sub>	Weight [kg (lbs)]	Approval	Option <sup>2)</sup>
	[in]	[bar]	[mm]	[mm]		[mm]	[mm]	[mm]	[kg (lbs)]		
AISI 316L	1	PN 25	54	3.5	Rd 40 - 1/6	20	42.5	24	0.25 (0.55)	EHEDG, 3A, ASME-BPE	T6J
	1 ½	PN 25	74	4	Rd 60 - 1/6	25	57	36	0.65 (1.43)		T7J <sup>3)</sup>
	2	PN 25	84	4	Rd 70 - 1/6	26	62	48	1.05 (2.32)		TXJ <sup>3)</sup>

- 1) Surface roughness of the surfaces in contact with the medium  $R_a \leq 0.76 \mu\text{m}$  (29.9  $\mu\text{in}$ ) as standard.
- 2) Product Configurator, "Process connection" ordering feature
- 3) Alternatively available with TempC diaphragm.

**APV-RJT nozzles with coupling nut**

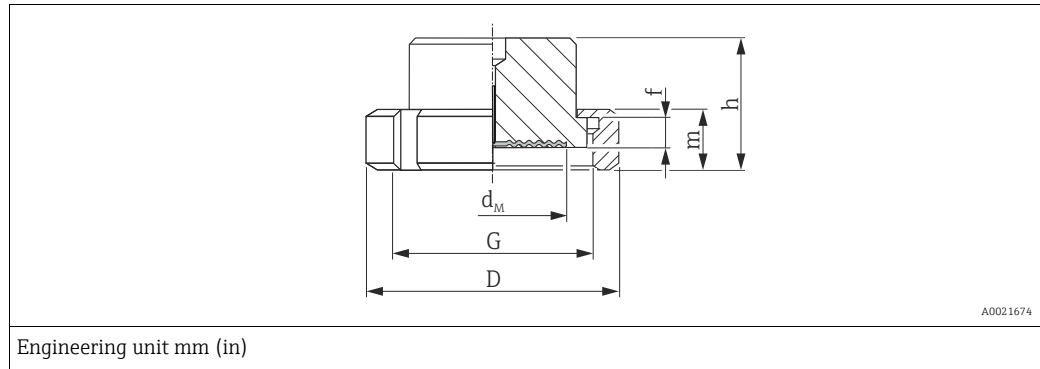

Material <sup>1)</sup>	Nominal diameter	Nominal pressure	Diameter	Adapter height	Thread	Height	Height	Max. diaphragm diameter	Weight	Option <sup>2)</sup>
		PN	D	f	G	m	h	d <sub>M</sub>		
	[in]	[bar]	[mm]	[mm]		[mm]	[mm]	[mm]	[kg (lbs)]	
AISI 316L	1	PN 40	77	6.5	1 13/16 - 1/8"	22	42.6	21	0.45 (0.99)	T0J
	1 ½	PN 40	72	6.4	2 5/16 - 1/8"	22	42.6	28	0.75 (1.65)	T1J
	2	PN 40	86	6.4	2 7/8 - 1/8"	22	42.6	38	1.2 (2.65)	T2J

- 1) Surface roughness of the surfaces in contact with the medium  $R_a \leq 0.8 \mu\text{m}$  (31.5  $\mu\text{in}$ ) as standard.
- 2) Product Configurator, "Process connection" ordering feature

**APV-ISS nozzles with coupling nut**

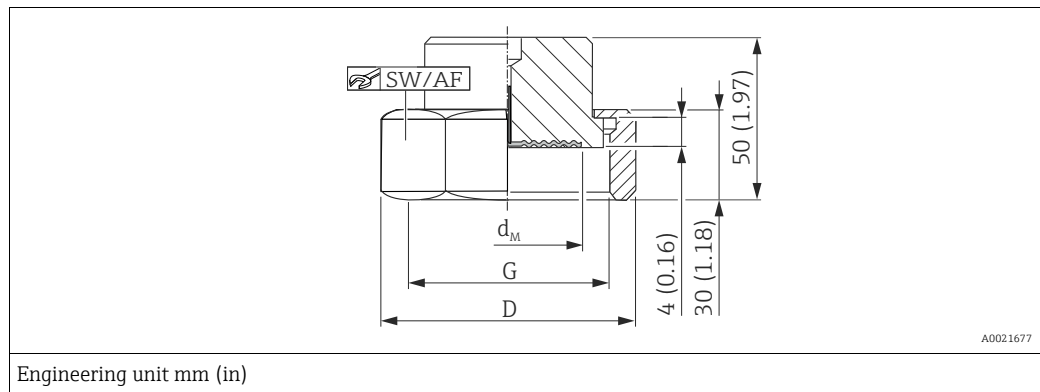

Material <sup>1)</sup>	Nominal diameter	Nominal pressure	Diameter	Thread	Across flats	Max. diaphragm diameter	Weight	Option <sup>2)</sup>
			D	G	AF	d <sub>M</sub>		
	[in]	[bar]	[mm]			[mm]	[kg (lbs)]	
AISI 316L	1	PN 40	54.1	1 ½" - 1/8"	46.8	24	0.4 (0.88)	T3J
	1 ½	PN 40	72	2" - 1/8"	62	34	0.6 (1.32)	T4J
	2	PN 40	89	2 ½" - 1/8"	77	45	1.1 (2.43)	T5J

- 1) Surface roughness of the surfaces in contact with the medium  $R_a \leq 0.8 \mu\text{m}$  (31.5  $\mu\text{in}$ ) as standard.
- 2) Product Configurator, "Process connection" ordering feature



**PMP55: hygienic process connections with flush-mounted process isolating diaphragm**

**Aseptic screwed union, nozzle, DIN 11864-1 Form A; pipe DIN 11866-A**

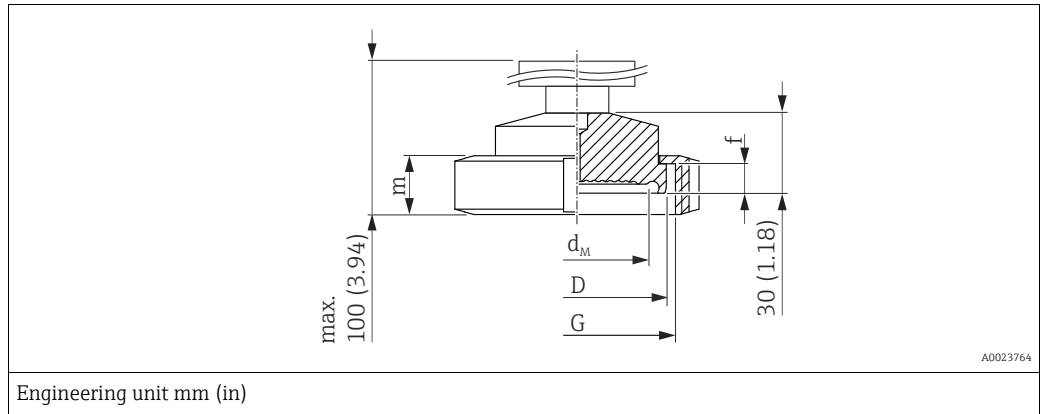

Material <sup>1)</sup>	Taper adapter				Slotted nut		Diaphragm seal		Approval	Option <sup>2)</sup>
	Nominal diameter	Nominal pressure	Diameter D	Adapter height f	Thread G	Height m	Max. diaphragm diameter d <sub>M</sub>	Weight Diaphragm seal		
			[mm]	[mm]		[mm]	[mm]	[kg (lbs)]		
AISI 316L	DN 40	PN 40	55	10	Rd 65 x 1/6"	21	36	0.63 (1.39)	EHEDG, 3A, ASME-BPE	NCJ
	DN 50	PN 25	67	11	Rd 78 x 1/6"	22	48	0.92 (2.03)	EHEDG, 3A, ASME-BPE	NDJ

- 1) Surface roughness of the surfaces in contact with the medium  $R_a \leq 0.8 \mu\text{m}$  (31.5  $\mu\text{in}$ ) as standard.
- 2) Product Configurator, "Process connection" ordering feature

**Aseptic flange connection, DIN 11864-2 Form A; pipe DIN 11866-1**

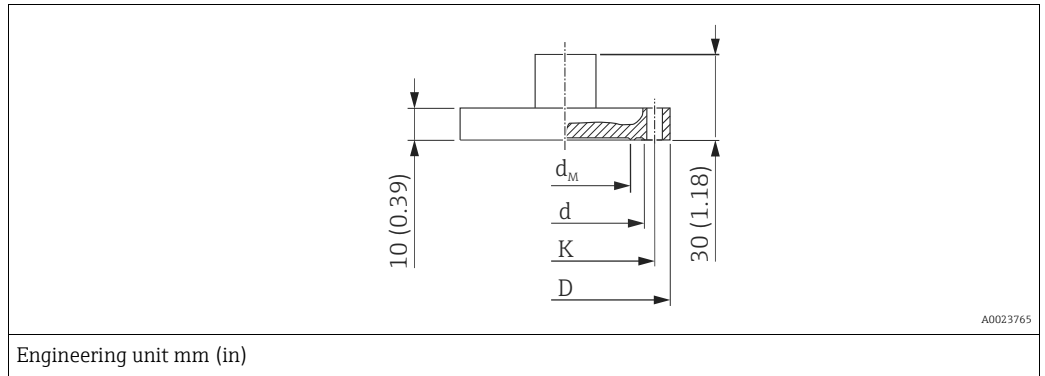

Material <sup>1)</sup>	Collar flange					Diaphragm seal		Approval	Option <sup>2)</sup>
	Nominal diameter	Nominal pressure	Hole circle diameter K	Seal diameter d	Outer diameter D	Max. diaphragm diameter d <sub>M</sub>	Weight Diaphragm seal		
			[mm]	[mm]	[mm]	[mm]	[kg]		
AISI 316L	DN 32	PN 16	59	47.7	76	25	1.5 (3.31)	EHEDG, 3A, ASME-BPE	NFJ
	DN 40		65	53.7	82	35	1.7 (3.75)	EHEDG, 3A, ASME-BPE	NXJ
	DN 50		77	65.7	94	45	2.2 (4.85)	EHEDG, 3A, ASME-BPE	NZJ

- 1) Surface roughness of the surfaces in contact with the medium  $R_a \leq 0.8 \mu\text{m}$  (31.5  $\mu\text{in}$ ) as standard.
- 2) Product Configurator, "Process connection" ordering feature

## Taper adapter with coupling nut, DIN 11851

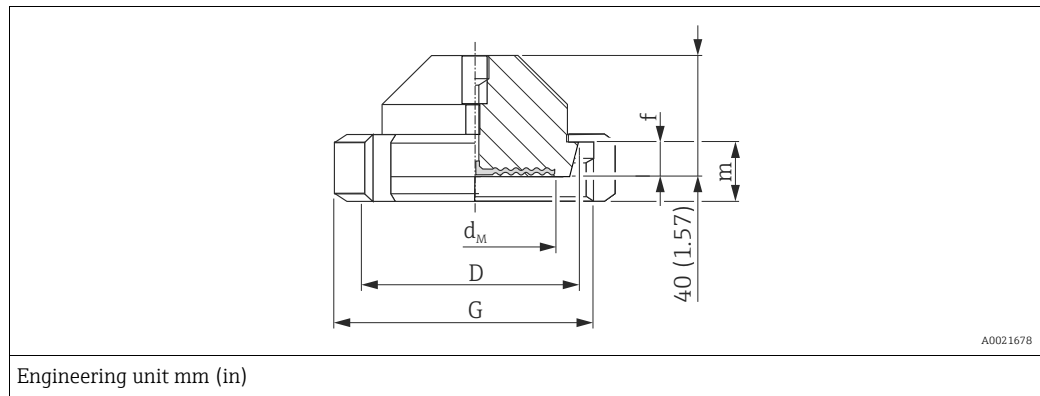

Material <sup>1)</sup>	Taper adapter				Slotted nut		Diaphragm seal			Approval	Option <sup>2)</sup>
	Nominal diameter	Nominal pressure	D	Adapter height f	Thread G	Height m	Max. diaphragm diameter		Weight		
							Standard	With TempC diaphragm			
			[mm]	[mm]		[mm]	d <sub>M</sub> [mm]	d <sub>M</sub> [mm]	[kg (lbs)]		
AISI 316L	DN 32	PN 40	50	10	Rd 58 x 1/6"	21	32	28	0.45 (0.99)	EHEDG, 3A, ASME-BPE	MIJ
	DN 40	PN 40	56	10	Rd 65 x 1/6"	21	38	36	0.45 (0.99)	EHEDG, 3A, ASME-BPE	MZJ <sup>3)</sup>
	DN 50	PN 25	68.5	11	Rd 78 x 1/6"	19	52	48	1.1 (2.43)	EHEDG, 3A, ASME-BPE	MRJ <sup>3)</sup>
	DN 65	PN 25	86	12	Rd 95 x 1/6"	21	66	61	2.0 (4.41)	EHEDG, 3A, ASME-BPE	MSJ <sup>3)</sup>
	DN 80	PN 25	100	12	Rd 110 x 1/4"	26	81	61	2.55 (5.62)	EHEDG, 3A, ASME-BPE	MTJ <sup>3)</sup>

1) Surface roughness of the surfaces in contact with the medium  $R_a \leq 0.76 \mu\text{m}$  (29.9  $\mu\text{in}$ ) as standard.

2) Product Configurator, "Process connection" ordering feature

3) Alternatively available with TempC diaphragm.

**NEUMO BioControl**

Process temperature range: -10 °C to +200 °C (14 °F to +392 °F)

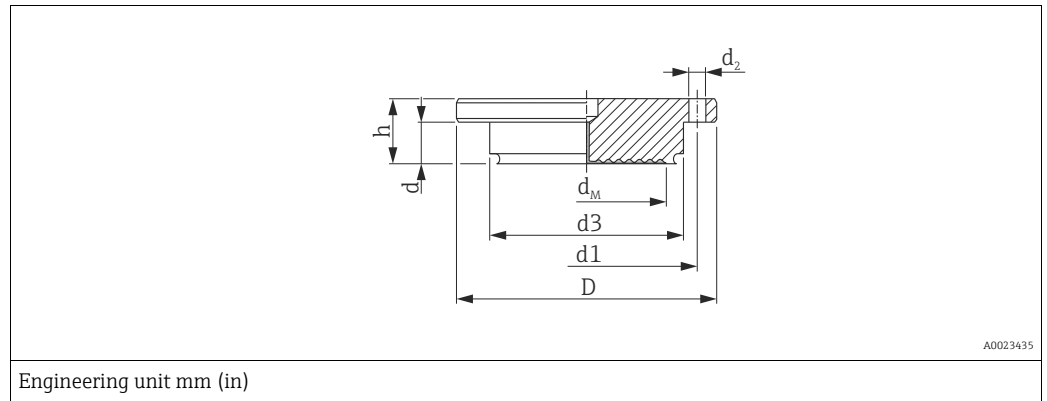

Material <sup>1)</sup>	NEUMO BioControl								Diaphragm seal			Approval	Option <sup>2)</sup>
	Nominal diameter	Nominal pressure	D	d	d <sub>1</sub>	d <sub>2</sub>	d <sub>3</sub>	Height h	Max. diaphragm diameter		Weight		
									Standard	With TempC diaphragm			
			[mm]	[mm]	[mm]	[mm]	[mm]	[mm]	d <sub>M</sub> [mm]	d <sub>M</sub> [mm]	[kg]		
AISI 316L	DN 50	PN 16	90	17	70	4 x Ø 9	50	27	40	41	1.1 (2.43)	3A, ASME-BPE	S4J <sup>3)</sup>
	DN 80	PN 16	140	25	115	4 x Ø 11	87.4	37	-	61	2.6 (5.73)	EHEDG, 3A, ASME-BPE	S6J <sup>4)</sup>

- 1) Surface roughness of the surfaces in contact with the medium  $R_a \leq 0.76 \mu\text{m}$  (29.9  $\mu\text{in}$ ) as standard.
- 2) Product Configurator, "Process connection" ordering feature
- 3) Alternatively available with TempC diaphragm.
- 4) With TempC diaphragm

**Universal adapter**

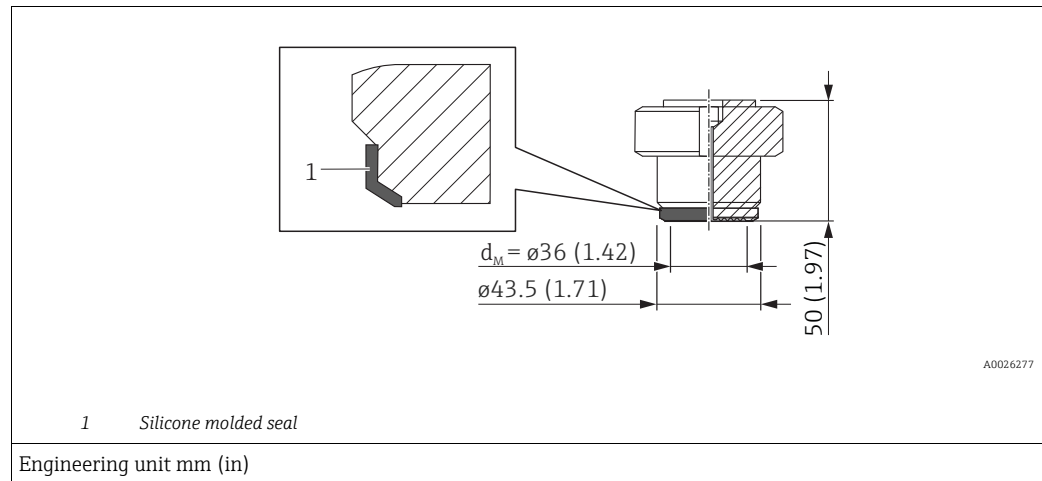

Designation	Nominal pressure	Material <sup>1) 2)</sup>	Weight [kg/lbs]	Approval <sup>3)</sup>	Option <sup>4)</sup>
Universal adapter with silicone molded seal (spare part no.: 52023572) FDA 21CFR177.2600/USP Class VI	PN 10	AISI 316L (1.4435)	0.8 (1.76)	EHEDG, 3A, ASME-BPE	UPJ <sup>5)</sup>

- 1) The roughness of the surface in contact with the medium is  $R_a$  0.76  $\mu\text{m}$  (30  $\mu\text{in}$ ). Version optionally in conformity with ASME-BPE for use in biochemical processes, wetted surfaces  $R_a$  0.38  $\mu\text{m}$  (15  $\mu\text{in}$ ), electropolished; ordering information: Product Configurator, "Service" ordering feature, option "HK".
- 2) Endress+Hauser supplies these slotted nuts in stainless steel AISI 304 (1.4301) or in AISI 304L (1.4307).
- 3) EHEDG or 3A approval only with approved process connection.
- 4) Product Configurator, "Process connection" ordering feature
- 5) Alternatively available with TempC diaphragm.

**PMP55: process connections with flush-mounted process isolating diaphragm**

**EN/DIN flanges, connection dimensions as per EN 1092-1/DIN 2527 and DIN 2501-1**

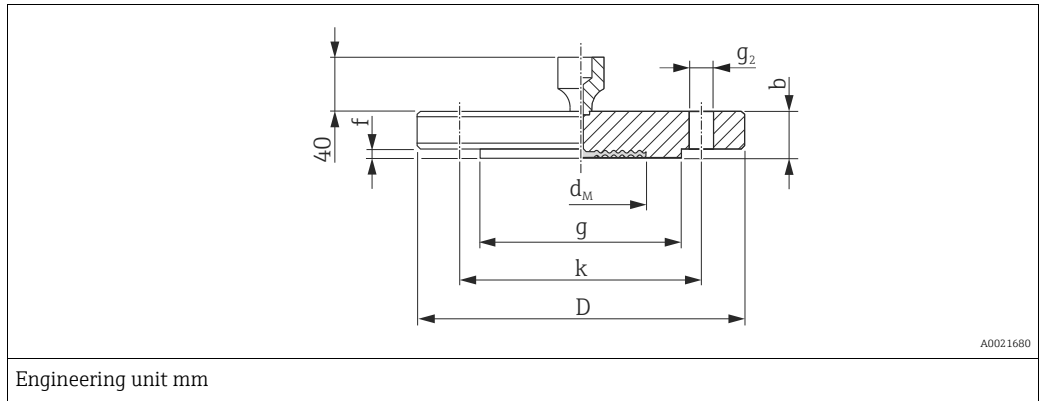

Flanges <sup>1) 2)</sup>							Boltholes			Diaphragm seal		Option <sup>3)</sup>	
Material	Nominal diameter	Nominal pressure	Shape <sup>4)</sup>	D	Thickness b	Raised face		Quantity	g <sub>2</sub>	Hole circle k	Max. diaphragm diameter d <sub>M</sub>		Weight
						g	f						
		PN		[mm]	[mm]	[mm]			[mm]	[mm]	[mm]	[kg (lbs)]	
AISI 316L	DN 25	10-40	B1 (D)	115	18	68	3	4	14	85	32	2.1 (4.63)	CNJ
	DN 25	63-160	B2 (E)	140	24	68	2	4	18	100	28	2.5 (5.51)	QIJ
	DN 25	250	B2 (E)	150	28	68	2	4	22	105	28	3.7 (8.16)	QJJ
	DN 25	400	B2 (E)	180	38	68	2	4	26	130	28	7.0 (15.44)	QSJ
	DN 32	10-40	B1 (D)	140	18	77	2,6	4	18	100	34	1.9 (4.19)	CPJ
	DN 40	10-40	B1 (D)	150	18	87	2,6	4	18	110	48	2.2 (4.85)	CQJ
	DN 50	10-40	B1 (D)	165	20	102	3	4	18	125	59	3.0 (6.62)	CXJ
	DN 50	63	B2 (E)	180	26	102	3	4	22	135	59	4.6 (10.14)	PDJ
	DN 50	100-160	B2 (E)	195	30	102	3	4	26	145	59	6.2 (13.67)	QOJ
	DN 50	250	B2 (E)	200	38	102	3	8	26	150	59	7.7 (16.98)	QMJ
	DN 50	400	B2 (E)	235	52	102	3	8	30	180	59	14.7 (32.41)	QVJ
	DN 80	10-40	B1 (D)	200	24	138	3,5	8	18	160	89	5.3 (11.69)	CZJ
	DN 80	100	B2 (E)	230	32	138	4	8	24	180	89	8.9 (19.62)	PPJ
	DN 100	100	B2 (E)	265	36	175	5	8	30	210	89	13.7 (30.21)	PQJ

- 1) The roughness of the surface in contact with the media, including the raised face of the flanges (all standards) made of Alloy C276, Monel, Tantalum, Rhodium>Gold or PTFE is Ra <0.8 µm (31.5 µin). Lower surface roughness on request.
- 2) The flange raised face is made of the same material as the process isolating diaphragm.
- 3) Product Configurator, "Process connection" ordering feature
- 4) Designation as per DIN 2527 in brackets

**EN/DIN flanges with barrel (extended diaphragm seal), connection dimensions as per EN 1092-1/DIN 2527 and DIN 2501-1**

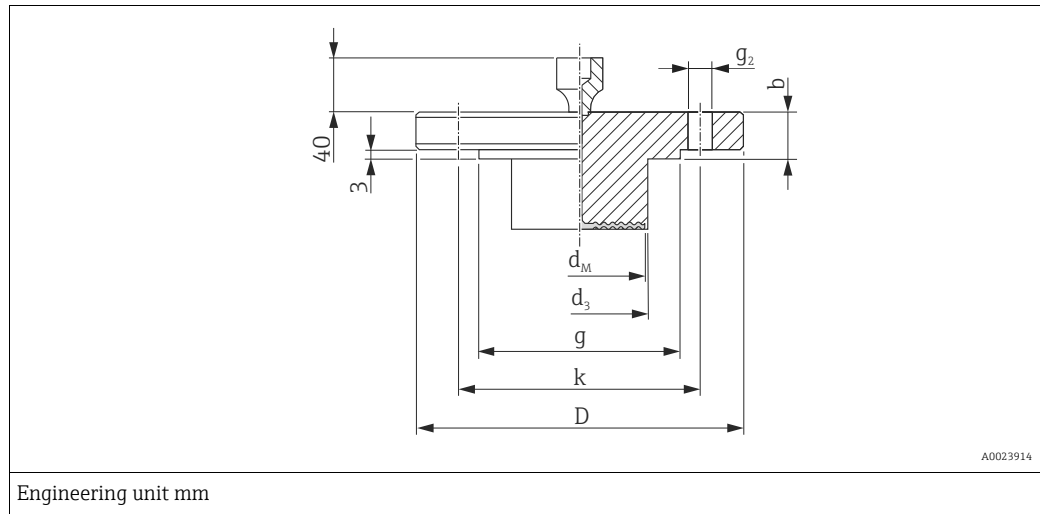

Flanges <sup>1)</sup>							Boltholes			Diaphragm seal		Option <sup>2)</sup>
Material	Nominal diameter	Nominal pressure	Shape <sup>3)</sup>	D	Thickness b	Raised face g	Quantity	g <sub>2</sub>	Hole circle k	Max. diaphragm diameter d <sub>M</sub>	Weight	
				[mm]	[mm]	[mm]		[mm]	[mm]	[mm]	[kg (lbs)]	
AISI 316L	DN 50	PN 10-40	B1 (D)	165	20	102	4	18	125	47	<sup>4)</sup>	FDJ <sup>4)</sup>
	DN 80	PN 10-40	B1 (D)	200	24	138	8	18	160	72	<sup>4)</sup>	FEJ <sup>4)</sup>

- 1) For process isolating diaphragms made of Alloy C276, Monel oder tantalum, the raised face of the flange and the Barrel made of 316L.
- 2) Product Configurator, "Process connection" ordering feature
- 3) Designation as per DIN 2527 in brackets
- 4) Available with 50 mm (1.97 in), 100 mm (3.94 in) or 200 mm (7.87 in) barrel (extended diaphragm seal), for barrel (extended diaphragm seal) diameter and weight see the following table

Option <sup>1)</sup>	Nominal diameter	Nominal pressure	Barrel (extended diaphragm seal) length (L)	Barrel (extended diaphragm seal) diameter d <sub>3</sub>	Weight
			[mm]	[mm]	[kg (lbs)]
FDJ	DN 50	PN 10-40	50 / 100 / 200	48.3	3.2 (7.1) / 3.8 (8.4) / 4.4 (9.7)
FEJ	DN 80	PN 10-40	50 / 100 / 200	76	6.2 (13.7) / 6.7 (14.8) / 7.8 (17.2)

- 1) Product Configurator, "Process connection" ordering feature

**PMP55: process connections with flush-mounted process isolating diaphragm**

**ASME flanges, connection dimensions as per ASME B 16.5, raised face RF**

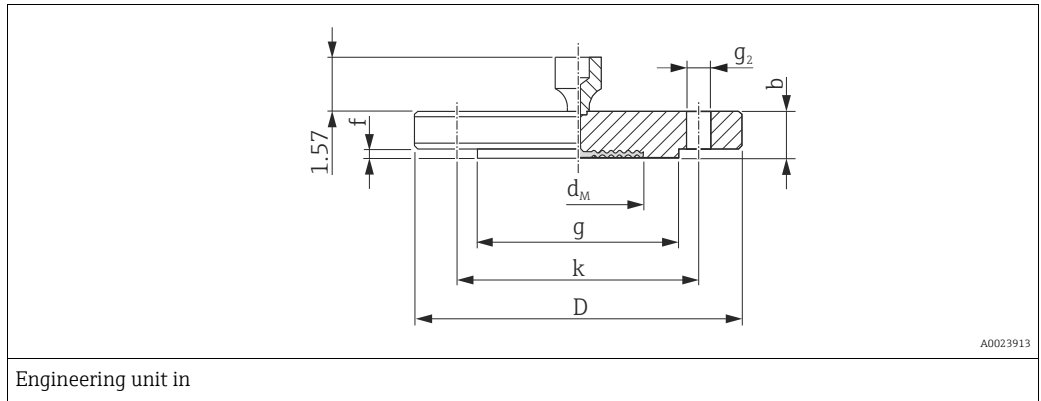

Material <sup>1)</sup>	Flange <sup>2) 3)</sup>						Boltholes			Diaphragm seal		Approval <sup>4)</sup>	Option <sup>5)</sup>
	Nominal diameter	Class	D	b	Raised face		Quantity	g <sub>2</sub>	Hole circle	Max. diaphragm diameter	Weight		
					g	f							
[in]	[lb./sq.in]	[in]	[in]	[in]	[in]	[in]	[in]	[in]	[in]	[in]	[kg (lbs)]		
AISI 316/ 316L	1	150	4.25	0.56	2	0.08	4	0.62	3.12	1.26	1.2 (2.65)	CRN	ACJ
	1	300	4.88	0.69	2	0.08	4	0.75	3.5	1.26	1.3 (2.87)	CRN	ANJ
	1	400/600	4.88	0.69	2	0.25	4	0.75	3.5	1.26	1.4 (3.09)	CRN	A0J
	1	900/1500	5.88	1.12	2	0.25	4	1	4	1.26	3.2 (7.06)	CRN	A2J
	1	2500	6.25	1.38	2	0.25	4	1	4.25	1.26	4.6 (10.14)	CRN	A4J
	1 ½	150	5	0.69	2.88	0.06	4	0.62	3.88	1.89	1.5 (3.31)	CRN	AEJ
	1 ½	300	6.12	0.81	2.88	0.06	4	0.88	4.5	1.89	2.6 (5.73)	CRN	AQJ
	2	150	6	0.75	3.62	0.06	4	0.75	4.75	2.32	2.2 (4.85)	CRN	AFJ
	2	300	6.5	0.88	3.62	0.06	8	0.75	5	2.32	3.4 (7.5)	CRN	ARJ
	2	400/600	6.5	1	3.62	0.25	8	0.75	5	2.32	4.3 (9.48)	CRN	A1J
	2	900/1500	8.5	1.5	3.62	0.25	8	1	6.5	2.32	10.3 (22.71)	CRN	A3J
	2	2500	9.25	2	3.62	0.25	8	1.12	6.75	2.32	15.8 (34.84)	CRN	A5J
	3	150	7.5	0.94	5	0.06	4	0.75	6	3.50	5.1 (11.25)	CRN	AGJ
	3	300	8.25	1.12	5	0.06	8	0.75	6	3.50	7.0 (15.44)	CRN	ASJ
	4	150	9	0.94	6.19	0.06	8	0.75	7.5	3.50	7.2 (15.88)	CRN	AHJ
	4	300	10	1.25	6.19	0.06	8	0.88	7.88	3.50	11.7 (25.8)	CRN	ATJ

- 1) Combination of AISI 316 for required pressure resistance and AISI 316L for required chemical resistance (dual rated)
- 2) The roughness of the surface in contact with the media, including the raised face of the flanges (all standards) made of Alloy C276, Monel, Tantalum, Rhodium>Gold or PTFE is Ra <0.8 μm (31.5 μin). Lower surface roughness on request.
- 3) The flange raised face is made of the same material as the process isolating diaphragm.
- 4) CSA approval: Product Configurator, "Approval" ordering feature
- 5) Product Configurator, "Process connection" ordering feature

**ASME flanges with barrel (extended diaphragm seal), connection dimensions as per ASME B 16.5, raised face RF**

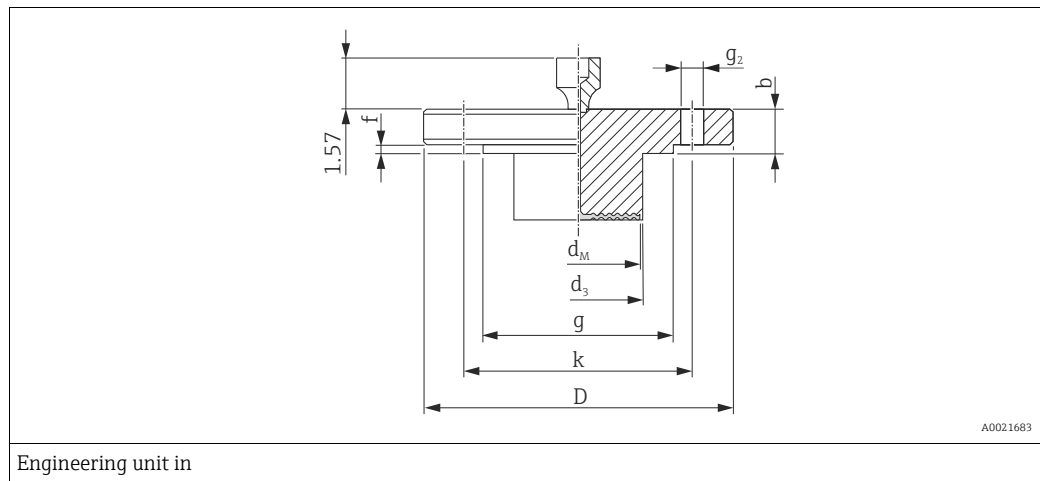

Flange <sup>1)</sup>							Boltholes			Diaphragm seal		Approval <sup>2)</sup>	Option <sup>3)</sup>
Material <sup>4)</sup>	Nominal diameter	Class	D	Thickness b	Raised face g   f		Quantity	g <sub>2</sub>	Hole circle k	Max. diaphragm diameter d <sub>M</sub>	Weight		
	[in]	[lb./sq.in]	[in]	[in]	[in]	[in]		[in]	[in]	[in]	[kg (lbs)]		
AISI 316/ 316L	2	150	6	0.75	3.62	0.06	4	0.75	4.75	1.85	<sup>5)</sup>	CRN	FMJ <sup>5)</sup>
	3	150	7.5	0.94	5	0.06	4	0.75	6	2.83	<sup>5)</sup>	CRN	FNJ <sup>5)</sup>
	3	300	8.25	1.12	5	0.06	8	0.88	6.62	2.83	<sup>5)</sup>	CRN	FWJ <sup>5)</sup>
	4	150	9	0.94	6.19	0.06	8	0.75	7.5	3.50	<sup>5)</sup>	CRN	FOJ <sup>5)</sup>
	4	300	10	1.25	6.19	0.06	8	0.88	7.88	3.50	<sup>5)</sup>	CRN	FXJ <sup>5)</sup>

- 1) For process isolating diaphragms made of Alloy C276, Monel oder tantalum, the raised face of the flange and the Barrel made of 316L.
- 2) CSA approval: Product Configurator, "Approval" ordering feature
- 3) Product Configurator, "Process connection" ordering feature
- 4) Combination of AISI 316 for required pressure resistance and AISI 316L for required chemical resistance (dual rated)
- 5) Available with 2", 4", 6" and 8" barrel (extended diaphragm seal), for barrel (extended diaphragm seal) diameter and weight see the following table

Option <sup>1)</sup>	Nominal diameter	Class	Barrel (extended diaphragm seal) length (L)	Barrel (extended diaphragm seal) diameter d <sub>3</sub>	Weight
	[in]	[lb./sq.in]	in (mm)	in (mm)	[kg (lbs)]
FMJ	2	150	2 (50.8) / 4 (101.6) / 6 (152.4) / 8 (203.2)	1.9 (48.3)	3.0 (6.6) / 3.4 (7.5) / 3.9 (8.6) / 4.4 (9.7)
FNJ	3	150	2 (50.8) / 4 (101.6) / 6 (152.4) / 8 (203.2)	2.99 (76)	6.0 (13.2) / 6.6 (14.5) / 7.1 (15.7) / 7.8 (17.2)
FWJ	3	300	2 (50.8) / 4 (101.6) / 6 (152.4) / 8 (203.2)	2.99 (76)	7.9 (17.4) / 8.5 (18.7) / 9.0 (19.9) / 9.6 (21.2)
FOJ	4	150	2 (50.8) / 4 (101.6) / 6 (152.4) / 8 (203.2)	3.7 (94)	8.6 (19) / 9.9 (21.8) / 11.2 (24.7) / 12.4 (27.3)
FXJ	4	300	2 (50.8) / 4 (101.6) / 6 (152.4) / 8 (203.2)	3.7 (94)	13.1 (28.9) / 14.4 (31.6) / 15.7 (34.6) / 16.9 (37.3)

- 1) Product Configurator, "Process connection" ordering feature



JIS flanges, connection dimensions as per JIS B 2220 BL, raised face RF

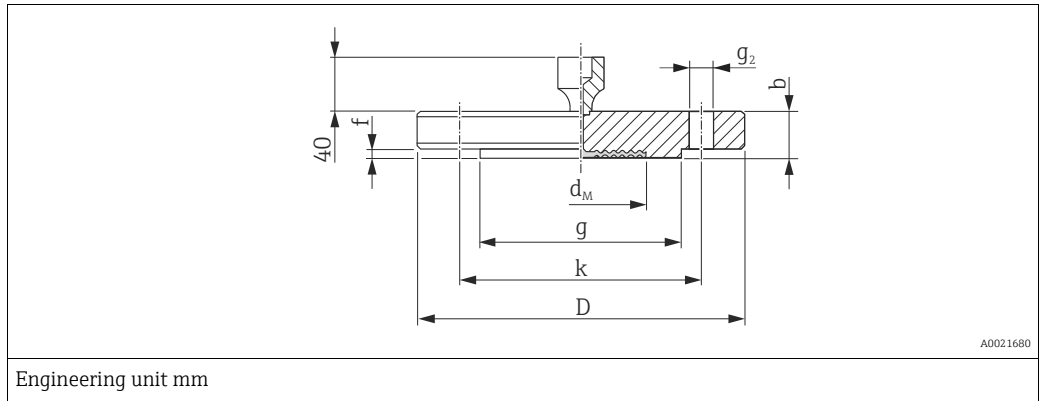

Flange <sup>1) 2)</sup>							Boltholes			Diaphragm seal		Option <sup>3)</sup>
Material	Nominal diameter	Nominal pressure	D	Thickness b	Diameter of raised face g	Height of raised face f	Quantity	g <sub>2</sub>	Hole circle k	Max. diaphragm diameter d <sub>M</sub>	Weight	
			[mm]	[mm]	[mm]	[mm]		[mm]	[mm]	[mm]	[kg (lbs)]	
AISI 316L	25 A	10 K	125	14	67	1	4	19	90	32	1.5 (3.31)	KCJ
	40 A	10 K	140	16	81	2	4	19	105	48	2.0 (4.41)	KEJ
	50 A	10 K	155	16	96	2	4	19	120	59	2.3 (5.07)	KFJ
	80 A	10 K	185	18	127	2	8	19	150	89	3.3 (7.28)	KGJ
	100 A	10 K	210	18	151	2	8	19	175	89	4.4 (9.7)	KHJ

- 1) The roughness of the surface in contact with the media, including the raised face of the flanges (all standards) made of Alloy C276, Monel, Tantalum, Rhodium>Gold or PTFE is Ra <0.8 μm (31.5 μin). Lower surface roughness on request.
- 2) The flange raised face is made of the same material as the process isolating diaphragm.
- 3) Product Configurator, "Process connection" ordering feature

PMP55 process connections Welded separators

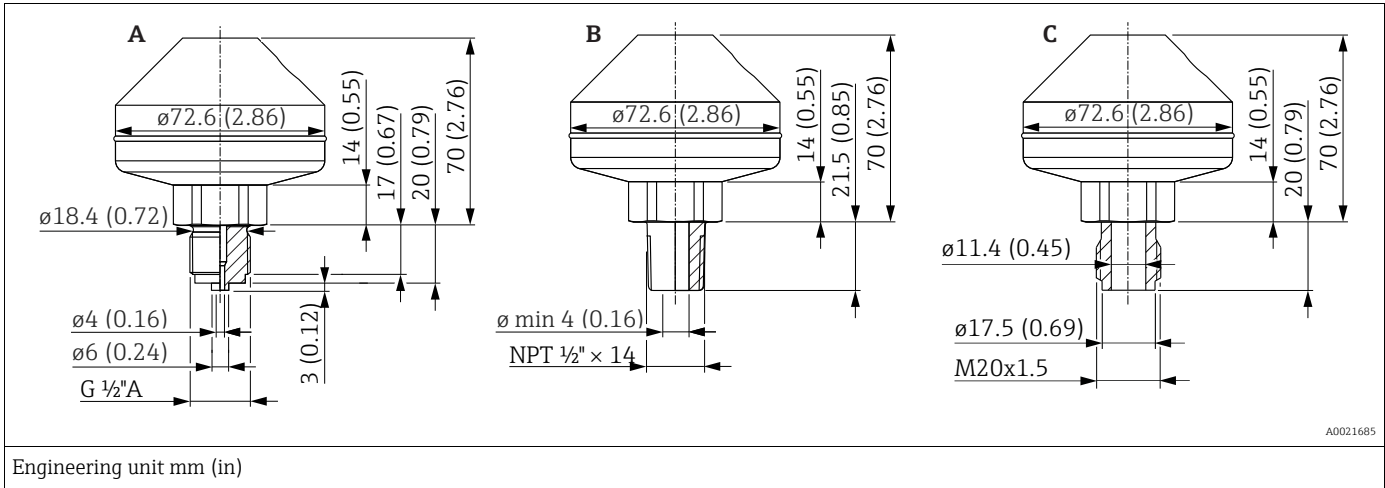

Position	Description	Material	Measuring range	Nominal pressure	Approval	Weight	Option <sup>1)</sup>
			[bar (psi)]			[kg (lbs)]	
A	Welded, ISO 228 G 1/2 A EN837	AISI 316L	≤ 160 (2320)	PN 160	-	1.43 (3.15)	UBJ
B	Welded, ANSI 1/2 MNPT				CRN <sup>2)</sup>		UCJ
C	Welded, thread DIN13 M20x1.5				-		UFJ

- 1) Product Configurator, order code for "Process connection"
- 2) CSA approval: Product Configurator, order code for "Approval"

Threaded separators

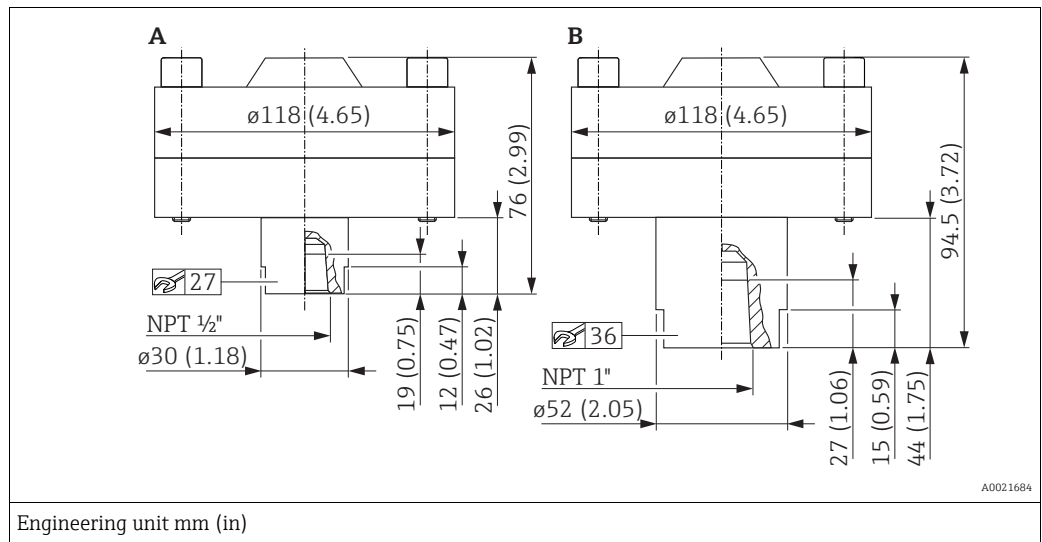

Position	Description	Material	Measuring range	Nominal pressure	Weight	Option <sup>1)</sup>
			[bar (psi)]		[kg (lbs)]	
A	Threaded, 1/2" NPT with FKM Viton seal -20 to +200 °C (-4 to +392 °F)	AISI 316L screws made of A4	≤ 250 (3625)	PN 250	4.75 (10.47)	UGJ
B	Threaded, 1" NPT with FKM Viton seal -20 to +200 °C (-4 to +392 °F)				5.0 (11.03)	UHJ

- 1) Product Configurator, order code for "Process connection"

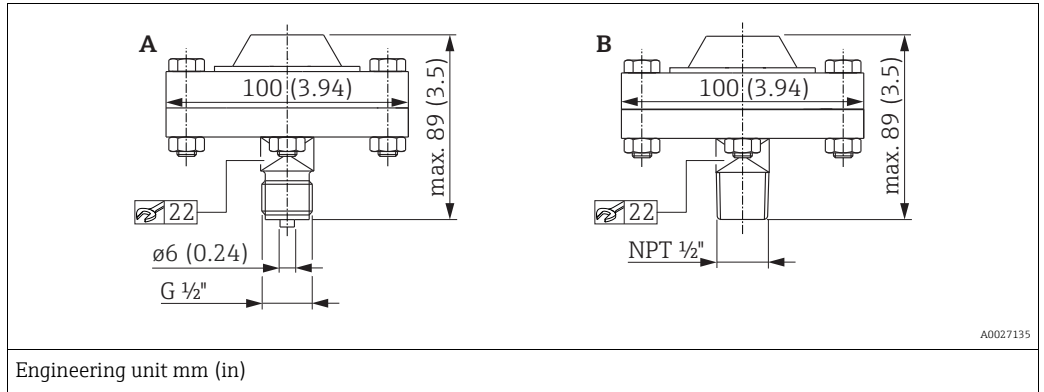

Position	Description	Material	Measuring range	Nominal pressure	Weight	Option <sup>1)</sup>
			[bar (psi)]		[kg (lbs)]	
A	Threaded, ISO 228 G 1/2 A EN837 with PTFE seal -40 to +260 °C (-40 to +500 °F)	AISI 316L, screws made of A4	≤ 40 (580)	PN 40	1.43 (3.15)	UDJ <sup>2)</sup>
B	Threaded, ANSI 1/2 MNPT with PTFE seal -40 to +260 °C (-40 to +500 °F)					UEJ <sup>2)</sup>

- 1) Product Configurator, order code for "Process connection"
- 2) In combination with silicone oil, inert oil and plant oil.

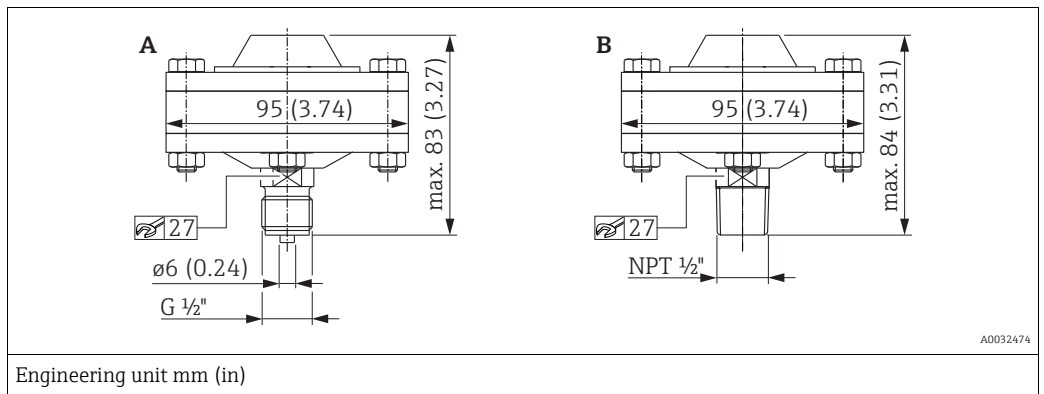

Position	Description	Material	Measuring range	Nominal pressure	Weight	Option <sup>1)</sup>
			[bar (psi)]		[kg (lbs)]	
A	Threaded, ISO 228 G 1/2 A EN837 with metal seal (silver-plated) -60 to +400 °C (-76 to +752 °F)	AISI 316L, screws made of A4	≤ 40 (580)	PN 40	1.43 (3.15)	UDJ <sup>2)</sup>
B	Threaded, ANSI 1/2 MNPT with metal seal (silverplated) -60 to +400 °C (-76 to +752 °F)					UEJ <sup>2)</sup>

- 1) Product Configurator, order code for "Process connection"
- 2) In combination with high-temperature oil.

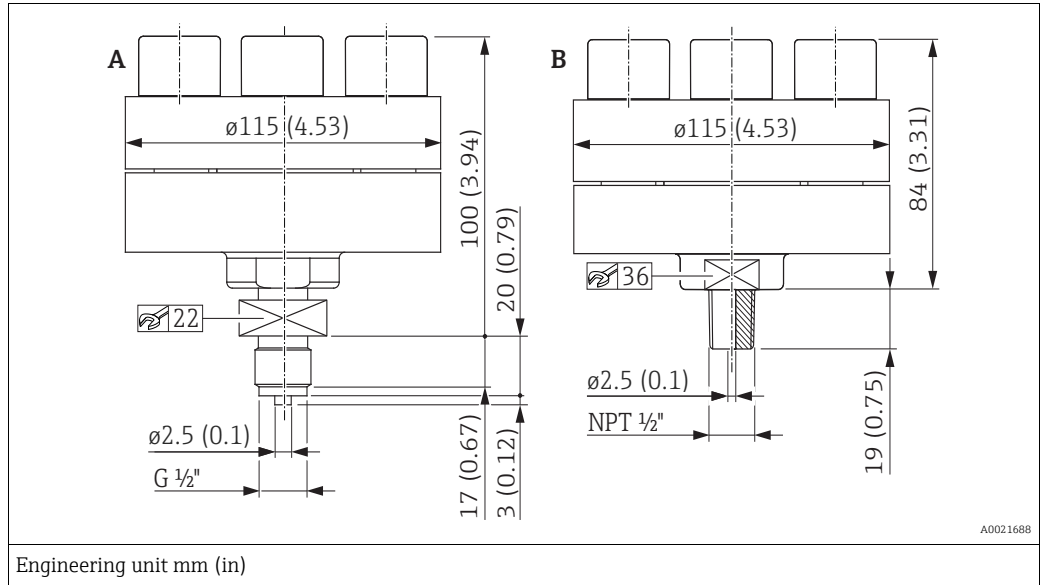

Position	Description	Material	Measuring range	Nominal pressure <sup>1)</sup>	Weight	Option <sup>2)</sup>
			[bar (psi)]		[kg (lbs)]	
A	Threaded, ISO 228 G ½ A EN837, with integrated seal lip -60 to +400 °C (-76 to +752 °F)	AISI 316L, screws made of A4	> 40 (580)	PN 400	4.75 (10.47)	UDJ
B	Threaded, ANSI ½ MNPT, with integrated seal lip -60 to +400 °C (-76 to +752 °F)					UEJ

1) This separator is assembled prior to delivery and must not be disassembled!

2) Product Configurator, order code for "Process connection"

Wall and pipe mounting with mounting bracket

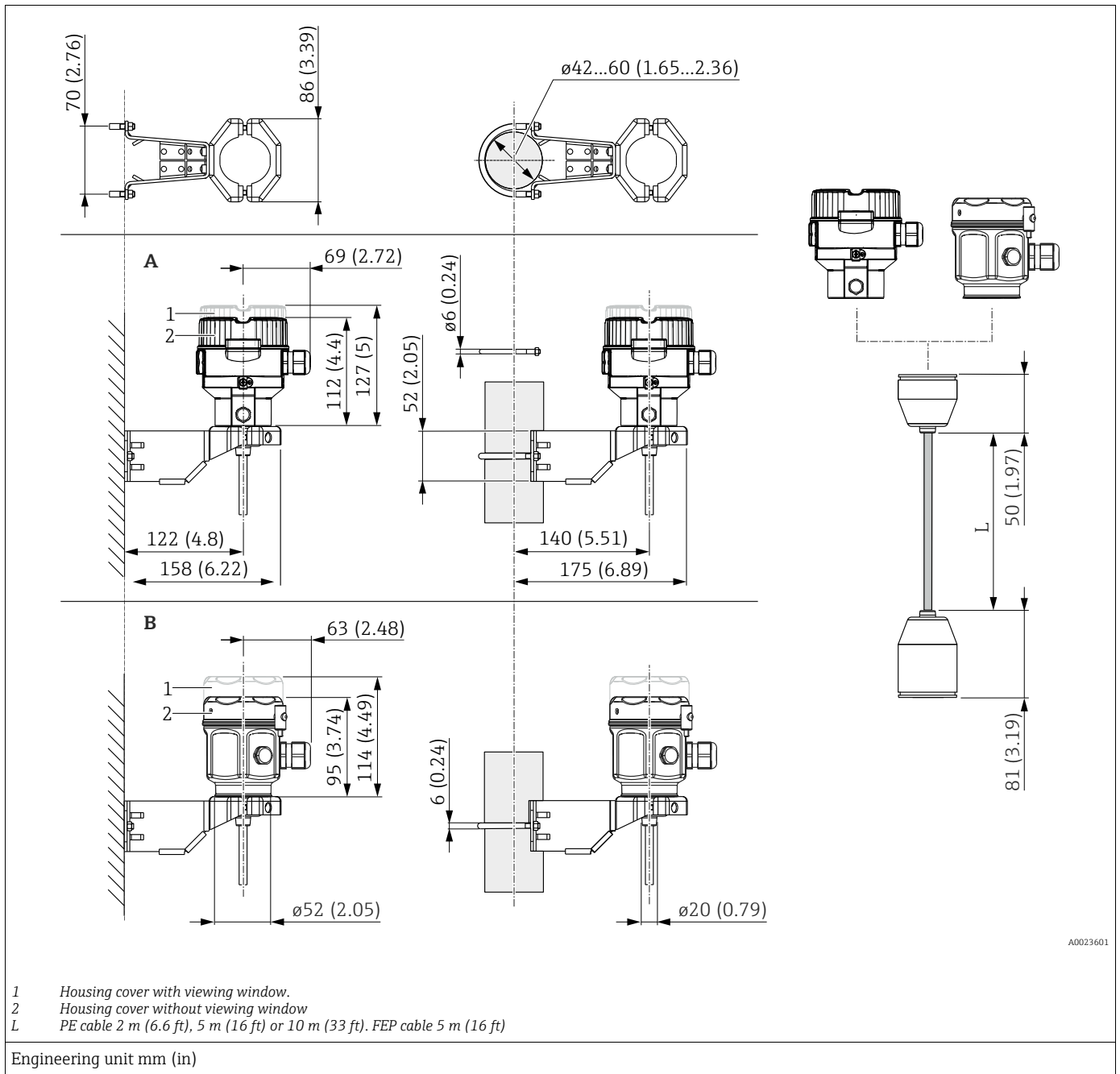

A0023601

Item	Designation	Weight		Option <sup>1)</sup>
		Housing (F31 or F15)	Mounting bracket	
A	Dimensions with F31 housing	→ 45 ff	0.5 kg (1.10)	U
B	Dimensions with F15 housing			

1) Product Configurator, "Separate housing" ordering feature

Also available for order as a separate accessory: part number 71102216

**Reduction in installation height**

If the separate housing is used, the mounting height of the process connection is reduced compared to the dimensions of the standard version.

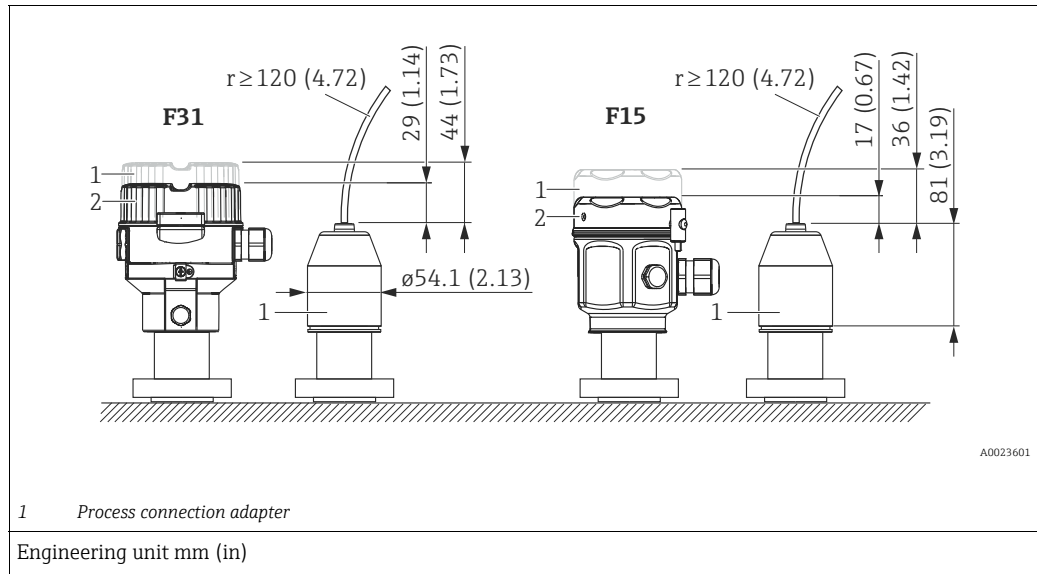

**Weight**

Component part	Weight
Housing	See "Housing" section
Process connection	See "Process connections" section
Capillary with armoring made of AISI 316L (1.4404)	0.16 kg/m (0.35 lb/m) + 0.2 kg (0.44 lb) (weight per capillary line)
Capillary with armoring made of AISI 316L (PVC)	0.21 kg/m (0.46 lb/m) + 0.2 kg (0.44 lb) (weight per capillary line)
Capillary with armoring made of AISI 316L (PTFE)	0.29 kg/m (0.64 lb/m) + 0.2 kg (0.44 lb) (weight per capillary line)

**Materials not in contact with process**      **F31 housing**

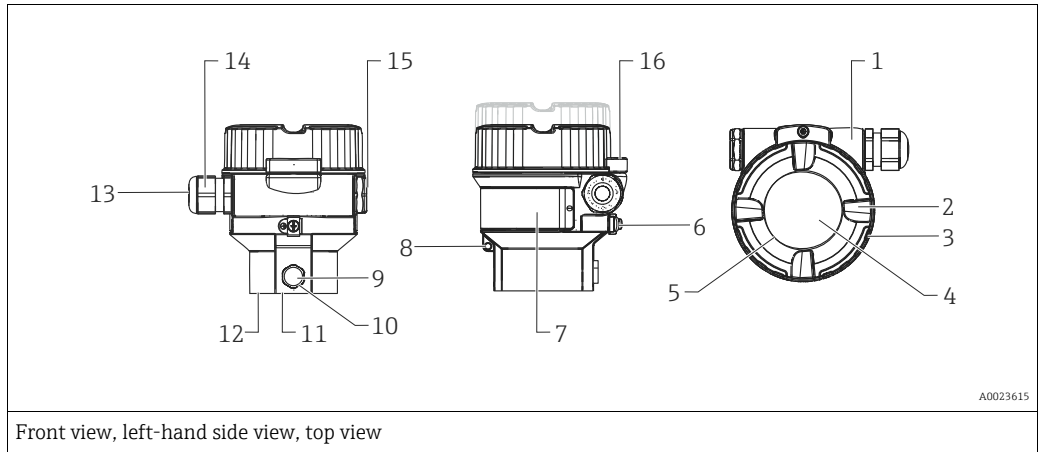

Front view, left-hand side view, top view

Item number	Component part	Material
1	F31 housing, RAL 5012 (blue)	Die-cast aluminum with protective powder-coating on polyester base
2	Cover, RAL 7035 (gray)	Die-cast aluminum with protective powder-coating on polyester base
3	Cover seal	EPDM
4	Sight glass	Mineral glass
5	Sight glass seal	Silicone (VMQ)
6	External ground terminal	AISI 304 (1.4301)
7	Nameplates	Plastic film
8	Attachement for tie-on label	AISI 304 (1.4301)/ AISI 316 (1.4401)
9	Pressure compensation filter	AISI 316L (1.4404) and PBT-FR
10	Pressure compensation filter, O-ring	VMQ or EPDM
11	Sealing ring	EPDM
12	Snap ring	PC Plastic
13	Seal of cable gland and blind plug	EPDM/NBR
14	Cable gland	Polyamide (PA), for dust ignition-proof: CuZn nickel-plated
15	Blind plug	PBT-GF30 FR for dust ignition-proof, Ex d, FM XP and CSA XP: AISI 316L (1.4435)
16	Cover clamp	Clamp AISI 316L (1.4435), screw A4

F15 housing

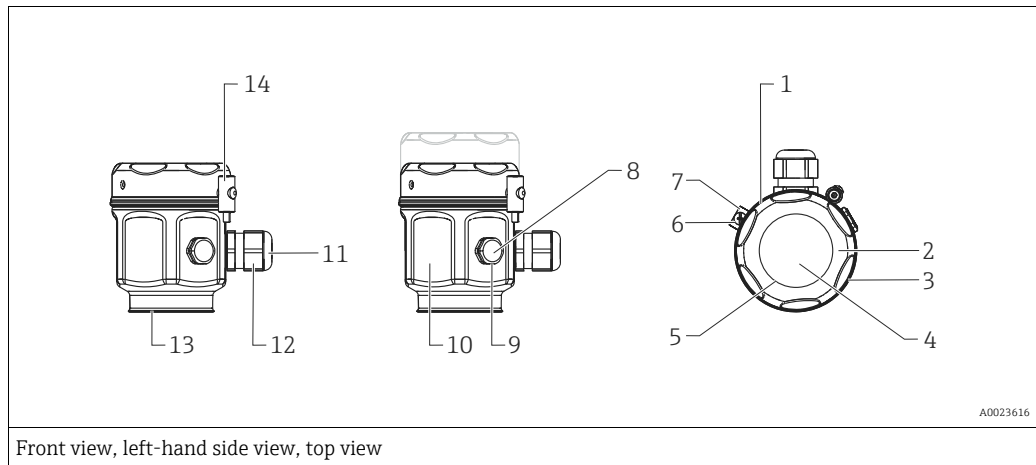

Front view, left-hand side view, top view

Item number	Component part	Material
1	F15 housing	AISI 316L (1.4404)
2	Cover	
3	Cover seal	Silicone with PTFE coating
4	Sight glass for non-hazardous area, ATEX Ex ia, NEPSI Zone 0/1 Ex ia, IECEx Zone 0/1 Ex ia, FM NI, FM IS, CSA IS	Polycarbonate (PC)
4	Sight glass for ATEX 1/2 D, ATEX 1/3 D, ATEX 1 GD, ATEX 1/2 GD, ATEX 3 G, FM DIP, CSA dust ignition-proof	Mineral glass
5	Sight glass seal	Silicone (VMQ)
6	External ground terminal	AISI 304 (1.4301)
7	Attachement for tie-on label	AISI 304 (1.4301)/ AISI 316 (1.4401)
8	Pressure compensation filter	AISI 316L (1.4404) and PBT-FR
9	Pressure compensation filter, O-ring	VMQ or EPDM
10	Nameplates	lasered
11	Cable gland	Polyamide (PA), for dust ignition-proof: CuZn nickel-plated
12	Seal of cable gland and blind plug	NBR/Silicone/EPDM
13	Sealing ring	EPDM
14	Screw	A4-50



Connecting parts

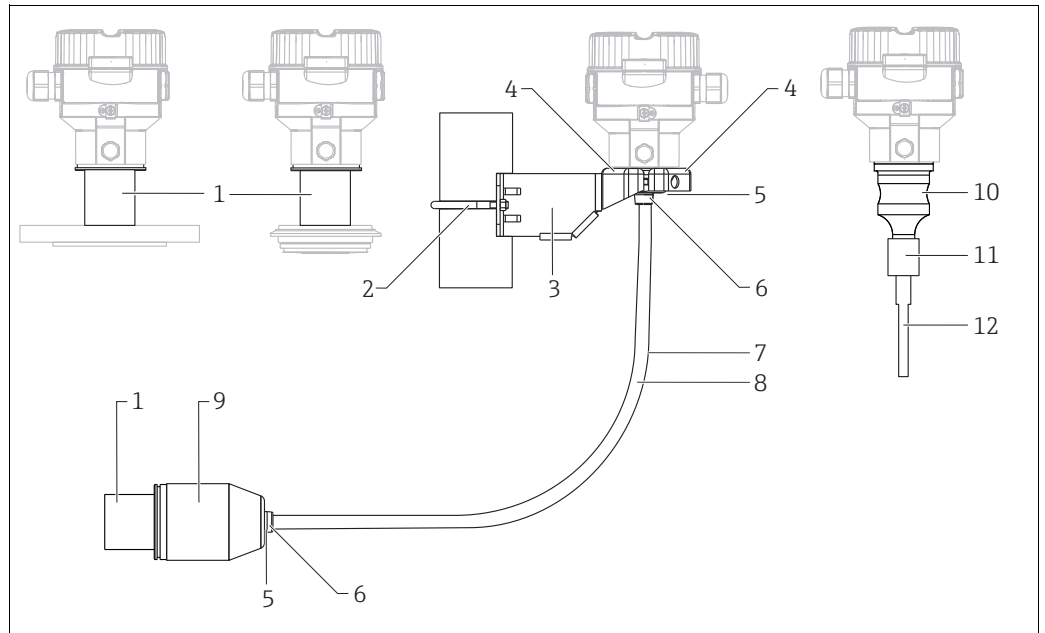

A0023900/A0032952

Item number	Component part	Material
1	Connection between the housing and process connection	AISI 316L (1.4404)
2	Mounting bracket	Bracket AISI 316L (1.4404)
3		Screw and nuts A4-70
4		Half-shells: AISI 316L (1.4404)
5	Seal for cable from Separate housing	FKM, EPDM
6	Gland for cable from separate housing: Screws:	AISI 316L (1.4404) A2
7	PE cable for separate housing	Abrasion-proof cable with strain-relief Dynema members; shielded using aluminum-coated film; insulated with polyethylene (PE-LD), black; copper wires, twisted, UV-resistant
8	FEP cable for separate housing	Abrasion-proof cable; shielded using galvanized steel wire netting; insulated with fluorinated ethylene propylene (FEP), black; copper wires, twisted, UV-resistant
9	Process connection adapter for separate housing	AISI 316L (1.4404)
10	Cell body	AISI 316L (1.4404)
11	Connection between body of measuring cell and capillary	AISI 316L (1.4404)
12	Heat-shrink tube (available only if flexible armor for capillary has PVC coating or PTFE hose)	Polyolefin

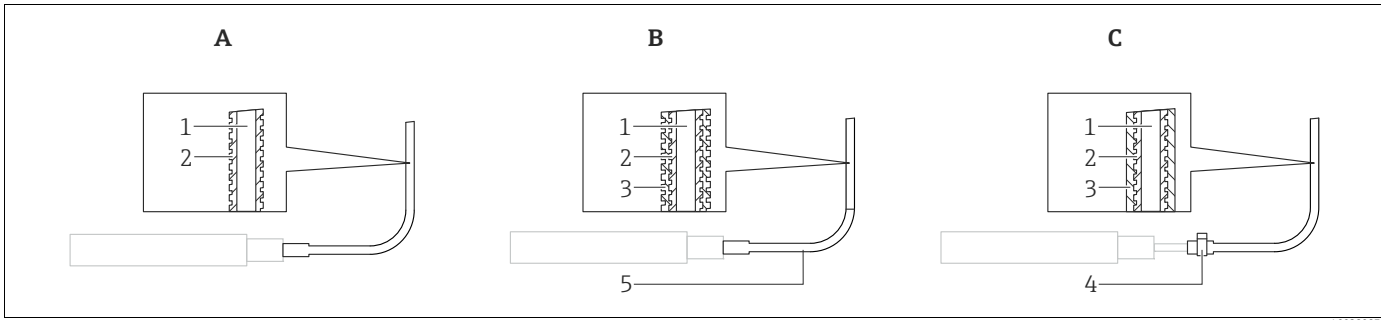

A0028087

Item	Component part	A Standard flexible capillary armoring	B PVC-coated flexible capillary armoring	C PTFE-hose flexible capillary armoring
1	Capillary	AISI 316 Ti (1.4571)	AISI 316 Ti (1.4571)	AISI 316 Ti (1.4571)
2	Flexible armor for capillary	AISI 316L (1.4404) <sup>1)</sup>	AISI 316L (1.4404)	AISI 316L (1.4404)
3	Coating/Hose	-	PVC <sup>2)</sup>	PTFE <sup>3)</sup>
4	Single-ear clamp	-	-	1.4301
5	Shrink tubing at capillary junction	-	Polyolefin	-

- 1) Product Configurator, order code for "Capillary armoring:" option "SA"
- 2) Product Configurator, order code for "Capillary armoring:" option "SB"
- 3) Product Configurator, order code for "Capillary armoring:" option "SC"

**Materials in contact with the process**



The wetted device components are listed in the "Mechanical construction" (→ 45 ff) and "Ordering information" (→ 118 ff) sections.

**Delta-ferrite content**

The delta- ferrite content of the wetted parts material can be guaranteed and certified to ≤ 3% if the option "KF" is chosen in the Product Configurator “Material of the process isolating diaphragm” ordering feature. When PMC51 with hygienic process connections is chosen, the deltaferrite content can be guaranteed and certified to ≤ 1% if the option "KF" is chosen in the Product Configurator “Material of the process isolating diaphragm” ordering feature.

**TSE Certificate of Suitability (Transmissible Spongiform Encephalopathy)**

The following applies to all process wetted device components:

- They do not contain any materials derived from animals.
- No auxiliaries or operating materials derived from animals are used in production or processing.

**Process connections**

- "Clamp connections" and "Hygienic process connections" (see also "Ordering information" ordering feature): AISI 316L (DIN/EN material number 1.4435)
- Endress+Hauser supplies process connections with threaded connections and DIN/ EN flanges made of stainless steel as per AISI 316L (DIN/EN material number 1.4404 (AISI 316) or 14435). With regard to their stability-temperature property, the materials 1.4404 and 1.4435 are grouped together under 13E0 in EN 1092-1 Tab.18. The chemical composition of the two materials can be identical.
- Some process connections are also available in the material Alloy C276 (DIN/EN material number 2.4819). See the information in the "Mechanical construction" ordering feature.

**Process isolating diaphragm**

Type	Designation	Option <sup>1)</sup>
PMC51	Al <sub>2</sub> O <sub>3</sub> aluminum oxide ceramic (FDA <sup>2)</sup> , USP Class VI+121°C), ultrapure 99.9 % (see also www.endress.com/ceraphire)	Standard
PMP51	AISI 316L (DIN/EN material number 1.4435)	A
	AISI 316L with gold-rhodium coating	M
	Alloy C276 (DIN/EN material number 2.4819)	B
PMP55	AISI 316L (DIN/EN material number 1.4435)	A
	AISI 316L, TempC	E
	AISI 316L with gold-rhodium coating	M
	AISI 316L with 0.25 mm (0.01 in) PTFE coating	S
	Alloy C276 (DIN/EN material number 2.4819)	B <sup>3)</sup>
	Monel (2.4360)	C <sup>3)</sup>
	Tantal (UNS R05200)	D <sup>3)</sup>

- 1) Product Configurator, "Material of the process isolating diaphragm" ordering feature
- 2) The US Food & Drug Administration (FDA) has no objections to the use of ceramics made from aluminum oxide as a surface material in contact with foodstuffs. This declaration is based on the FDA certificates of our ceramic suppliers.
- 3) The flange raised face is made from the same material as the process isolating diaphragm.

**Seals**

Type	Designation	Option <sup>1)</sup>
PMC51	FKM Viton	A
	FKM Viton, FDA, 3A Class I, USP Class VI	B
	FFKM Perlast G75LT	C
	NBR	F
	HNBR, FDA, 3A Class II, KTW, AFNOR, BAM	G
	NBR, Low temperature	H
	EPDM, FDA	J
	EPDM, FDA, 3A Class II, USP Class VI+121°C, DVGW, KTW, W270, WRAS, ACS, NSF61	K
	FFKM Kalrez 6375	L
	FFKM Kalrez 7075	M
	FFKM Kalrez 6221, FDA, USP Class VI	N
	Fluoroprene XP40, FDA, USP Class VI+121°C, 3A Class I	P
	VMQ Silicone, FDA	S

- 1) Product Configurator, "Seal" ordering feature

**Fill fluid**

Designation	Option PMP51 <sup>1)</sup>
Silicone oil	1
Inert oil	2
NSF-H1 synthetik oil according to FDA 21 CFR 178.3570	3

1) Product Configurator, "Fill fluid" ordering feature

Designation	Option PMP55 <sup>1) 2)</sup>
Silicone oil, suitable for foods FDA 21 CFR 175.105	1
Inert oil	2
Vegetable oil, Suitable for foods FDA 21 CFR 172.856	4
High-temperature oil	5
Low-temperature oil	6

1) Product Configurator, "Fill fluid" ordering feature

2) Only select FDA-approved filling oils for diaphragm seal devices with 3-A and EHEDG certification!

# Operability

## Operating concept

### Operator-oriented menu structure for user-specific tasks

- Commissioning
- Operation
- Diagnostics
- Expert level

### Quick and safe commissioning

Guided menus for applications

### Reliable operation

- Onsite operation possible in several languages
- Standardized operation at the device and in the operating tools
- Parameters can be locked/unlocked using the device's write protection switch, using the device software or via remote control.

### Efficient diagnostics increase measurement availability

- Remedial measures are integrated in plain text
- Diverse simulation options

## Onsite operation

### Local display (optional) for devices with HART, PROFIBUS PA or FOUNDATION Fieldbus electronics

A 4-line liquid crystal display (LCD) is used for display and operation. The local display shows measured values, dialog texts as well as fault and notice messages in plain text, thereby supporting the user at every stage of operation. The liquid crystal display of the device can be turned in 90° stages. Depending on the orientation of the device, this makes it easy to operate the device and read the measured values.

#### Functions

- 8-digit measured value display including sign and decimal point, bar graph for 4 to 20 mA HART as current display; or for PROFIBUS PA as graphic display of the standardized value of the AI Block; for FOUNDATION Fieldbus as graphic display of the transducer output in relation to the set pressure range.
- Simple and complete menu guidance as parameters are split into several levels and groups
- Each parameter is given a 3-digit ID number for easy navigation
- Possibility of configuring the display to suit individual requirements and preferences, such as language, alternating display, contrast setting, display of other measured values such as sensor temperature etc.
- Comprehensive diagnostic functions (fault and warning message, peak-hold indicators, etc.)

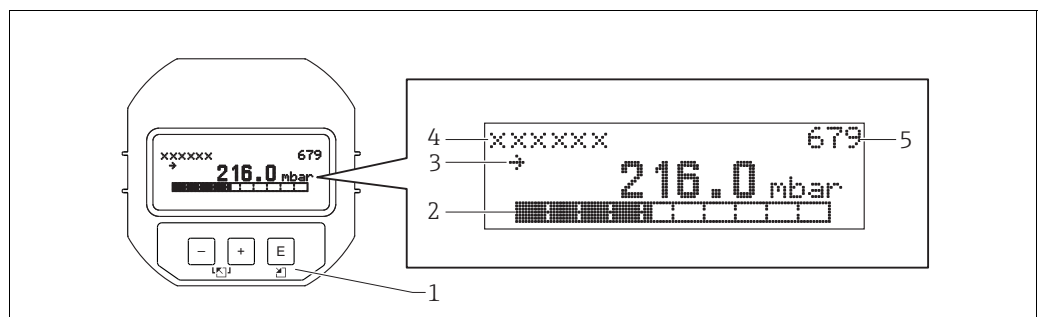

- 1 Operating keys
- 2 Bar graph
- 3 Symbol
- 4 Header
- 5 Parameter ID number

Ordering information: Product Configurator, "Output" ordering feature

Function	Operation with display			
	Analog electronics	HART	PROFIBUS PA	FOUNDATION Fieldbus
Position adjustment (zero point correction)	–	✓	✓	✓
Setting lower range value and upper range value - reference pressure present at the device	–	✓	✓	✓
Device reset	–	✓	✓	✓
Locking and unlocking parameters relevant to the measured value	–	✓	✓	✓
Value acceptance indicated by the green LED	–	–	–	–
Switching damping on and off	–	✓	✓	✓

### Local display (optional) for devices with analog electronics

A 4-line liquid crystal display (LCD) is used. The local display shows measured values, fault messages and notice messages. The liquid crystal display of the device can be turned in 90° stages. Depending on the orientation of the device, this makes it easy to operate the device and read the measured values.

Functions:

- 8-digit measured value display including sign and decimal point, bar graph for 4 to 20 mA as current display.
- Diagnostic functions (fault and warning message etc.)

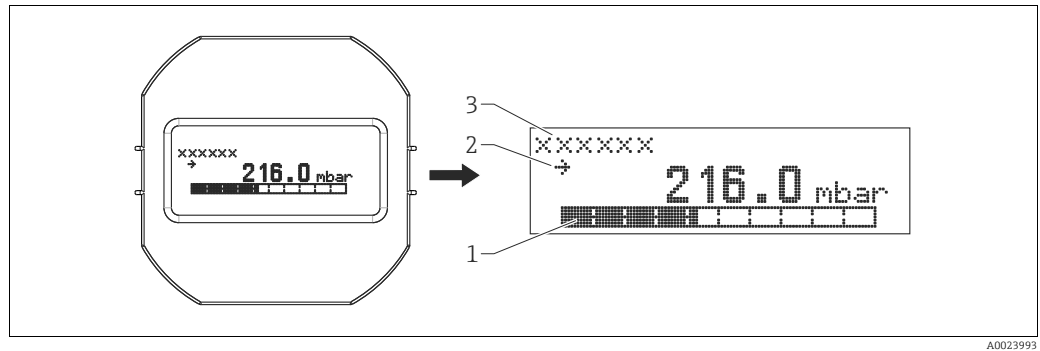

A0023993

Ordering information:  
Product Configurator, "Display, operation" ordering feature

Operating keys and elements located inside on the electronic insert

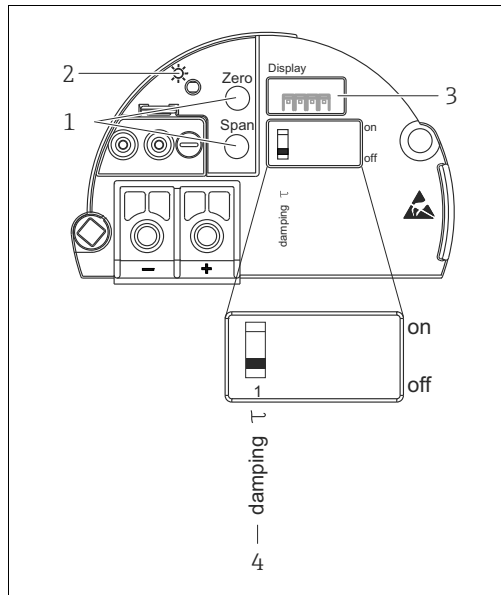

A0023992

Analog electronic insert

- 1 Operating keys for lower range value (zero), upper range value (span), position zero adjustment or reset
- 2 Green LED to indicate successful operation
- 3 Slot for optional local display
- 4 DIP switch for switching damping on/off

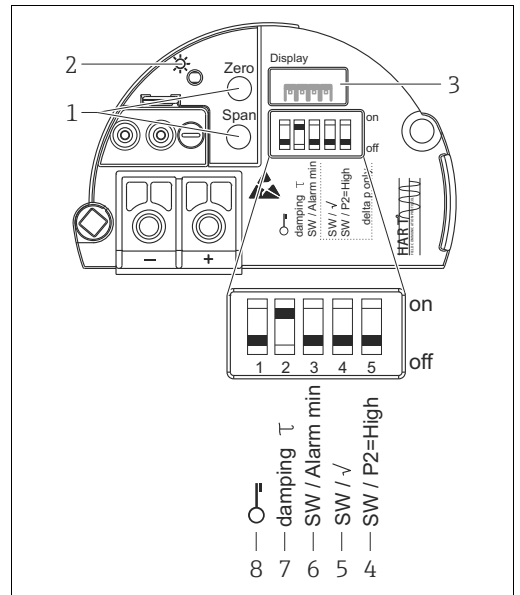

A0023125

HART electronic insert

- 1 Operating keys for lower range value (zero) and upper range value (span)
- 2 Green LED to indicate successful operation
- 3 Slot for optional local display
- 4 DIP switch only for Deltabar M
- 5 DIP switch only for Deltabar M
- 6 DIP switch for alarm current SW / Alarm Min (3.6 mA)
- 7 DIP switch for switching damping on/off
- 8 DIP switch for locking/unlocking parameters relevant to the measured value

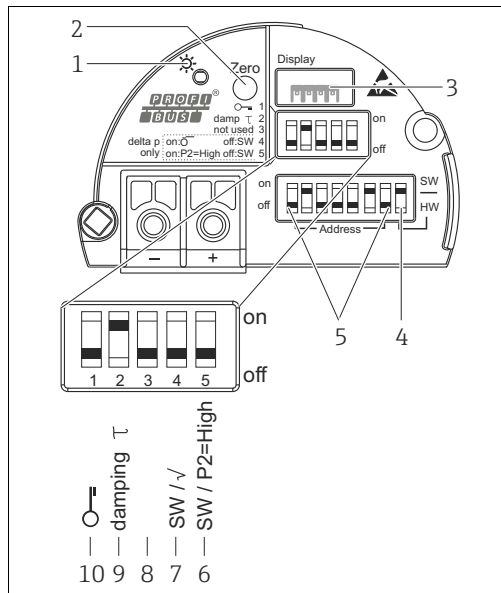

A0023126

PROFIBUS PA electronic insert

- 1 Green LED to indicate successful operation
- 2 Operating key for position zero adjustment (Zero) or reset
- 3 Slot for optional local display
- 4 DIP-switch for bus address SW / HW
- 5 DIP-switch for hardware address
- 6 DIP switch only for Deltabar M
- 7 DIP switch only for Deltabar M
- 8 Not used
- 9 DIP switch for switching damping on/off
- 10 DIP switch for locking/unlocking parameters relevant to the measured value

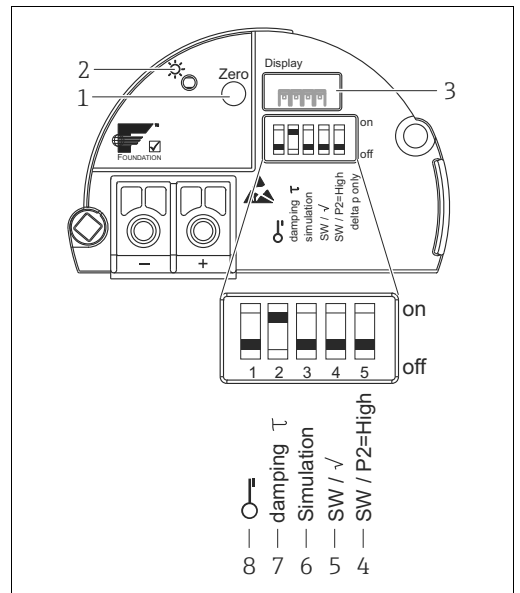

A0023127

FOUNDATION Fieldbus electronic insert

- 1 Operating key for position zero adjustment (Zero) or reset
- 2 Green LED to indicate successful operation
- 3 Slot for optional local display
- 4 DIP switch only for Deltabar M
- 5 DIP switch only for Deltabar M
- 6 DIP-switch for simulation mode
- 7 DIP switch for switching damping on/off
- 8 DIP switch for locking/unlocking parameters relevant to the measured value

Function	Operation with operating keys and elements on the electronic insert			
	Analog electronics	HART	PROFIBUS PA	FOUNDATION Fieldbus
Position adjustment (zero point correction)	✓	✓	✓	✓
Setting lower range value and upper range value - reference pressure present at the device	✓	✓	–	–
Device reset	✓	✓	✓	✓
Locking and unlocking parameters relevant to the measured value	–	✓	✓	✓
Value acceptance indicated by the green LED	✓	✓	✓	✓
Switching damping on and off	✓	✓	✓	✓

Ordering information:  
Product Configurator, "Output" ordering feature

### Operating languages

You can also choose another language in addition to the standard language "English":

Designation	Option <sup>1)</sup>
English	AA
German	AB
French	AC
Spanish	AD
Italian	AE
Dutch	AF
Chinese simplified	AK
Japanese	AL

1) Product Configurator, "Additional operating language" ordering feature

### Remote operation

All software parameters are accessible depending on the position of the write protection switch on the device.

Hardware and software for remote operation	HART	PROFIBUS PA	FOUNDATION Fieldbus
FieldCare → 104 ff	✓ <sup>1)</sup>	✓ <sup>2)</sup>	✓
FieldXpert SFX100 → 105 ff	✓	–	✓
NI-FBUS Configurator → 105 ff	–	–	✓

1) Commubox FXA195 required → 105 ff

2) Profiboard or Proficard required → 105 ff

### FieldCare

FieldCare is an Endress+Hauser asset management tool based on FDT technology. With FieldCare, you can configure all Endress+Hauser devices as well as devices from other manufacturers that support the FDT standard.

FieldCare supports the following functions:

- Configuration of transmitters in offline and online mode
- Loading and saving device data (upload/download)
- HistoROM<sup>®</sup>/M-DAT analysis
- Documentation of the measuring point



Connection options:

- HART via Commubox FXA195 and the USB port on a computer
- PROFIBUS PA via segment coupler and PROFIBUS interface card
- Service interface with Commubox FXA291 and ToF adapter FXA291 (USB).

For further information please contact your local Endress+Hauser Sales Center.

### Field Xpert SFX100

Field Xpert is an industrial PDA with integrated 3.5" touchscreen from Endress+Hauser based on Windows Mobile. It offers wireless communication via the optional VIATOR Bluetooth modem. Field Xpert also works as a stand-alone device for asset management applications. For details refer to BA00060S/00/EN.

### Commubox FXA195

For intrinsically safe HART communication with FieldCare via the USB interface. For details refer to TI00404F/00/EN.

### Commubox FXA291

The Commubox FXA291 connects Endress+Hauser field devices with a CDI interface (= Endress+Hauser Common Data Interface) and the USB port of a computer or laptop. For details, see TI00405C/07/EN.



For the following Endress+Hauser devices, you also need the "ToF adapter FXA291" accessory:

- Cerabar M
- Deltabar M
- Deltapilot M

### ToF adapter FXA291

The ToF adapter FXA291 connects the Commubox FXA291 to devices in the ToF platform, pressure devices and Gammapilot via the USB port of a computer or laptop. For details, see KA00271F.

### Profiboard

For connecting a PC to PROFIBUS.

### Proficard

For connecting a laptop to PROFIBUS.

### FF configuration program

FF configuration program, such as NI-FBUS Configurator, to

- connect devices with "FOUNDATION Fieldbus signal" into an FF-network
- set FF-specific parameters

Remote operation via:

- Operation with NI-FBUS Configurator:  
The NI-FBUS Configurator is an easy-to-use graphical environment for creating linkages, loops, and a schedule based on the fieldbus concepts.  
You can use the NI-FBUS Configurator to configure a fieldbus network as follows:
  - Set block and device tags
  - Set device addresses
  - Create and edit function block control strategies (function block applications)
  - Configure vendor-defined function and transducer blocks
  - Create and edit schedules
  - Read and write to function block control strategies (function block applications)
  - Invoke Device Description (DD) methods
  - Display DD menus
  - Download a configuration
  - Verify a configuration and compare it to a saved configuration
  - Monitor a downloaded configuration
  - Replace a virtual device by a real device
  - Save and print a configuration

**System integration (except analog electronics)**

The device can be given a tag name (max. 8 alphanumeric characters).

Designation	Option <sup>1)</sup>
Measuring point (TAG), see additional spec.	Z1
Bus address, see additional spec.	Z2

1) Product Configurator, "Identification" ordering feature

## Planning instructions for diaphragm seal systems

### NOTICE

#### Diaphragm seal systems sized/ordered incorrectly

The performance and the permitted range of application of a diaphragm seal system depend on the process isolating diaphragm used, the filling oil, the coupling, the unit design and on the specific process and ambient conditions present in the individual application.

- ▶ To help you select the right diaphragm seal systems for your particular applications, Endress+Hauser provides its customers with the "Applicator Sizing Diaphragm Seal" selection tool, which is available free of charge at [www.endress.com/applicator](http://www.endress.com/applicator) or can be ordered on a DVD.

- 1 My Applicator - Configuration of the Applicator settings
- 2 Applicator help
- 3 Mouse-Over help - slide with the mouse pointer over these fields and get short informations

For further details, or for information on an optimum diaphragm seal solution, please contact your local Endress+Hauser Sales Center.

### Applications

Diaphragm seal systems should be used if the process and the device need to be separated. Diaphragm seal systems offer clear advantages in the following instances:

- In the case of extreme process temperatures
- For aggressive media
- If extreme measuring point cleaning is necessary, or in the event of very damp mounting locations
- If the measuring point is exposed to severe vibrations
- For mounting locations that are difficult to access

## Function and design

Diaphragm seals separate the measuring system from the process.

A diaphragm seal system consists of:

- A diaphragm seal
- A capillary tube or a temperature isolator if necessary
- Fill fluid
- A pressure transmitter

The process pressure acts via the process isolating diaphragm of a diaphragm seal on the liquid-filled system, which transfers the process pressure to the sensor of the pressure transmitter.

Endress+Hauser delivers all diaphragm seal systems as welded versions. The system is hermetically sealed, which ensures greater reliability.

The diaphragm seal determines the application range of the system on the basis of

- The diameter of the process isolating diaphragm
- The process isolating diaphragm: stiffness and material
- The design (oil volume)

### Diameter of the process isolating diaphragm

The greater the diameter of the process isolating diaphragm (less stiff), the smaller the temperature effect on the measurement result.

### Stiffness of the process isolating diaphragm

The stiffness depends on the diameter of the process isolating diaphragm, the material, any existing coating, the thickness and shape of the process isolating diaphragm. The thickness of the process isolating diaphragm and the shape are determined by the design. The stiffness of a process isolating diaphragm of a diaphragm seal influences the temperature application range and the measuring error caused by temperature effects.

*The new TempC diaphragm: maximum accuracy and process safety during pressure and differential pressure measurement with diaphragm seals*

To measure with even greater accuracy in these applications and increase process safety, Endress+Hauser has developed the TempC diaphragm which is based on a completely revolutionary technology. This diaphragm guarantees the utmost level of accuracy and process safety in diaphragm seal applications.

- The very low temperature effect minimizes the effect of process and ambient temperature fluctuations, thereby guaranteeing accurate and reliable measurements. Measurement inaccuracies caused by temperature are reduced to a minimum.
- The TempC diaphragm can be used at temperatures between -40 °C (-40°F) and +250 °C (+482°F). This guarantees maximum process safety even in the event of very long sterilization and cleaning cycles (SIP/CIP) in tanks and pipes at high temperatures.
- Smaller instrumentation is possible thanks to the TempC diaphragm. With a smaller process connection, the new diaphragm measures at least as accurately as a conventional diaphragm with a larger diameter.
- Short recovery times following thermal shocks allow shorter downtimes during batch processes and therefore a far higher level of availability of the production facilities.
- In addition, the TempC diaphragm excels in terms of improved hygienic cleanability and its insensitivity to large changes in the pressure load.

Ordering information:

See the Product Configurator for the individual process connection and the choice of process isolating diaphragm.

Selection in the Applicator:

Under "Transmitter data" in the "Diaphragm material" field.

### Capillary

Capillaries with an internal diameter of 1 mm (0.04 in) are used as standard.

As a result of its length and internal diameter, the capillary tube influences the thermal change, the ambient temperature application range and the response time of a diaphragm seal system.

### Filling oil

When selecting the filling oil, the medium temperature and ambient temperature, as well as the process pressure, are of crucial importance. Observe the temperatures and pressures during commissioning and cleaning. A further selection criterion is the compatibility of the filling oil with the requirements of the medium. For example, only filling oils that do not present a health hazard are used in the food industry, e.g. vegetable oil or silicone oil. → See also the following section "Diaphragm seal filling oils".

The filling oil used influences the thermal change, the temperature application range of a diaphragm seal system and the response time. A temperature change results in a volume change in the filling oil. The volume change depends on the thermal expansion coefficient of the filling oil and on the volume of the fill fluid at calibration temperature (constant in the range: +21 to +33 °C (+70 to 91°F)). For example, the filling oil expands in the event of a temperature increase. The additional volume presses against the process isolating diaphragm of a diaphragm seal. The stiffer a process isolating diaphragm is, the greater its return force, which counteracts a volume change and acts together with the process pressure on the measuring cell, thus shifting the zero point.

### Pressure transmitter

The pressure transmitter influences the temperature application range, the thermal change and the response time as a result of its volume change. The volume change is the volume that has to be shifted in order to pass through the complete measuring range.

Pressure transmitters from Endress+Hauser are optimized with regard to minimum volume change.

### Diaphragm seal filling oils

Filling oil	Permissible temperature range at		Density [g/cm <sup>3</sup> ] / [SGU]	Viscosity [mm <sup>2</sup> /s] / [cSt] at 25 °C (77°F)	Thermal expansion coefficient <sup>1)</sup> [1/K]	Notes <sup>2)</sup>	Option <sup>3)</sup>
	0.05 bar ≤ p <sub>abs</sub> ≤ 1 bar <sup>4)</sup> (0.725 psi ≤ p <sub>abs</sub> ≤ 14.5 psi)	p <sub>abs</sub> ≥ 1 bar (p <sub>abs</sub> ≥ 14.5 psi)					
Silicone oil	-40 to +180 °C (-40 to +356°F)	-40 to +250 °C (-40 to +482°F)	0.96	100	0.00096	Suitable for foods FDA 21 CFR 175.105	1
Inert oil	-40 to +80 °C (-40 to +176°F)	-40 to +175 °C (-40 to +347°F)	1.87	27	0.000876	For ultrapure gas and oxygen applications	2
Vegetable oil	-10 to +120 °C (+14 to +248°F)	-10 to +200 °C (+14 to +392°F)	0.94	9.5	0.00101	Suitable for foods FDA 21 CFR 172.856	4
High- temperature oil	-10 to +200 °C (+14 to +392°F)	-10 to +400 °C (+14 to +752°F) <sup>5)</sup>	1.00	150	0.00096	High temperatures	5
Low-temperature oil	-70 to +80 °C (-94 to +176°F)	-70 to +180 °C (-94 to +356°F)	0.92	4.4	0.00108	Low temperatures	6

- 1) Please refer to the "Applicator Sizing Diaphragm Seal" tool for the thermal change of the diaphragm seal and other important technical features.
- 2) Only select FDA-approved filling oils for diaphragm seal devices with 3-A and EHEDG certification!
- 3) Product Configurator, "Fill fluid" ordering feature
- 4) Observe temperature limits of the device (→ 42) and of the system (→ 107).
- 5) 325 °C (617 °F) at ≥ 1 bar (14.5 psi) absolute pressure.  
350 °C (662 °F) at ≥ 1 bar (14.5 psi) absolute pressure (max. 200 hours).  
400 °C (752 °F) at ≥ 1 bar (14.5 psi) absolute pressure (max. 10 hours).

**Operating temperature range** The operating temperature range of a diaphragm seal system depends on the fill fluid, capillary length and internal diameter, process temperature and oil volume of the diaphragm seal. The range of application can be extended by using a fill fluid with a smaller expansion coefficient and a shorter capillary.

### Cleaning instructions

- Endress+Hauser offer flushing rings as accessories to clean process isolating diaphragms without taking the transmitters out of the process.  
For further information please contact your local Endress+Hauser Sales Center.

- We recommend you perform CIP (cleaning in place (hot water)) before SIP (sterilization in place (steam)) for pipe diaphragm seals. A frequent use of sterilization in place (SIP) will increase the stress on the process isolating diaphragm. Under unfavorable circumstances in the long term view we cannot exclude that a frequent temperature change could lead to a material fatigue of the process isolating diaphragm and possibly to a leakage.

## Installation instructions

### Diaphragm seal systems

- A diaphragm seal together with the transmitter form a closed, calibrated system, which is filled through openings in the diaphragm seal and in the transmitter's measurement system. These openings are sealed and must not be opened.
- In the case of devices with diaphragm seals and capillaries, the zero point shift caused by the hydrostatic pressure of the filling liquid column in the capillaries must be taken into account when selecting the measuring cell. If a measuring cell with a small measuring range is selected, a position adjustment can cause range violation.
- For devices with a temperature isolator or capillary, a suitable fastening device (mounting bracket) is recommended.
- When mounting, sufficient strain relief must be provided for the capillary line to prevent the capillary from bending (capillary bending radius  $\geq 100$  mm (3.94 in)).

### Capillary

In order to obtain more precise measurement results and to avoid a defect in the device, mount the capillaries as follows:

- Vibration-free (in order to avoid additional pressure fluctuations)
- Not in the vicinity of heating or cooling lines
- Insulate if the ambient temperature is below or above the reference temperature
- With a bending radius of  $\geq 100$  mm (3.94 in).

### Thermal insulation

The PMP55 may only be insulated up to a certain height. The maximum permitted insulation height is indicated on the devices and applies to an insulation material with a heat conductivity  $\leq 0.04$  W/(m x K) and to the maximum permitted ambient and process temperature. The data were determined under the most critical application "quiescent air".

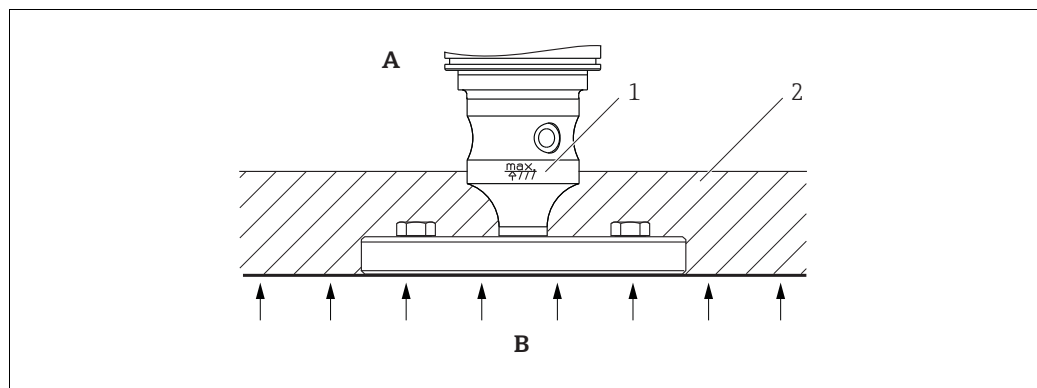

Maximum permitted insulation height, here indicated on a PMP55 with a flange

- |   |  |
|---|--|
| A | Ambient temperature: $\leq 70$ °C (158°F)  |
| B | Process temperature: max. 400 °C (752°F), depending on the diaphragm seal filling oil used |
| 1 | Maximum permitted insulation height  |
| 2 | Insulation material  |

### Mounting with temperature isolator

Endress+Hauser recommends the use of temperature isolators in the event of constant extreme medium temperatures which lead to the maximum permissible electronics temperature of +85 °C (+185 °F) being exceeded. Depending on the filling oil used, diaphragm seal systems with temperature isolators can be used for maximum temperatures of up to 400 °C (+752 °F). → For the temperature application limits, see → 109, "Diaphragm seal filling oils" section. To minimize the influence of rising heat, Endress+Hauser recommends the device be mounted horizontally or with the housing pointing downwards. The additional installation height also brings about a maximum zero point shift of 21 mbar (0.315 psi) due to the hydrostatic column in the temperature isolator. You can correct this zero point shift at the device.

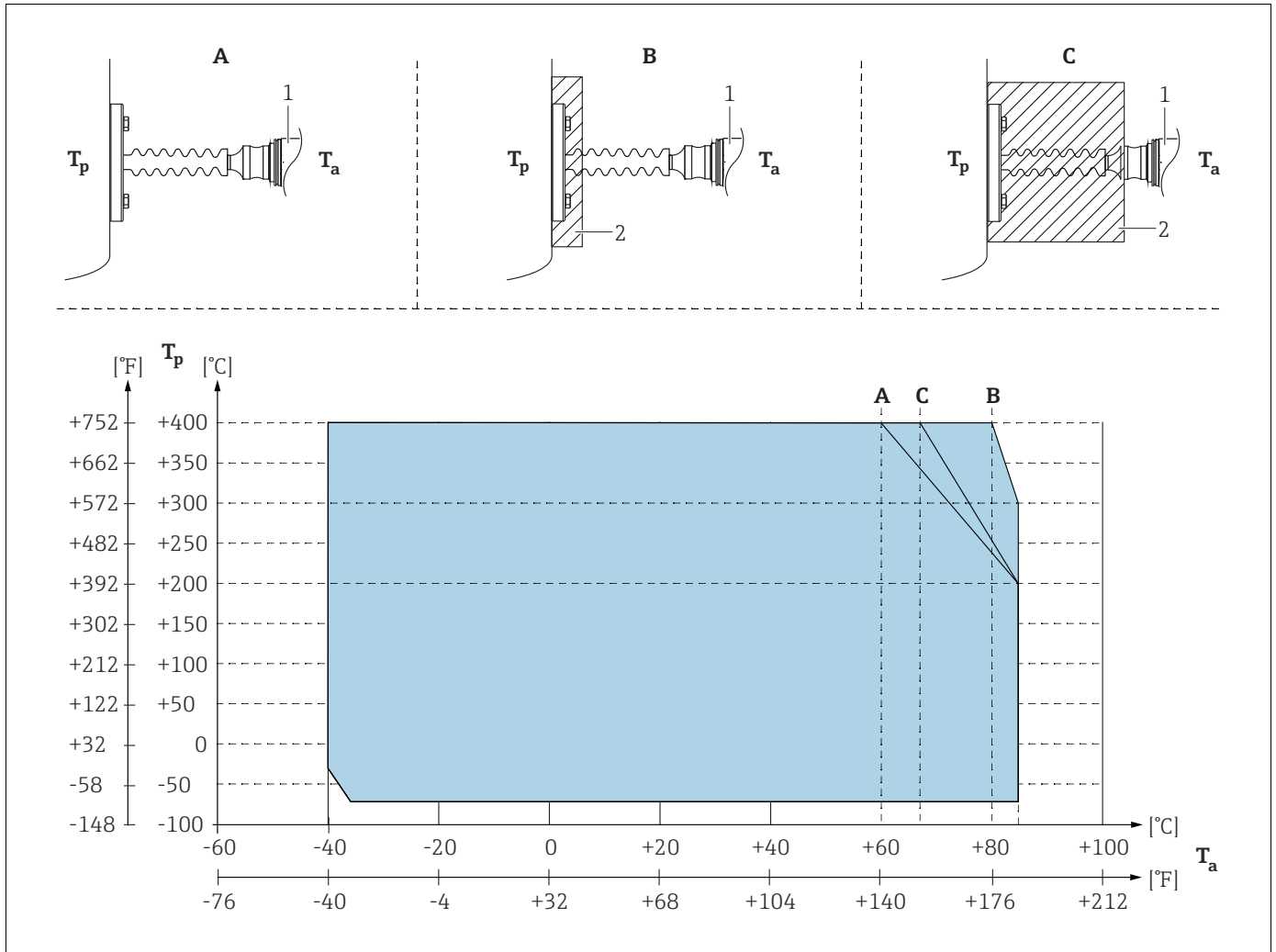

1 Transmitter  
2 Insulation material

Position	Insulation	Ambient temperature (Ta) at transmitter	Maximum process temperature (Tp)
A	No insulation	60 °C (140 °F)	400 °C (752 °F) <sup>1)</sup>
		85 °C (185 °F)	200 °C (392 °F)
B	30 mm (1.18 in) Insulation	67 °C (153 °F)	400 °C (752 °F) <sup>1)</sup>
		85 °C (185 °F)	300 °C (572 °F)
C	Maximum insulation	80 °C (176 °F)	400 °C (752 °F) <sup>1)</sup>
		85 °C (185 °F)	200 °C (392 °F)

1) Process temperature: max. 400 °C (752 °F), depending on the diaphragm seal filling oil used

**Vacuum applications**

**Mounting instructions**

For applications under vacuum, Endress+Hauser recommends mounting the pressure transmitter below the diaphragm seal. This prevents vacuum loading of the diaphragm seal caused by the presence of fill fluid in the capillary.

When the pressure transmitter is mounted above the diaphragm seal, the maximum height difference H1 in accordance with the illustrations below must not be exceeded.

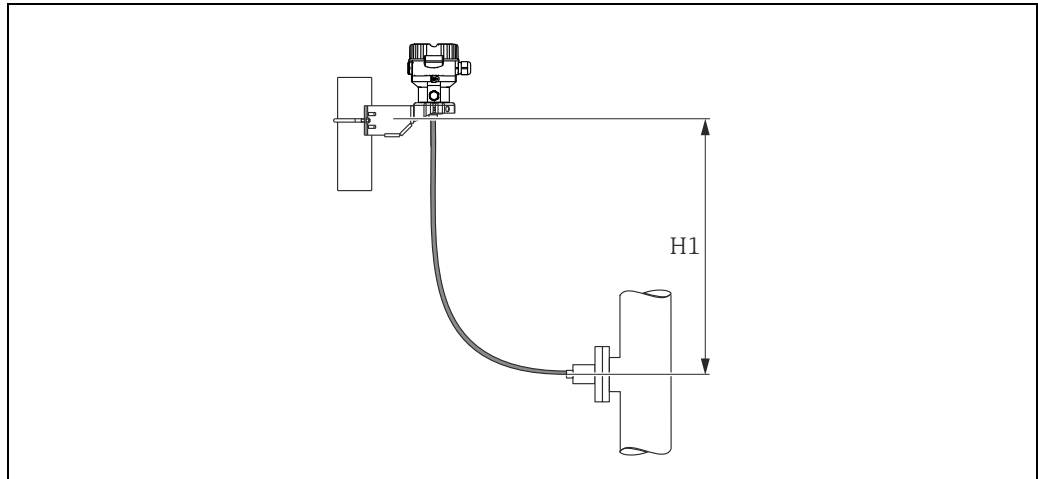

A0023994

Installation above the lower diaphragm seal

The maximum height difference depends on the density of the filling oil and the smallest ever pressure that is permitted to occur at the diaphragm seal (empty vessel), see illustration below:

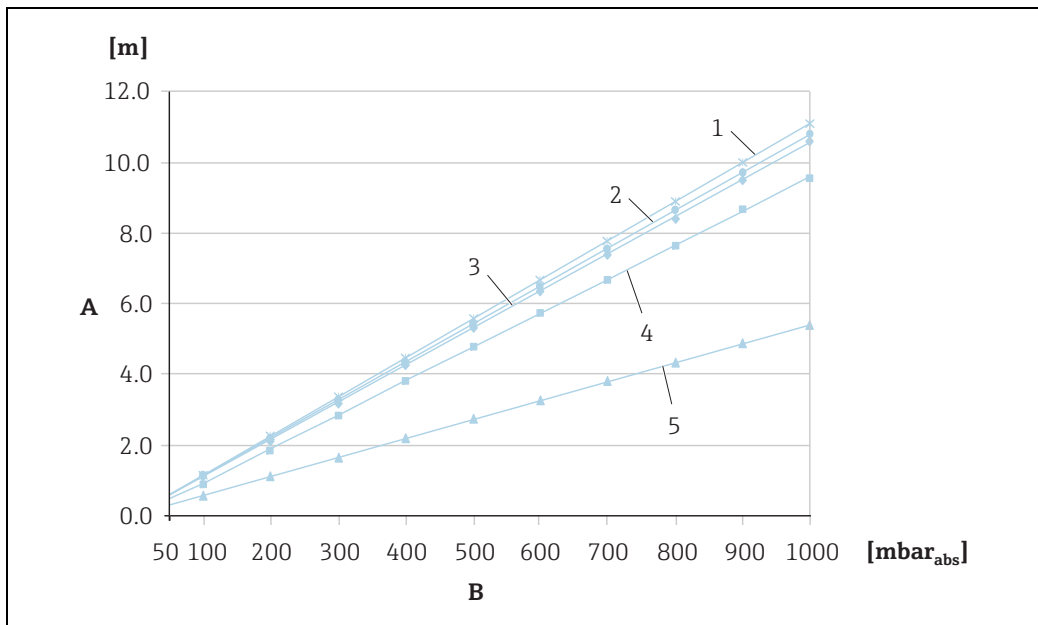

A0023986-en

Diagram of maximum installation height above the lower diaphragm seal for vacuum applications depending on the pressure at the diaphragm seal on the positive side

- A Height difference H1
- B Pressure at diaphragm seal
- 1 Low temperature oil
- 2 Vegetable oil
- 3 Silicone oil
- 4 High-temperature oil
- 5 Inert oil



## Certificates and approvals

**CE mark** The device meets the legal requirements of the relevant EC directives. Endress+Hauser confirms that the device has been successfully tested by applying the CE mark.

**RCM-Tick marking** The supplied product or measuring system meets the ACMA (Australian Communications and Media Authority) requirements for network integrity, interoperability, performance characteristics as well as health and safety regulations. Here, especially the regulatory arrangements for electromagnetic compatibility are met. The products are labelled with the RCM- Tick marking on the name plate.



A0027319-DE

**Ex approvals**

- ATEX
- IECEx
- FM
- CSA
- Also combinations of different approvals

All explosion protection data are given in separate documentation which is available upon request. The Ex documentation is supplied as standard with all devices approved for use in explosion hazardous areas. → 121 ff, "Safety Instructions" and "Installation/Control Drawings" ordering features.

**EAC conformity** The measuring system meets the legal requirements of the applicable EAC guidelines. These are listed in the corresponding EAC Declaration of Conformity together with the standards applied. Endress+Hauser confirms successful testing of the device by affixing to it the EAC mark.

**Suitable for hygiene applications** The device is available with hygienic process connections (overview: see order code). The materials of the hygienic process connections in contact with food comply with Regulation (EC) 1935/2004.

**⚠ CAUTION**

**Contamination in the process!**

Risk of contamination if incorrect seals and parts are used!

- ▶ To avoid the risk of contamination, when installing the device comply with the design principles of EHEDG, Guideline 37 "Hygienic Design and Application of Sensors" and Guideline 16 "Hygienic Pipe Couplings".
- ▶ Suitable assemblies and seals must be used to ensure hygienic design in accordance with 3-A SSI and EHEDG specifications.
- ▶ The leak-proof connections can be cleaned with the cleaning methods typical of this industry (CIP and SIP). Attention must be paid to the pressure and temperature specifications of the sensor and process connections for CIP and SIP processes (clean in place/sterilize in place).
- ▶ Only select FDA-approved filling oils for diaphragm seal devices with 3-A and EHEDG certification!

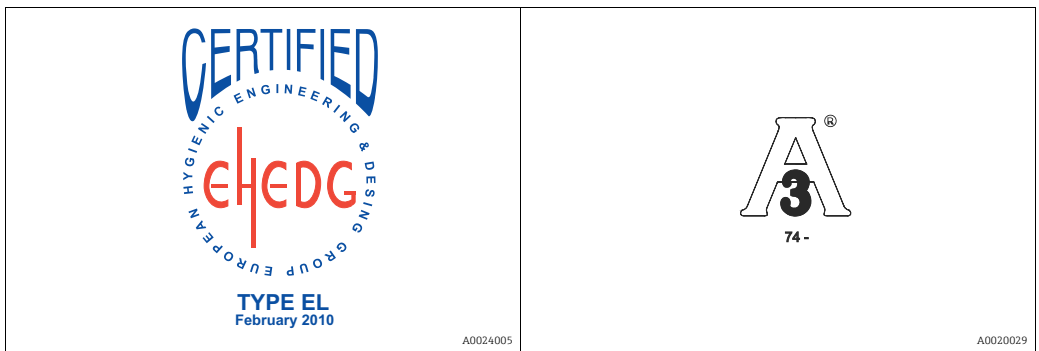

A0024005

A0020029



The gap-free connections can be cleaned of all residue using the typical cleaning methods within this industry.

---

#### Certificate of Compliance ASME BPE 2012

Ordering information:  
Product Configurator, "Additional approval" ordering feature, option "LW"

---

#### Functional safety SIL

The Cerabar M with 4 to 20 mA output signal has been developed to assessed and certified by TÜV NORD CERT as per IEC 61508 Edition 2.0 and IEC 61511. These devices can be used to monitor the process level and pressure up to SIL 2. For a detailed description of the safety functions with Cerabar M, settings and functional safety data, see the "Functional safety manual - Cerabar M" SD00347P.

Ordering information:  
Product Configurator, "Additional approval" ordering feature, option "LA"

---

#### CRN approvals

Some device versions have CRN approval. A CRN-approved process connection with a CSA approval must be ordered for a CRN-approved device. PMP55 devices with a capillary are not CRN-approved. These devices are fitted with a separate plate bearing the registration number 0F10525.5C.

Ordering information:  
Product Configurator, "Process connection" section and  
Product Configurator, "Approval" ordering feature

---

#### Standards and guidelines

DIN EN 60770 (IEC 60770):  
Transmitters for use in industrial process control systems  
Part 1: Methods for inspection and routine testing

DIN 16086:  
Electrical pressure measuring instruments, pressure sensors, pressure transmitters, pressure measuring instruments,  
concepts, specifications on data sheets

EN 61326 series:  
EMC product family standard for electrical equipment for measurement, control and laboratory use.

EN 60529:  
Degrees of protection by housing (IP code)

---

#### AD2000

The pressure retaining material 316L (1.4435/1.4404) corresponds to AD2000 - W2/W10.

---

#### Pressure Equipment Directive 2014/68/EU (PED)

##### **Pressure equipment with allowable pressure ≤ 200 bar (2 900 psi)**

Pressure equipment (having a maximum allowable pressure  $PS \leq 200$  bar (2 900 psi)) can be classified as pressurized equipment in accordance with Pressure Equipment Directive 2014/68/EU. If the maximum allowable pressure is  $\leq 200$  bar (2 900 psi) and the pressurized volume of the pressure equipment is  $\leq 0.1$  l, the pressure equipment is subject to the Pressure Equipment Directive (cf. Pressure Equipment Directive 2014/68/EU, Article 4, point 3). The Pressure Equipment Directive only requires that the pressure equipment shall be designed and manufactured in accordance with the "sound engineering practice of a Member State".

##### *Reasons:*

- Pressure Equipment Directive (PED) 2014/68/EU Article 4, point 3
- Pressure equipment directive 2014/68/EU, Commission's Working Group "Pressure", Guideline A-05 + A-06

##### *Note:*

A partial examination shall be performed for pressure instruments that are part of safety equipment for the protection of a pipe or vessel from exceeding allowable limits (equipment with safety function in accordance with Pressure Equipment Directive 2014/68/EU, Article 2, point 4).

##### **Pressure equipment with allowable pressure > 200 bar (2 900 psi)**

Pressure equipment designated for application in every process fluid having a pressurized volume of  $< 0.1$  l and a max. allowable pressure  $PS > 200$  bar (2 900 psi) shall satisfy the essential safety

requirements set out in Annex I of the Pressure Equipment Directive 2014/68/EU. According to Article 13 pressure equipment shall be classified by category in accordance with Annex II. The conformity assessment of the pressure equipment shall be determined by the category I under consideration of the above-mentioned low pressurized volume. These devices shall be provided with CE marking.

*Reasons:*

- Pressure Equipment Directive 2014/68/EU, Article 13, Annex II
- Pressure equipment directive 2014/68/EU, Commission's Working Group "Pressure", Guideline A-05

*Note:*

A partial examination shall be performed for pressure instruments that are part of safety equipment for the protection of a pipe or vessel from exceeding allowable limits (equipment with safety function in accordance with Pressure Equipment Directive 2014/68/EU, Article 2, point 4).

*The following also applies:*

- PMP51/PMP55 with threaded connection and internal process isolating diaphragm PN > 200:  
Suitable for stable gases in group 1, category I, module A
- PMP55 with pipe diaphragm seal ≥ 1.5"/PN40:  
Suitable for stable gases in group 1, category II, module A2
- PMP55 with separators PN400:  
Suitable for stable gases in group 1, category I, module A

**Manufacturer declaration**

- FDA conformity
- TSE-free, materials free from animal origin
- Regulation EC 2023/ 2006 (GMP)
- Regulation (EC) No. 1935/2004 on materials intended to come into contact with food

**Downloading the manufacturer declaration**

<http://www.endress.com/en/download>

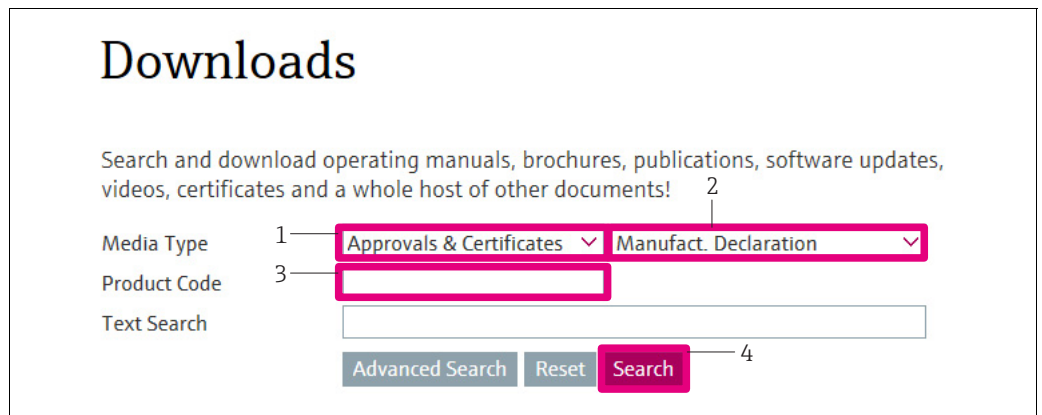

A0027319-EN

1. Enter desired product code
2. Select "Approvals & Certificates"
3. Select "Manufact. Declaration"
4. Click on "Start Search"

The available downloads are displayed.

**Marine approval**

Designation	Option <sup>1)</sup>
GL (Germanischer Lloyd)	LE
ABS (American Bureau of Shipping)	LF
LR (Lloyd's Register )	LG
BV (Bureau Veritas)	LH

Designation	Option <sup>1)</sup>
DNV (Det Norske Veritas)	LI

1) Product Configurator, "Additional approval" ordering feature

### Drinking water approval

NSF 61 - approval for PMC51 and PMP51  
 UBA / W270 - approval for PMC51 and PMP51  
 Ordering information:  
 Product Configurator, "Additional approval" ordering feature, option "LR"

### Classification of process sealing between electrical systems and (flammable or combustible) process fluids in accordance with ANSI/ISA 12.27.01

Endress+Hauser instruments are designed according to ANSI/ISA 12.27.01 either as single seal or dual seal devices with annunciation, allowing the user to waive the use and save the cost of installing external secondary process seals in the conduit as required by the process sealing sections of ANSI/NFPA 70 (NEC) and CSA 22.1 (CEC). These instruments comply with the North-American installation practice and provide a very safe and cost-saving installation for pressurized applications with hazardous fluids.  
 Further information can be found in the control drawings of the relevant devices.

### Inspection certificate

Designation	PMC51	PMP51	PMP55	Option <sup>1)</sup>
3.1 Material certificate, wetted metallic parts, EN10204-3.1 inspection certificate	✓	✓	✓	JA <sup>2)</sup>
Conformity to NACE MR0175, wetted metallic parts	✓	✓	✓	JB <sup>2)</sup>
Conformity to NACE MR0103, wetted metallic parts	✓	✓	✓	JE <sup>2)</sup>
Conformity to AD2000, wetted metallic parts, excepting process membrane	—	✓	✓	JF
Surface finish measurement ISO4287/Ra, wetted metallic parts, Inspection certificate	✓	✓	✓	KB
Helium leak test, internal procedure, inspection certificate	✓	✓	✓	KD
Pressure test, internal procedure, inspection certificate	✓	✓	✓	KE
3.1 Material certificate+Delta-Ferrit measurement, internal procedure, wetted metallic parts, EN10204-3.1 inspection certificate	✓	✓	✓	KF
3.1 Material certificate+PMI test (XRF), internal procedure, wetted metallic parts, EN10204-3.1 inspection certificate	—	✓	✓	KG
Welding documentation, wetted/pressurized seams	—	✓	—	KS

1) Product Configurator, "Test, certificate" ordering feature

2) The selection of this feature for coated process isolating diaphragm / process connections refers to the metallic base material.

### Calibration; unit

Designation	Option <sup>1)</sup>
Sensor range; %	A
Sensor range; mbar/bar	B
Sensor range; kPa/MPa	C
Sensor range; mm/mH2O	D
Sensor range; inH2O/ftH2O	E
Sensor range; psi	F
Customized pressure; see additional specification	J
Customized level; see additional specification	K

1) Product Configurator, "Calibration; unit" ordering feature

**Calibration**

Designation	Option <sup>1)</sup>
Factory calibration, 5-point	F1
DKD/DAkkS calibration certificate 10-point	F2

1) Product Configurator, "Calibration" ordering feature

**Service**

Designation	Option <sup>1)</sup>
Oil and grease removed <sup>2)</sup>	HA
Cleaned for oxygen service <sup>2)</sup>	HB
Cleaned from PWIS (PWIS = paint wetting impairment substances) <sup>2)</sup>	HC
Configured min alarm current	IA
Configured HART Burst Mode PV	IB

1) Product Configurator, "Service" ordering feature

2) Only device, not accessory or enclosed accessory

## Ordering information

Detailed ordering information is available as follows:

- In the Product Configurator on the Endress+Hauser website: [www.endress.com](http://www.endress.com) → Click "Corporate" → Select your country → Click "Products" → Select the product using the filters and search field → Open product page → The "Configure" button to the right of the product image opens the Product Configurator.
- From your Endress+Hauser Sales Center: [www.addresses.endress.com](http://www.addresses.endress.com)



### Product Configurator - the tool for individual product configuration

- Up-to-the-minute configuration data
- Depending on the device: direct input of information specific to measuring point, such as measuring range or operating language
- Automatic verification of exclusion criteria
- Automatic creation of the order code and its breakdown in PDF or Excel output format
- Ability to order directly in the Endress+Hauser Online Shop

Configuration data sheet  
(HART, PROFIBUS PA,  
FOUNDATION Fieldbus  
electronics)

### Pressure

The following configuration data sheet has to be filled in and included with the order if the option "J" has been selected in the Product Configurator, "Calibration; Unit" ordering feature.

Pressure Engineering Unit	
<input type="checkbox"/> mbar	<input type="checkbox"/> mmH <sub>2</sub> O
<input type="checkbox"/> bar	<input type="checkbox"/> mH <sub>2</sub> O
<input type="checkbox"/> psi	<input type="checkbox"/> inH <sub>2</sub> O
<input type="checkbox"/> mmHg	<input type="checkbox"/> Pa
<input type="checkbox"/> kgf/cm <sup>2</sup>	<input type="checkbox"/> kPa
<input type="checkbox"/> MPa	
Calibration Range / Output	
Low range value (LRV): _____	[pressure engineering unit]
Upper range value (URV): _____	[pressure engineering unit]
Display	
1st Value Display <sup>1)</sup>	2nd Value Display <sup>1)</sup>
<input type="checkbox"/> Main Value	<input type="checkbox"/> none (Default)
	<input type="checkbox"/> Main Value [%]
	<input type="checkbox"/> Pressure
	<input type="checkbox"/> Current [mA] (HART only)
	<input type="checkbox"/> Temperature
<sup>1)</sup> Depending on sensor and communication variant	
Damping	
Damping: _____ sec	(Default 2 sec)

Smallest calibratable measuring span (preset at the factory) → 13 ff.



**Configuration data sheet  
(analog electronics)**
**Pressure**

The following configuration data sheet has to be filled in and included with the order if the option "J" has been selected in the Product Configurator, "Calibration; Unit" ordering feature.

Pressure Engineering Unit	
<input type="checkbox"/> mbar	<input type="checkbox"/> mmH <sub>2</sub> O
<input type="checkbox"/> bar	<input type="checkbox"/> mH <sub>2</sub> O
<input type="checkbox"/> psi	<input type="checkbox"/> inH <sub>2</sub> O
<input type="checkbox"/> mmHg	<input type="checkbox"/> Pa
<input type="checkbox"/> kPa	<input type="checkbox"/> MPa
<input type="checkbox"/> kgf/cm <sup>2</sup>	
Calibration Range / Output	
Low range value (LRV): _____	[pressure engineering unit]
Upper range value (URV): _____	[pressure engineering unit]
Display	
1st Value Display <sup>1)</sup>	2nd Value Display <sup>1)</sup>
<input type="checkbox"/> Main Value	<input type="checkbox"/> none (Default)
<sup>1)</sup> Depending on sensor and communication variant	
Damping	
Damping: _____	sec (Default 2 sec)

Smallest calibratable measuring span (preset at the factory) → 13 ff.



## Documentation

**Technical Information**

- Deltabar M: TI00434P/00/EN
- Deltapilot M: TI00437P/00/EN
- EMC test procedures TI00241F/00/EN
- Weld-in adapter, process adapter and Flanges: TI00426F/00/EN

**Special Documentation**      Mechanical accessories for pressure measuring devices: SD01553P/00/EN

**Operating Instructions**

- 4 to 20 mA Analog: BA00385P/00/EN
- 4 to 20 mA HART: BA00382P/00/EN
- PROFIBUS PA: BA00383P/00/EN
- FOUNDATION Fieldbus: BA00384P/00/EN

**Brief Operating Instructions**

- 4 to 20 mA Analog: KA01036P/00/EN
- 4 to 20 mA HART: KA01030P/00/EN
- PROFIBUS PA: KA01031P/00/EN
- FOUNDATION Fieldbus: KA01032P/00/EN

**Functional safety manual (SIL)**      Cerabar M (4 to 20 mA): SD00347P/00/EN

### Safety Instructions

Directive	Approval	Category	Type	Housing		Electronics	Documentation	Option <sup>1)</sup>
				F31	F15			
ATEX	Ex ia IIC	II 1/2 G	PMC51, PMP51, PMP55	✓	✓	- 4 to 20 mA HART	- XA00464P/00	BA
	Ex t IIC	II 1/2 D	PMC51, PMP51, PMP55	✓	✓	- 4 to 20 mA HART	- XA00466P/00	BB
	Ex d	II 2 G	PMP51, PMP55	✓	-	- 4 to 20 mA HART, PROFIBUS PA, FOUNDATION Fieldbus	- XA00467P/00	BC
	Ex nA	II 3 G	PMC51, PMP51, PMP55	✓	✓	- 4 to 20 mA HART, PROFIBUS PA, FOUNDATION Fieldbus	- XA00469P/00	BD
	Ex ia IIC	II 2 G	PMC51, PMP51, PMP55	✓	✓	- 4 to 20 mA HART	- XA00464P/00	BE
	Ex ia IIC	II 1/2 D	PMC51	✓	✓	- 4 to 20 mA HART	- XA00465P/00	BF
	Ex ic IIC	II 3 G	PMC51, PMP51, PMP55	✓	✓	- 4 to 20 mA HART	- XA00489P/00	BG
	Ex ia Ex ia IIIC	II 1/2 G II 1/2 D	PMC51, PMP51, PMP55	✓	✓	- 4 to 20 mA HART	- XA00468P/00	B1
	Ex ia IIC	II 2 G II 1/2 G	PMP51, PMP55	✓	✓	- 4 to 20 mA HART	- XA00468P/00	B2
	Ex d IIC Ex ia IIC	II 2 G II 1/2 G	PMP51, PMP55	✓	-	- 4 to 20 mA HART, PROFIBUS PA, FOUNDATION Fieldbus	- XA00504P/00	8A

1) Product Configurator, "Approval" ordering feature

Directive	Approval	EPL	Type	Housing		Electronics	Documentation	Option <sup>1)</sup>
				F31	F15			
IECEX	Ex ia IIC	Ga/Gb	PMC51, PMP51, PMP55	✓	✓	- 4 to 20 mA HART	- XA00470P/00	IA
	Ex d IIC	Gb	PMP51, PMP55	✓	-	- 4 to 20 mA HART, PROFIBUS PA, FOUNDATION Fieldbus	- XA00471P/00	IB
	Ex t IIIC	Da/Db	PMP51, PMP55	✓	✓	- 4 to 20 mA HART	- XA00472P/00	ID
	Ex ic	Gc	PMC51, PMP51, PMP55	✓	✓	- 4 to 20 mA HART	- XA00488P/00	IE
	Ex ia IIIC	Da/Db	PMC51	✓	✓	- 4 to 20 mA HART	- XA00487P/00	IF
	Ex ia IIC Ex ia IIIC	Ga/Gb Da/Db	PMC51, PMP51, PMP55	✓	✓	- 4 to 20 mA HART	- XA00473P/00	I1

1) Product Configurator, "Approval" ordering feature

Directive	Approval	Type	Housing		Electronics	Documentation	Option <sup>1)</sup>
			F31	F15			
NEPSI	Ex ia IIC T6	PMC51, PMP51, PMP55	✓	✓	- 4 to 20 mA HART	- XA00533P/00	NA
NEPSI	Ex d IIC T6 Gb	PMP51, PMP55	✓	-	- 4 to 20 mA HART	- XA00515P/00	NB

1) Product Configurator, "Approval" ordering feature

Directive	Approval	Electronics	Documentation	Option <sup>1)</sup>
TIIS	Ex ia IIC T4	- 4 to 20 mA HART	-	TA

1) Product Configurator, "Approval" ordering feature

Directive	Approval	Electronics	Documentation	Option <sup>1)</sup>
INMETRO	Ex ia IIC T6...T4 Ga/Gb Ex ia IIC T6...T3 Ga/Gb	- 4 to 20 mA HART - PROFIBUS PA - FOUNDATION Fieldbus	- XA01302P/00	MA
INMETRO	Ex d IIC T6/T4 Gb	- 4 to 20 mA HART - PROFIBUS PA - FOUNDATION Fieldbus	- XA01284P/00	MB

1) Product Configurator, "Approval" ordering feature

**Installation/Control Drawings**

Directive	Approval	Type	Housing		Electronics	Documentation	Option <sup>1)</sup>
			F31	F15			
FM	FM IS Cl.I,II,III Div.1 Gr.A-G, AEx ia FM NI Cl.I Div.2 Gr.A-D FM IS: Zone 0,1,2,20,21,22/FM NI: Zone 2	PMC51, PMP51, PMP55	✓	✓	- 4 to 20 mA HART - PROFIBUS PA, FOUNDATION Fieldbus	- XA00563P/00 - XA00564P/00	FA
	FM XP Cl.I, II Div.1 Gr.A-D, AEx d (Factory sealed) Zone 1,2	PMP51, PMP55	✓	-	- 4 to 20 mA HART - PROFIBUS PA - FOUNDATION Fieldbus	- XA01163P/00	FB
	FM DIP Cl.II, III Div.1 Gr.A-D Zone 21,22	PMP51, PMP55	✓	✓	- 4 to 20 mA HART	- In preparation	FC
	FM NI Cl.I Div.2 Gr.A-D, Zone 2	PMC51, PMP51, PMP55	✓	✓	- 4 to 20 mA HART	- FM3035394	FD
	FM IS/XP Cl.I, II Div.1 Gr.A-G, Zone 1,2	PMP51, PMP55	✓	-	- 4 to 20 mA HART - PROFIBUS PA, FOUNDATION Fieldbus	- XA01160P/00 - XA00567P/00	F1
CSA	C/US IS Cl.I,II,III Div.1 Gr.A-G, C/US IS Cl.I Div.2 Gr.A-D, Ex ia	PMC51, PMP51, PMP55	✓	✓	- 4 to 20 mA HART - PROFIBUS PA, FOUNDATION Fieldbus	- XA00556P/00 - XA00558P/00	CA
	CSA C/US CP Cl.I, II Div.1 Gr.B-G, Ex d (factory sealed) Zone 1,2	PMP51, PMP55	✓	-	- 4 to 20 mA HART	- XA00577P/00	CB
	CSA C/US Cl.II, III Div.1 Gr.E-G, Zone 21,22	PMP51, PMP55	✓	✓	- 4 to 20 mA HART	- In preparation	CC
	CSA C/US IS/XP Cl.I, II Div.1 Gr.A-G/B-G, Zone 1,2	PMP51, PMP55	✓	-	- 4 to 20 mA HART - PROFIBUS PA, FOUNDATION Fieldbus	- XA00577P/00 - XA00561P/00	C1
FM CSA	FM/CSA IS + XP Cl.I, II Div.1 Gr.A-D/B-G FM IS/FM XP Cl.I, II Div.1 Gr.A-G+ CSA IS/XP Cl.I, II Div.1 Gr.A-G, Zone 1,2	PMP55	✓	-	- 4 to 20 mA HART	- In preparation	8B

1) Product Configurator, "Approval" ordering feature

**Combination certificate**

Directive	Approval	Type	Electronics	Documentation	Option <sup>1)</sup>
KEMA/ FM / CSA	ATEX II Ex ia + FM/CSA IS ATEX II 1/2G Ex ia IIC T6 + FM/CSA IS Cl.I Div.1 Gr.A-D, FM/CSA: Zone 0,1,2	PMC51	- 4 to 20 mA HART, PROFIBUS PA, FOUNDATION Fieldbus	- XA00464P/00	8C
			- 4 to 20 mA HART	- XA00556P/00 + XA00536P/00	
			- PROFIBUS PA, FOUNDATION Fieldbus	- XA00564P/00	

1) Product Configurator, "Approval" ordering feature

## Accessories

### Manifolds

→  71.

For details see SD01553P/00/EN "Mechanical accessories for pressure measuring devices".

### Additional mechanical accessories

Oval flange adapters, pressure gauge valves, shutoff valves, siphons, condensate pots, cable shortening kits, adapter test, flushing rings, block&amp;bleed valves, protective roofs.

For details see SD01553P/00/EN "Mechanical accessories for pressure measuring devices".

### Welding necks and Weld-in tool flanges

For dimensions and technical data see technical Information TI00426F/00.

Designation	PMC51	PMP51	PMP55	Option <sup>1)</sup>
Weld-in adapter G1/2, 316L,	–	✓	✓	QA
Weld-in adapter G1/2, 316L, 3.1 EN10204-3.1 material, inspection certificate	–	✓	✓	QB
Weld-in tool adapter G1/2, Brass	–	✓	✓	QC
Weld-in adapter G1, 316L, conical metal joint	–	✓	–	QE
Weld-in adapter G1, 316L, 3.1 EN10204-3.1 material, inspection certificate, conical metal joint	–	✓	–	QF
Weld-in tool adapter G1, Brass conical metal joint	–	✓	–	QG
Weld-in adapter G1-1/2, 316L	✓	✓	✓	QJ
Weld-in adapter G1-1/2, 316L, 3.1 EN10204-3.1 material, inspection certificate	✓	✓	✓	QK
Weld-in tool adapter G1-1/2, Brass	✓	✓	✓	QL
Weld-in flange DRD DN50 65mm, 316L	✓	✓	✓	QP
Weld-in fl. DRD DN50 65mm, 316L 3.1 EN10204-3.1 material, inspection certificate	✓	✓	✓	QR
Weld-in tool flange DRD DN50 65mm, Brass	✓	✓	✓	QS
Weld-in adapter Uni D65, 316L	✓	–	–	QT
Weld-in adapter Uni D65, 316L, 3.1 EN10204-3.1 material, inspection certificate	✓	–	–	QU
Weld-in tool adapter Uni D65/D85, Brass	✓	–	–	Q1
Weld-in adapter Uni D85, 316L	✓	–	–	Q2
Weld-in adapter Uni D85, 316L, 3.1 EN10204-3.1 material, inspection certificate	✓	–	–	Q3
Adapter Uni > DIN11851 DN40, 316L, slotted-nut	✓	–	–	RA
Adapter Uni > DIN11851 DN50, 316L, slotted-nut	✓	–	–	RB
Adapter Uni > DRD DN50 65mm, 316L	✓	–	–	RC
Adapter Uni > Clamp 2", 316L	✓	–	–	RD
Adapter Uni > Clamp 3", 316L	✓	–	–	RE
Adapter Uni > Varivent N, 316L	✓	–	–	RF
Adapter Uni > Cherry Burell 2", 316L	✓	–	–	RH
Adapter Uni > DIN11851 DN40, 316L, 3.1, slotted-nut, EN10204-3.1 material, inspection certificate	✓	–	–	R1
Adapter Uni > DIN11851 DN50, 316L, 3.1, slotted-nut, EN10204-3.1 material, inspection certificate	✓	–	–	R2
Adapter Uni > DRD DN50 65mm, 316L, 3.1 EN10204-3.1 material, inspection certificate	✓	–	–	R3
Adapter Uni > Clamp 2", 316L, 3.1 EN10204-3.1 material, inspection certificate	✓	–	–	R4
Adapter Uni > Clamp 3", 316L, 3.1 EN10204-3.1 material, inspection certificate	✓	–	–	R5
Adapter Uni > Varivent, 316L, 3.1 EN10204-3.1 material, inspection certificate	✓	–	–	R6
Adapter Uni > Cherry Burell, 316L, 3.1 EN10204-3.1 material, inspection certificate	✓	–	–	R7

1) Product Configurator, "Accessories" ordering feature

---

**Mounting bracket for wall  
and pipe mounting** →  37 ff

---

**M12 connector** →  25 ff

## Registered trademarks

---

**HART®** Registered trademark of the FieldComm Group, Austin, USA

---

**PROFIBUS®** Registered trademark of the PROFIBUS User Organization, Karlsruhe, Germany

---

**FOUNDATION™ Fieldbus** Registered trademark of the FieldComm Group, Austin, USA



[www.addresses.endress.com](http://www.addresses.endress.com)

---