



Level



Pressure



Flow



Temperature

Liquid
Analysis

Registration

Systems
Components

Services



Solutions

Technical Information

Prosonic M FMU40/41/42/43/44

Ultrasonic Level Measurement

Compact transmitters for non-contact level measurement of fluids, pastes and coarse bulk materials



Application

- Continuous, non-contact level measurement in fluids, pastes, sullages and coarse bulk materials
- Flow measurement in open channels and measuring weirs
- System integration via:
 - HART (standard), 4...20mA
 - PROFIBUS PA
 - Foundation Fieldbus
- Maximum measuring range:
 - FMU 40: 5 m in fluids / 2 m in bulk materials
 - FMU 41: 8 m in fluids / 3,5 m in bulk materials
 - FMU 42: 10 m in fluids / 5 m in bulk materials
 - FMU 43: 15 m in fluids / 7 m in bulk materials
 - FMU44: 20 m in fluids / 10 m in bulk materials

Features and benefits

- Quick and simple commissioning via menu-guided on-site operation with four-line plain text display
- Envelope curves on the on-site display for simple diagnosis
- Easy remote operation, diagnosis and measuring point documentation with the supplied ToF Tool operating program.
- Suitable for explosion hazardous areas (Gas-Ex, Dust-Ex)
- Linearisation function (up to 32 points) for conversion of the measured value into any unit of length, volume or flow rate
- Non-contact measurement method minimizes service requirements
- optional remote display and operation (up to 20 m from transmitter)
- Installation possible from thread G 1½" or 1½ NPT upwards
- Integrated temperature sensor for automatic correction of the temperature dependent sound velocity

Inhaltsverzeichnis

Function and system design	3	Process conditions	21
Measuring principle	3	Process temperature	21
Equipment architecture	4	Process pressure	21
Input	8	Mechanical construction	22
Measured variable	8	Design; dimensions	22
Measuring range	8	Weight	24
Operating frequency	9	Housing design	25
Output	10	Process connection, sealing material, sensor material	25
Output signal	10	Human interface	26
Signal on alarm	10	Display and operating elements	26
Load HART	10	On-site operation	27
Output damping	10	Remote operation	28
Linearisation	10	Certificates and Approvals	30
Auxiliary energy	11	CE mark	30
Terminal compartment	11	Ex approval	30
Terminal assignment	11	External standards and guidelines	30
Fieldbus plug connectors	12	Ordering information	31
Supply voltage	13	Product structure FMU 40	31
Terminals	13	Product structure FMU 41	32
Cable entry	13	Product structure FMU 42	33
Power consumption	13	Product structure FMU 43	35
Current consumption (2-wire-instruments)	13	Product structure FMU 44	36
HART ripple	14	Scope of delivery	37
Max. noise HART	14	Accessories	38
Galvanic isolation	14	Weather protection cover	38
Performance characteristics	15	Installation bracket for FMU 40/41	38
Reaction time	15	Adapter flange	39
Reference operating conditions	15	Cantilever	40
Measured value resolution	15	Mounting Frame	41
Pulse frequency	15	Wall Bracket	41
Measuring error	15	Commubox FXA191 HART	41
Influence of the vapor pressure	15	Commubox FXA195 HART	41
Installation conditions	16	Service Interface FXA193	42
Installation variants FMU 40, FMU 41	16	Remote display FHX40	43
Installation variants FMU42, FMU44	16	Supplementary documentation	44
Installation variants FMU 43	17	System Information	44
Installation conditions for level measurements	17	Operating manual	44
Installation in narrow shafts	18	Description of device functions	44
Installation conditions for flow measurements	18	Short instructions	44
Blocking distance, nozzle installation	20	Safety Instructions ATEX	44
Ambient conditions	21	Safety Instructions NEPSI	46
Ambient temperature	21	Control drawings Installation drawings	47
Storage temperature	21		
Resistance to alternating temperature cycles	21		
Climate class	21		
Ingress protection	21		
Vibration resistance	21		
Electromagnetic compatibility (EMC)	21		

Function and system design

Measuring principle

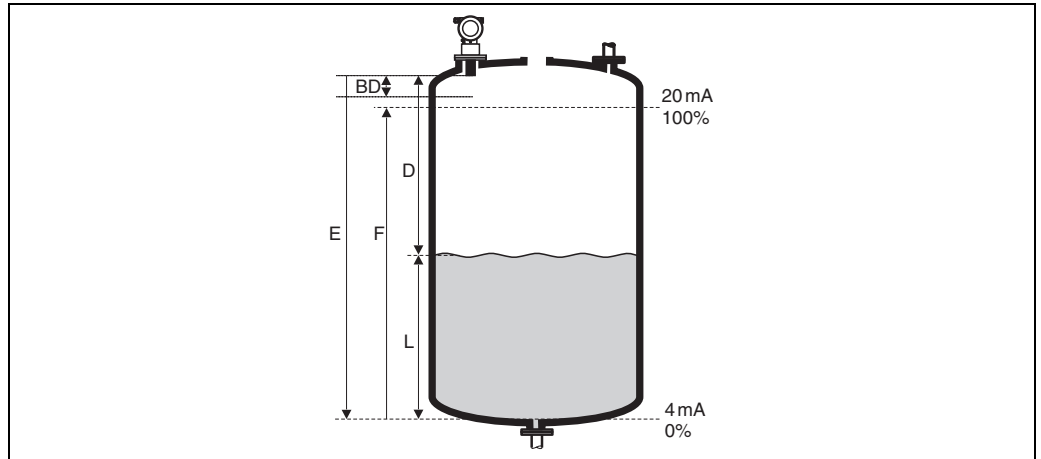

E: Empty distance; **F:** Span (full distance); **D:** Distance from sensor membrane – product surface; **L:** Level; **BD:** Blocking distance

Sensor	BD	Max. range fluids	Max. range bulk materials
FMU40	0.25 m	5 m	2 m
FMU41	0.35 m	8 m	3.5 m
FMU42	0.4 m	10 m	5 m
FMU43	0.6 m	15 m	7 m
FMU44	0.5 m	20 m	10 m

Time-of-flight method

The sensor of the Prosonic M transmits ultrasonic pulses in the direction of the product surface. There, they are reflected back and received by the sensor. The Prosonic M measures the time t between pulse transmission and reception. The instrument uses the time t (and the velocity of sound c) to calculate the distance D between the sensor membrane and the product surface:

$$D = c \cdot t / 2$$

As the device knows the empty distance E from a user entry, it can calculate the level as follows:

$$L = E - D$$

An integrated temperature sensor compensates for changes in the velocity of sound caused by temperature changes.

Interference echo suppression

The interference echo suppression feature on the Prosonic M ensures that interference echos (e.g. from edges, welded joints and installations) are not interpreted as a level echo.

Calibration

Enter the empty distance E and the span F to calibrate the device.

Blocking distance

Span F may not extend into the blocking distance BD . Level echos from the blocking distance cannot be evaluated due to the transient characteristics of the sensor.

Equipment architecture

4...20 mA output with HART protocol

The complete measuring system consists of:

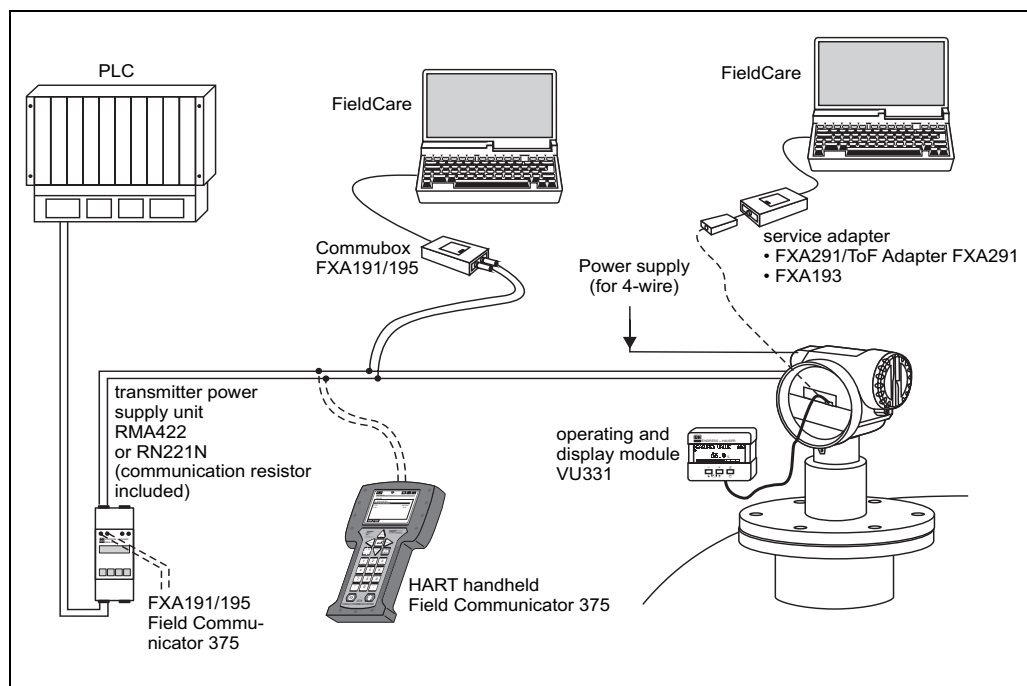

If the HART communication resistor is not built into the supply unit, it is necessary to insert a communication resistor of 250 Ω into the 2-wire line.

On-site operation

- with display and operating module VU 331
- with a Personal Computer, FXA 193 and the operating software ToF Tool

Remote operation

- with HART handheld terminal DXR 375
- with a Personal Computer, Commubox FXA 191 and the operating software COMMUWIN II respectively ToF Tool.

System integration using PROFIBUS PA

A maximum of 32 transmitters (8 if mounted in an explosion hazardous location EEx ia IIC according to FISCO-model) can be connected to the bus. The segment coupler provides the operating voltage to the bus. Both on-site as well as remote operation are possible.

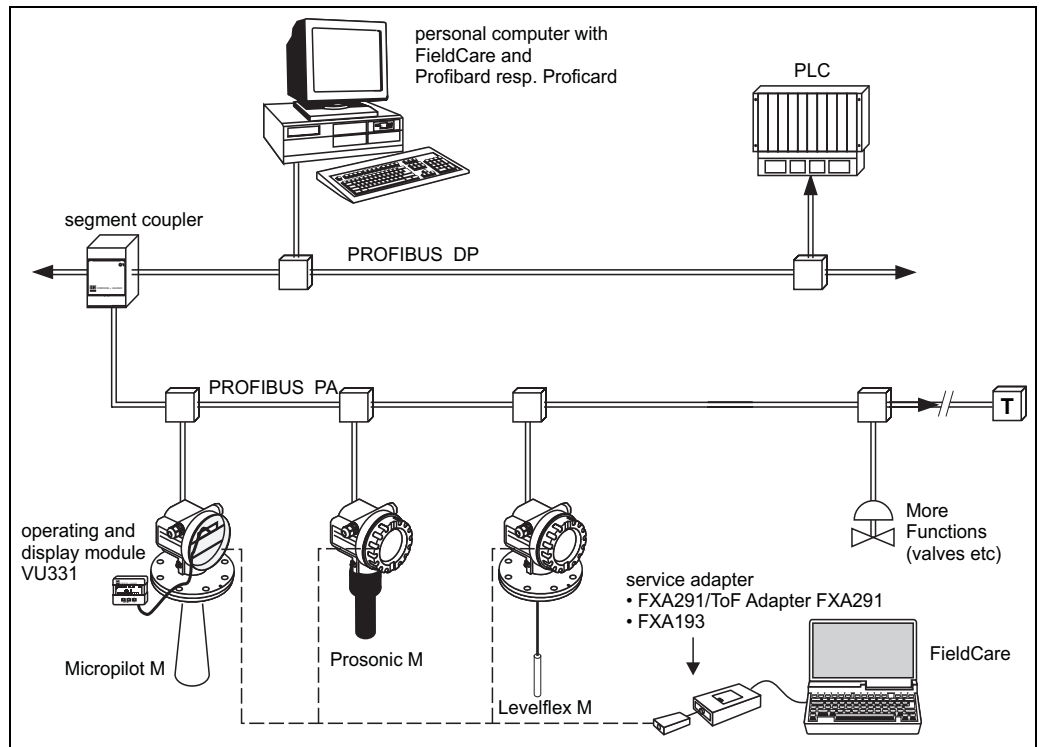

L00-FMxxxXXXX-14-00-06-en-001

System integration using Foundation Fieldbus (FF)

A maximum of 32 transmitters (standard or EEx d) can be connected to the bus. For protection class EEx ia: the maximum number of transmitters depends on the established rules and standards for intrinsically safe circuits (EN 60070-14) and proof of intrinsic safety. Both on-site and remote operation are possible.

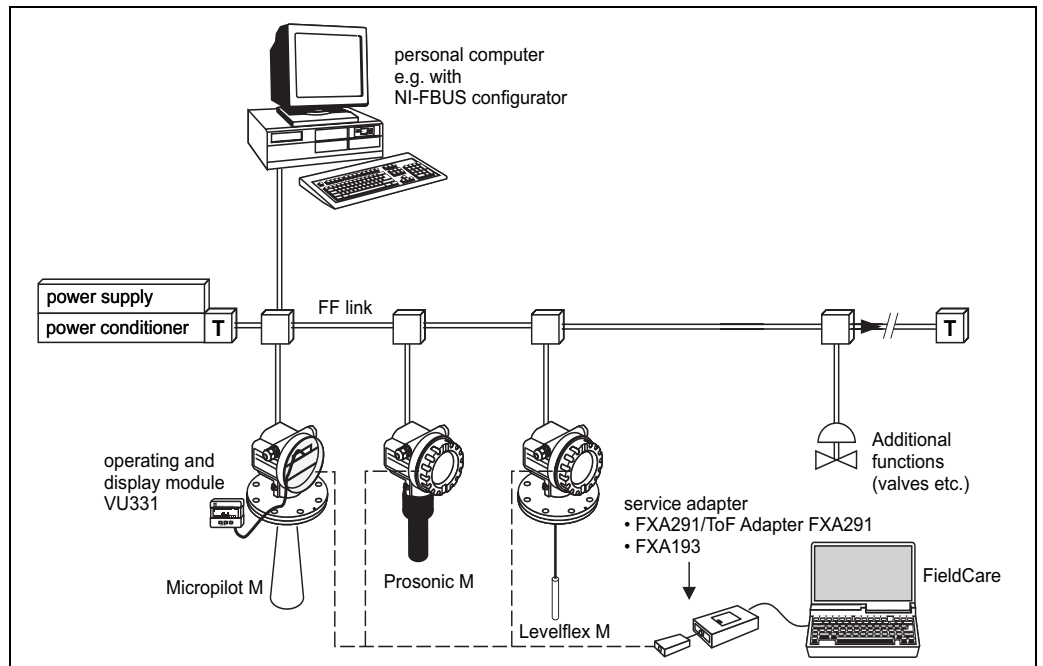

L00-FMxxxXXXX-14-00-06-en-003

System integration using Endress+Hauser Rackbus

You can interconnect a maximum of 64 2-wire devices with HART protocol to a Rackbus. Use an FXN 672 interface module for each device. You can integrate this bus into a higher-level bus by using a ZA gateway. Gateways are available for MODBUS, FIP, PROFIBUS, INTERBUS etc. Both on-site and remote operation are possible.

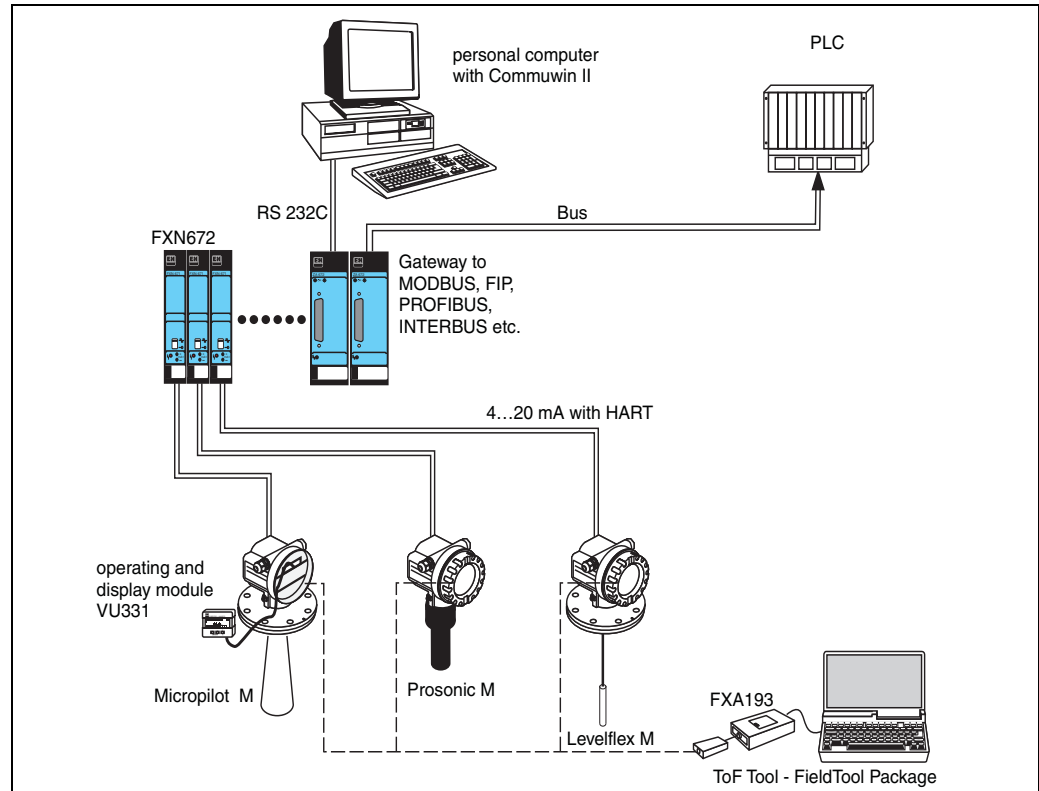

100-FMxxXXXX-14-00-06-en-006



Hinweis!

The FXN672 can be used with all 2-wire devices of the Prosonic M family.

System integration via Fieldgate

Vendor Managed Inventory

By using Fieldgates to interrogate tank or silo levels remotely, suppliers of raw materials can provide their regular customers with information about the current supplies at any time and, for example, account for them in their own production planning. For their part, the Fieldgates monitor the configured level limits and, if required, automatically activate the next supply. The spectrum of options here ranges from a simple purchasing requisition via e-mail through to fully automatic order administration by coupling XML data into the planning systems on both sides.

Remote maintenance of measuring equipment

Fieldgates not only transfer the current measured values, they also alert the responsible standby personnel, if required, via e-mail or SMS. In the event of an alarm or also when performing routine checks, service technicians can diagnose and configure connected HART devices remotely. All that is required for this is the corresponding HART operating software (e.g. ToF Tool - FieldTool Package, FieldCare, ...) for the connected device. Fieldgate passes on the information transparently, so that all options for the respective operating software are available remotely. Some on-site service operations can be avoided by using remote diagnosis and remote configuration and all others can at least be better planned and prepared.

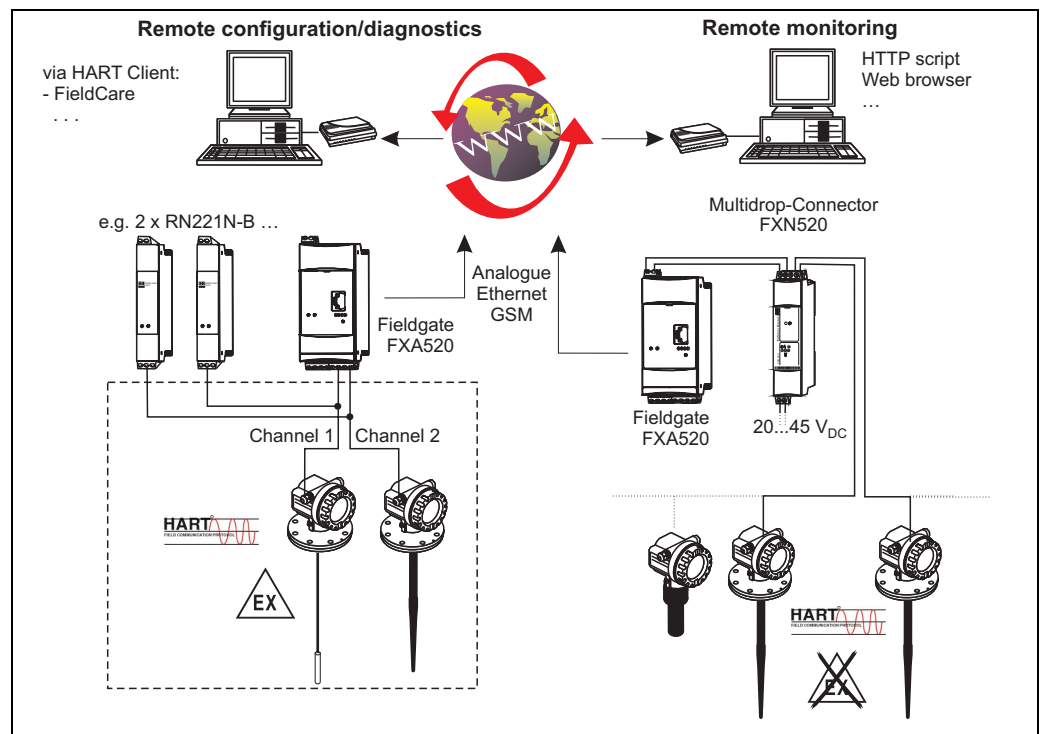

Note!

The number of instruments which can be connected in multidrop mode can be calculated by the "FieldNetCalc" program. A description of this program can be found in Technical Information TI 400F (Multidrop Connector FXN520). The program is available from your Endress+Hauser sales organisation or in the internet at: "www.endress.com → Download" (Text Search = "Fieldnetcalc").

Input

Measured variable

The distance D between the sensor membrane and the product surface is measured.

Using the linearisation function, the device uses D to calculate:

- level L in any units
- volume V in any units
- flow Q across measuring weirs or open channels in any units

Measuring range

The measuring range is limited by the range of a sensor. The sensor range is, in turn, dependent on the operating conditions. To estimate the actual range, proceed as follows (see also the calculation example in the diagram):

1. Determine which of the influences shown in the following table are appropriate for your process.
2. Add the corresponding attenuation values.
3. From the total attenuation, use the diagram to calculate the range.

Fluid surface	Attenuation
Calm	0 dB
Waves	5 ... 10 dB
Strong turbulence (e.g. stirrers)	10 ... 20 dB
Foaming	Ask Endress+Hauser

Bulk material surface	Attenuation
Hard, rough (e.g. rubble)	40 dB
Soft (e.g. peat, dust-covered clinker)	40 ... 60 dB

Dust	Attenuation
No dust formation	0 dB
Little dust formation	5 dB
Heavy dust formation	5 ... 20 dB

Filling curtain in detection range	Attenuation
None	0 dB
Small quantities	5 ... 10 dB
Large quantities	10 ... 40 dB

Temperature difference between sensor and product surface	Attenuation
to 20 °C	0 dB
to 40 °C	5 ... 10 dB
to 80 °C	10 ... 20 dB

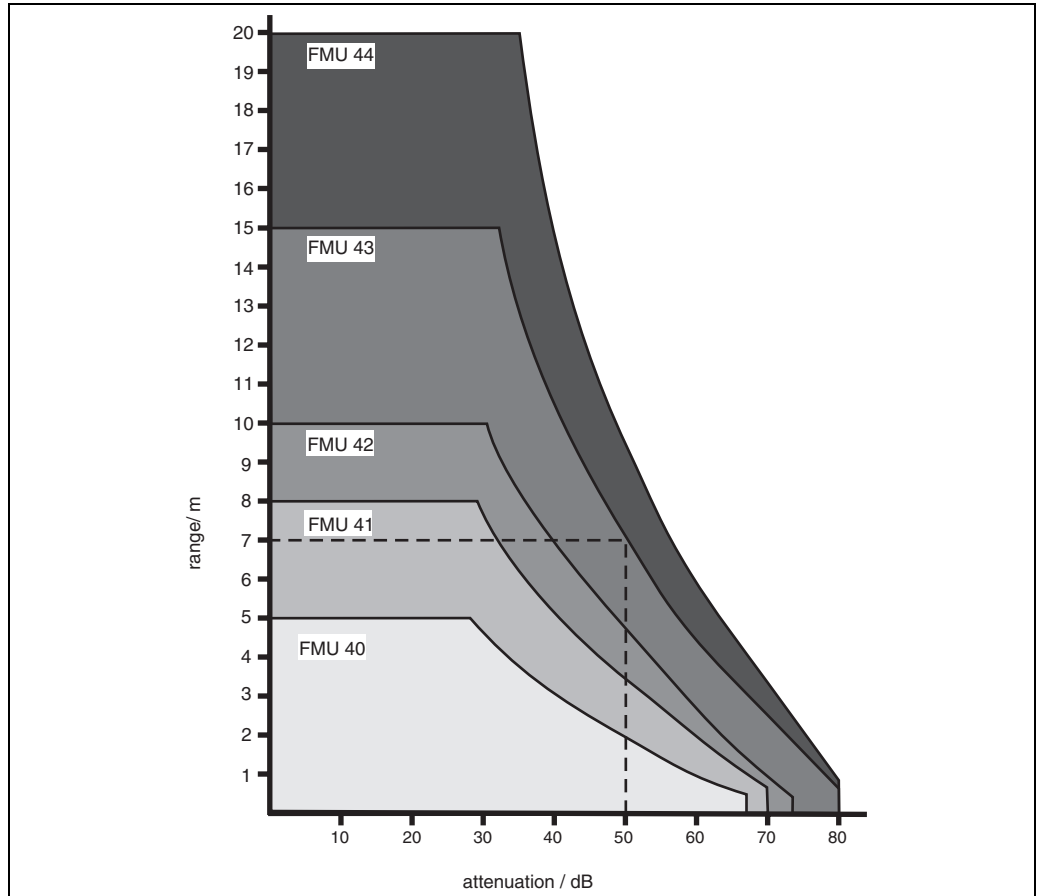

L00-FMU4xxxx-05-00-00-en-002

Example (for FMU 43)

For typical solid applications, a certain amount of dust coverage is normally present. Therefore, the following range results from the table and the diagram

- Dust-covered rubble approx. 50 dB
 - no dust formation 0 dB
 - No filling curtain in detection range 0 dB
 - Temperature diff. < 20°C 0 dB
- approx. 50 dB
=> range approx. 7 m

These measuring conditions have been taken into account during the calculation of the maximum measuring range in solid applications.

Operating frequency

Sensor	Operating frequency
FMU40	approx. 70 kHz
FMU41	approx. 50 kHz
FMU42	approx. 42 kHz
FMU43	approx. 35 kHz
FMU44	approx. 30 kHz

Output

Output signal	according to the instrument version ordered: <ul style="list-style-type: none">■ 4...20 mA with HART protocol■ PROFIBUS PA■ Foundation Fieldbus (FF)
Signal on alarm	Error information can be accessed via the following interfaces: <ul style="list-style-type: none">■ On-site display (error symbol, error code and plain text description)■ Current output (error current configurable)■ Digital interface
Load HART	Minimum load for HART communication: 250 Ω
Output damping	Freely selectable, 0 ... 255 s
Linearisation	<p>The linearisation function of the Prosonic M allows conversion of the measured value into any unit of length or volume. In open channels or measuring weirs, also a flow linearisation is possible (calculation of the flow from the measured level). The linearisation table for calculating the volume in an horizontal cylindrical tank is preprogrammed. You can also enter any number of other tables containing up to 32 value pairs either manually or semi-automatically (by filling the vessel under controlled conditions).</p> <p>The supplied ToF Tool operating program can automatically calculate the table for any tank, weir or flume and upload it into the device.</p> <p>Flow curves for open channels can be calculated and entered into the instrument by the ToT Tool as well.</p>

Auxiliary energy

Terminal compartment

In the F12 housing, the terminals are located underneath the housing cover. In the T12 housing, they are under the cover of the separate terminal compartment.

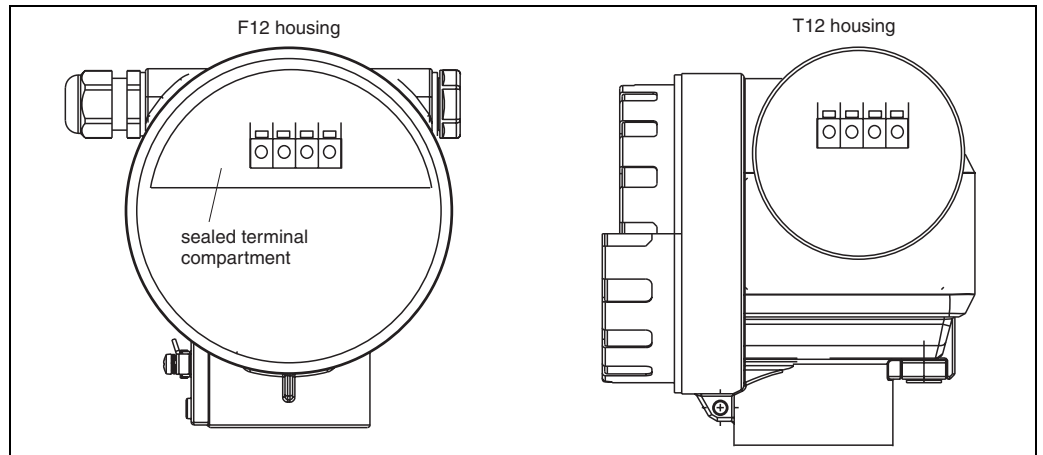

L00-FMR2xxxx-04-00-00-en-001

Terminal assignment

4 ... 20 mA with HART, 2-wire

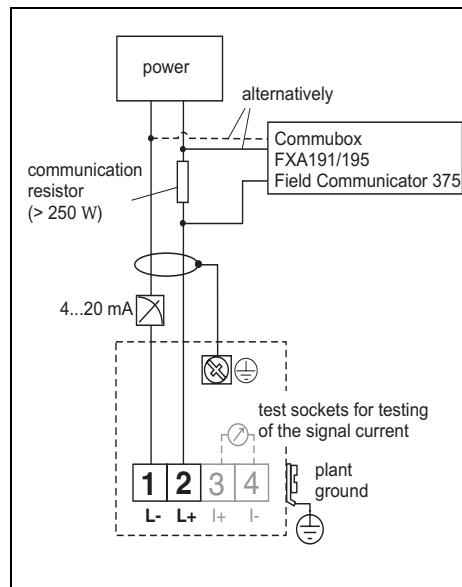

L00-FMxxxxxx-04-00-00-en-015

4 ... 20 mA active with HART, 4-wire

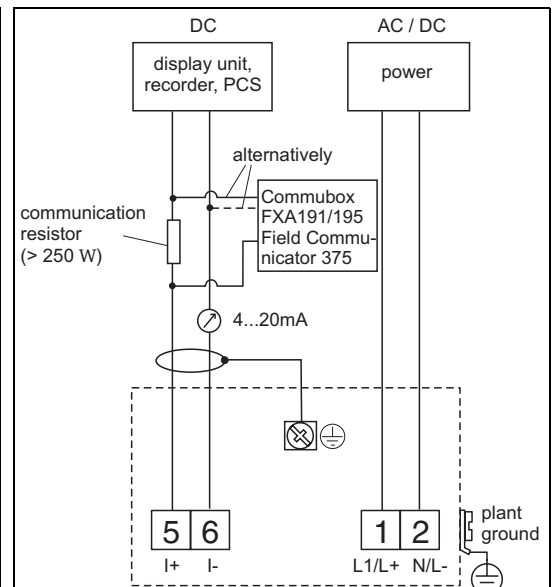

L00-FMxxxxxx-04-00-00-en-011

- Connect the connecting line to the screw terminals (line cross-sections of 0.5 ... 2.5 mm) in the terminal compartment.
- Use 2-wire twisted pair cable with screen for the connection.
- Protective circuitry against reverse polarity, RFI and over-voltage peaks is built into the device (see also Technical Information TI 241F/00/en "EMC Test Procedures")

PROFIBUS PA

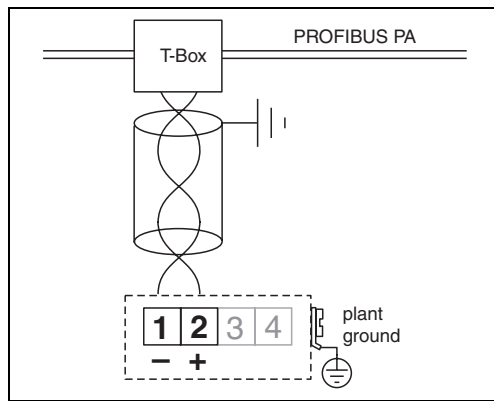

L00-FMxxxxxx-04-00-00-en-012

Foundation Fieldbus

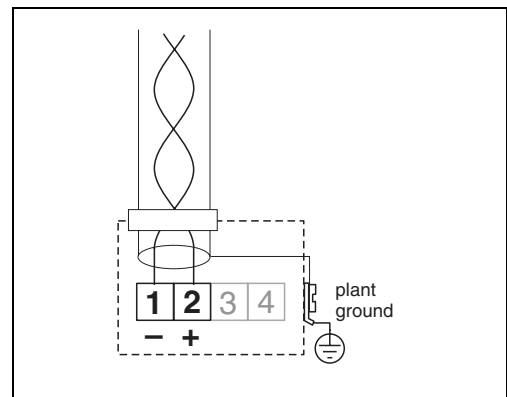

L00-FMxxxxxx-04-00-00-en-013

The digital communication signal is transmitted to the bus via a 2-wire connection. The bus also provides the auxiliary energy. Use 2-wire twisted pair cable with screen.

Refer to the following operating manuals for information on cable types, and how to set up and ground the network:

- BA 198F/00/de „PROFIBIS -DP/-PA, Guidelines for planning and commissioning“
- BA 013S/04/en „Foundation Fieldbus, Installation and Commissioning Guidelines“

Fieldbus plug connectors

For the versions with fieldbus plug connector (M12 or 7/8"), the signal line can be connected without opening the housing.

Pin assignment of the M12 plug connector (PROFIBUS PA plug)

	Pin	Meaning
	1	Ground
	2	Signal +
	3	Signal -
	4	not connected

L00-FMxxxxxx-04-00-00-yy-016

Pin assignment of the 7/8" plug connector (FOUNDATION Fieldbus plug)

	Pin	Meaning
	1	Signal -
	2	Signal +
	3	not connected
	4	ground

L00-FMxxxxxx-04-00-00-yy-017

Supply voltage**HART, 2-wire**

The following values are the voltages across the terminals directly at the instrument:

Version		Current consumption	Terminal voltage minimum	Terminal voltage maximum
2-wire HART	Standard	4 mA	14 V	36 V
		20 mA	8 V	36 V
	EEx ia	4 mA	14 V	30 V
		20 mA	8 V	30 V
	EEx d	4 mA	14 V	30 V
		20 mA	11 V	30 V
Fixed current, adjustable, e.g. for solar power operation (measured value via HART)	Standard	11 mA	10 V	36 V
	EEx ia	11 mA	10 V	30 V
Fixed current for HART multidrop mode	Standard	4 mA ¹⁾	14 V	36 V
	EEx ia	4 mA ¹⁾	14 V	30 V

1) Start-up current 11 mA

HART, 4-wire, active

Version	Voltage	max. load
DC	10,5 ... 32 V	600 Ω
AC 50/60 Hz	90 ... 253 V	600 Ω

Terminals

Cable cross-section: 0.5 to 2.5 mm (20 to 14 AWG)

Cable entry

- Cable gland: M20x1.5 (recommended cable diameter 6 ... 10 mm)
- Cable entry G ½ or ½ NPT
- PROFIBUS-PA M12 plug
- Fieldbus Foundation 7/8" plug

Power consumption

Version	Power consumption
2-wire	51 mW ... 800 mW
4-wire AC	max. 4VA
4-wire DC; FMU 40/41	330 mW ... 830 mW
4-wire DC; FMU 42/43	600 mW ... 1 W

Current consumption (2-wire-instruments)

Communication	Current consumption
HART	3,6 ... 22 mA
PROFIBUS PA	max. 13 mA
Foundation Fieldbus	max. 15 mA

HART ripple	47...125 Hz: $V_{pp} = 200 \text{ mV}$ (measured at 500Ω)
Max. noise HART	500 Hz...10 kHz: $V_{rms} = 2.2 \text{ mV}$ (measured at 500Ω)
Galvanic isolation	With 4-wire devices, the evaluation electronics and mains voltage are galvanically isolated from each other.

Performance characteristics

Reaction time

The reaction time depends on the parameter settings. The minimum values are:

- 2-wire devices (FMU40/41/42): min. 2 s
- 2-wire devices (FMU43 - PROFIBUS PA or FOUNDATION Fieldbus): min. 2 s
- 2-wire devices (FMU44): min. 3 s
- 4-wire devices (FMU40/41/42/43/44): 0.5 s

Reference operating conditions

- Temperature = +20 °C
- Pressure = 1013 mbar abs.
- Humidity = 50 %
- Ideal reflective surface (e.g. calm, smooth fluid surface)
- No interference reflections within signal beam
- Set application parameters:
 - Tank shape = flat ceiling
 - Medium property = liquid
 - process conditions = calm surface

Measured value resolution

Sensor	Measured value resolution
FMU40	1 mm
FMU41	1 mm
FMU42	2 mm
FMU43	2 mm
FMU44	2 mm

Pulse frequency

- 2-wire devices (FMU40/41/42): max. 0.5 Hz
- 2-wire devices (FMU43 - PROFIBUS PA or FOUNDATION Fieldbus): max. 0.5 Hz
- 2-wire devices (FMU44): max. 0.3 Hz
- 4-wire devices (FMU40/41/42/43/44): max. 2 Hz

The exact values are dependent on the type of device and the parameter settings.

Measuring error

Typical specifications for reference operating conditions (include linearity, repeatability, and hysteresis):

Sensor	Measuring error
FMU40	± 2 mm or 0.2% of set measuring distance (empty calibration) ¹
FMU41	± 2 mm or 0,2% of set measuring distance (empty calibration) ¹
FMU42	± 4 mm or 0,2% of set measuring distance (empty calibration) ¹
FMU43	± 4 mm or 0,2% of set measuring distance (empty calibration) ¹
FMU44	± 4 mm or 0,2% of set measuring distance (empty calibration) ¹

¹whichever is greater

Influence of the vapor pressure

The vapor pressure at 20 °C (68 °F) gives a hint on the accuracy of the ultrasonic level measurement. If the vapor pressure at 20 °C (68 °F) is below 50 mbar, ultrasonic level measurement is possible with a very high accuracy. This is valid for water, aqueous solutions, water-solid-solutions, dilute acids (hydrochloric acid, sulfuric acid, ...), dilute bases (caustic soda, ...), oils, greases, slurries, pastes, ... High vapor pressures or outgassing media (ethanol, acetone, ammonia, ...) can influence the accuracy. If conditions like these are present, please contact the Endress+Hauser support.

Installation conditions

Installation variants FMU 40,
FMU 41

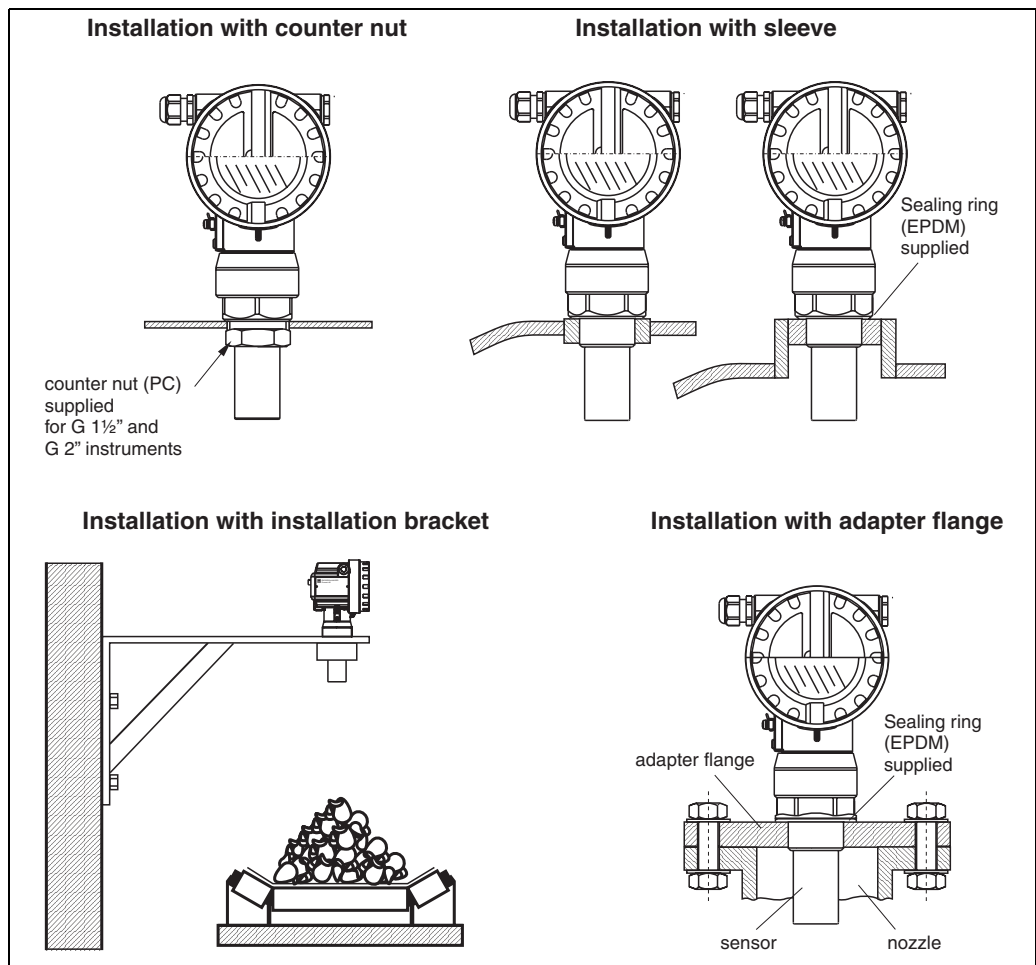

For installation bracket or adapter flange s. chapter "Accessories".

Installation variants FMU42,
FMU44

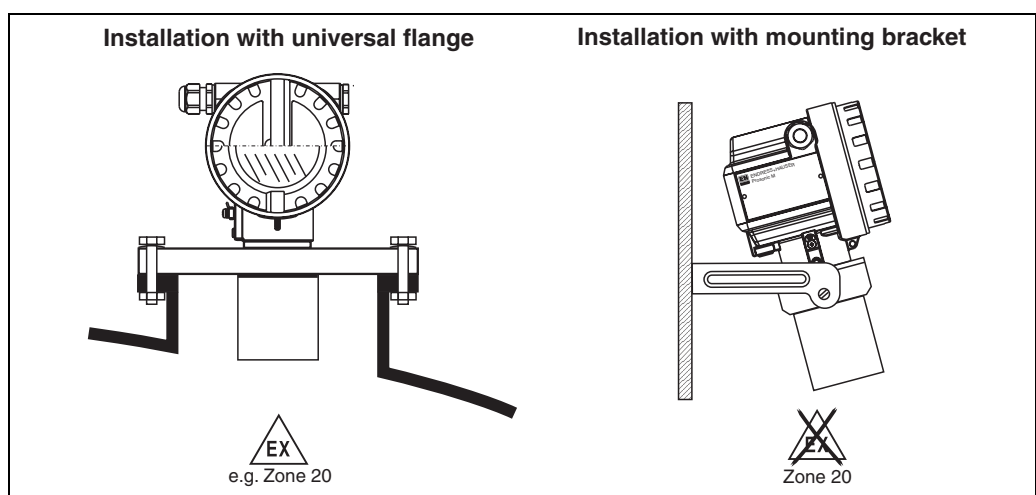

Installation variants FMU 43

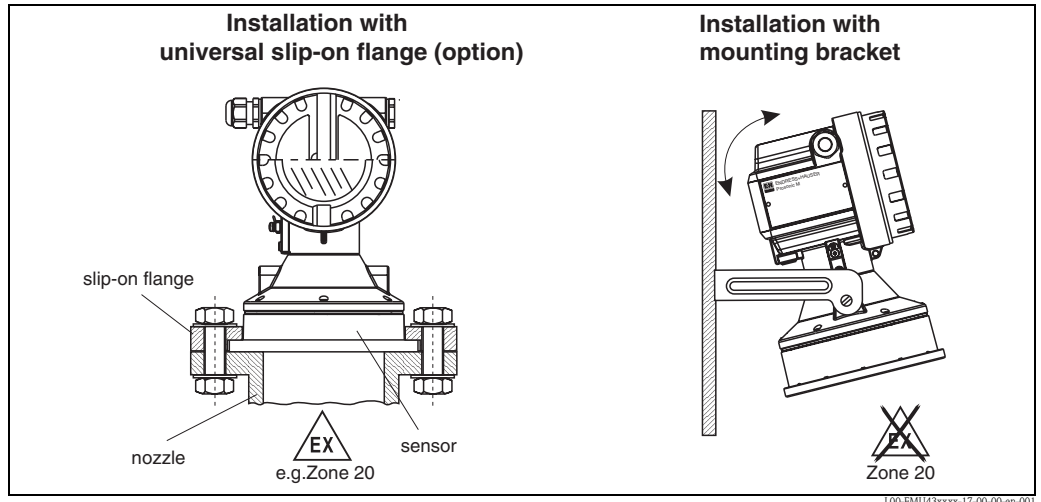

Installation conditions for level measurements

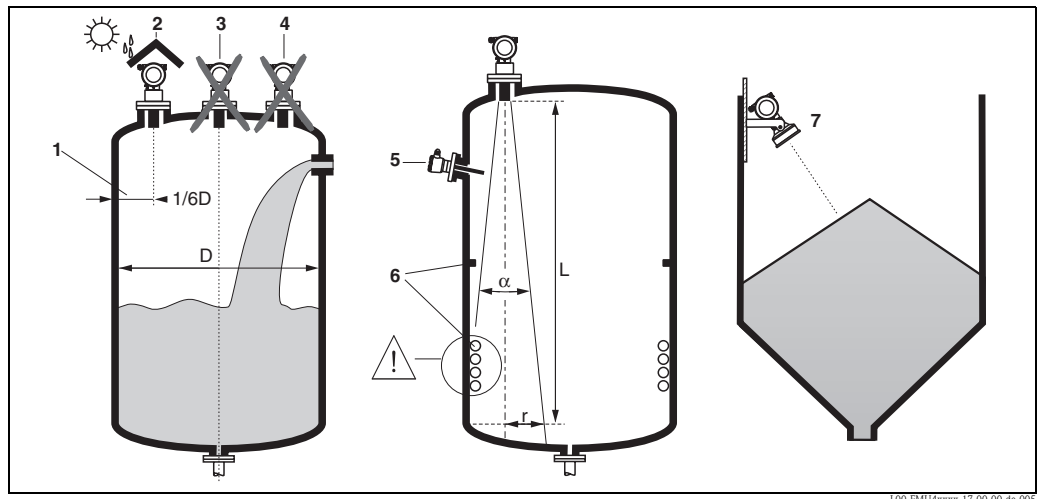

- Do not install the sensor in the middle of the tank (3). We recommend leaving a distance between the sensor and the tank wall (1) measuring 1/6 of the tank diameter.
- Use a protective cover, in order to protect the device from direct sun or rain (2).
- Avoid measurements through the filling curtain (4).
- Make sure that equipment (5) such as limit switches, temperature sensors, etc. are not located within the emitting angle α . In particular, symmetrical equipment (6) such as heating coils, baffles etc. can influence measurement.
- Align the sensor so that it is vertical to the product surface (7).
- Never install two ultrasonic measuring devices in a tank, as the two signals may affect each other.
- To estimate the detection range, use the 3 dB emitting angle α .

Sensor	α	L_{\max}	r_{\max}
FMU40	11°	5 m	0.48 m
FMU41	11°	8 m	0.77 m
FMU42	9°	10 m	0.79 m
FMU43	6°	15 m	0.79 m
FMU44	11°	20 m	1.93 m

Installation in narrow shafts

In narrow shafts with strong interference echoes, we recommend using an ultrasound guide pipe (e.g. PE or PVC wastewater pipe) with a minimum diameter of 100 mm. Make sure that the pipe is not soiled by accumulated dirt. If necessary, clean the pipe at regular intervals.

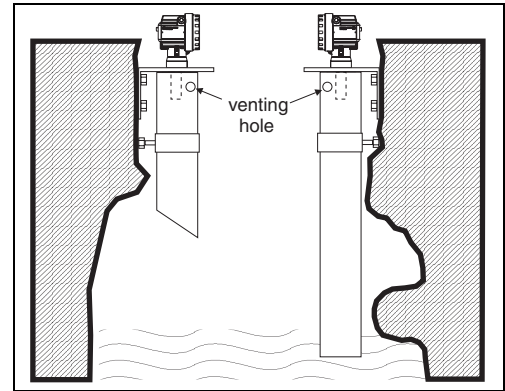

L00-FMU4xxxx-17-00-00-es-010

Installation conditions for flow measurements

- Install the Prosonic M at the inflow side, as close above the maximum water level H_{max} as possible (take into account the blocking distance BD).
- Position the Prosonic M in the middle of the channel or weir.
- Align the sensor membrane parallel to the water surface.
- Keep to the installation distance of the channel or weir.
- You can enter the "Flow to Level" linearisation curve ("Q/h curve") using ToF Tool or manually via the on-site display.

Example: Khafagi-Venturi flume

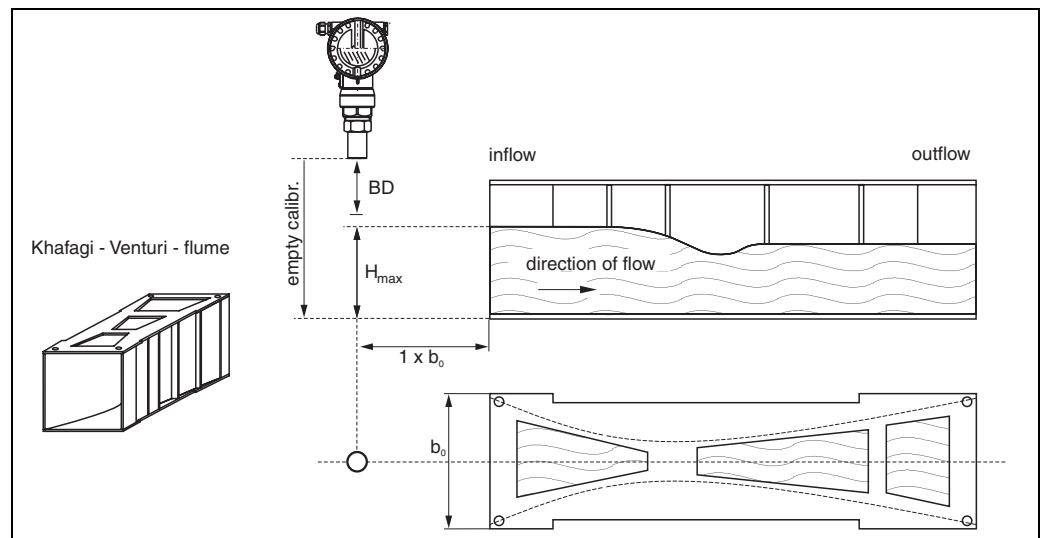

L00-FMU4xxxx-17-00-00-es-003

Example: Triangular weir

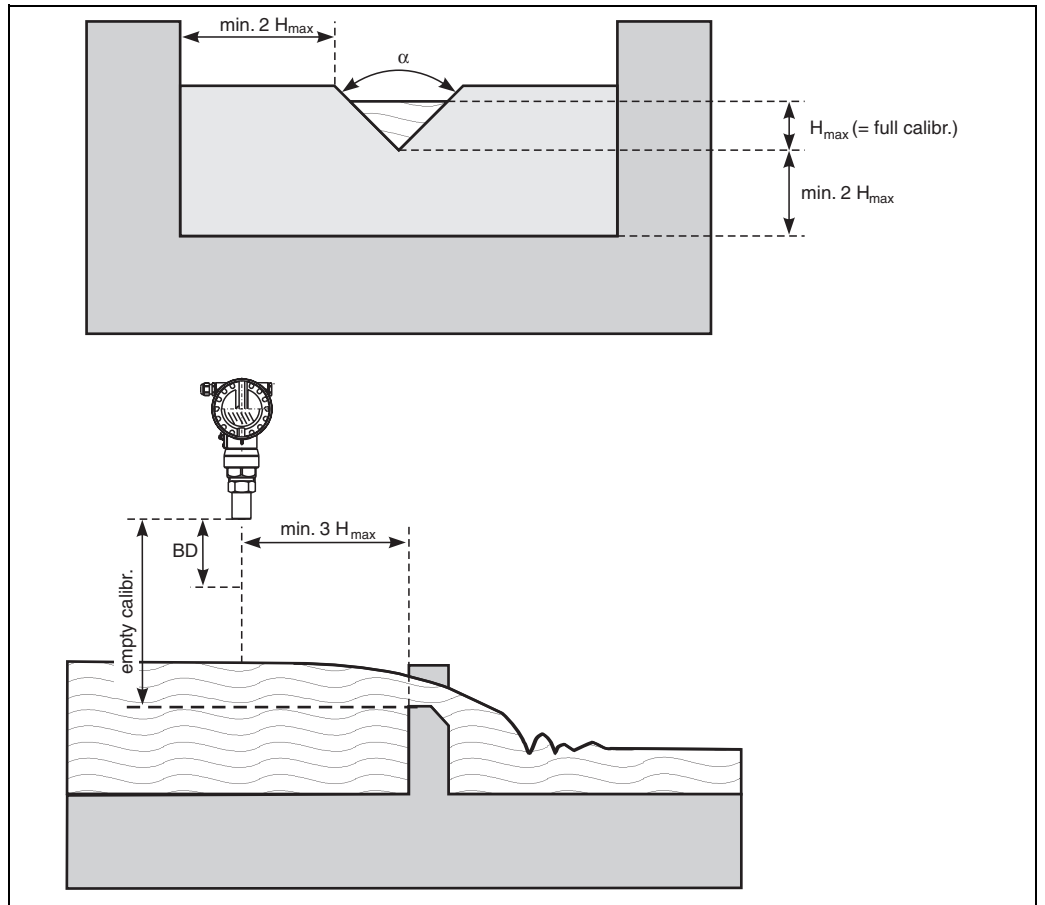

100-FMU4xxxx-17-00-00-en-012

Blocking distance, nozzle installation

Install the Prosonic M at a height so that the blocking distance BD is not undershot, even at maximum fill level. Use a pipe nozzle if you cannot maintain the blocking distance in any other way. The interior of the nozzle must be smooth and may not contain any edges or welded joints. In particular, there should be no burr on the inside of the tank side nozzle end. Note the specified limits for nozzle diameter and length. To minimise disturbing factors, we recommend an angled socket edge (ideally 45°).

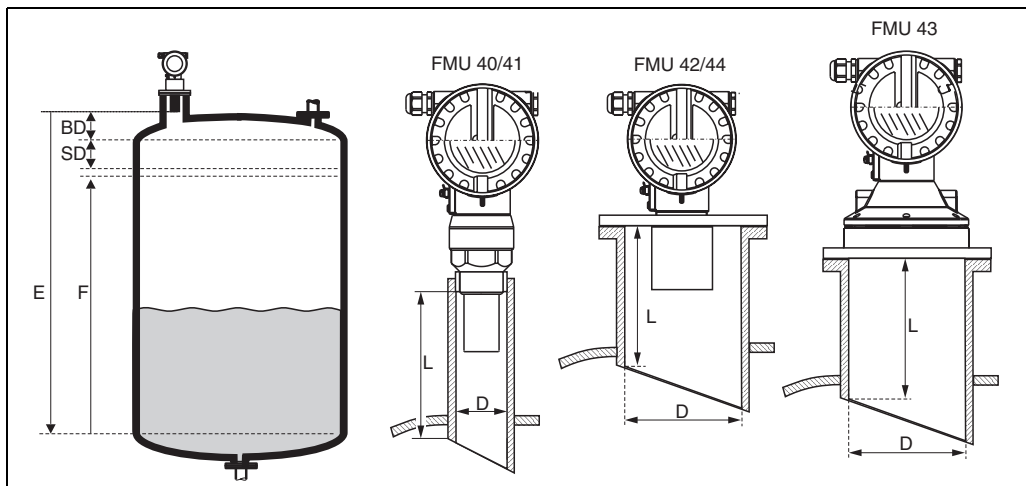

BD: blocking distance; **SD:** safety distance; **E:** empty calibration; **F:** full calibration (span); **D:** nozzle diameter; **L:** nozzle length

Nozzle diameter	Maximum nozzle length[mm]				
	FMU40	FMU41	FMU42	FMU43	FMU44
DN50/2"	80				
DN80/3"	240	240	250		
DN100/4"	300	300	300	300	
DN150/6"	400	400	400	300	400
DN200/8"	400	400	400	300	400
DN250/10"	400	400	400	300	400
DN300/12"	400	400	400	300	400
Emitting angle α	11°	11°	9°	6°	11°
Blocking distance [m]	0,25	0,35	0,4	0,6	0,5
Max. range [m] in liquids	5	8	10	15	20
Max. range [m] in solids	2	3,5	5	7	10



Caution!
If the blocking distance is undershot, it may cause device malfunction.



Note!
In order to notice if the level approaches the blocking distance, you can specify a safety distance (SD). If the level is within this safety distance, the Prosonic M outputs a warning or alarm message.

Ambient conditions

Ambient temperature	-40 °C ... +80 °C The functionality of the LC display becomes restricted at $T_u < -20$ °C and $T_u > +60$ °C. If the device is operated outdoors in strong sunlight, you should use a protective cover.
Storage temperature	-40 °C ... +80 °C
Resistance to alternating temperature cycles	to DIN EN 60068-2-14; Nb test : +80°C/-40°C, 1 K/min, 100cycles
Climate class	DIN EN 60068-2-38 (Test Z/AD) DIN/IEC 68 T2-30Db
Ingress protection	<ul style="list-style-type: none"> ■ With closed housing, tested according to <ul style="list-style-type: none"> – IP 68, NEMA 6P (24h at 1.83m under water surface) – IP 66, NEMA 4x ■ With open housing: IP 20, NEMA 1 (also ingress protection of the display) <div style="display: flex; align-items: center; margin-top: 10px;">  <p>Caution! Degree of protection IP 68 NEMA 6P applies for M12 PROFIBUS-PA plugs only when the PROFIBUS cable is plugged in.</p> </div>
Vibration resistance	DIN EN 60068-2-64 / IEC 68-2-64: 20...2000 Hz, 1 (m/s ²) ² /Hz; 3 x 100 min
Electromagnetic compatibility (EMC)	<ul style="list-style-type: none"> ■ Interference emission to EN 61326, Equipment Class B ■ Interference immunity to EN 61326, Appendix A (Industrial) and NAMUR Recommendation NE 21 (EMC). ■ A standard installation cable is sufficient if only the analogue signal is used. Use a screened cable when working with a superimposed communication signal (HART).

Process conditions

Process temperature	-40 °C ... +80 °C A temperature sensor is integrated in the sensor for correction of the temperature-dependent time-of-flight.
Process pressure	<ul style="list-style-type: none"> ■ FMU 40/41: 0.7 bar ... 3bar abs. ■ FMU 42/43/44: 0.7 bar ... 2.5bar abs.

Mechanical construction

Design; dimensions

FMU40, FMU41

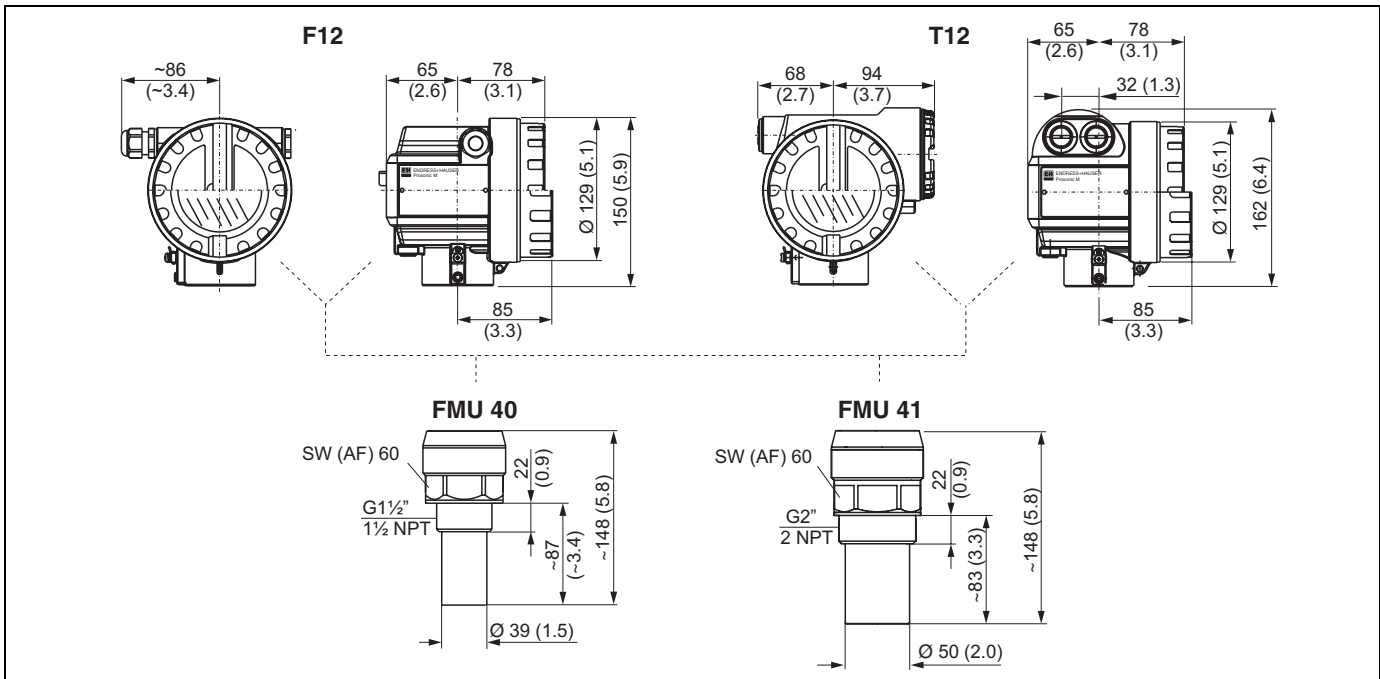

Dimensions in mm (inch)

FMU42, FMU44 with slip-on flange

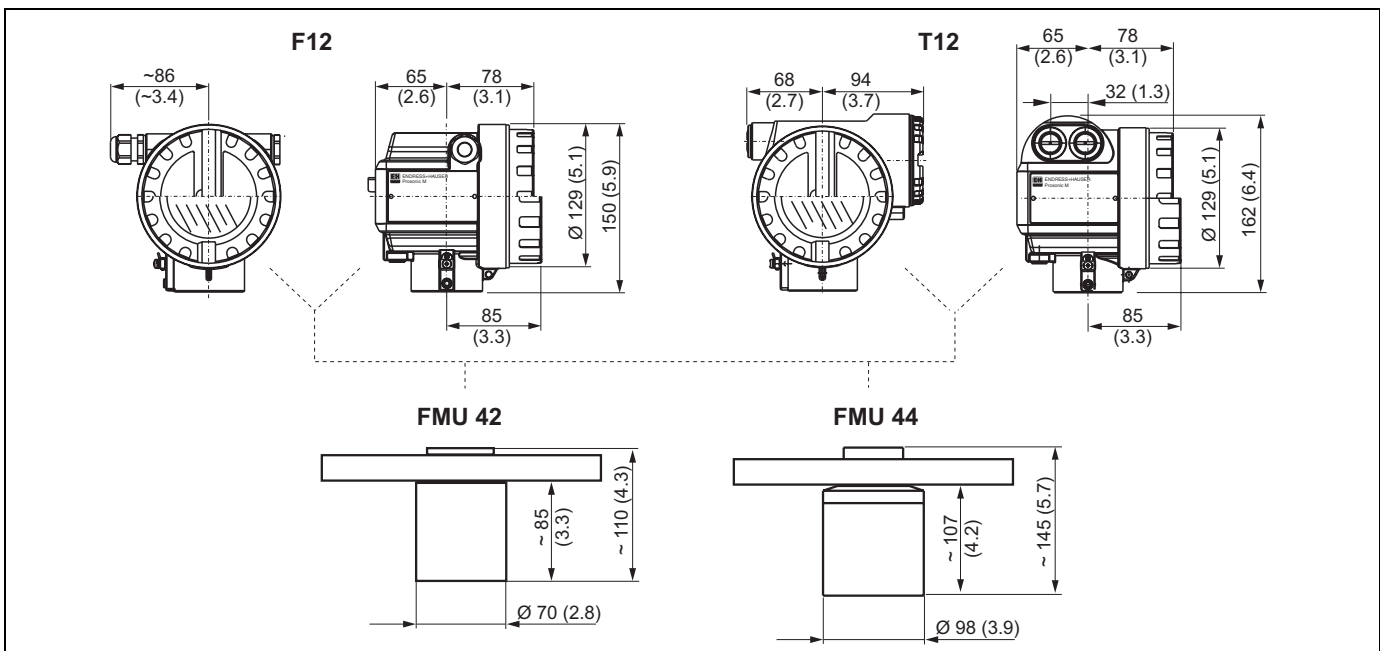

Dimensions in mm (inch)

FMU42, FMU44 with mounting bracket

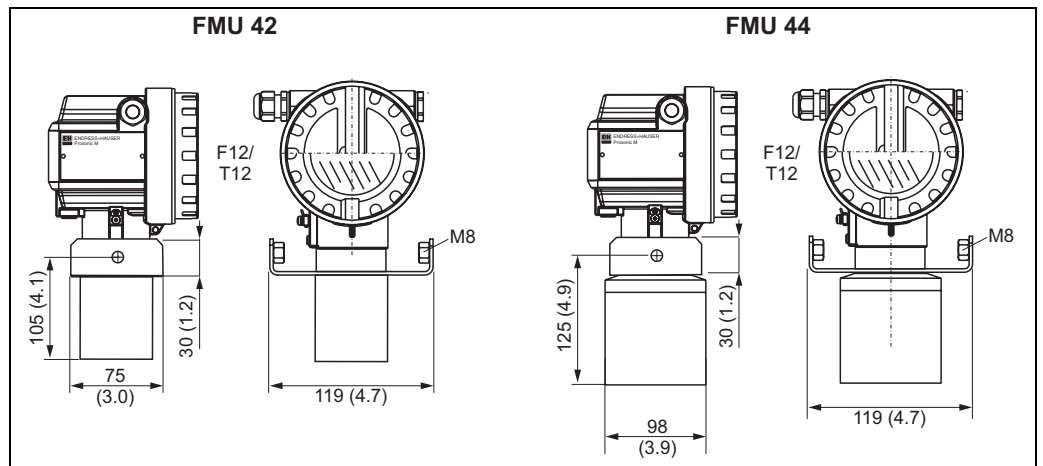

Dimensions in mm (inch)

FMU43

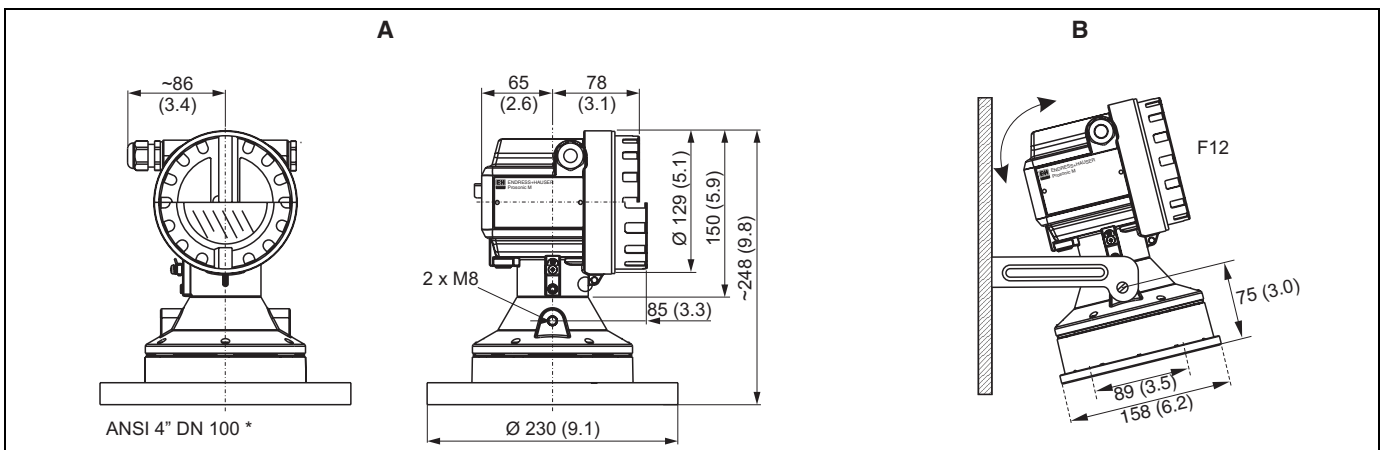

Dimensions in mm (inch);
A: with slip-on flange; B: with mounting bracket

Mounting bracket for FMU42, FMU43 and FMU44

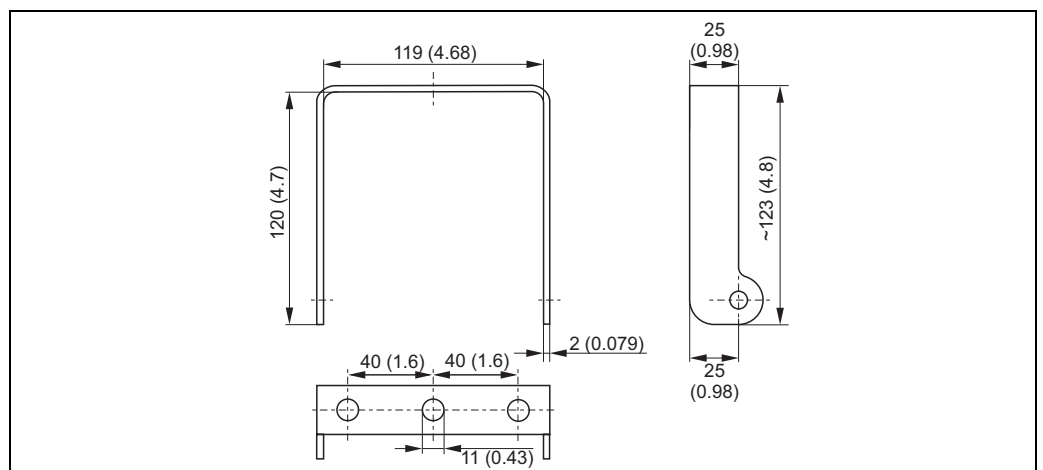

Dimensions in mm (inch)

Flanges for FMU42 and FMU44

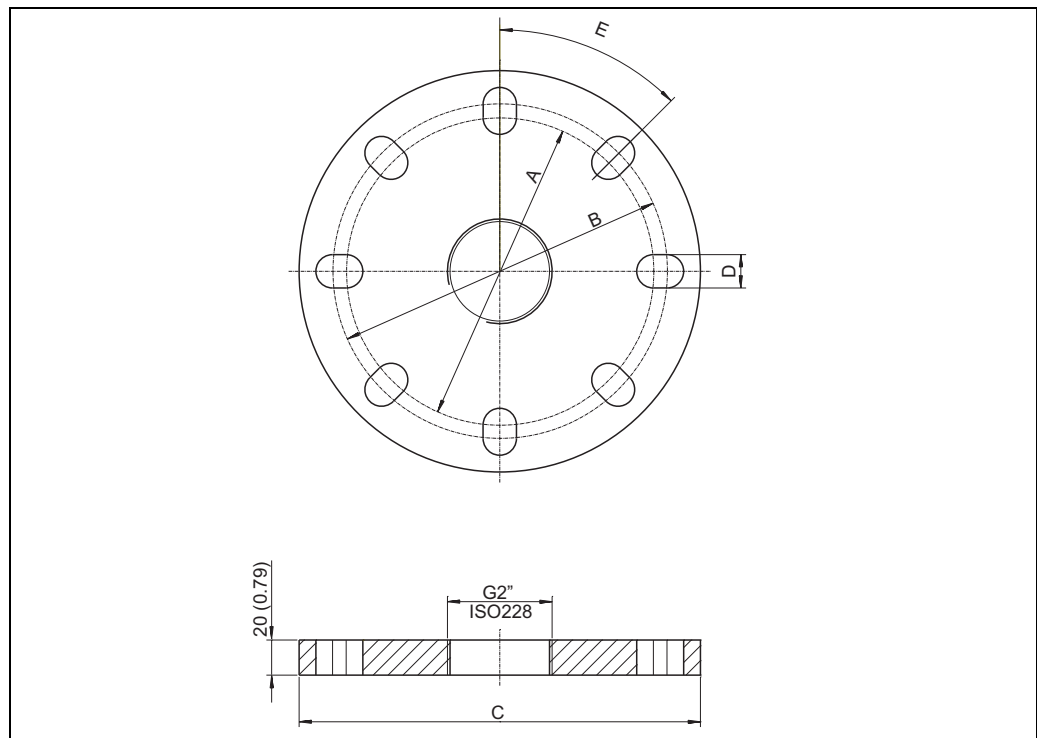

L00-FMU4xxxx-06-00-00-yy-011

suitable for	A	B	C	D	E	number of boreholes
3" 150lbs / DN80 PN16 / 10K 80	150 mm (5,91")	160 mm (6,30")	200 mm (7,87")	19 mm (0,75")	45°	8
4" 150 lbs / DN100 PN16 / 10K 100	175 mm (6,90")	190,5 mm (7,50")	228,6 mm (9,00")	19 mm (0,75")	45°	8
6" 150 lbs / DN150 PN16 / 10 K 150	240 mm (9,45")	241,3 mm (9,50")	285 mm (11,22")	23 mm (0,91")	45°	8
8" 150 lbs	298,5 mm (11,75")	298,5 mm (11,75")	342,9 mm (13,50")	22,5 mm (0,89")	45°	8
DN200 PN16 / 10 K 200	290 mm (11,42")	295 mm (11,61")	340 mm (13,39")	23 mm (0,91")	30°	12

Weight

Sensor	Weight
FMU40	approx. 2,5 kg
FMU41	approx. 2,6 kg
FMU42	approx. 3 kg
FMU43	approx. 3,5 kg
FMU44	approx. 4 kg

Housing design**Types of housings**

- F12 housing with sealed terminal compartment for standard or EEx ia applications
- T12 housing with separate terminal compartment and explosionproof encapsulation

Material

Aluminium, seawater resistant, powder-coated

Cover

- Aluminium, for version without on-site display
- Inspection glass for version with on-site display. This version cannot be supplied together with the ATEX II 1/2 D certificate.

**Process connection,
sealing material,
sensor material**

Sensor	Process connection	Material in contact with process
FMU40	<ul style="list-style-type: none"> ■ Thread G 1½" ■ Thread NPT 1½" - 11.5 	Sensor: PVDF Seal: EPDM
FMU41	<ul style="list-style-type: none"> ■ Thread 2" ■ Thread NPT 2" - 11,5 	Sensor: PVDF Seal: EPDM
FMU42	<ul style="list-style-type: none"> ■ Universal flange DN 80 PN16 / ANSI 3" 150 lbs / JIS 10K 80 ■ Universal flange DN 100 PN16 / ANSI 4" 150 lbs / JIS 10K 100 ■ Mounting bracket 	Sensor: PVDF Seal: VITON or EPDM Flange: PP, PVDF or SS 316L (1.4435 or 1.4404) ¹⁾
FMU43	<ul style="list-style-type: none"> ■ Universal flange DN 100 / ANSI 4" / JIS16K100 ■ Mounting bracket 	Sensor: UP and SS 316Ti Seal: EPDM Flange: PP or SS 316Ti
FMU44	<ul style="list-style-type: none"> ■ Universal flange DN 100 PN16 / ANSI 4" 150 lbs / JIS 10K 100 ■ Universal flange DN 150 PN16 / ANSI 6" 150 lbs / JIS 10K 150 ■ Universal flange DN200 PN16 / JIS 10K 200 ■ Flange ANSI 8" 150 lbs ■ Mounting bracket 	Sensor PVDF Seal: VITON or EPDM Flange: PP, PVDF or SS 316L (1.4435 or 1.4404) ¹⁾

1) Endress+Hauser supplies DIN/EN flanges made of stainless steel AISI 316L with the material number 1.4435 or 1.4404. With regard to their temperature stability properties, the materials 1.4435 and 1.4404 are grouped under 13E0 in EN 1092-1 Tab. 18. The chemical composition of the two materials can be identical.

Human interface

Display and operating elements

The LCD module VU 331 for display and operation is located beneath the housing cover. The measured value is legible through the glass in the cover. Open the cover to operate the device.

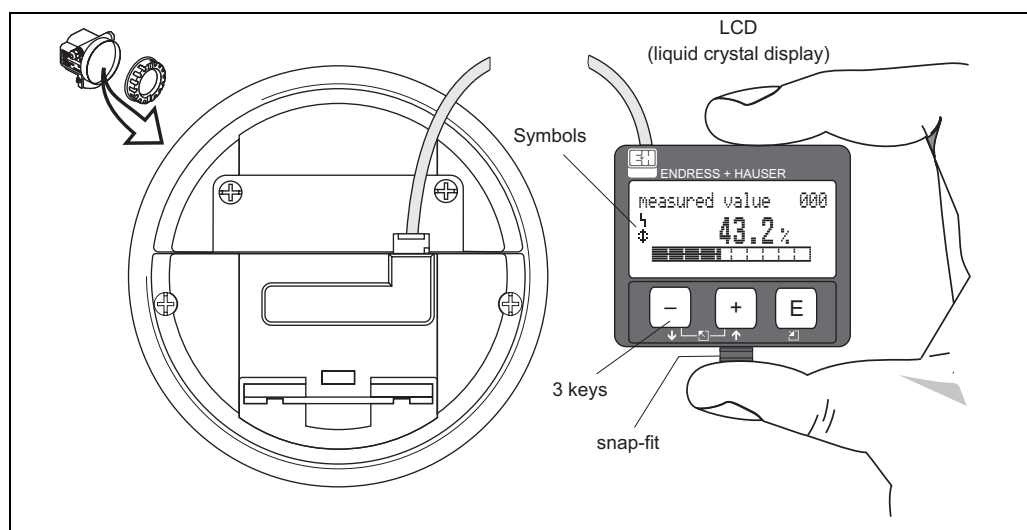

100-FMxxxxx-07-00-00-en-001

Symbol in display				
Meaning	Alarm	Warning	Communication	Security Locking

Function of the keys

Key(s)	Meaning
	Navigate upwards in the selection list Edit numeric value within a function
	Navigate downwards in the selection list Edit numeric value within a function
	Navigate to the left within a function group
	Navigate to the right within a function group, confirmation.
	Contrast settings of the LCD
	Hardware lock / unlock After a hardware lock, an operation of the instrument via display or communication is not possible! The hardware can only be unlocked via the display. An unlock parameter must be entered to do so.

On-site operation

Operation with VU 331

The LC-Display VU 331 allows configuration via 3 keys directly at the instrument. All device functions can be set through a menu system. The menu consists of function groups and functions. Within a function, application parameters can be read or adjusted. The user is guided through a complete configuration procedure.

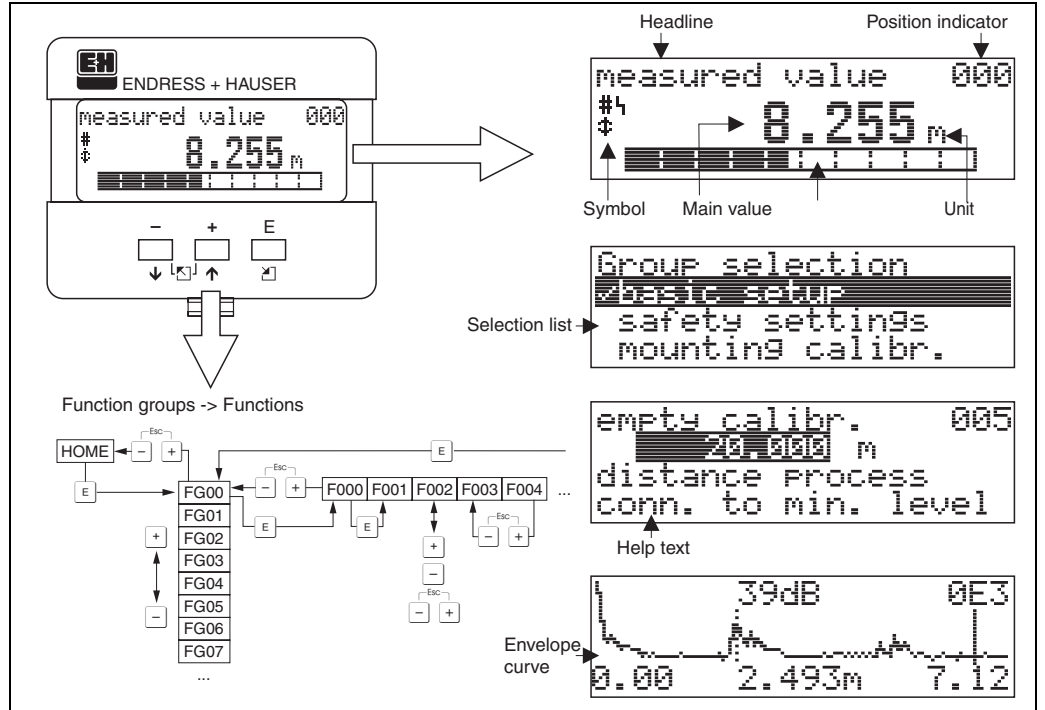

L00-FMU14xxxx-07-00-00-en-004

Operation with the handheld terminal DXR 375

On devices with HART communication, you can also access the menu using the handheld terminal DXR 375.

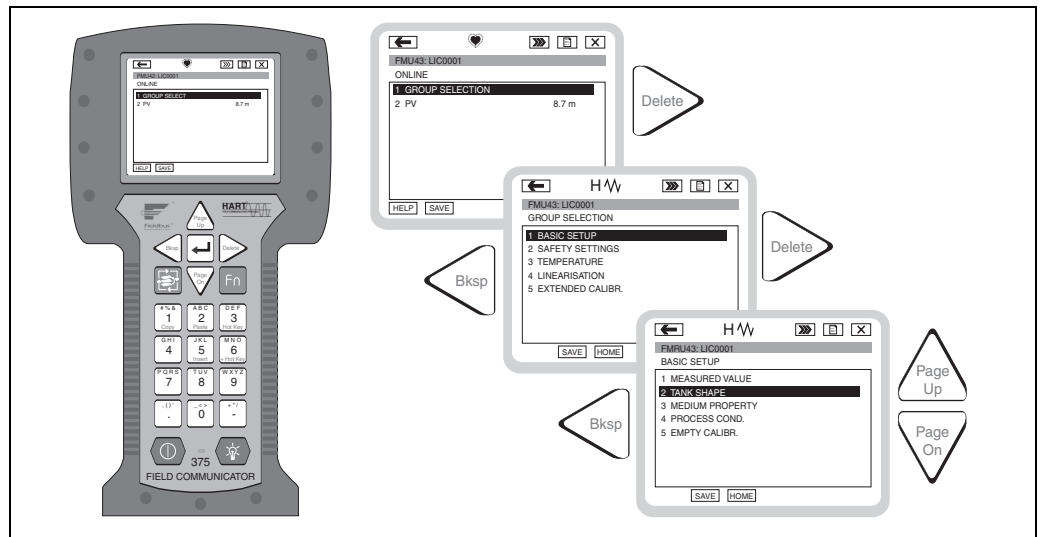

L00-FMU14xxxx-07-00-00-de-005

Remote operation

Operation with ToF Tool

The ToF Tool is a graphical operation software for instruments from Endress+Hauser. It is used to support commissioning, securing of data, signal analysis and documentation of the instruments. It is compatible with the following operating systems: WinNT4.0, Win2000 and WinXP.

The ToF Tool supports the following functions:

- Online configuration of transmitters
- Signal analysis via envelope curve
- Linearisation table (graphically supported creation, editing, importing and exporting)
- Loading and saving of instrument data (Upload/Download)
- Documentation of measuring point



Note!

Further information you may find on the CD-ROM, which is enclosed to the instrument.

Connection options

- HART with Commubox FXA 191 (available as accessory)
- PROFIBUS PA
- Service-interface with adapter FXA 193 (available as accessory)

Menu-guided commissioning:

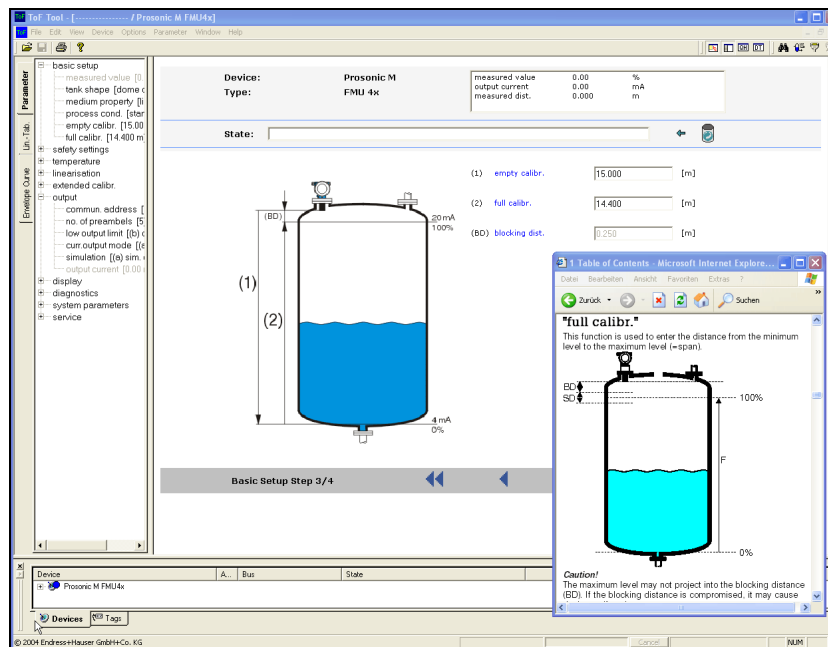

100-FMU4xxxx-19-00-00-en-003

Signal analysis via envelope curve:

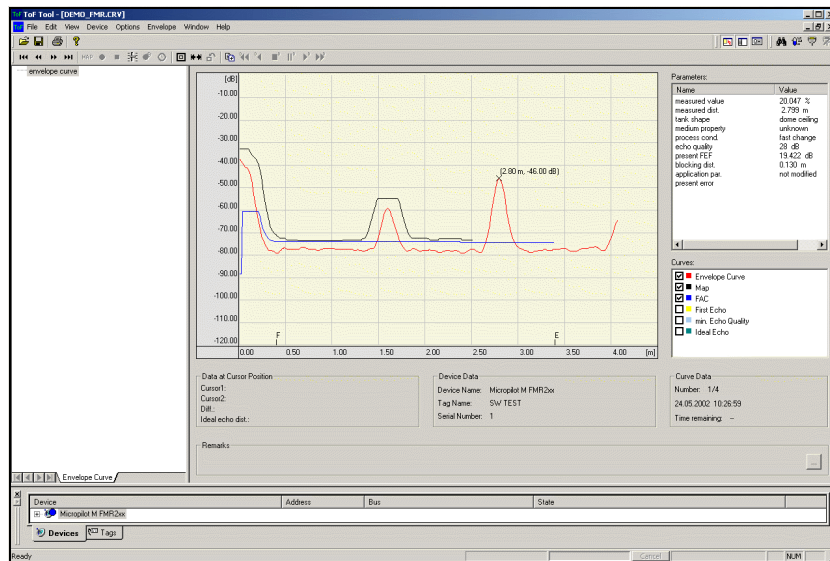

L00-FMU14xxxx-19-00-00-en-004

Operation with FieldCare

FieldCare is Endress+Hauser's FDT based Plant Asset Management Tool. It can configure all intelligent field devices in your plant and supports you in managing them. By using status information, it also provides a simple but effective means of checking their health.

- Supports Ethernet, HART, PROFIBUS, FOUNDATION Fieldbus etc.
- Operates all Endress+Hauser devices
- Operates all third-party actuators, I/O systems and sensors supporting the FDT standard
- Ensures full functionality for all devices with DTMs
- Offers generic profile operation for any third-party fieldbus device that does not have a vendor DTM

Operation with Commuwin II (for communication variants HART or PROFIBUS-PA)

Commuwin II is an operating software with graphical support (MS Windows) for intelligent transmitters with the communication protocols Rackbus, Rackbus RS-485, HART and PROFIBUS-PA.

Commuwin II supports the following functions:

- Online configuration of transmitters
- Loading and saving of instrument data (Upload/Download)
- Orderly visualisation of measured values and limit values
- Display and recording of measured values with a line recorder

It is not possible to display envelope curves with Commuwin II. To display them, please use the ToF Tool program supplied.

Connections:

- HART with Commubox FXA 191 (available as accessory)
- PROFIBUS PA

Operation with NI-FBUS Configurator (only Foundation Fieldbus)

The NI-FBUS Configurator is an easy-to-use graphical environment for creating linkages, loops, and a schedule based on the fieldbus concepts.

You can use the NI-FBUS Configurator to configure a fieldbus network as follows:

- Set block and device tags
- Set device addresses
- Create and edit function block control strategies (function block applications)
- Configure vendor-defined function and transducer blocks
- Create and edit schedules
- Read and write to function block control strategies (function block applications)
- Invoke Device Description (DD) methods
- Display DD menus
- Download a configuration
- Verify a configuration and compare it to a saved configuration
- Monitor a downloaded configuration
- Replace devices
- Save and print a configuration

Certificates and Approvals

CE mark	The measuring system meets the legal requirements of the EC-guidelines. Endress+Hauser confirms the instrument passing the required tests by attaching the CE-mark.
Ex approval	The available certificates are listed in the ordering information. Note the associated safety instructions (XA) and control or installation drawings (ZD).
External standards and guidelines	<p>EN 60529 Protection class of housing (IP-code)</p> <p>EN 61326 Electromagnetic compatibility (EMC requirements)</p> <p>NAMUR Standards committee for measurement and control in the chemical industry</p>

Ordering information

Product structure FMU 40

Certificates	
A	Variant for non-hazardous area
E	NEPSI Ex nA II T6
G	ATEX II 3G EEx nA II T6
I	NEPSI Ex ia IIC T6
J	NEPSI Ex d(ia) IIC T6
K	TIIS Ex ia II C T6
N	CSA General Purpose
Q	NEPSI DIP
S	FM IS Cl. I,II,III Div. 1 Gr. A-G / NI Cl. I Div. 2
T	FM XP Cl. I,II,III Div. 1 Gr. A-G
U	CSA IS Cl. I,II,III Div. 1 Gr. A-G / NI Cl. I Div. 2
V	CSA XP Cl. I,II,III Div. 1 Gr. A-G
1	ATEX II 1/2 G or II 2 G; EEX ia IIC T6
2	ATEX II 1/2D, Alu blind cover
4	ATEX II 1/2 G or II 2 G; EEX d [ia] IIC T6
5	ATEX II 1/3D
Y	Special certificate
Process connection	
R	G 1½" thread ISO 228
N	NPT 1½" - 11,5 thread
Y	Special version
Power supply/communication	
B	2 wire, 4...20mA-loop/HART
H	4 wire, 10,5...32VDC / 4-20mA HART
G	4 wire, 90...253VAC / 4-20mA HART
D	2 wire, PROFIBUS PA
F	2 wire, Foundation Fieldbus
Y	Special version
Display / on-site operation	
1	Without LC display
2	With LC display VU 331 incl. on-site operation
3	Prepared for remote display FHX 40
9	Special version
Housing	
A	Aluminium F12 housing coated to IP 68
C	Aluminium T12 housing coated to IP 68; with separate terminal compartment
D	Aluminium T12 housing coated to IP 68; with separate terminal compartment; with overvoltage protection
9	Special version
Screw union/entry	
2	M20x1.5 screw union
3	G 1/2" entry
4	NPT 1/2" entry
5	M12 PROFIBUS-PA plug-in connector
6	7/8" FF plug
9	Special version
FMU 40 -	Product designation

Product structure FMU 41

Certificates	
A	Variant for non-hazardous area
E	NEPSI Ex nA II T6
G	ATEX II 3G EEx nA II T6
I	NEPSI Ex ia IIC T6
J	NEPSI Ex d(Ia) IIC T6
K	TIIS Ex ia II C T6
N	CSA General Purpose
Q	NEPSI DIP
S	FM IS Cl. I,II,III Div. 1 Gr. A-G / NI Cl. I Div. 2
T	FM XP Cl. I,II,III Div. 1 Gr. A-G
U	CSA IS Cl. I,II,III Div. 1 Gr. A-G / NI Cl. I Div. 2
V	CSA XP Cl. I,II,III Div. 1 Gr. A-G
1	ATEX II 1/2 G or II 2 G; EEX ia IIC T6
2	ATEX II 1/2D, Alu blind cover
4	ATEX II 1/2 G or II 2 G; EEX d [ia] IIC T6
5	ATEX II 1/3D
Y	Special certificate
Process connection	
R	G 2" thread ISO 228
N	NPT 2" - 11,5 thread
Y	Special version
Power supply/communication	
B	2 wire, 4...20mA-loop/HART
H	4 wire, 10,5...32VDC / 4-20mA HART
G	4 wire, 90...253VAC / 4-20mA HART
D	2 wire, PROFIBUS PA
F	2 wire, Foundation Fieldbus
Y	Special version
Display / on-site operation	
1	Without LC display
2	With LC display VU 331 incl. on-site operation
3	Prepared for remote display FHX 40
9	Special version
Housing	
A	Aluminium F12 housing coated to IP 68
C	Aluminium T12 housing coated to IP 68 with separate terminal compartment
D	Aluminium T12 housing coated to IP 68; with separate terminal compartment; with overvoltage protection
9	Special version
Screw union/entry	
2	M20x1.5 screw union
3	G 1/2" entry
4	NPT 1/2" entry
5	M12 PROFIBUS-PA plug-in connector
6	7/8" FF plug
9	Special version
FMU 41 -	Product designation

Product structure FMU 42

Certificates	
A	Variant for non-hazardous area
E	NEPSI Ex nA II T6
G	ATEX II 3G EEx nA II T6
I	NEPSI Ex ia IIC T6
J	NEPSI Ex d (Ia) IIC T6
K	TIIS Ex ia II C T6 (in preparation)
N	CSA General Purpose
Q	NEPSI DIP
S	FM IS Cl. I,II,III Div. 1 Gr. A-G / NI Cl. I Div. 2
T	FM XP Cl. I,II,III Div. 1 Gr. A-G
U	CSA IS Cl. I,II,III Div. 1 Gr. A-G / NI Cl. I Div. 2
V	CSA XP Cl. I,II,III Div. 1 Gr. A-G
1	ATEX II 1/2 G EEX ia IIC T6
2	ATEX II 1/2 D, Alu bond cover
4	ATEX II 1/2 G EEX d [ia] IIC T6
5	ATEX II 1/3D
Y	Special certificate
Process connection	
M	Mounting bracket FAU20
P	UNI flange 3"/DN80/80, PP, max. 2.5bar abs./ 36psia suitable for 3" 150lbs / DN80 PN16 / 10K 80
Q	UNI flange 3"/DN80/80, PVDF, max. 2.5bar abs./ 36psia suitable for 3" 150lbs / DN80 PN16 / 10K 80
S	UNI flange 3"/DN80/80, 316L, max. 2.5bar abs./ 36psia suitable for 3" 150lbs / DN80 PN16 / 10K 80
T	UNI flange 4"/DN100/100, PP, max. 2.5bar abs./ 36psia suitable for 4" 150lbs / DN100 PN16 / 10K100
U	UNI flange 4"/DN100/100, PVDF, max. 2.5bar abs./ 36psia suitable for 4" 150lbs / DN100 PN16 / 10K100
V	UNI flange 4"/DN100/100, 316L, max. 2.5bar abs./ 36psia suitable for 4" 150lbs / DN100 PN16 / 10K100
Y	Special version
Power supply/communication	
B	2 wire, 4...20mA-loop/HART
H	4 wire, 10,5...32VDC / 4-20mA HART
G	4 wire, 90...253VAC / 4-20mA HART
D	2 wire, PROFIBUS PA
F	2 wire, Foundation Fieldbus
Y	Special version
Display / on-site operation	
1	Without LC display
2	With LC display VU 331 incl. on-site operation
3	Prepared for remote display FHX 40
9	Special version
Housing	
A	Aluminium F12 housing coated to IP 68
C	Aluminium T12 housing coated to IP 68, with separate terminal compartment
D	Aluminium T 12 housing coated to IP 68, with separate terminal compartment; with overvoltage protection
Y	Special version
Gland/Entry	
2	M20x1.5 gland
3	G 1/2" entry
4	NPT 1/2" entry
5	M12 PROFIBUS-PA plug
6	7/8" FF plug
9	Special version
Sealing Sensor/Flange	
2	VITON flat sealing

										Sealing Sensor/Flange	
										3	EPDM flat sealing
										9	special version
										Additional options	
										A	Additional options not selected
FMU 42 -											Product designation

Product structure FMU 43

		Certificates	
	A	Variant for non-hazardous area	
	M	FM DIP Class II, III, Div. 1, Gr. E,F,G NI	
	N	CSA General Purpose	
	P	CSA DIP, Class II, III, Div. 1, Gr. E,F,G NI	
	Q	NEPSI DIP	
	2	ATEX II 1/2 D or II 2 D, Aluminium Deckel	
	5	ATEX II 1/3 D or II 3 D, Sichtdeckel	
	Y	Special version	
		Process connection/material	
	P	Flange DN 100/ANSI 4"/JIS 16K100, PP (universal slip-on flange included)	
	S	Flange DN 100/ANSI 4"/JIS 16K100, SS 316TI (universal slip-on flange included)	
	K	Without slip-on flange/without mounting bracket (customer mounting equipment)	
	M	With mounting bracket	
	Y	Special version	
		Power supply/communication	
	H	4 wire, 10,5...32VDC / 4-20mA HART	
	G	4 wire, 90...253VAC / 4-20mA HART	
	D	2 wire, PROFIBUS PA	
	F	2 wire, Foundation Fieldbus	
	Y	Special version	
		Display / on-site operation	
	1	Without LC display	
	2	With LC display VU 331 incl. on-site operation	
	3	Prepared for remote display FHX 40	
	9	Special version	
		Housing	
	A	Aluminium F12 housing coated to IP 68	
	9	Special version	
		Screw union/entry	
	2	M20x1.5 screw union	
	3	G 1/2" entry	
	4	NPT 1/2" entry	
	5	M12 PROFIBUS-PA plug-in connector	
	6	7/8" FF plug	
	9	Special version	
FMU 43 -			Product designation

Product structure FMU 44

		Approval	
	A		Non-hazardous area
	1		ATEX II 1/2G EEx ia IIC T6 (in preparation)
	4		ATEX II 1/2G EEx d (ia) IIC T6 (in preparation)
	G		ATEX II 3 G EEx nA II T6 (in preparation)
	2		ATEX II 1/2 D, Alu blind cover (in preparation)
	5		ATEX II 1/3 D
	S		FM IS Cl.I,II,III Div.1 Gr.A-G, NI Cl.I Div.2 (in preparation)
	T		FM XP Cl.I,II,III Div.1 Gr.A-G (in preparation)
	N		CSA General Purpose
	U		CSA IS Cl.I,II,III Div.1 Gr.A-G, NI Cl.I Div.2
	V		CSA XP Cl.I,II,III Div.1 Gr.A-G
	K		TIIS EEx ia IIC T6 (in preparation)
	I		NEPSI Ex ia IIC T6 (in preparation)
	J		NEPSI Ex d(ia) IIC T6 (in preparation)
	E		NEPSI Ex nA II T6 (in preparation)
	Q		NEPSI DIP (in preparation)
	Y		Special version, to be specified
		Process connection	
	A		8" 150lbs FF, 316L, max 2.5bar abs./36psia
	E		UNI flange 6"/DN150/150, PP, max 2.5bar abs./ 36psia, suitable for 6" 150lbs / DN150 PN16 / 10K 150
	F		UNI flange 6"/DN150/150, PVDF, max 2.5bar abs./36psia, suitable for 6" 150lbs /DN150 PN16 / 10K 150
	G		UNI flange 6"/DN150/150, 316L, max 2.5bar abs. 36psia, suitable for 6" 150lbs / DN150 PN16 / 10K 150
	H		UNI flange DN200/200, PP, max 2.5bar abs./ 36 psia, suitable for DN200 PN16 / 10K 200
	J		UNI flange DN200/200, PVDF, max 2.5bar abs./ 36psia, suitable for DN200 PN16 / 10K 200
	K		UNI flange DN200/200, 316L, max 2.5bar abs./ 36psia, suitable for DN200 PN16 / 10K 200
	L		8" 150lbs FF, PP, max 2.5bar abs./ 36psia
	M		Mounting bracket FAU20
	N		8" 150lbs FF, PVDF, max 2.5bar abs./ 36psia
	T		UNI flange 4"/DN100/100, PP, max 2.5bar abs./ 36psia, suitable for 4" 150lbs / DN100 PN16 / 10K 100
	U		UNI flange 4"/DN100/100, PVDF, max. 2.5bar abs./ 36 psia, suitable for 4" 150lbs / DN100 PN16 / 10K 100
	V		UNI flange 4"/DN100/100, 316L, max 2.5bar abs./ 36psia, suitable for 4" 150lbs / DN100 PN16 / 10K 100
	Y		Special version, to be specified
		Power supply; Output	
	B		2-wire; 4-20mA HART
	D		2-wire; PROFIBUS PA
	F		2-wire; FOUNDATION Fieldbus
	G		4-wire 90-250VAC; 4-20mA HART
	H		4-wire 10.5-32VDC; 4-20mA HART
	Y		Special version, to be specified
		Operation	
	1		w/o display, via communication
	2		4-line display VU331, Envelope curve display on site
	3		Prepared for FHX40, Remote display (accessory)
	9		Special version, to be specified
FMU 44 -			product designation, part 1

Housing									
							A	F12 Alu, coated IP68 NEMA6P	
							C	T12 Alu, coated IP68 NEMA6P, Separate conn. compartment	
							D	T12 Alu, coated IP68 NEMA6P + OVP, Sep. conn. compartment, OVP = overvoltage protection	
							9	Special version, to be specified	
Cable entry									
							2	Gland M20 (EEx d > thread M20)	
							3	Thread G1/2	
							4	Thread NPT 1/2	
							5	Plug M12	
							6	Plug 7/8"	
							9	Special version, to be specified	
Process Sealing Sensor/ Flange									
							2	Viton	
							3	EPDM	
							9	Special version, to be specified	
Additional option									
							A	Basic version	
							Y	Special version, to be specified	
FMU 44 -								complete product designation	

Scope of delivery

- Instrument according to the version ordered
- "ToF Tool FieldTool Package (2 CD-ROMs: Program CD-ROM, Utility CD-ROM)
- Operating manual according to the communication version
- for certified instrument versions: Safety Instructions, Control- or Installation drawings
- for FMU 40 *R**** and FMU 41 *R****: counter nut (PC)
- for FMU 40/41: sealing ring (EPDM)
- for gland M20x1.5:
 - 1 cable gland for 2-wire instruments
 - 2 cable glands for 4-wire instruments
 The cable glands are mounted on delivery.

Accessories

Weather protection cover

A Weather protection cover made of stainless steel is recommended for outdoor mounting (order code: 543199-0001). The shipment includes the protective cover and tension clamp.

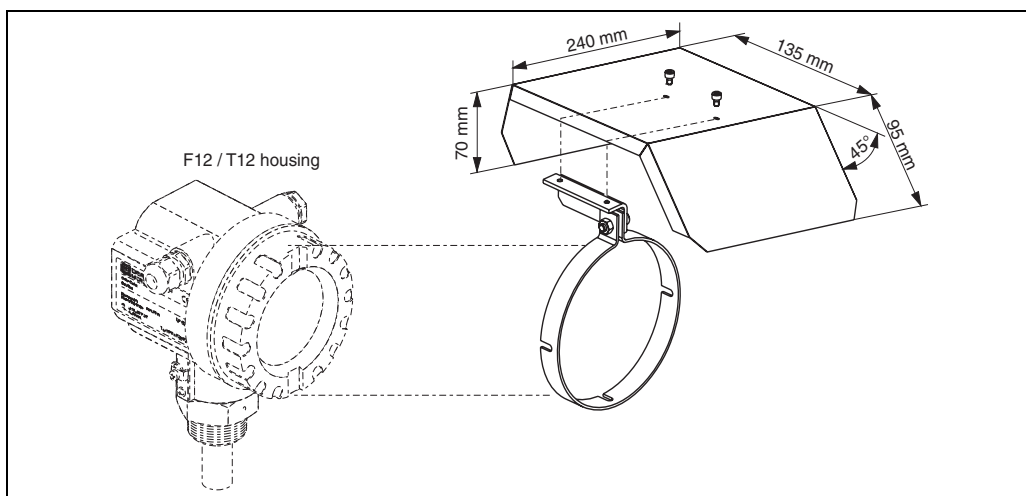

L00-FMR2xxxx-00-00-06-es-001

Installation bracket for FMU 40/41

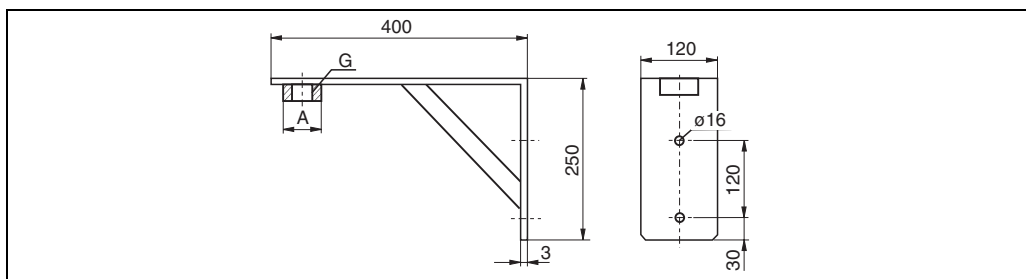

L00-FMU4x-00-00-00-de-001

- for FMU 40, G1½: Order No. 942669-0000
- for FMU 41, G2: Order No. 942669-0001

suited for NPT 1½" and 2" as well

Adapter flange

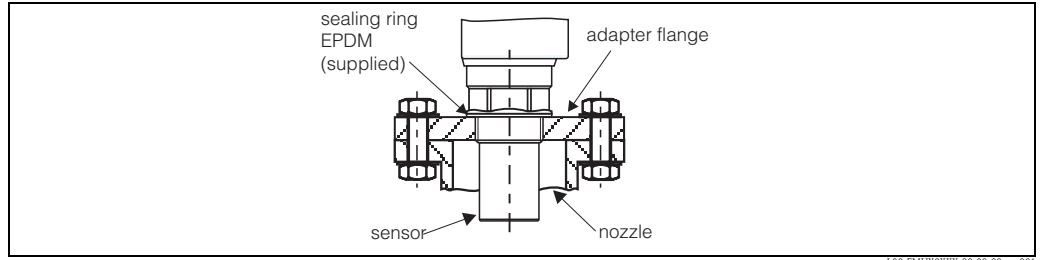

L00-FMUX3XXX-00-00-00-en-001

Version with metrical thread (FAU 70 E)

Process Connection	
12	DN 50 PN 16 A, flange EN1092-1 (DIN2527 B)
14	DN 80 PN 16 A, flange EN1092-1 (DIN2527 B)
15	DN 100 PN 16, A, flange EN1092-1 (DIN2527 B)
Sensor Connection	
3	Thread ISO228 G1-1/2
4	Thread ISO228 G2
Flange Material	
2	316L
7	Polypropylene
FAU 70 E	Product designation

Version with conical thread(FAU 70 A)

Process Connection	
22	2" 150lbs FF, flange ANSI B16.5
24	3" 150lbs FF, flange ANSI B16.5
25	4" 150lbs FF, flange ANSI B16.5
Sensor Connection	
5	Thread NPT1-1/2
6	Thread NPT2
Flange Material	
2	316L
7	Polypropylene
FAU 70 A	Product designation

Cantilever

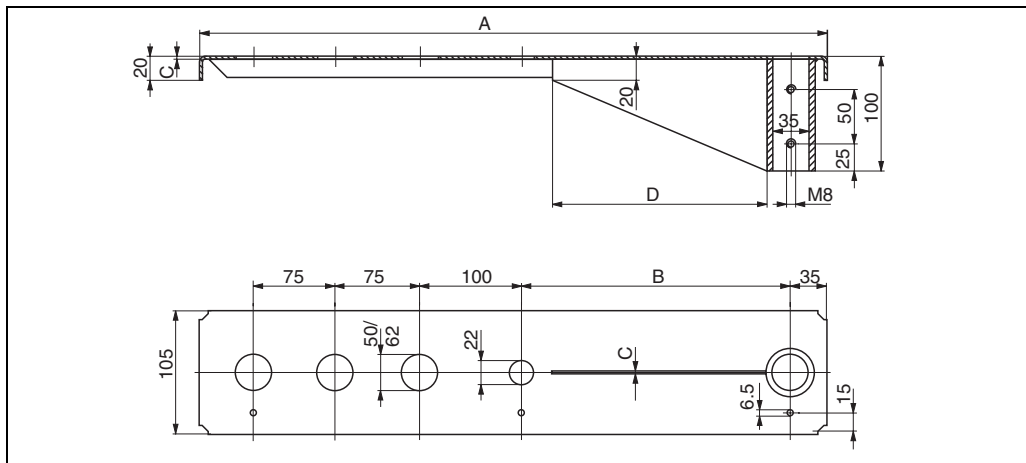

A	B	C	D	for Sensor	Material	Order Code
585 mm	250 mm	2 mm	200 mm	FMU 40	316Ti/1.4571	52014132
					galv. steel	52014131
				FMU 41	316Ti/1.4571	52014136
					galv. steel	52014135
1085 mm	750 mm	3 mm	300 mm	FMU 40	316Ti/1.4571	52014134
					galv. steel	52014133
				FMU 41	316Ti/1.4571	52014138
					galv. steel	52014137

- The 50 mm or 62 mm orifices serve for the mounting of the FMU 40 or FMU 41 sensor, respectively.
- The 22 mm orifice may be used for an additional sensor.

Mounting Frame

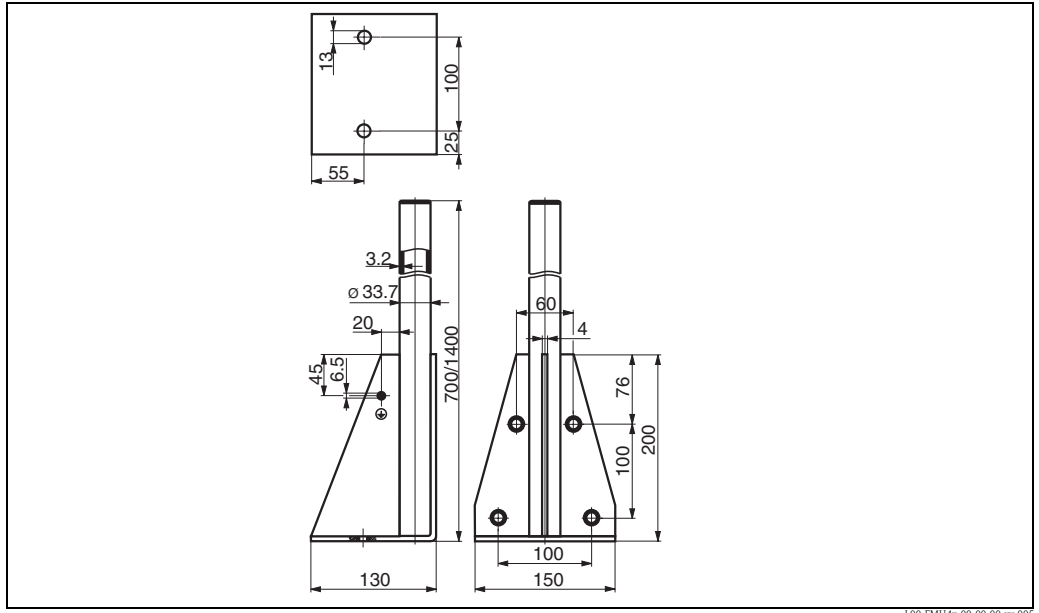

L00-FMU4x-00-00-00-yy-005

Height	Material	Order Code
700 mm	galv. steel	919791-0000
700 mm	1.4301 (AISI 304)	919791-0001
1400 mm	galv. steel	919791-0002
1400 mm	1.4301 (AISI 304)	919791-0003

Wall Bracket

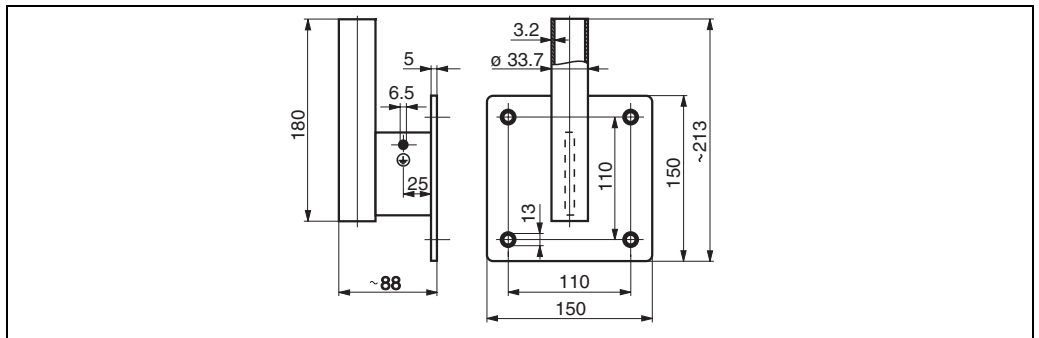

L00-FMU4x-00-00-00-yy-005

Material	Order Code
galv. steel	919792-0000
316Ti/1.4571	919792-0001

Commubox FXA191 HART

For intrinsically safe communication with ToF Tool/FieldCare via the RS232C interface. For details refer to TI237F/00/en.

Commubox FXA195 HART

For intrinsically safe communication with ToF Tool/FieldCare via the USB interface. For details refer to TI404F/00/en.

Service Interface FXA193

The Service-Interface connects the Service plug of Proline and ToF instruments with the 9 pin RS 232C interface of a PC. (USB connectors must be equipped with a usual commercial USB/Serial adapter.)

Product structure

Approvals	
A	For use in non-hazardous areas
B	ATEX II (1) GD
C	CSA/FM Class I Div. 1
D	ATEX, CSA, FM
9	other

Connection cable	
B	Connection cable for ToF devices
E	Connection cable for Proline and ToF devices
H	Connection cable for Proline and ToF devices and Connection cable for Ex two-wire devices
X	without connection cable
9	others

FXA193-			Complete product designation
----------------	--	--	------------------------------

Associated documentation

- Technical Information: TI063D
- Safety Instructions for ATEX II (1) GD: XA077D
- Supplementary information for the cable adapters: SD092D

Commubox FXA291

The Commubox FXA291 connects Endress+Hauser field instruments with CDI interface (= Endress+Hauser Common Data Interface) to the USB interface of a personal computer or a notebook. For details refer to TI405C/07/en.



Note!

For the following Endress+Hauser instruments you need the "ToF Adapter FXA291" as an additional accessory:

- Cerabar S PMC71, PMP7x
- Deltabar S PMD7x, FMD7x
- Deltapilot S FMB70
- Gammapilot M FMG60
- Levelflex M FMP4x
- Micropilot FMR130/FMR131
- Micropilot M FMR2xx
- Micropilot S FMR53x, FMR540
- Prosonic FMU860/861/862
- Prosonic M FMU4x
- Tank Side Monitor NRF590 (with additional adapter cable)
- Prosonic S FMU9x

ToF Adapter FXA291

The ToF Adapter FXA291 connects the Commubox FXA291 via the USB interface of a personal computer or a notebook to the following Endress+Hauser instruments:

- Cerabar S PMC71, PMP7x
- Deltabar S PMD7x, FMD7x
- Deltapilot S FMB70
- Gammapilot M FMG60
- Levelflex M FMP4x
- Micropilot FMR130/FMR131
- Micropilot M FMR2xx
- Micropilot S FMR53x, FMR540
- Prosonic FMU860/861/862
- Prosonic M FMU4x
- Tank Side Monitor NRF590 (with additional adapter cable)
- Prosonic S FMU9x

For details refer to KA271F/00/a2.

Remote display FHX40

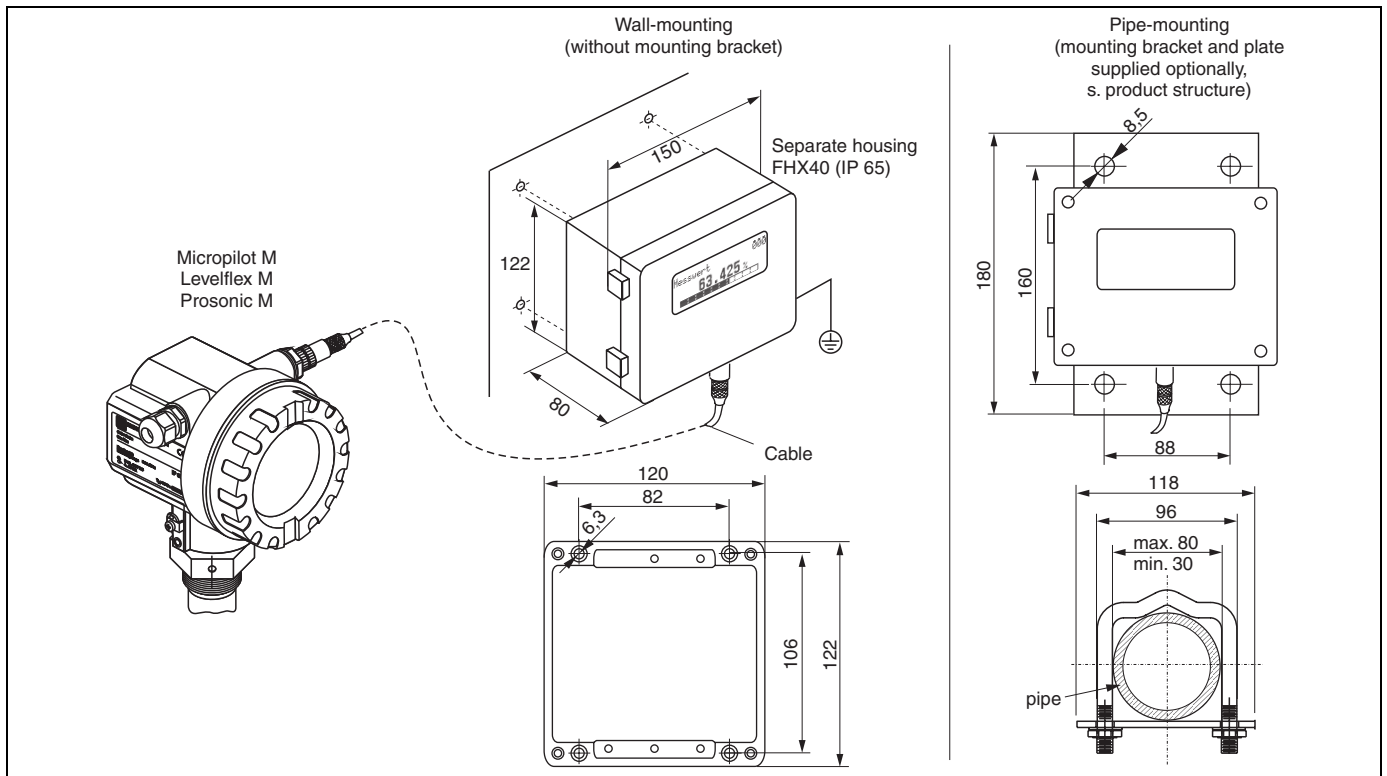

L00-FMxxxxx-00-00-06-en-003

Technical data (cable and housing) and product structure:

Max. cable length	20 m (65 ft)
Temperature range	-30 °C...+70 °C (-22 °F...158 °F)
Degree of protection	IP65/67 (housing); IP68 (cable) acc. to IEC 60529
Materials	Housing: AlSi12; cable glands: nickle plated brass
Dimensions [mm] / [inch]	122x150x80 (HxWxD) / 4.8x5.9x3.2

Approval:	
A	Nn-hazardous area
1	ATEX II 2 G EEx ia IIC T6, ATEX II 3D
S	FM IS Cl.I Div.1 Gr.A-D
U	CSA IS Cl.I Div.1 Gr.A-D
N	CSA General Purpose
K	TIIS ia IIC T6 (in preparation)
Cable:	
1	20m/65ft; for HART
5	20m/65ft; for PROFIBUS PA/FOUNDATION Fieldbus
Additional option:	
A	Basic version
B	Mounting bracket, pipe 1" / 2"
FHX40 -	Complete product designation

For connection of the remote display FHX40 use the cable which fits the communication version of the respective instrument.

Supplementary documentation

System Information

SI 005F

Ultrasonic level measurement

Operating manual

Depending on the communication variant ordered, the following operating manuals are supplied with the device:

Communication	Operating manual
4 ... 20mA, HART	BA 237F
Profibus PA	BA 238F
Foundation Fieldbus	BA 239F

These instructions describe the installation and first commissioning of the Prosonic M. From the operating menu, all functions are included, which are required for standard measurement tasks. Additional functions are **not** contained in the manual.

Description of device functions

BA 240F

This contains a detailed description of **all** the functions of the Prosonic M and is valid for all communication variants.

A pdf file of this document can be found

- in the supplied "ToF Tool - FieldTool Package" at "Help/ToF Tool Help/ Online Manual/ Operating Manual/Ultrasonic/Prosonic M FMU4x Functions"¹⁾.
- in the internet at "www.endress.com". Klick "Download" and enter the product code "FMU4*" into the search form.

Short instructions

KA 183F

can be found under the device housing cover.

The most important menu functions are summarised on this sheet. It is intended primarily as a memory jogger for users who are familiar with the operating concept of Endress+Hauser time-of-flight instruments.

Safety Instructions ATEX

The following safety instructions are supplied with ATEX-certified device versions. If the devices are used in explosive areas, comply with all the specifications in these safety instructions.

Instrument version	Certificate	Communication	Housing	Safety Instructions
<ul style="list-style-type: none"> ■ FMU40 - 1*B*A* ■ FMU41 - 1*B*A* ■ FMU42 - 1*B*A*** 	ATEX II 1/2 G or II 2 G EEx ia II C T6	HART (2-wire)	F12	XA 174F
<ul style="list-style-type: none"> ■ FMU40 - 1*B*D* ■ FMU41 - 1*B*D* ■ FMU42 - 1*B*D*** 	ATEX II 1/2 G or II 2 G EEx ia II C T6	HART (2-wire)	T12 with overvoltage protection	XA 224F
<ul style="list-style-type: none"> ■ FMU40 - 1*D*A* - 1*F*A* ■ FMU41 - 1*D*A* - 1*F*A* ■ FMU42 - 1*D*A*** - 1*F*A*** 	ATEX II 1/2 G or II 2 G EEx ia II C T6	<ul style="list-style-type: none"> ■ Profibus-PA ■ Foundation Fieldbus 	F12	XA 175F
<ul style="list-style-type: none"> ■ FMU40 - 1*D*D* - 1*F*D* ■ FMU41 - 1*D*D* - 1*F*D* ■ FMU42 - 1*D*D*** - 1*F*D*** 	ATEX II 1/2 G or II 2 G EEx ia II C T6	<ul style="list-style-type: none"> ■ Profibus-PA ■ Foundation Fieldbus 	T12 with overvoltage protection	XA 225F

1) If the Operating Instructions have not been installed together with the "ToF Tool - FieldTool Package", they can be added to the installation subsequently.

Instrument version	Certificate	Communication	Housing	Safety Instructions
<ul style="list-style-type: none"> ■ FMU40 - 4*B*C* <li style="padding-left: 20px;">- 4*D*C* <li style="padding-left: 20px;">- 4*F*C* ■ FMU41 - 4*B*C* <li style="padding-left: 20px;">- 4*D*C* <li style="padding-left: 20px;">- 4*F*C* ■ FMU42 - 4*B*C*** <li style="padding-left: 20px;">- 4*D*C*** <li style="padding-left: 20px;">- 4*F*C*** 	ATEX II 1/2 G or II 2 G EEx d [ia] II C T6	<ul style="list-style-type: none"> ■ HART (2-wire) ■ Profibus-PA ■ Foundation Fieldbus 	T12	XA 176F
<ul style="list-style-type: none"> ■ FMU40 - G***** ■ FMU41 - G***** ■ FMU42 - G***** 	ATEX II 3G EEx nA II T6	<ul style="list-style-type: none"> ■ HART (2-wire) ■ HART (4-wire, DC) ■ HART (4-wire, AC) ■ Profibus-PA ■ Foundation Fieldbus 	<ul style="list-style-type: none"> ■ F12 ■ T12 ■ T12 with overvoltage protection 	XA 179F
<ul style="list-style-type: none"> ■ FMU40 - 2*B*A* <li style="padding-left: 20px;">- 2*D*A* <li style="padding-left: 20px;">- 2*F*A* <li style="padding-left: 20px;">- 5*B*A* <li style="padding-left: 20px;">- 5*D*A* <li style="padding-left: 20px;">- 5*F*A* ■ FMU41 - 2*B*A* <li style="padding-left: 20px;">- 2*D*A* <li style="padding-left: 20px;">- 2*F*A* <li style="padding-left: 20px;">- 5*B*A* <li style="padding-left: 20px;">- 5*D*A* <li style="padding-left: 20px;">- 5*F*A* ■ FMU42 - 2*B*A*** <li style="padding-left: 20px;">- 2*D*A*** <li style="padding-left: 20px;">- 2*F*A*** <li style="padding-left: 20px;">- 5*B*A*** <li style="padding-left: 20px;">- 5*D*A*** <li style="padding-left: 20px;">- 5*F*A*** 	<ul style="list-style-type: none"> ■ ATEX II 1/2D ■ ATEX II 1/3D 	<ul style="list-style-type: none"> ■ HART (2-wire) ■ Profibus-PA ■ Foundation Fieldbus 	F12	XA 180F
<ul style="list-style-type: none"> ■ FMU40 - 2*G*A* <li style="padding-left: 20px;">- 2*H*A* <li style="padding-left: 20px;">- 5*G*A* <li style="padding-left: 20px;">- 5*H*A* ■ FMU41 - 2*G*A* <li style="padding-left: 20px;">- 2*H*A* <li style="padding-left: 20px;">- 5*G*A* <li style="padding-left: 20px;">- 5*H*A* ■ FMU42 - 2*G*A*** <li style="padding-left: 20px;">- 2*H*A*** <li style="padding-left: 20px;">- 5*G*A*** <li style="padding-left: 20px;">- 5*H*A*** 	<ul style="list-style-type: none"> ■ ATEX II 1/2D ■ ATEX II 1/3 D 	<ul style="list-style-type: none"> ■ HART (4-wire, DC) ■ HART (4-wire, AC) 	F12	XA 259
<ul style="list-style-type: none"> ■ FMU43 - 2*G*A* <li style="padding-left: 20px;">- 2*H*A* <li style="padding-left: 20px;">- 5*G*A* <li style="padding-left: 20px;">- 5*H*A* 	<ul style="list-style-type: none"> ■ ATEX II 1/2 D or II 2 D ■ ATEX II 1/3 D or II 3 D 	<ul style="list-style-type: none"> ■ HART (4-wire, DC) ■ HART (4-wire, AC) 	F12	XA 177F
<ul style="list-style-type: none"> ■ FMU43 - 2*D*A* <li style="padding-left: 20px;">- 2*F*A* <li style="padding-left: 20px;">- 5*D*A* <li style="padding-left: 20px;">- 5*F*A* 	<ul style="list-style-type: none"> ■ ATEX II 1/2 D or II 2 D ■ ATEX II 1/3 D or II 3 D 	<ul style="list-style-type: none"> ■ Profibus-PA ■ Foundation Fieldbus 	F12	XA 178F

Safety Instructions NEPSI

The following safety instructions are supplied with NEPSI-certified device versions. If the devices are used in explosive areas, comply with all the specifications in these safety instructions.

Instrument version	Certificate	Communication	Housing	Safety Instructions
<ul style="list-style-type: none"> ■ FMU40 - I*B*A* ■ FMU41 - I*B*A* ■ FMU42 - I*B*A*** 	Ex ia II C T1 ... T6 NEPSI GYJ071468	HART (2-wire)	F12	XA 436F
<ul style="list-style-type: none"> ■ FMU40 - I*B*D* ■ FMU41 - I*B*D* ■ FMU42 - I*B*D*** 	Ex ia II C T1 ... T6 NEPSI GYJ071468	HART (2-wire)	T12 with overvoltage protection	XA 442F
<ul style="list-style-type: none"> ■ FMU40 - I*D*A* - I*F*A* ■ FMU41 - I*D*A* - I*F*A* ■ FMU42 - I*D*A*** - I*F*A*** 	Ex ia II C T1 ... T6 NEPSI GYK071468	<ul style="list-style-type: none"> ■ Profibus-PA ■ Foundation Fieldbus 	F12	XA 437F
<ul style="list-style-type: none"> ■ FMU40 - I*D*D* - I*F*D* ■ FMU41 - I*D*D* - I*F*D* ■ FMU42 - I*D*D*** - I*F*D*** 	Ex ia II C T1 ... T6 NEPSI GYJ071468	<ul style="list-style-type: none"> ■ Profibus-PA ■ Foundation Fieldbus 	T12 with overvoltage protection	XA 443F
<ul style="list-style-type: none"> ■ FMU40 - J*B*C* - J*D*C* - J*F*C* ■ FMU41 - J*B*C* - J*D*C* - J*F*C* ■ FMU42 - J*B*C*** - J*D*C*** - J*F*C*** 	Ex d [ia] II C T1 ... T6 NEPSI GYJ071468	<ul style="list-style-type: none"> ■ HART (2-wire) ■ Profibus-PA ■ Foundation Fieldbus 	T12	XA 438F
<ul style="list-style-type: none"> ■ FMU40 - Q*B*A* - Q*D*A* - Q*F*A* ■ FMU41 - Q*B*A* - Q*D*A* - Q*F*A* ■ FMU42 - Q*B*A*** - Q*D*A*** - Q*F*A*** 	DIP A21/A22 T _A , T* NEPSI GYJ071468	<ul style="list-style-type: none"> ■ HART (2-wire) ■ Profibus-PA ■ Foundation Fieldbus 	F12	XA 441F
<ul style="list-style-type: none"> ■ FMU40 - Q*C*A* - Q*H*A* ■ FMU41 - Q*C*A* - Q*H*A* ■ FMU42 - Q*C*A*** - Q*H*A*** 	DIP A21/A22 T _A , T* NEPSI GYJ071468	<ul style="list-style-type: none"> ■ HART (4-wire, DC) ■ HART (4-wire, AC) 	F12	XA 444F
<ul style="list-style-type: none"> ■ FMU43 - Q*C*A* - Q*H*A* 	DIP A21/A22 T _A , T*	<ul style="list-style-type: none"> ■ HART (4-wire, DC) ■ HART (4-wire, AC) 	F12	XA 439F
<ul style="list-style-type: none"> ■ FMU43 - Q*D*A* - Q*F*A* 	DIP A21/A22 T _A , T*	<ul style="list-style-type: none"> ■ Profibus-PA ■ Foundation Fieldbus 	F12	XA 440F
<ul style="list-style-type: none"> ■ FMU40 - E***** ■ FMU41 - E***** ■ FMU42 - E***** 	NEPSI Ex nA IIC T6	<ul style="list-style-type: none"> ■ HART ■ Profibus PA ■ Foundation Fieldbus 	<ul style="list-style-type: none"> ■ F12 ■ T12 	XA 403F

Control drawings Installation drawings The following control or installation drawings are supplied with the FM, CSA and TIIS-certified device versions:

Instrument version	Certificate	Communication	Housing	Control or Installation Drawing
<ul style="list-style-type: none"> ■ FMU40 - S*B*A* ■ FMU41 - S*B*A* ■ FMU42 - S*B*A*** 	FM IS	HART (2-wire)	F12	ZD 096F
<ul style="list-style-type: none"> ■ FMU40 - S*D*A* - S*F*A* ■ FMU41 - S*D*A* - S*F*A* ■ FMU42 - S*D*A*** - S*F*A*** 	FM IS	<ul style="list-style-type: none"> ■ Profibus-PA ■ Foundation Fieldbus 	F12	ZD 097F
<ul style="list-style-type: none"> ■ FMU40 - S*B*D* ■ FMU41 - S*B*D* ■ FMU42 - S*B*D*** 	FM IS	HART (2-wire)	T12 with overvoltage protection	ZD 139F
<ul style="list-style-type: none"> ■ FMU40 - S*D* D* - S*F*D* ■ FMU41 - S*D* D* - S*F*D* ■ FMU42 - S*D* D*** - S*F*D*** 	FM IS	<ul style="list-style-type: none"> ■ Profibus-PA ■ Foundation Fieldbus 	T12 with overvoltage protection	ZD 140F
<ul style="list-style-type: none"> ■ FMU40 - T*B*C* - T*D*C* - T*F*C* ■ FMU41 - T*B*C* - T*D*C* - T*F*C* ■ FMU42 - T*B*C*** - T*D*C*** - T*F*C*** 	FM XP	<ul style="list-style-type: none"> ■ HART (2-wire) ■ Profibus PA ■ Foundation Fieldbus 	T12	ZD 098F
<ul style="list-style-type: none"> ■ FMU40 - U*B*A* ■ FMU41 - U*B*A* ■ FMU42 - U*B*A*** ■ FMU44 - U*B*A*** 	CSA IS	HART (2-wire)	F12	ZD 088F
<ul style="list-style-type: none"> ■ FMU40 - U*D*A* - U*F*A* ■ FMU41 - U*D*A* - U*F*A* ■ FMU42 - U*D*A*** - U*F*A*** ■ FMU44 - U*D*A*** - U*F*A*** 	CSA IS	<ul style="list-style-type: none"> ■ Profibus-PA ■ Foundation Fieldbus 	F12	ZD 099F
<ul style="list-style-type: none"> ■ FMU40 - U*B* D* ■ FMU41 - U*B* D* ■ FMU42 - U*B* D*** ■ FMU44 - U*B* D*** 	CSA IS	HART (2-wire)	T12 with overvoltage protection	ZD 101F
<ul style="list-style-type: none"> ■ FMU40 - U*D*D* - U*F*D* ■ FMU41 - U*D*D* - U*F*D* ■ FMU42 - U*D*D*** - U*F*D*** ■ FMU44 - U*D*D*** - U*F*D*** 	CSA IS	<ul style="list-style-type: none"> ■ Profibus-PA ■ Foundation Fieldbus 	T12 with overvoltage protection	ZD 102F

Instrument version	Certificate	Communication	Housing	Control or Installation Drawing
<ul style="list-style-type: none"> ■ FMU40 - V*B*C* <li style="padding-left: 20px;">- V*D*C* <li style="padding-left: 20px;">- V*F*C* ■ FMU41 - V*B*C* <li style="padding-left: 20px;">- V*D*C* <li style="padding-left: 20px;">- V*F*C* ■ FMU42 - V*B*C*** <li style="padding-left: 20px;">- V*D*C*** <li style="padding-left: 20px;">- V*F*C*** ■ FMU44 - V*B*C*** <li style="padding-left: 20px;">- V*D*C*** <li style="padding-left: 20px;">- V*F*C*** 	CSA XP	<ul style="list-style-type: none"> ■ HART (2-wire) ■ Profibus PA ■ Foundation Fieldbus 	T12	ZD 100F
<ul style="list-style-type: none"> ■ FMU 40 - K***** ■ FMU 41 - K***** 	TIS Ex ia IIC T6	HART	F12	ZD 138F

Instruments International

Endress+Hauser
Instruments International AG
Kaegenstrasse 2
4153 Reinach
Switzerland

Tel. +41 61 715 81 00
Fax +41 61 715 25 00
www.endress.com
info@ii.endress.com

Endress+Hauser 
People for Process Automation

