

Features

Multi-function timer range

83.01 - Multi-function & multi-voltage, 1 Pole

83.02 - Multi-function & multi-voltage, 2 Pole (timed + instantaneous options), external time setting potentiometer option

- 22.5 mm wide
- Eight time scales from 0.05s to 10 days
- High input/output isolation
- Wide supply range (24...240)V AC/DC
- 35 mm rail (EN 60715) mount
- "Blade + cross" - both flat blade and cross head screw drivers can be used to adjust the range and function selectors, the timing trimmer, and to disengage the rail mounting clip
- Multi-voltage versions with "PWM clever" technology

83.01



- Multi-voltage
- Multi-function

83.02



- Multi-voltage
- Multi-function
- Timing can be regulated using ext. Potentiometer
- 2 timed contacts or 1 timed + 1 instantaneous contact

AI: On-delay
DI: Interval
GI: Pulse delayed
SW: Symmetrical flasher (starting pulse on)
BE: Off-delay with control signal
CE: On- and off-delay with control signal
DE: Interval with control signal on
WD: Watchdog (Retriggerable interval with control signal on)

AI: On-delay
DI: Interval
GI: Pulse delayed
SW: Symmetrical flasher (starting pulse on)
BE: Off-delay with control signal
CE: On- and off-delay with control signal
DE: Interval with control signal on
WD: Watchdog (Retriggerable interval with control signal on)

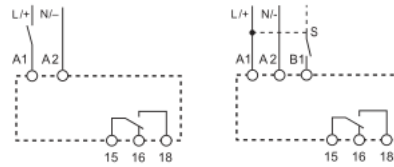

Wiring diagram (without control signal) Wiring diagram (with control signal)

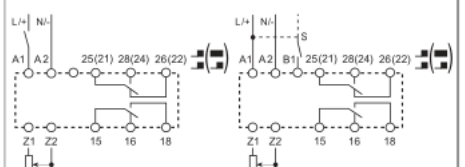

Wiring diagram (without control signal) Wiring diagram (with control signal)

For outline drawing see page 5

Contact specification		83.01	83.02
Contact configuration		1 CO (SPDT)	2 CO (DPDT)
Rated current/Maximum peak current	A	16/30	12/30
Rated voltage/Maximum switching voltage V AC		250/400	250/400
Rated load AC1	VA	4,000	3,000
Rated load AC15 (230 V AC)	VA	750	750
Single phase motor rating (230 V AC)	kW	0.5	0.5
Breaking capacity DC1: 30/110/220 V	A	16/0.3/0.2	12/0.3/0.2
Minimum switching load	mW (V/mA)	300 (5/5)	300 (5/5)
Standard contact material		AgNi	AgNi
Supply specification		83.01	83.02
Nominal voltage (U _N)	V AC (50/60 Hz)	24...240	24...240
	V DC	24...240	24...240
Rated power AC/DC	VA (50 Hz)/W	< 1.5 / < 2	< 2 / < 2
Operating range	V AC	16.8...265	16.8...265
	V DC	16.8...265	16.8...265
Technical data		83.01	83.02
Specified time range		(0.05...1)s, (0.5...10)s, (0.05...1)min, (0.5...10)min, (0.05...1)h, (0.5...10)h, (0.05...1)d, (0.5...10)d	
Repeatability	%	± 1	± 1
Recovery time	ms	200	200
Minimum control impulse	ms	50	50
Setting accuracy-full range	%	± 5	± 5
Electrical life at rated load in AC1	cycles	50 · 10 ³	60 · 10 ³
Ambient temperature range	°C	-20...+60	-20...+60
Protection category		IP 20	IP 20
Approvals (according to type)			

Features

Mono-function timer range

83.11 - ON-delay, multi-voltage

83.21 - Interval, multi-voltage

83.41 - Off-delay with control signal, multi-voltage

- 1 Pole
- 22.5 mm wide
- Eight time scales from 0.05s to 10 days
- High input/output isolation
- Wide supply range (24...240)V AC/DC
- 35 mm rail (EN 60715) mount
- "Blade + cross" - both flat blade and cross head screw drivers can be used to adjust the range and function selectors, the timing trimmer, and to disengage the rail mounting clip
- Multi-voltage versions with "PWM clever" technology

83.11



- Multi-voltage
- Mono-function

AI: On-delay

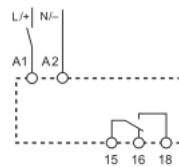

Wiring diagram
(without control signal)

83.21



- Multi-voltage
- Mono-function

DI: Interval

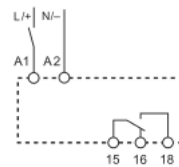

Wiring diagram
(without control signal)

83.41



- Multi-voltage
- Mono-function

BE: Off-delay with control signal

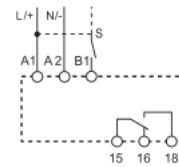

Wiring diagram
(with control signal)

For outline drawing see page 5

Contact specification

Contact configuration		1 CO (SPDT)	1 CO (SPDT)	1 CO (SPDT)
Rated current/Maximum peak current	A	16/30	16/30	16/30
Rated voltage/Maximum switching voltage	V AC	250/400	250/400	250/400
Rated load AC1	VA	4,000	4,000	4,000
Rated load AC1.5 (230 V AC)	VA	750	750	750
Single phase motor rating (230 V AC)	kW	0.5	0.5	0.5
Breaking capacity DC1: 30/110/220 V	A	16/0.3/0.12	16/0.3/0.12	16/0.3/0.12
Minimum switching load	mW (V/mA)	300 (5/5)	300 (5/5)	300 (5/5)
Standard contact material		AgNi	AgNi	AgNi

Supply specification

Nominal voltage (U _N)	V AC (50/60 Hz)	24...240	24...240	24...240
	V DC	24...240	24...240	24...240
Rated power AC/DC	VA (50 Hz)/W	< 1.5 / < 2	< 1.5 / < 2	< 1.5 / < 2
Operating range	V AC	16.8...265	16.8...265	16.8...265
	V DC	16.8...265	16.8...265	16.8...265

Technical data

Specified time range		(0.05...1)s, (0.5...10)s, (0.05...1)min, (0.5...10)min, (0.05...1)h, (0.5...10)h, (0.05...1)d, (0.5...10)d		
Repeatability	%	± 1	± 1	± 1
Recovery time	ms	200	200	200
Minimum control impulse	ms	—	—	50
Setting accuracy-full range	%	± 5	± 5	± 5
Electrical life at rated load in AC1	cycles	50 · 10 ³	50 · 10 ³	50 · 10 ³
Ambient temperature range	°C	-20...+60	-20...+60	-20...+60
Protection category		IP 20	IP 20	IP 20

Approvals (according to type)



Features

- Mono-function and multi-function timer range
- 83.62 - Power off-delay, multi-voltage, 2 Pole
- 83.82 - Star-Delta, multi-voltage, star and delta output contacts
- 83.91 - Asymmetrical flasher, multi-voltage, 1 Pole
- 22.5 mm wide
- Time scales:
Type 83.62 - 0.05s to 3 minutes
Type 83.82 / 83.91 - 0.05 s to 10 days
- Wide supply range (24...240)V AC / DC
- 35 mm rail (EN 60715) mount

- * (0.05...2)s, (...16)s, (8...70)s, (50...180)s
- ** (0.05...1)s, (0.5...10)s, (0.05...1)min, (0.5...10)min, (0.05...1)h, (0.5...10)h, (0.05...1)d, (0.5...10)d
- *** 0.05 s, 0.2 s, 0.3 s, 0.45 s, 0.6 s, 0.75 s, 0.85 s, 1 s

For outline drawing see page 5

Contact specification

Contact configuration	2 CO (DPDT)	2 NO (DPST-NO)	1 CO (SPDT)
Rated current/Maximum peak current A	8/15	6/30	16/30
Rated voltage/Maximum switching voltage V AC	250/400	250/400	250/400
Rated load AC1 VA	2,000	4,000	4,000
Rated load AC15 (230 V AC) VA	400	750	750
Single phase motor rating (230 V AC) kW	0.3	0.5	0.5
Breaking capacity DC1 : 30/110/220 V A	8/0.3/0.12	16/0.3/0.12	16/0.3/0.12
Minimum switching load mW (V/mA)	300 (5/5)	300 (5/5)	300 (5/5)
Standard contact material	AgNi	AgNi	AgNi

Supply specification

Nominal voltage (U _N)	V AC (50/60 Hz)	24...240	24...240	24...240
	V DC	24...220	24...240	24...240
Rated power AC/DC	VA (50 Hz)/W	< 1.5 / < 2	< 1.5 / < 2	< 1.5 / < 2
Operating range	V AC	16.8...265	16.8...265	16.8...265
	V DC	16.8...242	16.8...265	16.8...265

Technical data

Specified time range		*	**
Repeatability %		±	±
Recovery time ms		—	200
Minimum control impulse ms		500 ms (A1 - A2)	50
Setting accuracy-full range %		± 5	± 5
Electrical life at rated load in AC cycles		100·10 ³	50·10 ³
Ambient temperature range °C		-20...+60	-20...+60
Protection category		IP 20	IP 20

Approvals (according to type)



83.62



- Multi-voltage
- Mono-function
- 2 pole

BI: Power off-delay (True off-delay)

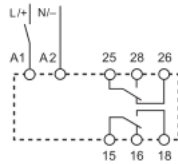

Wiring diagram (without control signal)

83.82



- Multi-voltage
- Mono-function
- 2 pole
- Transfer time can be regulated (0.05...1)s ***

SD: Star-delta

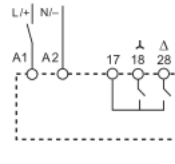

Wiring diagram (without control signal)

83.91



- Multi-voltage
- Multi-function

- LI: Asymmetrical flasher (starting pulse on)
- LE: Asymmetrical flasher (starting pulse on) with control signal
- PI: Asymmetrical flasher (starting pulse off)
- PE: Asymmetrical flasher (starting pulse off) with control signal

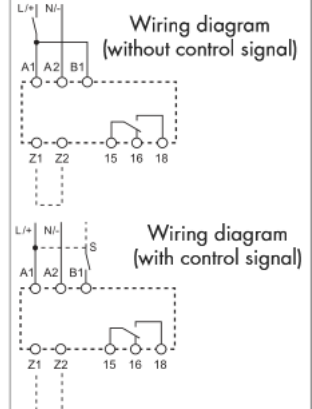

Ordering information

Example: 83 series, modular timers, 1 CO (SPDT) - 16 A, supply rated at (24...240)V AC/DC.

8 3 . 0 1 . 0 . 2 4 0 . 0 0 0 0

Series

Type

0 = Multi-function (AI, DI, GI, SW, BE, CE, DE, WD)

1 = On-delay (AI)

2 = Interval (DI)

4 = Off-delay with control signal (BE)

6 = Power off-delay (True off-delay) (BI)

8 = Star-delta (SD)

9 = Asymmetrical flasher (LI, LE, PI, PE)

Versions

0000 = Standard

Supply voltage

240 = (24 ... 240)V AC/DC

Supply version

0 = AC (50/60 Hz)/DC

No. of poles

1 = 1 CO (SPDT)

2 = 2 CO (DPDT) for 83.02 and 83.62

2 = 2 NO (DPST-NO) for 83.82

Technical data

Insulation					
Dielectric strength	between input and output circuit	V AC	4,000		
	between open contacts	V AC	1,000		
Insulation ($t = 2/50 \mu\text{s}$) between input and output		kV	6		
EMC specifications					
Type of test		Reference standard	83.01/02/11/21/41/82/91	83.62	
Electrostatic discharge	contact discharge	EN 61000-4-2	4 kV	4 kV	
	air discharge	EN 61000-4-2	8 kV	8 kV	
Radio-frequency electromagnetic field	(80 ÷ 1,000 MHz)	EN 61000-4-3	10 V/m	10 V/m	
	(1,000 ÷ 2,700 MHz)	EN 61000-4-3	3 V/m	3 V/m	
Fast transients (burst) (5-50 ns, 5 and 100 kHz)	on Supply terminals	EN 61000-4-4	7 kV	6 kV	
	on control signal terminal (B1)	EN 61000-4-4	7 kV	6 kV	
Surges (1.2/50 μs) on Supply terminals	common mode	EN 61000-4-5	6 kV	6 kV	
	differential mode	EN 61000-4-5	6 kV	4 kV	
	on control signal terminal (B1)	common mode	EN 61000-4-5	6 kV	6 kV
		differential mode	EN 61000-4-5	4 kV	4 kV
Radio-frequency common mode on Supply terminals	(0.15 ÷ 80 MHz)	EN 61000-4-6	10 V	10 V	
	(80 ÷ 230 MHz)	EN 61000-4-6	10 V	10 V	
Radiated and conducted emission		EN 55022	class A	class A	
Other data					
Current absorption on control signal (B1)			< 1 mA		
- max cable length (capacity of $\leq 10 \text{ nF} / 100 \text{ m}$)			150 m		
- when applying a control signal to B1, which is different from the supply voltage at A1/A2			B1 is isolated from A1 and A2 by an opto-coupler, and can therefore be operated at a voltage other than the supply voltage. If using a control signal of between (24... 48)V DC and a supply voltage of (24...240)V AC, ensure that the signal – is connected to A2 and the + is applied to B1, and that L is applied to B1 and N to A2.		
External potentiometer for 83.02			Use a $10 \text{ k}\Omega / \geq 0,25 \text{ W}$ linear potentiometer. Maximum cable length 10 m. When using an external potentiometer, the timer automatically use its setting in place of the internal setting. Consider the voltage potential at the potentiometer to be the same as the timer supply voltage.		
Power lost to the environment	without contact current	W	1.4		
	with rated current	W	3.2		
Screw torque		Nm	0.8		
Max. wire size			solid cable	stranded cable	
		mm ²	1x6 / 2x4	1x4 / 2x2.5	
		AWG	1x10 / 2x12	1x12 / 2x14	

Outline drawings

83.01
Screw terminal

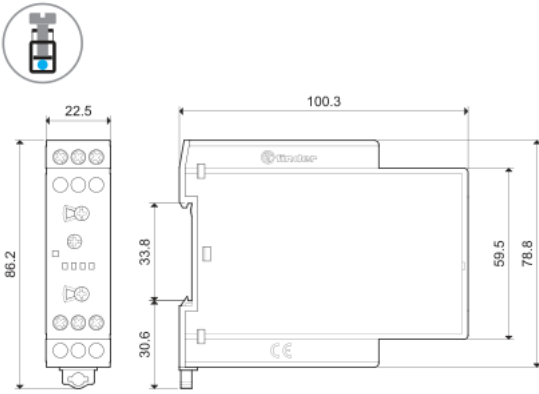

83.02
Screw terminal

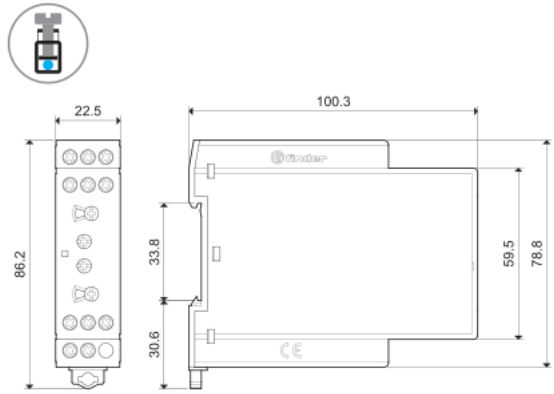

83.11
Screw terminal

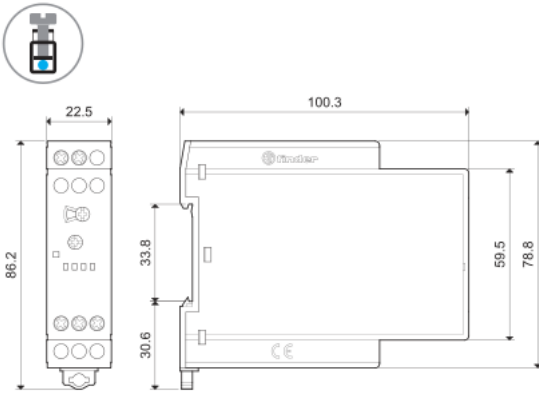

83.21
Screw terminal

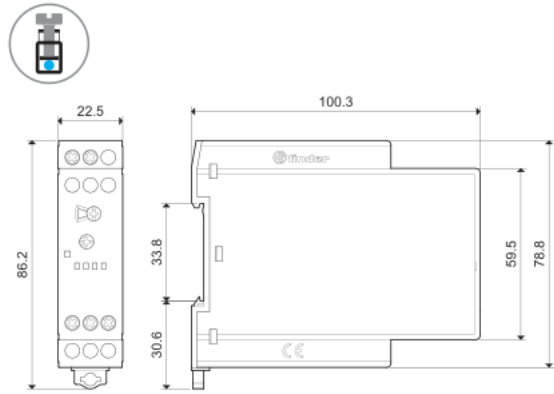

83.41
Screw terminal

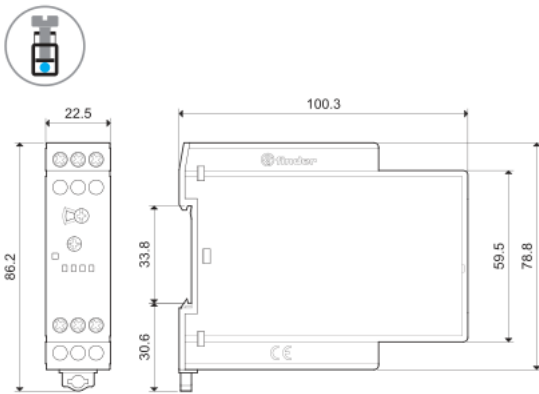

83.62
Screw terminal

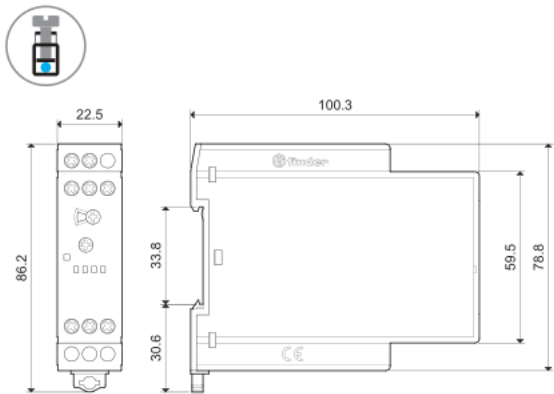

83.82
Screw terminal

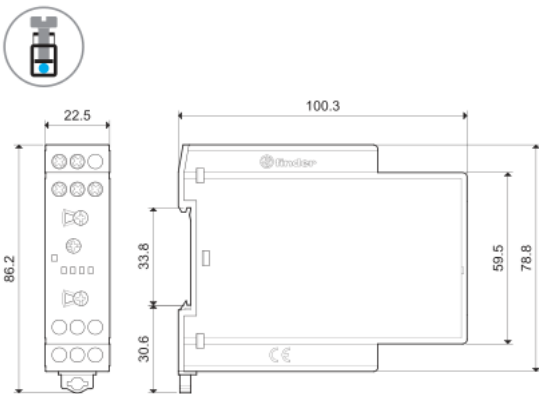

83.91
Screw terminal

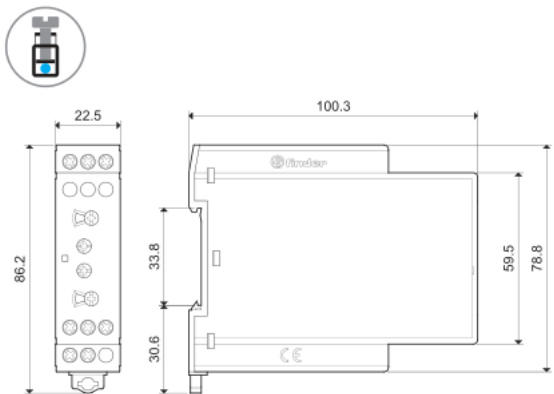

Accessories

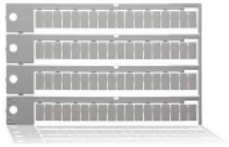

060.72

Sheet of marker tags, for types 83.01 / 11 / 21 / 41 / 62 / 82, plastic, 72 tags, 6x12 mm | 060.72



087.02.2

Potentiometer usable as external potentiometer for type 83.02
10 kΩ / 0.25 W linear

087.02.2

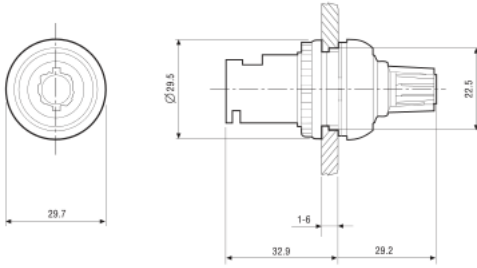

Functions

LED*	Supply voltage	NO output contact	Contacts	
			Open	Closed
	OFF	Open	15 - 18 25 - 28	15 - 16 25 - 26
	ON	Open	15 - 18 25 - 28	15 - 16 25 - 26
	ON	Open (Timing in Progress)	15 - 18 25 - 28	15 - 16 25 - 26
	ON	Closed	15 - 16 25 - 26	15 - 18 25 - 28

* The LED on type 83.62 is illuminated when supply voltage is supplied to timer.

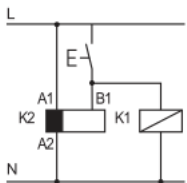

• Possible to control an external load, such as another relay coil or timer, connected to the control signal terminal B1.

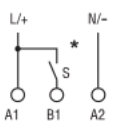

* With DC supply, positive polarity has to be connected to B1 terminal (according to EN 60204-1).

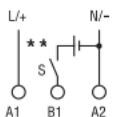

** A voltage other than the supply voltage can be applied to the control signal (B1), example:
A1 - A2 = 230 V AC
B1 - A2 = 12 V DC

Functions

Wiring diagram

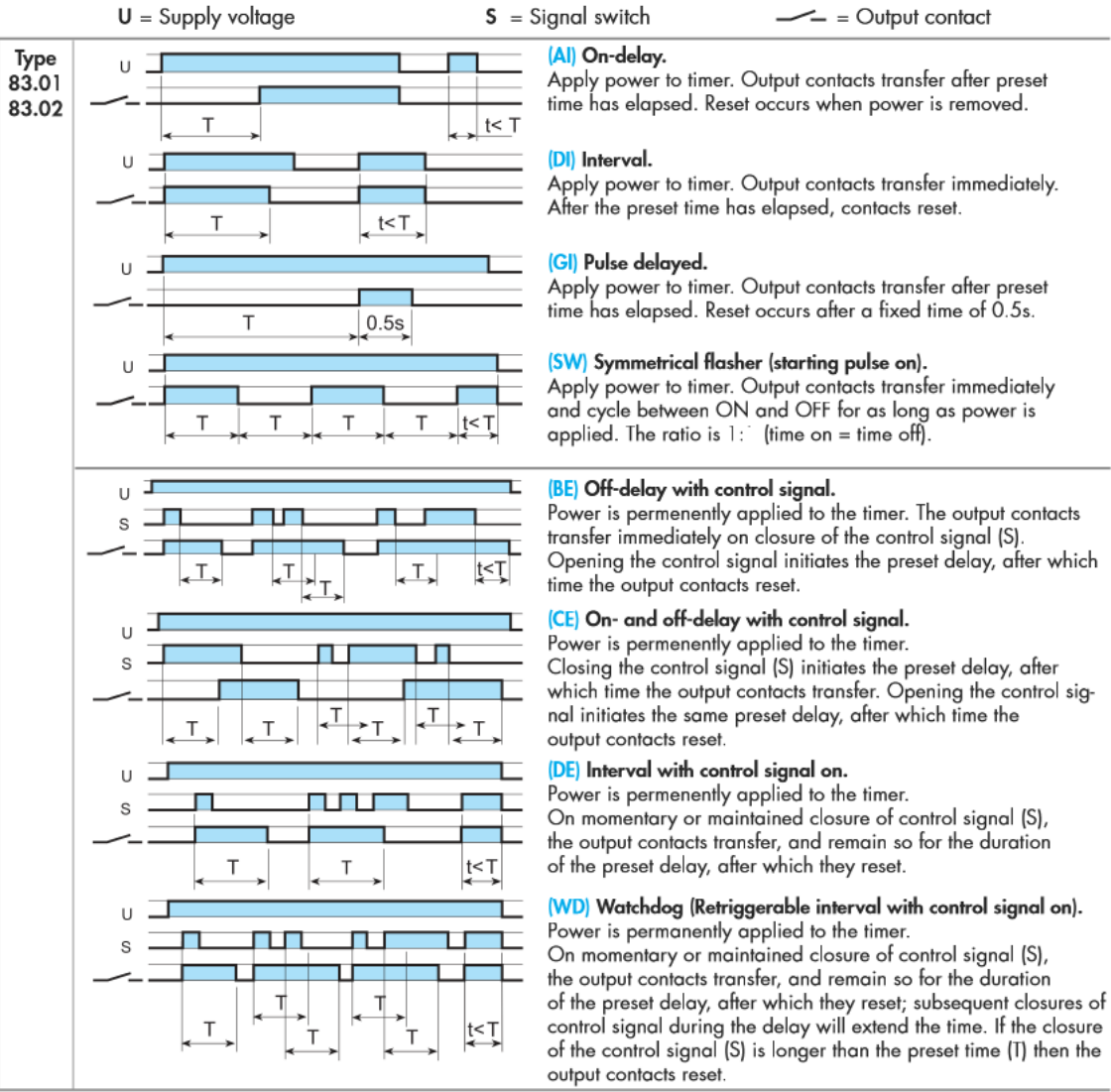
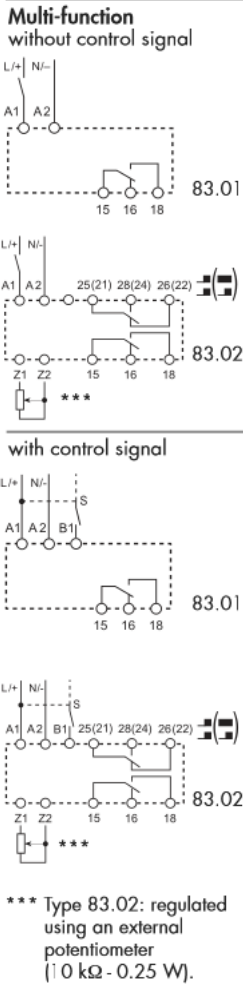

NOTE: The timing function must be set when the timer is de-energised. Or for the 83.02, when the contact mode selector is in the OFF position.

83.02 type

Contact mode selector	Functions without control signal (example: AI)	Functions with control signal (example: BE)
<p>2 timed contacts</p>	<p>Both output contacts (15-18 and 25-28) follow the timing function</p>	<p>Both output contacts (15-18 and 25-28) follow the timing function</p>
<p>OFF</p>	<p>Both output contacts [15-18 and 25(21)-28(24)] stay permanently open</p>	<p>Both output contacts [15-18 and 25(21)-28(24)] stay permanently open</p>
<p>1 timed + 1 instantaneous contact</p>	<p>The output contact 15-18 follows the timing function The output contact 21-24 follows the power supply (U)</p>	<p>The output contact 15-18 follows the timing function The output contact 21-24 follows the control signal (S)</p>

Functions

Wiring diagram

U = Supply voltage

S = Signal switch

 = Output contact

Mono-function
without control signal

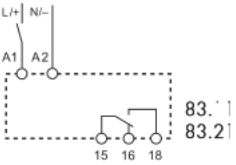

Type
83.11

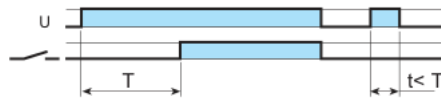

(AI) On-delay.
Apply power to timer. Output contacts transfer after preset time has elapsed. Reset occurs when power is removed.

83.21

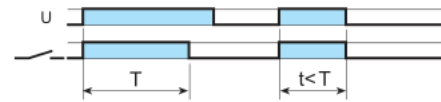

(DI) Interval.
Apply power to timer. Output contacts transfer immediately. After the preset time has elapsed, contacts reset.

83.62

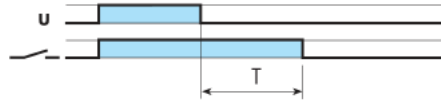

(BI) Power off-delay (True off-delay).
Apply power to timer (minimum 500 ms). Output contacts transfer immediately. Removal of power initiates the preset delay, after which time the output contacts reset.

83.82

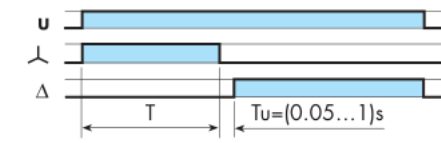

(SD) Star-delta.
Apply power to timer. The star contact (λ) closes immediately. After preset delay has elapsed the star contact (λ) resets. After a further time (settable from 0.05s to 1s) the delta contact (Δ) closes and remains in that position, until reset on power off.

with control signal (S)

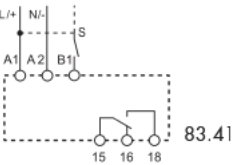

83.41

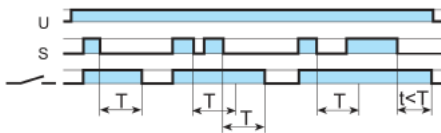

(BE) Off-delay with control signal.
Power is permanently applied to the timer. The output contacts transfer immediately on closure of the control signal (S). Opening the control signal initiates the preset delay, after which time the output contacts reset.

Asymmetrical recycler
without control signal

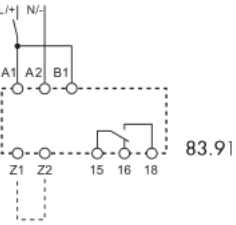

83.91

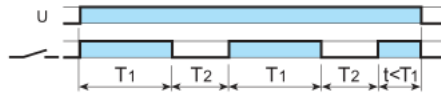

(LI) Asymmetrical flasher (starting pulse on) - (Z1-Z2 open).
Apply power to timer. Output contacts transfer immediately and cycle between ON and OFF for as long as power is applied. The ON and OFF times are independently adjustable.

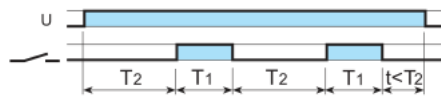

(PI) Asymmetrical flasher (starting pulse off) - (Z1-Z2 linked).
Apply power to timer. Output contacts transfer after time T2 has elapsed and cycle between OFF and ON for as long as power is applied. The ON and OFF times are independently adjustable.

with control signal

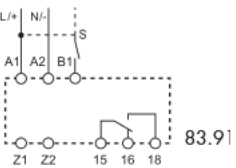

83.91

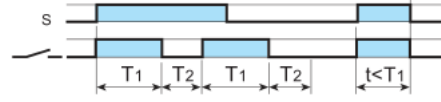

(LE) Asymmetrical flasher (starting pulse on) with control signal - (Z1-Z2 open).
Power is permanently applied to the timer. Closing control signal (S) causes the output contacts to transfer immediately and cycle between ON and OFF, until opened.

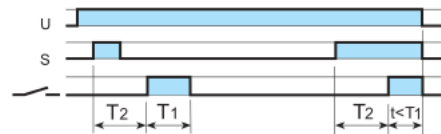

(PE) Asymmetrical flasher (starting pulse off) with control signal - (Z1-Z2 linked).
Power is permanently applied to the timer. Closing the control signal (S) initiates delay T2 after which the output contacts transfer and continue to cycle between OFF and ON, until the control signal is opened.

Z1-Z2 open: **(LI)** function
Z1-Z2 linked: **(PI)** function

Z1-Z2 open: **(LE)** function
Z1-Z2 linked: **(PE)** function