



Product info sheet no. C 2.4
Humidity/temperature sensor
Meteorological design

Description

MELA-humidity/temperature sensors in the PC-ME and RC-ME series are compact sensors in a rod-type design with a fixed connecting cable (5 m) or with a robust aluminium connecting head and terminal screws and a high degree of accuracy, which have been specially developed for meteorological applications. The **ZE 20-type** membrane filter, which is fitted as standard, provides the element with reliable protection outdoors. We recommend that you use the version with the **ZE 21-type** sintered high-grade steel filter at particularly high wind speeds or if the sensor is exposed to salt mist and sand (close to the sea, desert, mountains, areas with high wind speeds, and the likes). Use of capacitive humidity sensor elements is a guarantee of:

- high long-term stability
- almost linear characteristic curve
- good dynamic performance
- resistance to dew formation
- small hysteresis.

Technical data

Humidity

Measuring range 0...100% rh
Accuracy (MR 5...95%rh at 10...40°C) ±2% rh
at <10°C, >40°C <0.1%/K additional
Response time (at calm air) < 20 sec

Temperature

Measuring element (DIN EN 60751) Pt 100 1/3 DIN
Measuring range -30...+70°C
Accuracy
Output: 0...1V (-27...70°C) ±0.2 K
0...10V (-29...70°C) ±0.2 K
4...20mA (RC) ±0.3 K
at <10°C, >40°C ±0.007K/K additional

Other data

Ambient temperature -40...+80°C
Degree of protection sensor/electronic IP 30/IP 65
Operating voltage
U-output 0...10V 15...30V DC
U-output 0...1V 6...30V DC
I-output 12...30V DC

min. load resistance 0...10V/0...1V ≥10kΩ/≥2kΩ
Load (current-output) acc. diagramm
Power consumption
0...10V, 2 x 0...1V <5mA
0...1V <1mA
Minimum air speed
(across the sensor):
Output: 0...10V, 2x0...1V ≥0.5m/s
4...20mA, 2 x 0...10V ≥1.5m/s
2x 4...20mA ≥1.5 m/s
Self-heating Pt 100 (1m/s, 2mA, 20°C) 0.1 K
Electromagnetic compatibility
Emitted interference EN 55011 cl. B
Noise immunity EN 50082-2
„subject to technical modifications“

Type versions

Measuring unit	Analogue output	with	with
		membrane filter ZE 20	sintered filter ZE 21
F rel. humidity	0...10 V	FPC 2/5 - ME	FPC 2/6 - ME
	0...1V	FPC 1/5 - ME*	FPC 1/6 - ME*
C r.h. + temp.	0...10 V, Pt 100	CPC 2/5 - ME	CPC 2/6 - ME
	0...1 V, Pt 100	CPC 1/5 - ME*	CPC 1/6 - ME*
K r.h. + temp.	2 x 0...10 V	KPC 2/5 - ME	KPC 2/6 - ME
	2 x 0...1 V	KPC 1/5 - ME	KPC 1/6 - ME
T Temperature	Pt 100	TPC 5/5 - ME	TPC 5/6 - ME
	0...10 V	TPC 2/5 - ME	TPC 2/6 - ME
	0...1 V	TPC 1/5 - ME	TPC 1/6 - ME
Weight		ca. 310 g	ca. 320 g

Measuring unit	Analogue output	with	with
		connecting head ZE 20	connecting head ZE 21
F rel. humidity	4...20 mA	FRC 3/5 - ME	FRC 3/6 - ME
	0...10 V	FRC 2/5 - ME	FRC 2/6 - ME
	0...1V	FRC 1/5 - ME	FRC 1/6 - ME
C r.h. + temp.	4...20 mA, Pt 100	CRC 3/5 - ME	CRC 3/6 - ME
	0...10 V, Pt 100	CRC 2/5 - ME	CRC 2/6 - ME
	0...1 V, Pt 100	CRC 1/5 - ME	CRC 1/6 - ME
K r.h. + temp.	2 x 4...20 mA	KRC 3/5 - ME	KRC 3/6 - ME
	2 x 0...10 V	KRC 2/5 - ME	KRC 2/6 - ME
	2 x 0...1 V	KRC 1/5 - ME	KRC 1/6 - ME
T Temperature	Pt 100	TRC 5/5 - ME	TRC 5/6 - ME
	4...20 mA	TRC 3/5 - ME	TRC 3/6 - ME
	0...10 V	TRC 2/5 - ME	TRC 2/6 - ME
	0...1 V	TRC 1/5 - ME	TRC 1/6 - ME
Weight		ca. 60 g	ca. 90 g

Special versions available on request

This information is based on current knowledge and is intended to provide details of our products and their possible applications. It does not, therefore, act as a guarantee of specific properties of the products described or of their suitability for a particular application. It is our experience that the equipment may be used across a broad spectrum of applications under the most varied conditions and loads. We cannot appraise every individual case. Purchasers and/or users are responsible for checking the equipment for suitability for any particular application. Any existing industrial rights of protection must be observed. The perfect quality of our products is guaranteed under our General Conditions of Sale. Issue : March 2004 valid until 31.12.2005 C24_E. Subject to modifications, current version available at www.galltec.de. This issue supersedes all previous technical leaflets.

User instructions

Install the humidity/-temperature sensors in a place where characteristic climatic conditions can be measured. If it is used outdoors, it should ideally be used in a ZA 161/1-type weather guard. Avoid direct sunlight.

The specified minimum air speeds and the operating voltage-adapted current at current-output (diagram) should be complied with. Deviations may lead to additional corrupted measurement readings because the sensor self-heats.

The sensor can be installed in any position. However, do not position it in a position where water ingress can occur. Dew formation and splashes do not damage the sensor, although corrupted measurement readings are recorded until all the moisture on and directly around the sensor element has dried up.

In order to maintain interference immunity in accordance with EN 80082-2 when it is in use, we recommend that you use a screened cable for connecting the RC series sensors, and have this fitted into the sensor's EMC heavy-gauge conduit thread by a qualified electrician.

The protective filter should only be screwed off carefully to check functioning with a humidity standard.

Take care not to touch the highly sensitive sensor element. If necessary, soiled ZE 21-type sintered filters can be screwed off and rinsed. When you screw them back on, bear in mind that sensors will not measure accurately again until they are completely dry.

For mounting support we recommend a **console type 20.009** and an **attachment plate type ZA 20** (Product info sheet No. F5.1). In order to check functioning in the place of installation, we recommend that you use the **ZE 31/1-type humidity standard** (product info sheet no. F 5.2)

Please consult the **application instructions** for the sensing elements (product info sheet no. A 1) or check with the manufacturer for further information which you need to bear in mind when using humidity sensors with capacitive sensing elements.

Load at current output

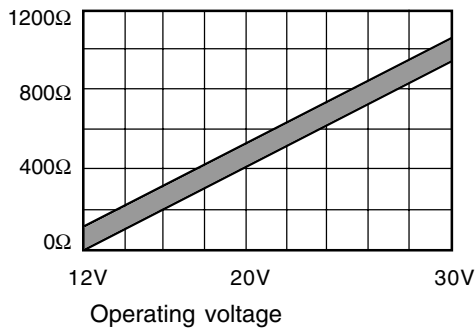

Tolerance validity range for humidity

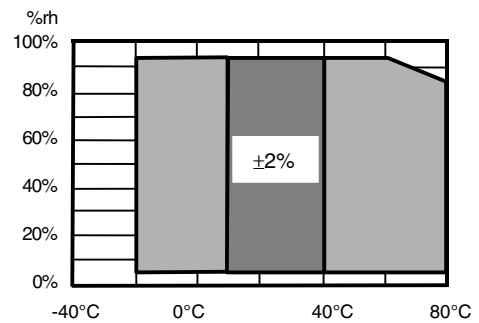

Dimensions

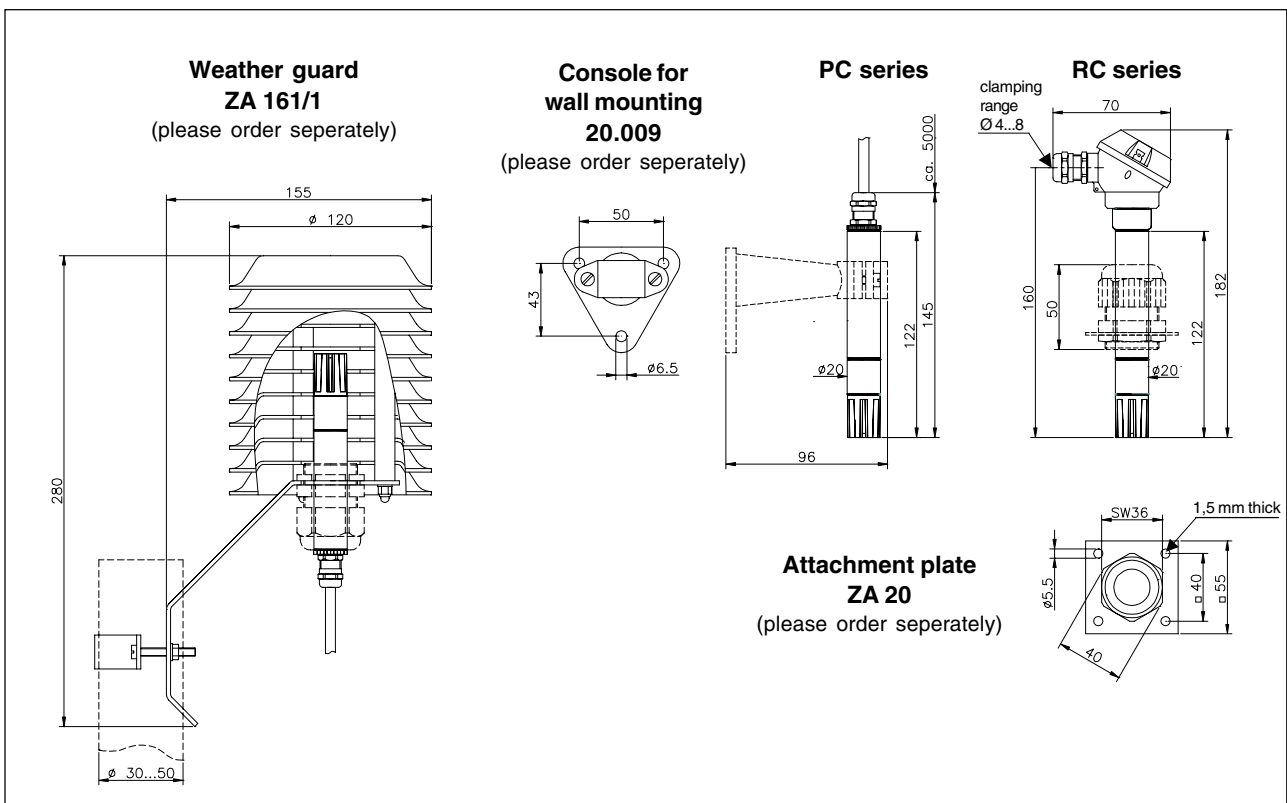

Connection diagram

Humidity-temperature sensors

Meteorological design series PC-ME

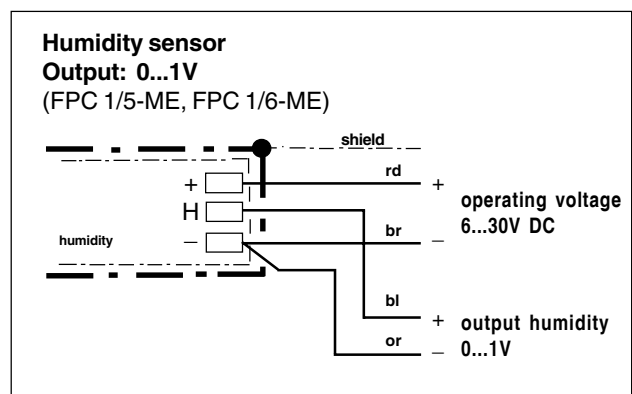
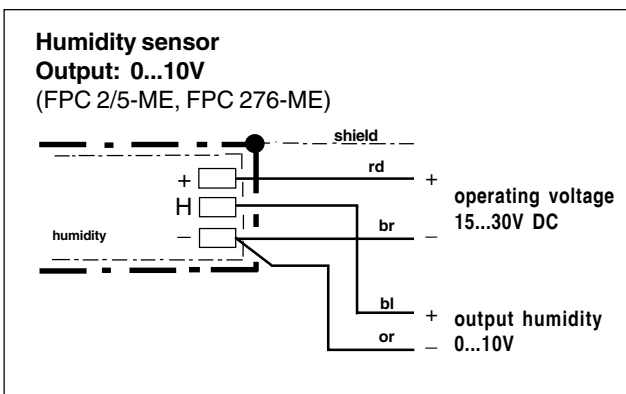
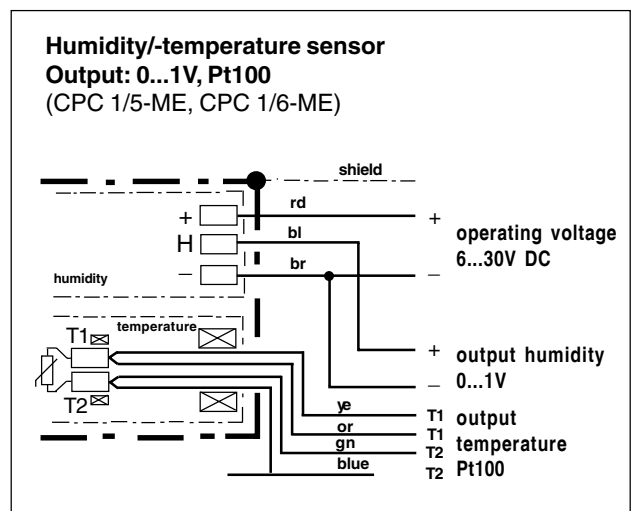
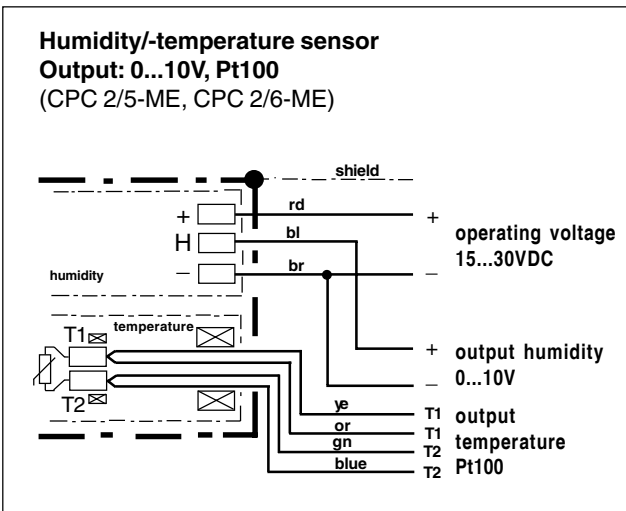
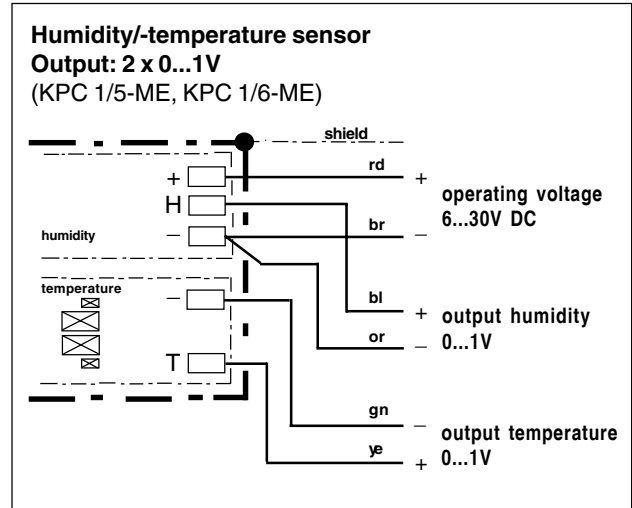
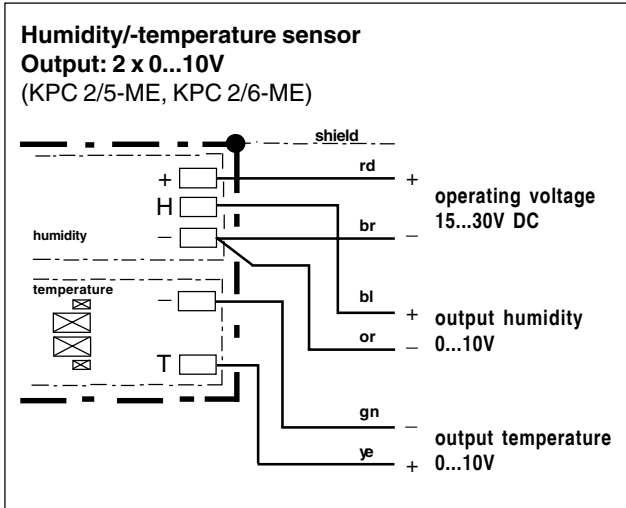

Connection diagram

Humidity/temperature sensors Meteorological design series PC-ME

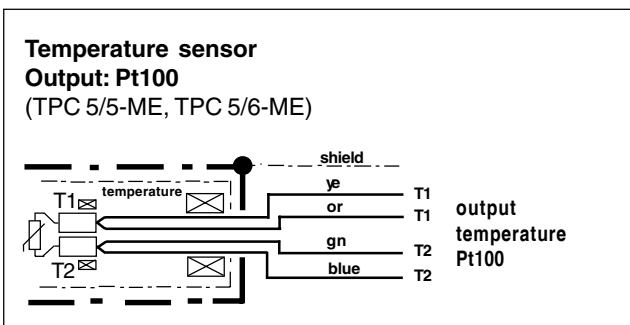
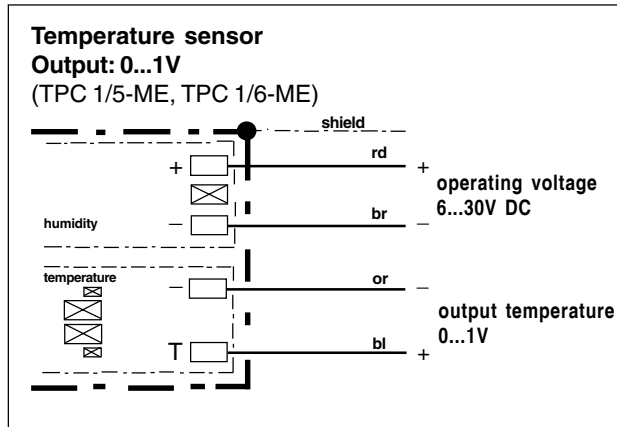
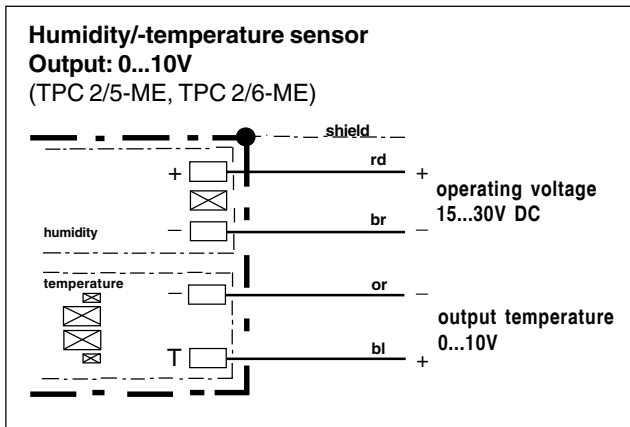

Connection diagram

Humidity/temperature sensors

Meteorological design series RC-ME

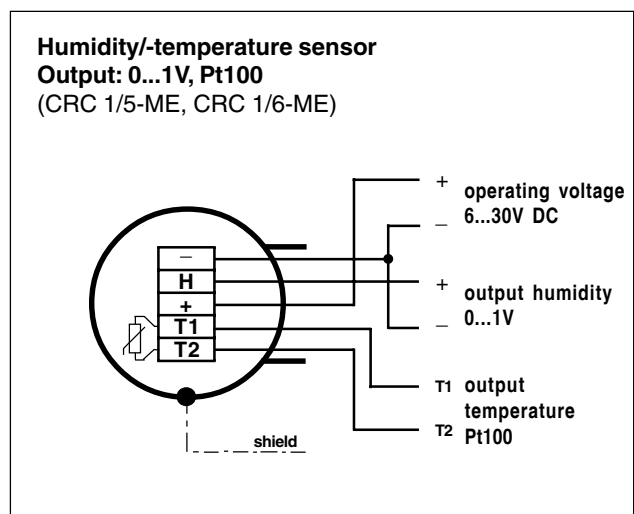
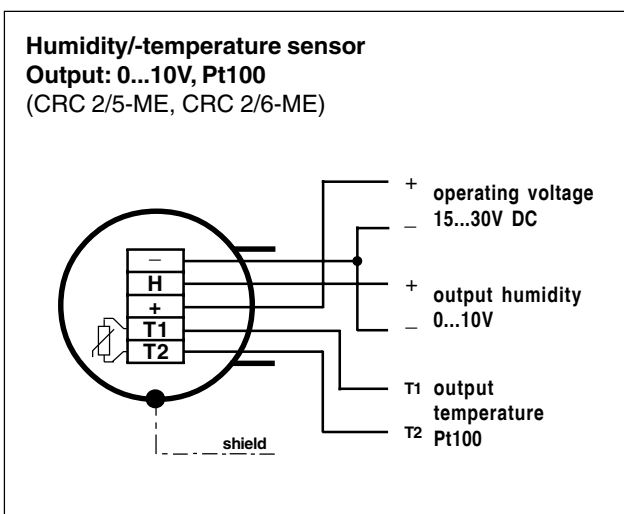
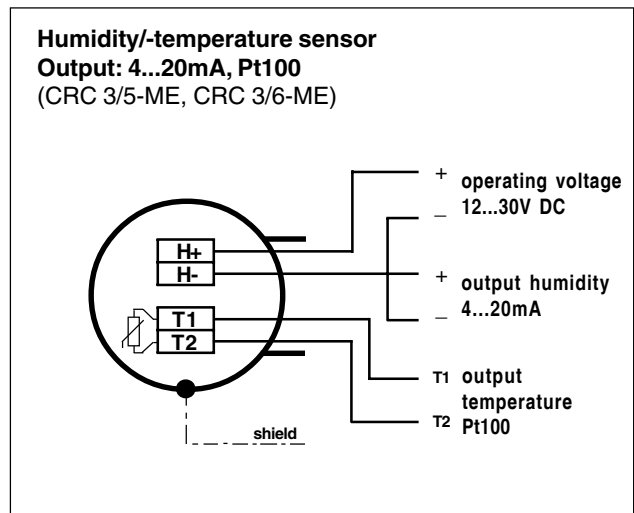
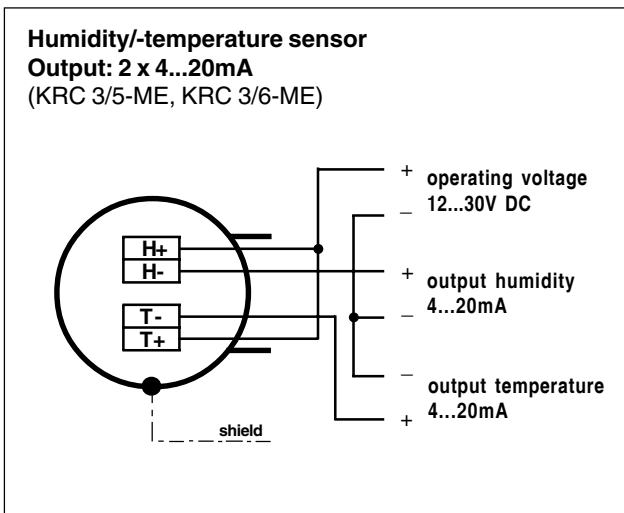
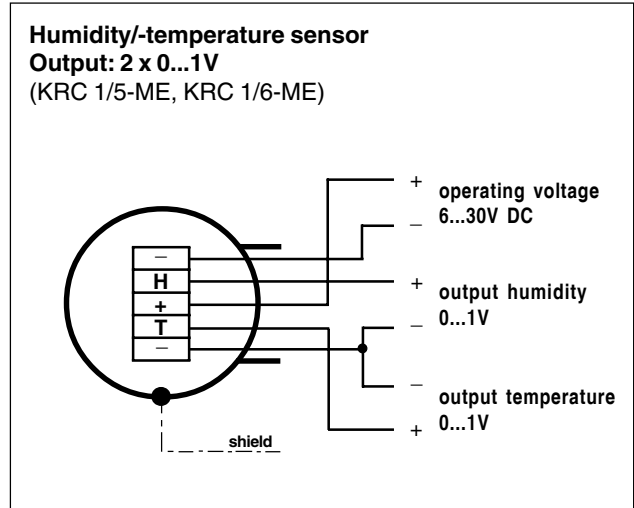
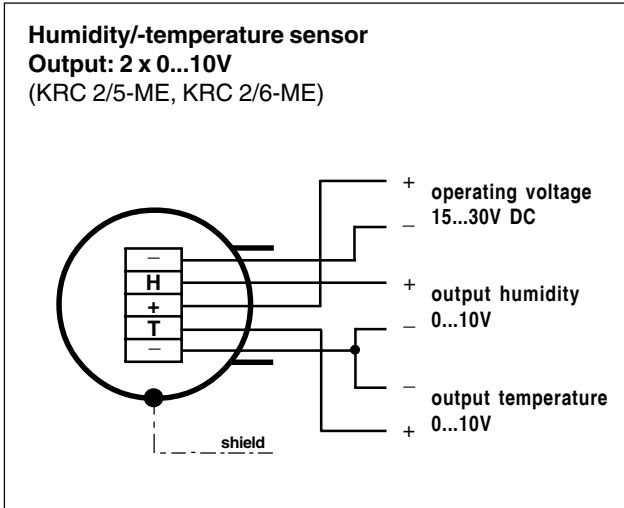

Connection diagram

Humidity/temperature sensors

Meteorological design series RC-ME

