



Q.bloxx A108

Multi Channel Module for Dynamic Voltages



The Q.series has been designed for demanding measurements found in today's most industrial measuring and testing environments. The range of applications starts from single stand-alone solutions up to networked multi-channel applications in the field of component testing, engine testing, process performance testing and structural monitoring.

The range and flexibility of the modules allows an optimized solution for each single task:
Dynamic signal acquisition up to 100 kHz, inputs and outputs for all types of signals, galvanic isolation of inputs and outputs, multi-channel solutions, high density packaging and intelligent signal conditioning.

Data exchange between Test Controller and automation level is communicated via Ethernet TCP/IP or fieldbus systems like EtherCAT or Profibus-DP and additional Ethernet-based industrial standards.

Most important features:

- **8 galvanic isolated input channels**
differential voltage, current via shunt connector;
Isolation voltage 500 VDC
- **Fast and high accuracy digitalization**
24 bit ADC, 10 kHz sample rate per channel with 8 active channels,
- **2 digital in and 2 outputs**
input: state, tare, memory reset
output: state, alarm, threshold
- **Signal conditioning**
linearization, digital filter, average, scaling,
min/max storage, RMS, arithmetic, alarm
- **RS485 fieldbus-interface**
up to 48 Mbps: LocalBus
up to 115,2 kbps: Modbus-RTU, ASCII
- **Connectable to any Test Controller**
e.g. Q.gate or Q.pac
- **Galvanic isolation**
channel to channel to power supply and to interface
Isolation voltage 500 VDC
- **Electromagnetic Compatibility**
according EN 61000-4 and EN 55011
- **Accuracy class 0,01**
- **Power supply 10...30 VDC**
- **DIN rail mounting (EN 50022 rail)**

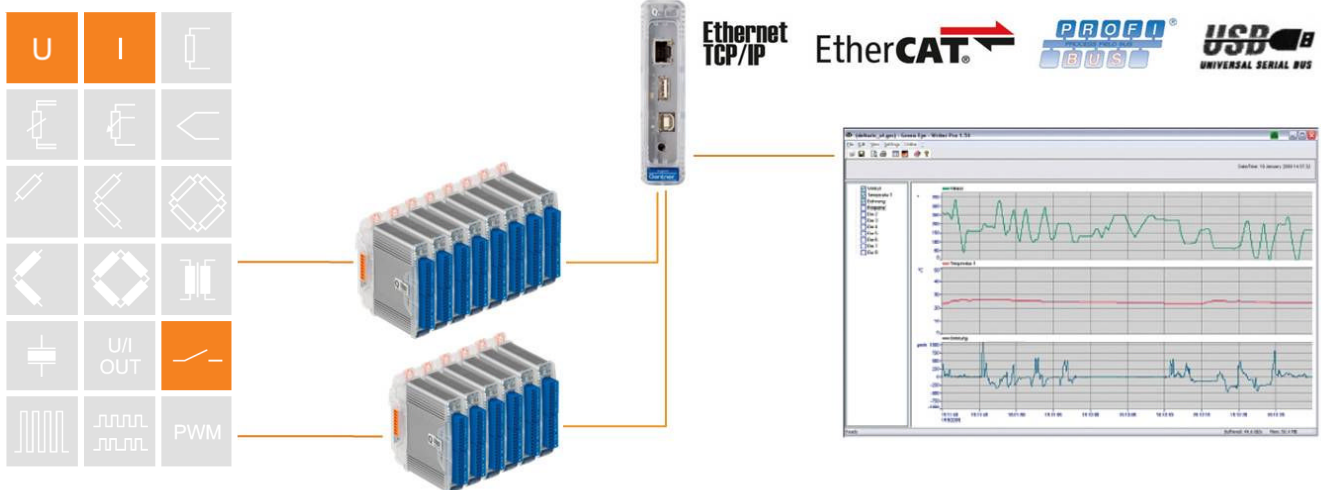



Q.bloxx A108

Multi Channel Module for Dynamic Voltages

Block Diagram

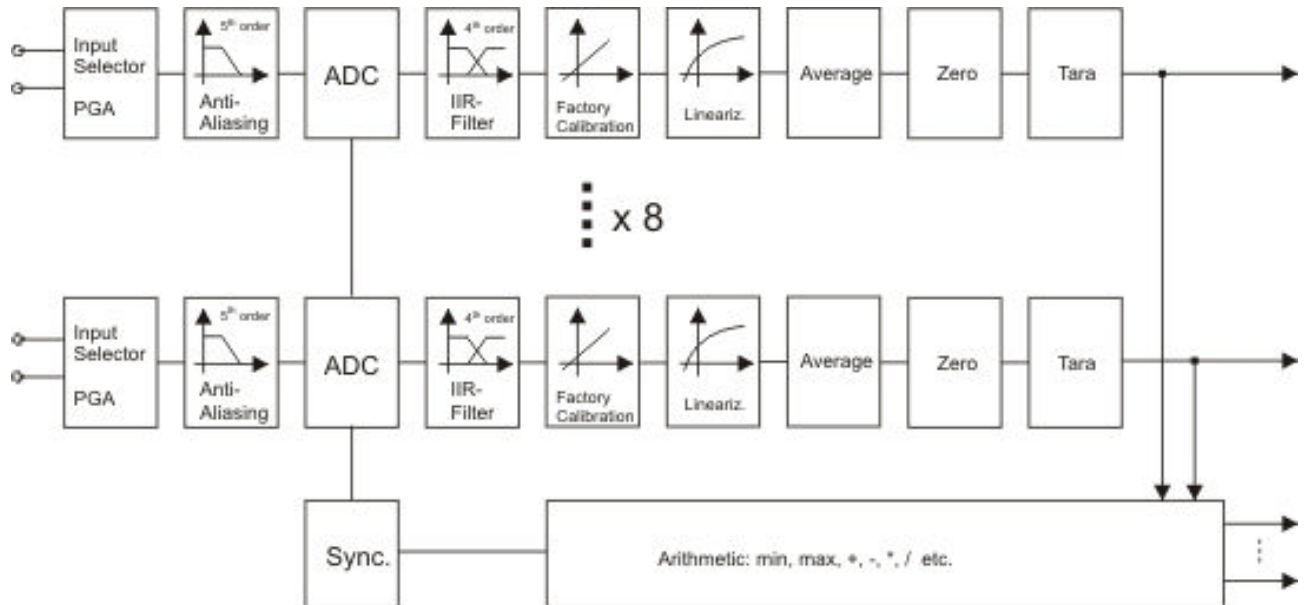

Analog Inputs			
Number	8		
Accuracy	0.01 % typical		
	0.02 % in controlled environment ¹		
	0.05 % in industrial area ²		
Linearity error	0.01 % of the final value typical		
Repeatability	0.003 % typical (within 24 h)		
Isolation voltage	500 VDC channel to channel to power supply to interface ³		
Measurement Voltage	Range	max. Deviation	Resolution
	±10 V	±3 mV	40 µV
Input resistance	>1 MΩ		
Long term drift	<100 µV / 24 h; <250 µV / 8000 h		
Temperature influence	on zero		on sensitivity
	<50 µV / 10 K		<0.05 % / 10 K
Signal-noise-ratio	>100 dB at 100 Hz	>120 dB at 1 Hz	

¹ according EN 61326: 1997, appendix B

² according EN 61326: 1997, appendix A

³ noise pulses up to 1000 VDC, permanent up to 250 VDC



Q.bloxx A108

Multi Channel Module for Dynamic Voltages

Analog/Digital-Conversion	
Resolution	24 bit
Sample rate	10 kHz at 8 active channels
Conversion method	Sigma-Delta (group delay time 600 µs)
Anti-aliasing filter	2 kHz, 5 th order
Digital filter	IIR, low pass, high pass, band pass, 4 th order, 1 Hz up to 1 kHz in steps 1, 2, 5
Averaging	configurable or automated according the selected data rate
Digital In/Outputs	
Number	4, 2 digital inputs, 2 digital outputs
Input	state, tare, reset
Input voltage	max. 30 VDC
Input current	max. 0,5 mA
Upper threshold	>10 V (high)
Lower threshold	<2.0 V (low)
Output	state, alarm
Contact	open drain p-channel MOSFET
Load	30 VDC/100 mA (ohmic load)
Power Supply	
Power supply	10 up to 30 VDC, overvoltage and overload protection
Power consumption	approx. 2 W
Influence of the voltage	<0.001 %/V
Environmental	
Operating temperature	-20°C up to +60°C
Storage temperature	-40°C up to +85°C
Relative humidity	5 % up to 95 % at 50°C, non condensing
Communication Interface	
Standard	RS-485, 2-wire
Data format	8e1
Protocols	Local-Bus: 115200 bps up to 48 Mbps Modbus-RTU, ASCII: 19200 bps up to 115200 bps
Connectable devices	max. 32



Q.bloxx A108

Multi Channel Module for Dynamic Voltages

Mechanical	
Case	Aluminum and ABS
Dimensions (W x H x D)	(27 x 120 x 105) mm
Weight	approx. 200 g
Mounting	DIN EN-rail

Warm Up Time

All declarations are valid after a warm up time of 45 minutes.

Valid from January 2011. Specification subject to change without notice
DB_Q.bloxx_A108_E_20.docx