

DDI 222

Dosing pump

Ⓜ Installation and operating instructions



Declaration of Conformity

We **Grundfos Alldos** declare under our sole responsibility that the products **DDI 222**, to which this declaration relates, are in conformity with the Council Directives on the approximation of the laws of the EC Member States relating to

- Machinery (98/37/EC).
Standards used: EN ISO 12100 and EN 809: 1998.
- Electromagnetic compatibility (89/336/EEC).
Standards used:
EN 61000-3-2: 1995 + A1 + A2: 1998,
EN 61000-3-3: 1995,
EN 61326: 1997 + A1: 1998 + A2: 2001 Class B,
EN 61326: 1997 / A1: 1998 + A2: 2001.
- Electrical equipment designed for use within certain voltage limits (73/23/EEC) [95].
Standard used: EN 61010-1: 2002.

Pfinztal, 15th November 2007

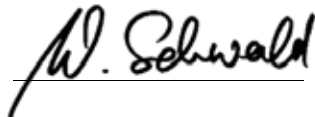

W. Schwald
Managing Director

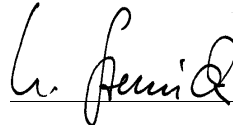

Ulrich Stemick
Technical Director

CONTENTS

	Page		Page
1. General information	3	10. Maintenance	44
1.1 Introduction	3	10.1 General notes	44
1.2 Service documentation	3	10.2 Maintenance intervals	44
1.3 Information about the product	3	10.3 Cleaning suction and discharge valves	44
1.4 Applications	5	10.4 Replacing the diaphragm	45
1.5 Warranty	5	11. Fault finding chart	46
2. Safety	5	12. Disposal	47
2.1 Identification of safety instructions in this manual	5		
2.2 Qualification and training of personnel	5		
2.3 Risks when safety instructions are not observed	5		
2.4 Safety-conscious working	6		
2.5 Safety instructions for the operator/user	6		
2.6 Safety instructions for maintenance, inspection and installation work	6		
2.7 Unauthorised modification and manufacture of spare parts	6		
2.8 Improper operating methods	6		
2.9 Safety of the system in the event of a failure in the dosing system	6		
3. Transport and intermediate storage	6		
3.1 Transport	6		
3.2 Delivery	6		
3.3 Unpacking	6		
3.4 Intermediate storage	6		
3.5 Return	6		
4. Technical data	7		
4.1 Identification	7		
4.2 Type key	8		
4.3 General description	9		
4.4 Safety functions	9		
4.5 Dimensional sketches	10		
4.6 Weight	10		
4.7 Materials	10		
4.8 Control unit	11		
5. Installation	11		
5.1 General information on installation	11		
5.2 Installation location	11		
5.3 Mounting	11		
5.4 Installation examples	12		
5.5 Tube / pipe lines	13		
6. Electrical connections	15		
6.1 Connecting the signal lines for DDI 222	15		
6.2 Connecting the power supply cable	17		
7. Start-up / shutdown	17		
7.1 Initial start-up / subsequent start-up	17		
7.2 Operating the pump	17		
7.3 Shutdown	17		
8. Operation	18		
8.1 Control and display elements	18		
8.2 Switching on/off	18		
9. How to use the control unit	18		
9.1 Menu levels	18		
9.2 General functions of the control unit	18		
9.3 Signal outputs	20		
9.4 First function level	21		
9.5 Second function level	22		
9.6 Calibration	26		
9.7 Service level	28		
9.8 Resetting to default settings	30		
9.9 Current signal control 0-20 mA / 4-20 mA	30		
9.10 Flow Monitor	34		
9.11 Batch menu / batch mode	39		
9.12 Timer menu / timer mode	40		
9.13 Creating a master/slave application	41		
9.14 Hotkeys / info keys	42		
9.15 Pump safety functions	43		

Warning



These complete installation and operating instructions are also available on www.Grundfosalldos.com.

Prior to installation, read these installation and operating instructions. Installation and operation must comply with local regulations and accepted codes of good practice.

1. General information

1.1 Introduction

These installation and operating instructions contain all the information required for starting up and handling the DDI 222 diaphragm dosing pump.

If you require further information or if any problems arise, which are not described in detail in this manual, please contact the nearest Grundfos Alldos company.

1.2 Service documentation

If you have any questions, please contact the nearest Grundfos Alldos company or service workshop.

1.3 Information about the product

1.3.1 Pump types

The DDI 222 dosing pump is available for a variety of performance ranges in various sizes:

Pump types

DDI 60-10

DDI 150-4

The following is indicated on the pump nameplate (see section [4.1 Identification](#)):

- The pump type which specifies the stroke volume, connection size and performance data (see below).
- The pump serial number which is used to identify the pump.
- The most important characteristics of the pump configuration, e.g. dosing head and valve materials. They are described in section [4.2 Type key](#).
- Maximum flow rate and maximum counter-pressure.
- Supply voltage or mains voltage and mains frequency.

Note

The pump for viscous liquids is called HV variant in the following.

1.3.2 Connection size

Pump type	Connection size	HV variant
DDI 60-10	DN 8	DN 20
DDI 150-4	DN 20	DN 20

1.3.3 Pump performance

Performance data at maximum pump counter-pressure

Pump type	Normal operation			Slow-mode operation			Slow-mode-2 operation		
	Q**	p max.*	Max. stroke rate	Q**	p max.*	Max. stroke rate	Q**	p max.*	Max. stroke rate
	[l/h]	[bar]	[n/min]	[l/h]	[bar]	[n/min]	[l/h]	[bar]	[n/min]
DDI 60-10	60	10	180	40	10	120	24.7	10	74
DDI 150-4	150	4	180	100	4	120	62	4	74

* Observe the maximum permissible temperatures and that the friction loss increases with the viscosity of the dosing medium.

** The maximum dosing flow of HV-variant pumps is up to 10 % lower.

Note *The pump can be operated in the range between 0.125 % and 100 % of the maximum dosing capacity.*

Note *The maximum display indication is higher than the nominal capacity of the pump because it refers to the default setting.*

1.3.4 Accuracy

- Applies to:
 - water as dosing medium
 - fully deaerated dosing head
 - standard pump version.
- Dosing flow fluctuation and linearity deviation: ± 1.5 % of the full-scale value.
- Construction tolerance: according to VDMA 24284.

1.3.5 Inlet pressure and counter-pressure / suction lift during operation

Maximum inlet pressure

Pump type	Operating conditions / version
	All*
	[bar]
DDI 60-10 - DDI 150-4	2

* For pumps with pressure sensor (Flow Monitor pump option), the inlet pressure on the suction side must not exceed 1 bar.

Minimum counter-pressure at the pump discharge valve

Pump type	Operating conditions / version
	All*
	[bar]
DDI 60-10 - DDI 150-4	1

* For pumps with pressure sensor (Flow Monitor pump option), the minimum system pressure is 2 bar and the minimum pressure difference between the suction and discharge sides is 2 bar. If the volume flow is not constant (as, for example, in the case of contact or analog control), even small volume flows should not fall below the minimum pressure or the minimum pressure difference.

Maximum suction lift* (start-up) for media with a viscosity similar to water

Pump type	Operating conditions / version
	Continuous operation
	[m]
DDI 60-10 - DDI 150-4	1

* Deaeration valve open.

Maximum suction lift* (continuous operation) for non-degassing media with a viscosity similar to water

Pump type	Operating conditions / version
	Normal operation
	[m]
DDI 60-10	6
DDI 150-4	3

* Dosing head and valves filled with dosing medium.

1.3.6 Sound pressure level

65 dB(A), testing according to DIN 45635-01-KL3.

1.3.7 Enclosure class

Caution *The enclosure class is only met if the sockets are protected! The data regarding the enclosure class applies to pumps with correctly inserted plugs or screwed-on caps.*

- Pump with mains plug: IP 65.
- Pump without mains plug: IP 65 can only be ensured if the power supply cable is connected with IP 65 protection.

1.3.8 Required energy

Power supply for AC voltage

- Rated voltage range: 110-240 V.
Deviation from the rated value: ± 10 %.
- Mains frequency: 50/60 Hz.
- Maximum input power: 50 W including all sensors (reduced input power according to pump type and connected sensors).

Note *The power supply must be electrically isolated from the signal inputs and outputs.*

1.3.9 Ambient and operating conditions

- Permissible ambient temperature: 0 °C to +40 °C.
- Permissible storage temperature: -10 °C to +50 °C.
- Permissible air humidity: max. relative humidity: 92 % (non-condensing).



Warning

The DDI 222 is NOT approved for operation in potentially explosive areas!

The installation site must be under cover! Ensure that the enclosure class of motor and pump is not affected by the atmospheric conditions.

Caution

Pumps with electronics are only suitable for indoor use! Do not install outdoors!

1.3.10 Dosing medium

Caution *In the event of questions regarding the material resistance and suitability of the pump for specific dosing media, please contact Grundfos Alldos.*

The dosing medium must have the following basic characteristics:

- liquid
- non-abrasive
- non-inflammable.

Maximum permissible viscosity at operating temperature*

Pump type	Maximum viscosity*		
	Normal operation	Slow-mode-1 operation	Slow-mode-2 operation
	[mPa s]	[mPa s]	[mPa s]
Standard			
DDI 60-10	100	200	500
DDI 150-4	100	200	500
Standard with Flow Monitor			
DDI 60-10	70	100	200
DDI 150-4	50	100	200
HV variant with/without Flow Monitor			
DDI 60-10	1200	2000	3000
DDI 150-4	700	1200	1800

* The stated values are approximate values and apply to Newtonian liquids.

Note that the viscosity increases with decreasing temperature!

Permissible media temperature

Dosing head material	Min. media temperature	Max. media temperature
	p < 10 bar	
	[°C]	[°C]
PVC	0	40
Stainless steel, DIN 1.4571*	-10	70
PP	0	40
PVDF**	-10	60*

* A temperature of 120 °C at a counter-pressure of max. 2 bar is permitted for a short period (15 minutes).

** At 70 °C, the maximum counter-pressure is 3 bar.



Warning

Observe the chemical manufacturer's safety instructions when handling chemicals!

Caution

The dosing medium must be in liquid form!

Observe the freezing and boiling points of the dosing medium!

The resistance of the parts that come into contact with the media depends on the media, media temperature and operating pressure. Ensure that parts in contact with the media are chemically resistant to the dosing medium under operating conditions!

Caution

Make sure that the pump is suitable for the actual dosing medium!

1.4 Applications

1.4.1 Appropriate, acceptable and correct usage

The DDI 222 pump is suitable for liquid, non-abrasive and non-inflammable media strictly in accordance with the instructions in this manual.

Warning



Other applications or the operation of pumps in ambient and operating conditions, which are not approved, are considered improper and are not permitted. Grundfos Alldos accepts no liability for any damage resulting from incorrect use.

1.5 Warranty

Warranty in accordance with our general terms of sale and delivery is only valid

- if the pump is used in accordance with the information within this manual.
- if the pump is not dismantled or incorrectly handled.
- if repairs are carried out by authorised and qualified personnel.
- if original spare parts are used for repairs.

2. Safety

This manual contains general instructions that must be observed during installation, operation and maintenance of the pump. This manual must therefore be read by the installation engineer and the relevant qualified personnel/operators prior to installation and start-up, and must be available at the installation location of the pump at all times.

It is not only the general safety instructions given in this "Safety" section that must be observed, but also all the specific safety instructions given in other sections.

2.1 Identification of safety instructions in this manual

If the safety instructions or other advice in this manual are not observed, it may result in personal injury or malfunction and damage to the pump. The safety instructions and other advice are identified by the following symbols:



Warning

If these safety instructions are not observed, it may result in personal injury!

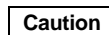

Caution

If these safety instructions are not observed, it may result in malfunction or damage to the equipment!

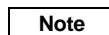

Note

Notes or instructions that make the job easier and ensure safe operation.

Information provided directly on the pump, e.g. labelling of fluid connections, must be observed and must be maintained in a readable condition at all times.

2.2 Qualification and training of personnel

The personnel responsible for the operation, maintenance, inspection and installation must be appropriately qualified for these tasks. Areas of responsibility, levels of authority and the supervision of the personnel must be precisely defined by the operator.

If the personnel do not have the necessary knowledge, the necessary training and instruction must be given. If necessary, training can be performed by the manufacturer/supplier at the request of the operator of the pump. It is the responsibility of the operator to make sure that the contents of this manual are understood by the personnel.

2.3 Risks when safety instructions are not observed

Non-observance of the safety instructions may have dangerous consequences for the personnel, the environment and the pump. If the safety instructions are not observed, all rights to claims for damages may be lost.

Non-observance of the safety instructions may lead to the following hazards:

- failure of important functions of the pump/system
- failure of specified methods for maintenance
- harm to humans from exposure to electrical, mechanical and chemical influences
- damage to the environment from leakage of harmful substances.

2.4 Safety-conscious working

The safety instructions in this manual, applicable national health and safety regulations and any operator internal working, operating and safety regulations must be observed.

2.5 Safety instructions for the operator/user

Hazardous hot or cold parts on the pump must be protected to prevent accidental contact.

Leakages of dangerous substances (e.g. hot, toxic) must be disposed of in a way that is not harmful to the personnel or the environment. Legal regulations must be observed.

Damage caused by electrical energy must be prevented (for more details, see for example the regulations of the VDE and the local electricity supply company).

2.6 Safety instructions for maintenance, inspection and installation work

The operator must ensure that all maintenance, inspection and installation work is carried out by authorised and qualified personnel, who have been adequately trained by reading this manual.

All work on the pump should only be carried out when the pump is stopped. The procedure described in this manual for stopping the pump must be observed.

Pumps or pump units which are used for media that are harmful to health must be decontaminated.

All safety and protective equipment must be immediately restarted or put into operation once work is complete.

Observe the points described in the initial start-up section prior to subsequent start-up.



Warning

Electrical connections must only be carried out by qualified personnel!

The pump housing must only be opened by personnel authorised by Grundfos Alldos!

2.7 Unauthorised modification and manufacture of spare parts

Modification or changes to the pump are only permitted following agreement with the manufacturer. Original spare parts and accessories authorised by the manufacturer are safe to use.

Using other parts can result in liability for any resulting consequences.

2.8 Improper operating methods

The operational safety of the supplied pump is only ensured if it is used in accordance with section 1. *General information*. The specified limit values must under no circumstances be exceeded.

2.9 Safety of the system in the event of a failure in the dosing system

DDI 222 dosing pumps are designed according to the latest technologies and are carefully manufactured and tested. However, a failure may occur in the dosing system. Systems in which dosing pumps are installed must be designed in such a way that the safety of the entire system is still ensured following a failure of the dosing pump. Provide the relevant monitoring and control functions for this.

3. Transport and intermediate storage

3.1 Transport

Caution *Do not throw or drop the pump.*

3.2 Delivery

The DDI 222 dosing pump is delivered in a cardboard box. Place the pump in the packaging during transport and intermediate storage.

3.3 Unpacking

Retain the packaging for future storage or return, or dispose of the packaging in accordance with local regulations.

3.4 Intermediate storage

- Permissible storage temperature: $-10\text{ }^{\circ}\text{C}$ to $+50\text{ }^{\circ}\text{C}$.
- Permissible air humidity: max. relative humidity: 92 % (non-condensing).

3.5 Return

Return the pump in its original packaging or equivalent.

The pump must be thoroughly cleaned before it is returned or stored. It is essential that there are no traces of toxic or hazardous media remaining on the pump.

Caution *Grundfos Alldos accepts no liability for damage caused by incorrect transportation or missing or unsuitable packaging of the pump!*

Before returning the pump to Grundfos Alldos for service, the **safety declaration** at the end of these instructions must be filled in by authorised personnel and attached to the pump in a visible position.

Caution *If a pump has been used for a medium which is injurious to health or toxic, the pump will be classified as contaminated.*

If Grundfos Alldos is requested to service the pump, it must be ensured that the pump is free from substances that can be injurious to health or toxic. If the pump has been used for such substances, the pump must be cleaned before it is returned.

If proper cleaning is not possible, all relevant information about the chemical must be provided.

If the above is not fulfilled, Grundfos Alldos can refuse to accept the pump for service. Possible costs of returning the pump are paid by the customer.

The safety declaration can be found at the end of these instructions.

Caution *The replacement of the power supply cable must be carried out by an authorised Grundfos Alldos service workshop.*

4. Technical data

4.1 Identification

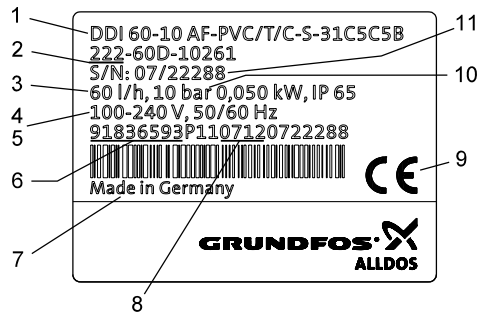

TM03 8687 2207

Fig. 1 DDI 222 nameplate

Pos.	Description
1	Type designation
2	Model
3	Maximum capacity [l/h]
4	Voltage [V]
5	Frequency [Hz]
6	Product number
7	Country of origin
8	Year and week code
9	Marks of approval, CE mark, etc.
10	Maximum pressure [bar]
11	Serial number

4.2 Type key

Example:	DDI	150	- 4	AR	-PP	/E	/G	-S	-3	1	B2	B2	F
Type range													
DDI													
Maximum flow [l/h]													
Maximum counter-pressure [bar]													
Control variant													
AR	Standard												
AF	AR with Flow Monitor												
AP	AR with PROFIBUS												
APF	AR with Flow Monitor and PROFIBUS												
Dosing head variant													
PP	Polypropylene												
PV	PVDF (polyvinylidene fluoride)												
PVC	Polyvinyl chloride												
SS	Stainless steel, DIN 1.4401												
PP-L	PP + integrated diaphragm leakage detection												
PV-L	PV + integrated diaphragm leakage detection												
PVC-L	PVC + integrated diaphragm leakage detection												
SS-L	SS + integrated diaphragm leakage detection												
Gasket material													
E	EPDM (ethylene propylene diene monomer)												
V	FKM												
T	PTFE												
Valve ball material													
C	Ceramics												
G	Glass												
T	PTFE												
SS	Stainless steel, DIN 1.4401												
Control panel position													
F	Front-mounted												
S	Side-mounted												
	Mains plug												
	X No plug												
	F EU (Schuko)												
	B USA, Canada												
	I Australia, New Zealand, Taiwan												
	E Switzerland												
	Connection, suction/discharge												
	4 Tube, 6/9 mm												
	6 Tube, 9/12 mm												
	S Tube, 0.375"/0.5"												
	Q Tube, 19/27 mm												
	B1 Tube 6/12 mm/ cementing d. 12 mm												
	B2 Tube 13/20 mm/ cementing d. 25 mm												
	A Threaded, Rp 1/4, female												
	A1 Threaded, Rp 3/4, female												
	A3 Threaded, 3/4" NPT, female												
	V Threaded, 1/4" NPT, female												
	A9 Threaded, 1/2" NPT, male												
	B3 Welding d. 16 mm												
	B4 Welding d. 25 mm												
	Valve type												
	1 Standard												
	Spring-loaded												
	2 0.05 bar suction opening pressure; 0.05 bar discharge opening pressure												
	5 For abrasive media (stainless steel only)												
	Spring-loaded												
	6 (DN 20, stainless-steel balls) 0.8 bar discharge opening pressure												
	Supply voltage												
	3 1 x 100-240 V, 50/60 Hz												

4.3 General description

The DDI 222 is a dosing pump with an EC motor (brushless DC motor) as the drive and electronic power control. The pump is operated via the diagonal display in a user-friendly menu structure.

The pump incorporates an overpressure safety feature. When an adjustable cut-off pressure is exceeded, the pump can be switched off automatically.

The DDI 222 is available in various versions. See also section 1. *General information*.

Option:

The pump can also be equipped with the following:

- diaphragm leakage sensor (MLS)
- interface for PROFIBUS.

The functions are described, but only apply to the relevant pump version.

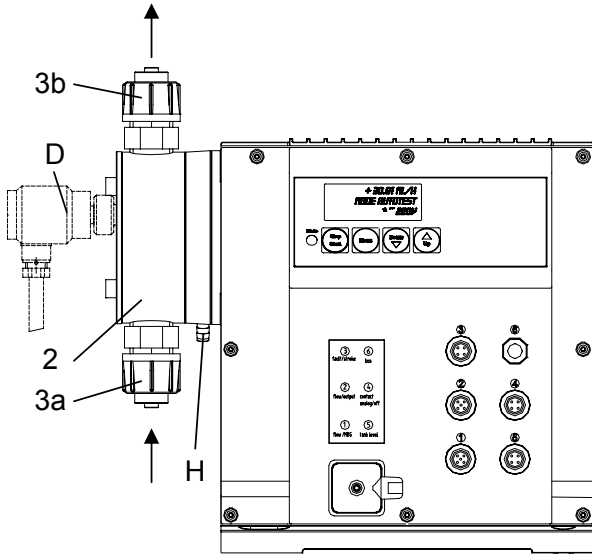

Fig. 2 DDI 222

Pos.	Components
3a	Suction valve
3b	Discharge valve
2	Dosing head
D	MLS pressure switch (optional)
H	Outlet joint in the event of diaphragm leakage

4.3.1 HV variant for liquids which are more viscous than water

All HV-variant pumps are equipped with spring-loaded DN 20 valves with an opening pressure of 0.1 bar (or 0.8 bar for the pressure side) and connection for PVC tube 19 x 27. DDI 60-10 has a special dosing head.

Note

Note that the HV-variant pump has other dimensions than the standard pump and that other connection line dimensions might be required!

4.4 Safety functions

4.4.1 Diaphragm leakage detection (optional)

Pumps with diaphragm leakage signal have a special dosing head with a diaphragm set and pressure switch. The pressure switch (socket 1) is fitted and connected to the pump on delivery.

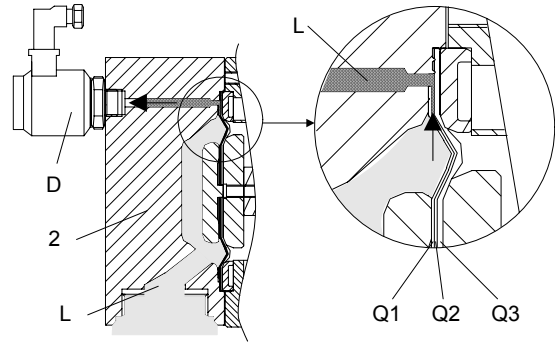

Fig. 3 Dosing head with diaphragm set and pressure switch for diaphragm leakage detection

Pos.	Components
2	Dosing head
D	Pressure switch
Q1	Working diaphragm
Q2	Signal diaphragm (intermediate layer made from fabric)
Q3	Protection diaphragm

In the event of a leak in the diaphragm:

- Dosing medium penetrates between the working diaphragm and the protection diaphragm and is transferred to the pressure switch via the signal diaphragm.
- On the next pressure stroke, pressure is applied to the pressure switch, which is activated. The pump indicates an error but continues operating.
- The electronics operates two contacts, which can be used, for example, to trigger an alarm signal or to switch off the pump.
- In emergency mode, the pump can continue operating for a short time.

After a diaphragm leakage detection, the pressure switch has to be checked. In case the diaphragm of the pressure switch is broken or affected by the dosing liquid, the pressure switch must be replaced.

Caution

4.4.2 Pressure control

The DDI 222 pump incorporates a pressure control function. The pressure is calculated from the motor current consumption or is measured directly in the dosing head if a pressure sensor is present (Flow Monitor pump option). At a user-defined pressure, the pump is switched off automatically.

Caution

To protect the pump and system against excessive pressure build-up, install an overflow valve in the discharge line.

This function protects the pump, but not the system. It is recommended that the system is protected by an overflow valve. This function can be enabled and disabled in the second function level of the electronics.

4.4.3 Dosing control (Flow Monitor)

The pressure sensor (Flow Monitor pump option) is used as a dosing controller and to monitor the pressure for the whole power ranges.

The Flow Monitor for dosing control consists of a pressure sensor integrated in the dosing head.

The pressure sensor is available as Flow Monitor pump option. The pressure sensor is fitted to the pump on delivery. Upgrades are not possible.

Note

Pressure control is primarily used to protect the pump. This function is not a substitute for the overflow valve.

4.4.4 Flow compensation

The flow compensation is a function to keep the dosing flow constant with changing system pressure. Pressure changes are detected by the pressure sensor and the motor speed is adjusted accordingly.

To use this function, pressure control or dosing control (Flow Monitor) has to be activated in the electronics.

When dosing media with a viscosity similar to water, the pump needs not to be calibrated, as the pump already responds to the possible change of the system pressure.

When dosing media with a viscosity different from water or after a software update, the pump has to be calibrated.

Note

4.5 Dimensional sketches

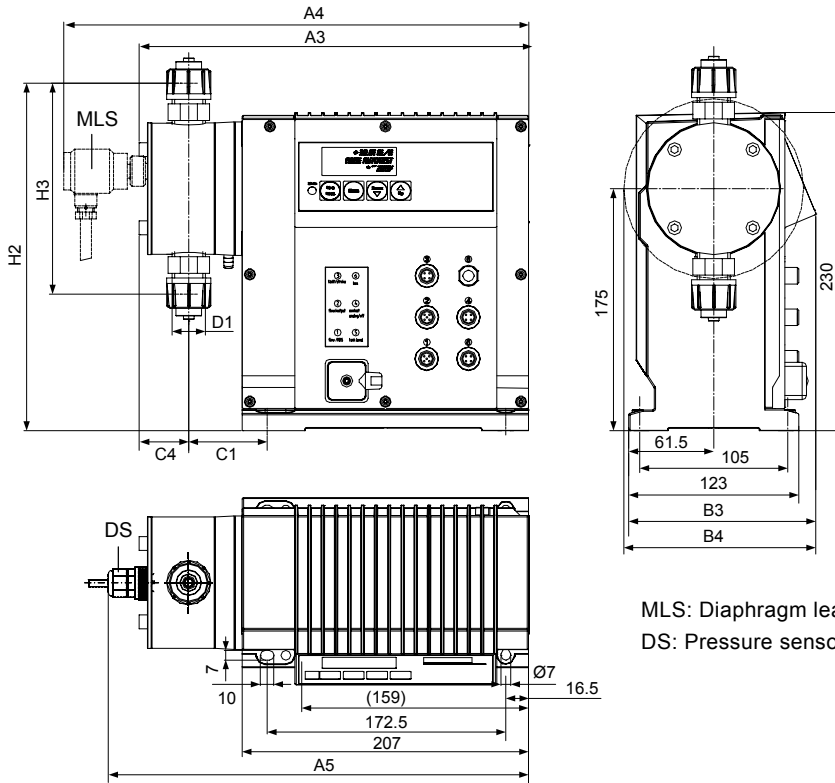

MLS: Diaphragm leakage sensor (optional)
DS: Pressure sensor (Flow Monitor pump option)

Fig. 4 DDI 222

Dimensions for DDI 222

	A3 [mm]	A4 [mm]	A5 [mm]	B3 [mm]	B4 [mm]	C1 [mm]	C4 [mm]	D1	H2 [mm]	H3 [mm]
DDI 60-10	283	338	306	137	–	58	37	R 5/8	252	153
DDI 150-4	315	372	350	137	139	90	39	R 1 1/4	265	179
DDI 60-10 / HV	295	350	328	137	–	68	38	R 1 1/4	246	143
DDI 150-4 / HV	315	372	350	137	139	90	39	R 1 1/4	265	179

4.6 Weight

Pump type	Dosing head material	Weight [kg]
DDI 60-10	PVC, PP, PVDF	5
DDI 60-10	Stainless steel, DIN 1.4571	7
DDI 150-4	PVC, PP, PVDF	6.5
DDI 150-4	Stainless steel, DIN 1.4571	12

4.7 Materials

Pump housing material

Pump and control unit housing: PPE-SB (fibre-reinforced Lurranyl).

Pressure sensor (Flow Monitor)

Sensor: Aluminium oxide Al₂O₃ (96 %).

O-rings: FKM, EPDM or PTFE.

Pressure switch (MLS)

Pressure switch: Stainless steel, DIN 1.4305.

Diaphragm of the pressure switch: EPDM.



Warning

Observe the manufacturer's safety instructions when handling chemicals!

The resistance of the parts that come into contact with the media depends on the media, media temperature and operating pressure. Ensure that parts in contact with the media are chemically resistant to the dosing medium under operating conditions!

Caution

Note

Further information on resistance with regard to the media, media temperature and operating pressure is available on request.

TM03 6663 4506

4.8 Control unit

Functions of pumps with control unit

- "continuous operation" button for function test and suction
- memory function (stores a maximum of 65,000 pulses)
- two-stage tank-empty signal (e.g. via Grundfos Alldos tank-empty sensor)
- stroke/pulse signal / pre-empty signal (adjustable)
- dosing controller or Flow Monitor function (only with sensor – optional)
- diaphragm leakage detection (only with sensor – optional)
- access-code-protected settings
- remote on/off
- calibration (adjust the pump to local operating conditions)
- pressure control function / counter-pressure display
- dosing capacity display (can be reset)
- operating hours counter (cannot be reset)
- interface: PROFIBUS (optional).

Operating modes:

- manual
input/display of the dosing flow in l/h or gal/h.
Quasi continuous dosing (short suction stroke, dosing stroke as long as possible).
- contact signal control
input/display in ml/contact, most constant dosing
- current signal control 0-20 mA / 4-20 mA
Adjustment of volumetric flow proportional to the current signal (displayed in l/h).
Weighting of current input/output.
- batch dosing
Setting the dosing capacity and dosing flow per batch triggered manually or by an external contact signal.
- batch dosing with timer functions
 - setting the dosing capacity and dosing flow per batch
 - setting the start time for first batch
 - setting the repeat time for subsequent batches.
- slow mode (for viscous media)
two-stage reduction of the maximum dosing flow to 66 % (slow mode 1) or 41 % (slow mode 2).

Inputs and outputs

Inputs	
Contact signal	Maximum load: 12 V, 5 mA Minimum pulse length: 10 ms Minimum pause time: 25 ms
Current 0-20 mA	Maximum load: 22 Ω
Remote on/off	Maximum load: 12 V, 5 mA
Tank-empty signal	Maximum load: 12 V, 5 mA
Dosing controller and diaphragm leakage sensor	
Outputs	
Current 0-20 mA	Maximum load: 350 Ω
Error signal	Maximum ohmic load: 50 V DC / 75 VAC, 0.5 A
Stroke signal	Contact time/stroke: 200 ms
Pre-empty signal	Maximum ohmic load: 50 V DC / 75 VAC, 0.5 A

4.8.1 Interface (optional)

- PROFIBUS.

5. Installation

5.1 General information on installation



Warning

Observe the specifications for the range of applications and installation location described in sections 1. General information and 5.2 Installation location.

Warning

Faults, incorrect operation or faults on the pump or system can, for example, lead to excessive or insufficient dosing, or the permissible pressure may be exceeded. Consequential faults or damage must be evaluated by the operator and appropriate precautions must be taken to avoid them!



5.2 Installation location

5.2.1 Space required for operation and maintenance

Note

The pump must be installed in a position where it is easily accessible during operation and maintenance work.

The control elements must be easily accessible during operation. Maintenance work on the dosing head and the valves must be carried out regularly.

Provide sufficient space for removing the dosing head and the valves.

5.2.2 Permissible ambient influences

Permissible ambient temperature: 0 °C to +40 °C.

Permissible air humidity: max. relative humidity: 92 % (non-condensing).

The installation site must be under cover!
Ensure that the enclosure class of motor and pump is not affected by the atmospheric conditions.

Caution

Pumps with electronics are only suitable for indoor use! Do not install outdoors!

5.2.3 Mounting surface

The pump must be mounted on a flat surface.

5.3 Mounting

Caution

Carefully tighten the screws, otherwise the plastic housing may be damaged.

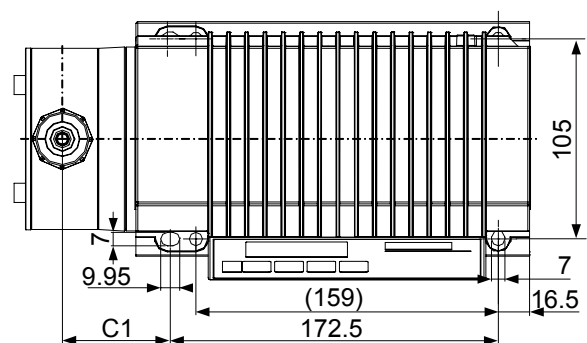

Fig. 5 Drilling scheme

- Use four M6 screws to mount the pump on the tank or on a console so that the suction valve is at the bottom and the discharge valve is at the top (dosing always flows upwards).

5.4 Installation examples

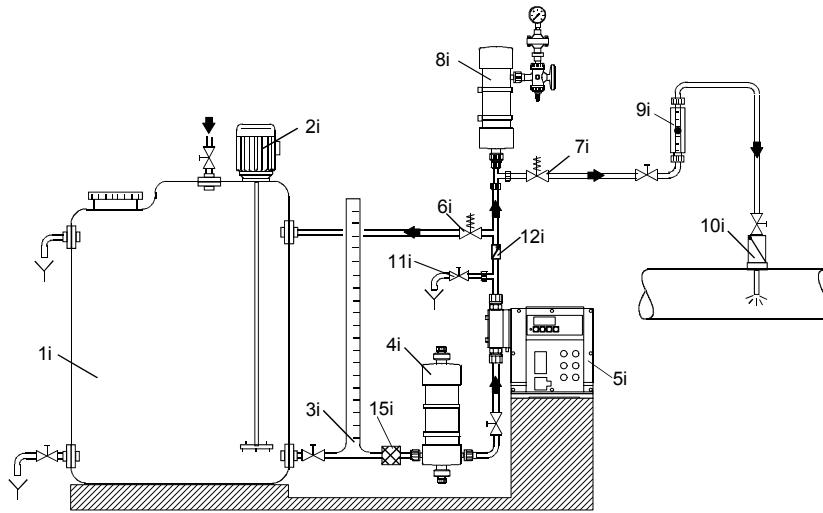

Fig. 6 Installation example of pump with manual deaeration

Pos.	Components
1i	Dosing tank
2i	Electric agitator
3i	Extraction device
4i	Suction pulsation damper
5i	Dosing pump
6i	Relief valve
7i	Pressure-loading valve
8i	Pulsation damper
9i	Calibration tube
10i	Injection unit
11i	Deaeration and evacuation valve
12i	Check-back valve
15i	Filter

5.4.1 Installation tips

- For non-degassing media with a viscosity similar to water, the pump can be mounted on the tank (observe the permissible suction lift).
- Flooded suction preferred.
- For media with a tendency to sedimentation, install the suction line with filter (15i) so that the suction valve remains a few millimetres above the possible level of sedimentation.

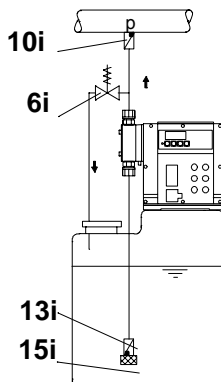

Fig. 7 Tank installation

With open outflow of the dosing medium or low counter-pressure

A positive pressure difference of at least 1 bar must be ensured between the counter-pressure at the injection point and the pressure of the dosing medium at the pump suction valve.

- If this cannot be ensured, install a pressure-loading valve (7i) immediately before the outlet or the injection unit.

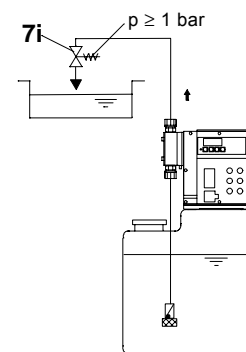

Fig. 8 Installation with pressure-loading valve

- To avoid the siphon effect, install a pressure-loading valve (7i) in the discharge line and, if necessary, a solenoid valve (14i) in the suction line.

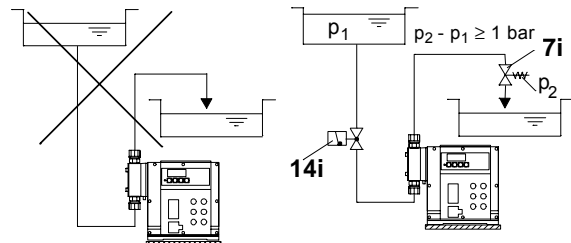

Fig. 9 Installation to avoid the siphon effect

- To protect the dosing pump against excessive pressure build-up, install a relief valve (6i) in the discharge line.
- For degassing media:
 - Flooded suction.
 - Install a filter (15i) in the suction line to prevent the valves being contaminated.

TM03 6666 4506

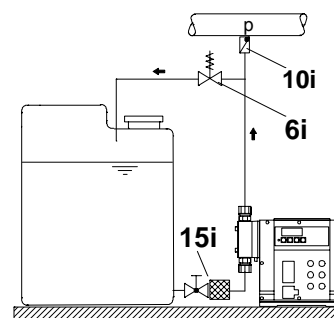

Fig. 10 Installation with relief valve and filter

TM03 6665 4506

TM03 6667 4506

TM03 6668 4506

TM03 6669 4506

- For line lengths above 1 metre a suction pulsation damper (4i) may be required, depending on the flow rate.

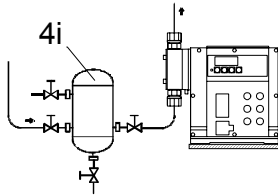

Fig. 11 Installation with suction pulsation damper

TM03 6670 4506

- For damper and line lengths above 3 metres and for flexible pipework and line lengths above 5 metres, a pulsation damper (8i) must be used to protect the system.

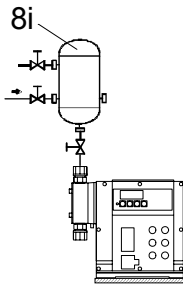

Fig. 12 Installation with pulsation damper

TM03 6671 4506

- When installing the suction line, observe the following:
 - Keep the suction line as short as possible. Prevent it from becoming tangled.
 - If necessary, use swept bends instead of elbows.
 - Always route the suction line up towards the suction valve.
 - Avoid loops as they may cause air bubbles.

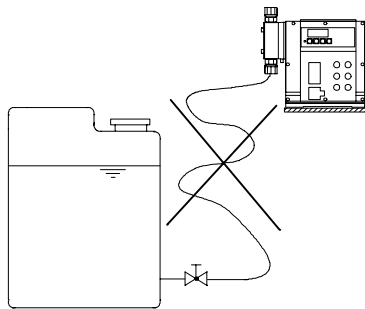

Fig. 13 Installation of suction line

TM03 6672 4506

- In the case of long discharge lines, install a non-return valve (12i) in the discharge line.

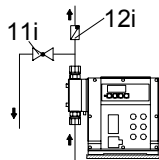

Fig. 14 Installation with non-return valve

TM03 6673 4506

5.5 Tube / pipe lines

5.5.1 General

Warning

To protect the dosing pump against excessive pressure build-up, install a relief valve in the discharge line.



All lines must be free from strain!
Avoid loops and buckles in the tubes!
Keep the suction line as short as possible!
The flow must run in the opposite direction to gravity!

Observe the manufacturer's safety instructions when handling chemicals!

The resistance of the parts that come into contact with the media depends on the media, media temperature and operating pressure. Ensure that parts in contact with the media are chemically resistant to the dosing medium under operating conditions!

Caution

Only use the specified line types!

Maximum suction line length

- 5 m for standard pumps when dosing media with a viscosity similar to water and using a pulsation damper.
- 1.2 m when dosing media with a higher viscosity than water.
- 1.2 m for pumps with Flow Monitor (2 m for standard DDI 60-10) when dosing media with a viscosity similar to water and not using a pulsation damper.

5.5.2 Sizing of tube / pipe lines

Warning

Observe the pressure stage of the used lines. The maximum permissible inlet pressure and the pressure stage of the discharge lines must not be exceeded!



Minimum internal diameter

Pump type	Pump version	
	Standard [mm]	HV variant [mm]
DDI 60-10	Suction side: 9 Discharge side: 6	Suction side: 19 Discharge side: 13
DDI 150-4	13	Suction side: 19 Discharge side: 13

5.5.3 Connecting the suction and discharge lines

- Connect the suction line to the suction valve (3a).
 - Install the suction line in the tank so that the foot valve remains approximately 5 to 10 mm above the bottom of the tank or the possible level of sedimentation.
- Connect the discharge line to the discharge valve (3b).

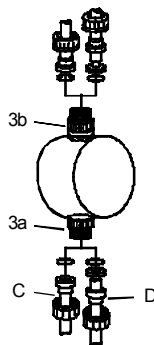

TM03 6235 4506

Fig. 15 Connecting the suction and discharge lines

Pos.	Components
3a	Suction valve
3b	Discharge valve
C	Pipe connection
D	Tube connection

Caution

Observe the pressure limits specified in section 1. General information!

6. Electrical connections

Make sure that the pump is suitable for the electricity supply on which it will be used.



Warning

Electrical connections must only be carried out by qualified personnel!
Disconnect the power supply before connecting the power supply cable and the relay contacts!
Observe the local safety regulations!



Warning

The pump housing must only be opened by personnel authorised by Grundfos Aallos!



Warning

Protect the cable connections and plugs against corrosion and humidity.
Only remove the protective caps from the sockets that are being used.

Caution

The power supply must be electrically isolated from the signal inputs and outputs.

6.1 Connecting the signal lines for DDI 222

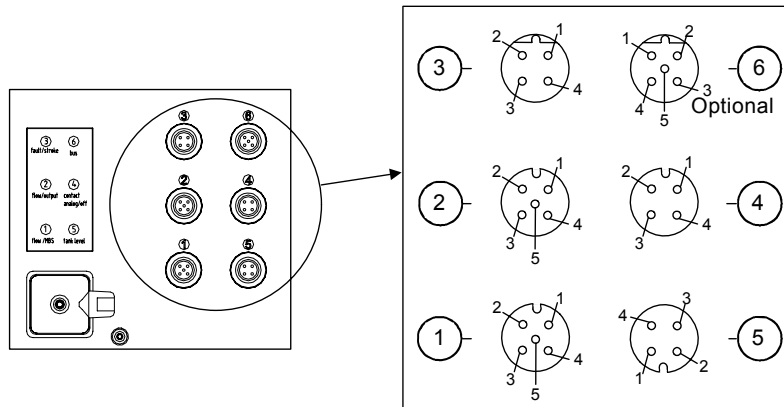

Fig. 16 DDI 222 connection diagram

6.1.1 Diaphragm leakage signal / (pressure sensor – Flow Monitor)

Socket 1

For diaphragm leakage signal (MLS) and/or pressure sensor (Flow Monitor pump option).

The diaphragm leakage signal and pressure sensor are pre-assembled with an M12 plug for socket 1.

- Connect the cables according to the table below.

Socket 1		Used for / wire colours	
Pin	Assignment	Diaphragm leakage signal (MLS)*	Pressure sensor
1	+ 5 V		x
3	Pressure sensor input		x
4	MLS input	Black	
5	GND	Green/yellow	x

* MLS is an abbreviation of the function in German language "Membranleakagesignalisierung" = diaphragm leakage signalling

6.1.2 Current output / Flow Monitor (pressure sensor)

Socket 2

For pressure sensor for Flow Monitor option.

The pressure sensor is supplied ready-made with M12 plug for socket 2 or socket 1.

The current output indicates the current dosing flow and can be weighted independently of the selected operating mode. See section 9.6.4 *Weighting of current input/output*.

Note

Pressure sensor (Flow Monitor):

If socket 2 is also used for current output, the pressure sensor can be either connected to socket 1 or preferably together with the current output to socket 2 using the plug set (product number 96645265 (321-327)), see section 6.1.7 Accessories: cable and plug for DDI 222.

Socket 2		Cable	Used for	
Pin	Assignment	Wire colour	+/- current output	Pressure sensor
1	+ 5 V	Brown		x
3	Pressure sensor input	Blue		x
4	Current output	Black	+	
5	GND	Green/yellow	-	x

6.1.3 Stroke/pulse signal / pre-empty signal / error signal

Socket 3

Electrically isolated output for stroke/pulse signal or pre-empty signal and error signal.

Socket 3		Cable	Used for	
Pin	Assignment	Wire colour	Stroke/pulse signal/ pre-empty signal	Error signal
1	Error signal contact	Brown		x
2	Stroke/pulse signal or pre-empty signal contact	White	x	
3	Stroke/pulse signal or pre-empty signal contact	Blue	x	
4	Error signal contact	Black		x

6.1.4 Remote on/off / contact input / current input

Socket 4

For the remote on/off input and contact input or current input.

If the remote on/off and contact inputs are to be used at the same time, wire 1 is assigned twice.

For the connection of one cable, use a plug adapter with simple cable entry, for the connection of two cables, use a plug adapter with double cable entry, otherwise the protection will be lost!

Caution

Socket 4		Cable	Used for		
Pin	Assignment	Wire colour	Remote on/off input	Contact input	+/- current input
1	GND	Brown	x	x	-
2	Current input	White			+
3	Remote on/off input	Blue	x		
4	Contact input	Black		x	

6.1.5 Empty signal only / pre-empty and empty signal

Socket 5

For the empty signal only or pre-empty and empty signal input.

The suction lines with empty signal or pre-empty and empty signal are pre-assembled with a plug for socket 5.

Socket 5		Used for	
Pin	Assignment	Empty signal	Pre-empty signal
1	Pre-empty signal		x
2	Empty signal	x	
3	GND	x	x

6.1.6 PROFIBUS (optional)

Socket 6

Socket 6 for PROFIBUS is only used when the PROFIBUS option is selected.

For pumps with PROFIBUS option, please refer to the separate "PROFIBUS-DP" manual provided.

6.1.7 Accessories: cable and plug for DDI 222

Description	Product numbers
4-pole M12 plug, suitable for socket 3, with 2 m signal cable	96609017 (321-206)
4-pole M12 plug, suitable for socket 3, with 5 m signal cable	96609019 (321-208)
4-pole M12 plug, suitable for socket 4, with 2 m signal cable	96609014 (321-205)
4-pole M12 plug, suitable for socket 4, with 5 m signal cable	96609016 (321-207)
5-pole M12 plug set, suitable for socket 2, with coupling for pressure sensor (Flow monitor) and 2 m of signal cable for the current output	96645265 (321-327)
5-pole M12 plug, suitable for sockets 1, 2 and 4, screwed, without cable, with double cable entry	96609030 (321-210)
5-pole M12 plug, suitable for sockets 1, 2 and 4, screwed, without cable, with single cable entry	96609031 (321-217)
Extension cable, 5 m with 5-pole coupling for M12 plug	96609032 (321-223)
5-pole M12 plug, suitable for socket 2, with 2 m signal cable	96632921 (321-215)
5-pole M12 plug, suitable for socket 2, with 5 m signal cable	96632922 (321-216)
5-pole M12 plug, angled, suitable for socket 2, with 2 m signal cable	96699697 (321-271)

6.2 Connecting the power supply cable

Warning

Disconnect the power supply before connecting the power supply cable!



Before connecting the power supply cable, check that the rated voltage stated on the pump nameplate corresponds to the local conditions!

Do not make any changes to the power supply cable or plug!

Caution

The pump can be automatically started by connecting the power supply!

Caution

The assignment between the plug-and-socket connection and the pump must be labelled clearly (e.g. by labelling the socket outlet).

- Do not switch on the power supply until you are ready to start the pump.

6.2.1 Versions without mains plug

Warning



The pump must be connected to an external clearly labelled mains switch with a minimum contact gap of 3 mm in all poles.

- Connect the pump to the mains in accordance with local electrical installation regulations.



Warning

IP 65 can only be ensured if the power supply cable is connected with IP 65 protection.

6.2.2 Version with mains plug

- Insert the mains plug in the mains socket.

Warning



The electronic printed circuit board may be live even if the mains voltage is not connected! The printed circuit board may only be replaced by service personnel authorised by Grundfos Alldos.

7. Start-up / shutdown

Warning



**Risk of chemical burns!
Wear protective clothing (gloves and goggles) when working on the dosing head, connections or lines!**

Before each start-up, check the dosing head screws.

After initial start-up and after each time the diaphragm is changed, tighten the dosing head screws.

Caution

After approximately 6-10 operating hours or two days, cross-tighten the dosing head screws using a torque wrench.

Torque: 7 Nm (+ 1 Nm).

7.1 Initial start-up / subsequent start-up

7.1.1 Checks before start-up

- Check that the rated voltage stated on the pump nameplate corresponds to the local conditions!
- Check that all connections are secure and tighten, if necessary.
- Check that the dosing head screws are tightened with the specified torque and tighten, if necessary.
- Check that all electrical connections are correct.

7.1.2 Assisting suction for systems without flooded suction

At the dry suction/discharge valves:

1. Remove the suction line.
2. Hold a small container of water directly next to the suction valve and draw water until the dosing head is full.
3. Reinsert the suction line.

7.1.3 Starting the pump

1. Open the suction and discharge isolating valves, if installed.
 2. Depressurise the system on the discharge side of the pump:
 - Open the system deaeration and evacuation valve.
 3. Let the pump run in continuous operation:
 - Switch on the power supply.
 - Press the "Start/Stop" button and keep it pressed.
 - The pump switches to continuous operation at maximum stroke frequency.
 4. Leave the pump running until the dosing head and the valves are filled with medium and dosing medium flows from the deaeration line on the discharge side.
 5. Close the system deaeration and evacuation valve.
- The pump is now ready for operation.

7.1.4 Tightening dosing head screws

After initial start-up and after each time the diaphragm is changed, tighten the dosing head screws.

Caution

After approximately 6-10 operating hours or two days, cross-tighten the dosing head screws using a torque wrench.

Torque: 7 Nm (+ 1 Nm).

7.2 Operating the pump

To operate the pump, see sections 8. Operation, 9. How to use the control unit and 10. Maintenance and, if necessary, section 11. Fault finding chart.

Note

7.3 Shutdown

Warning

Risk of chemical burns!



Wear protective clothing (gloves and goggles) when working on the dosing head, connections or lines!

Do not allow any chemicals to leak from the pump. Collect and dispose of all chemicals correctly!

Note

If possible, rinse the dosing head before shutting down the pump, e.g. by supplying it with water.

7.3.1 Switching off / uninstalling

1. Switch off the pump and disconnect it from the power supply.
2. Depressurise the system.
3. Take suitable steps to ensure that the returning dosing medium is safely collected.
4. Carefully remove all lines.
5. Uninstall the pump.

7.3.2 Cleaning

1. Rinse all parts that have come into contact with the medium very carefully:
 - lines
 - valves
 - dosing head
 - diaphragm.
2. Remove any trace of chemicals from the pump housing.

7.3.3 Storage

Storage of the pump:

1. After cleaning (see above), carefully dry all parts and reinstall the dosing head and valves, or
2. change the valves and diaphragm.

See section 10. *Maintenance*.

7.3.4 Disposal

Disposal of the pump:

- After cleaning (see above), dispose of the pump in accordance with the relevant regulations.

8. Operation

In the event of a diaphragm leakage, the dosing liquid may leak out of the hole in the intermediate flange between the pump and the dosing head. The parts inside the housing are protected from the dosing liquid for a short time (depending on the type of liquid) by the housing sealing. It is necessary to check regularly (daily) if liquid is leaking out of the intermediate flange.

Caution



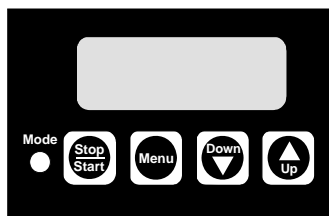

For maximum safety, we recommend the pump version with diaphragm leakage detection.

8.1 Control and display elements



TM03 6257 4506

Fig. 17 Display of DDI 222

Element	Description
	<p>Light-emitting diode (LED)</p> <ul style="list-style-type: none"> • Lights up red when the pump is stopped. • Lights up green when the pump is started and briefly goes out during a suction stroke. • Lights up yellow when the pump is switched off remotely. • Flashes red if an error signal is present. • Flashes red/green when an error message is present and the pump is running, or restarts automatically after the error has been corrected. • Goes out when the pump is in menu mode.
	<p>"Start/Stop"</p> <ul style="list-style-type: none"> • Use this button to start or stop the pump. • Error signals can be acknowledged by pressing the "Start/Stop" button.
	<p>Use the "Menu/Info" button to switch between the operating modes.</p>
 	<p>Use the "Down" and "Up" buttons to change values in the display.</p>

8.1.1 Display test

A display test is automatically performed when the pump is switched on. All the segments of the LCD are switched on for 3 seconds and the software version number is then displayed for 2 seconds.

8.1.2 Display indicator

When switched on (if the pump was stopped) and during pump operation, the dosing flow setpoint is displayed. With contact control the set ml/contact value is displayed.

8.2 Switching on/off

Caution *Before switching on the pump, check that it is installed correctly. See sections 5. Installation and 7.1 Initial start-up / subsequent start-up.*

- To start the pump, switch on the power supply.
- To stop the pump, switch off the power supply.

9. How to use the control unit

Note *First see sections 5. Installation, 7. Start-up / shutdown and 7.2 Operating the pump. Only the additional functions are described in this section.*

9.1 Menu levels

Menu levels used in the control unit

- **First function level:** for selecting and setting the operating modes of the pump (Manual, Contact, Analog), performing the batch and timer functions and starting the pump.
- **Second function level:** for setting and viewing additional functions, selecting and setting the batch and timer functions and setting the access code to protect the pump against unintentional or unauthorised access to pump settings.
- **Service level:** for setting the pump type and the unit of display for the dosing flow (l/h or gal/h) and setting the inputs and outputs.

Saving user settings

The pump settings are automatically saved approximately every 10 minutes and remain as they are even after the power supply has been switched off.

9.2 General functions of the control unit

9.2.1 Suction

If the "Start/Stop" button is pressed for longer than 1 second, the pump switches to continuous operation for as long as the button is held down (e.g. for suction).

This happens regardless of the selected operating mode. (In batch or timer mode, the pump has to be stopped first.)

9.2.2 Locking "run"

The pump can be locked to avoid manual stopping.

When activating this function (service level), the pump starts running with the present settings and cannot be stopped using the "Start/Stop" button.

It is still possible to acknowledge error messages using the "Start/Stop" button.

Stopping the pump when the locking "run" is activated

- If remote on/off is connected, use remote off.
- Disconnect the pump from the power supply.

Note *For "Batch manual", the "Run" button should not be locked as the pump then runs in continuous operation.*

9.2.3 Two-stage tank-empty signal

This function is used to provide a warning when the tank is almost empty and to switch off the pump when the tank is empty. To use the pre-empty signal, ensure that the suction line is equipped with two float switches.

Pre-empty signal

The pre-empty signal can be an error signal or a pre-empty signal at socket 3. For a pre-empty signal, relay 1 must be set to "Pre-empty signal". See sections 6. *Electrical connections* and 9.7.1 *Modifying the switch assignment*.

- When the contact of the corresponding float switch closes,
- the error signal relay or pre-empty signal relay switches on, but the pump is not switched off.
 - The LED flashes red.
 - The empty-signal symbol flashes in the display.

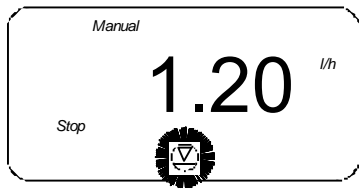

Fig. 18 Display: pre-empty signal

- Once the error has been corrected,
- the error signal relay or pre-empty relay switches off.
 - The pump returns to the state it was in before the error occurred.

Empty signal

- When the contact of the corresponding float switch closes,
- the pump is switched off.
 - The error signal relay switches on.
 - The LED flashes red.
 - The empty-signal symbol lights up in the display.

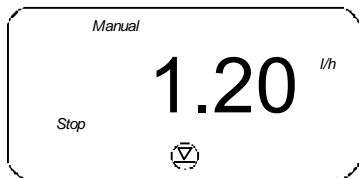

Fig. 19 Display: empty-signal symbol

- Once the error has been corrected,
- the pump starts running again (if it was running before).
 - The error signal relay switches off.
 - The pump returns to the state it was in before the error occurred.

9.2.4 Diaphragm leakage sensor (MLS)

As an option, the pump can be equipped with a sensor for diaphragm leakage detection.

The electronics automatically detects whether a sensor is connected. The following appears in the display.

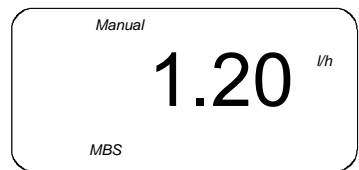

Fig. 20 Display: MLS sensor is connected

- When a diaphragm leakage is detected by the sensor,
- the pump is switched off.
 - The error signal relay switches on.
 - The LED flashes red.
 - "MBS" (MLS) and "ERROR" flash in the display.

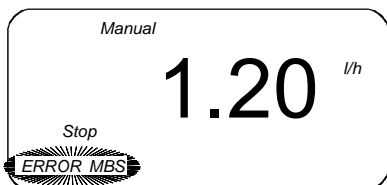

Fig. 21 Display: diaphragm leakage detected

Once the error has been corrected (the contact is no longer closed),

- press the "Start/Stop" button to acknowledge the error.
- The pump starts running again (if it was running before).
- The error signal relay switches off.
- The pump returns to the state it was in before the error occurred.

Note

A cable break of the pressure switch is also indicated as a diaphragm leakage signal (MLS error). After acknowledging the MLS error, the pump continues to operate without error indication!

9.2.5 Blocking safety

If the pump has existing strokes to process, a check is carried out to determine whether the drive is turning. If the drive motor is blocked, e.g. due to excess counter-pressure in the dosing system, this is detected and indicated by the integrated motor monitoring function.

- The error signal relay switches on.
- "1/min", "bar" and "ERROR" flash in the display.

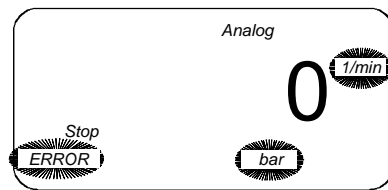

Fig. 22 Display: motor monitoring

- The pump is stopped.
- The red LED flashes.

For possible errors and their correction, see section 11. *Fault finding chart.*

Once the error has been corrected,

- press the "Start/Stop" button to acknowledge the error.

9.2.6 Power off

If the power consumption of the drive motor is too high, e.g. due to excess counter-pressure in the dosing system, this is detected and indicated by the power monitoring function.

- The error signal relay switches on.
- "1/min", "bar" and "ERROR" flash in the display.
- The pump is stopped. Every 10 minutes, an attempt is made to automatically restart the pump.
- The LED flashes red/green.

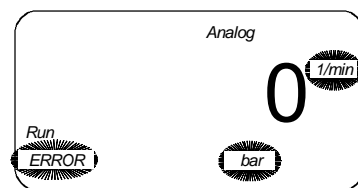

Fig. 23 Display: power off

For possible errors and their correction, see section 11. *Fault finding chart.*

Once the error has been corrected,

- the pump restarts automatically, or
- press the "Start/Stop" button to acknowledge the error.

TM03 6596 4506

TM03 6597 4506

TM03 6598 4506

TM03 6599 4506

TM03 6763 4506

TM03 6360 4506

9.2.7 Remote on/off

The pump can be switched off remotely (e.g. from a control room).

- If switched off remotely, the pump does not respond to any input signals or to operator input.
Exception: The pump can still be stopped manually (press the "Start/Stop" button) and run in continuous operation (press and hold down the "Start/Stop" button).
- "Stop" lights up in the display.
- The yellow LED lights up.
- When switched on remotely, the pump returns to the state it was in before it was switched off. If, for example, the pump was previously in "Stop" mode, it returns to this mode once it is switched on.

9.2.8 Memory function

Contact signals, which cannot be processed immediately, can be stored and subsequently made available to the pump for processing. A maximum of 65,000 contact signals can be stored.

- **Without memory:** If the pump is running when a contact signal is received, the signal is ignored. The pump performs the current dosing, then it is again ready to receive new contact signals, i.e. it rejects excess contacts.
- **With memory:** If the pump is running when a contact signal is received, the signal is stored in the memory. First, the pump performs the current dosing, then it processes the contact signals from the memory.

The contents of the memory are deleted:

- by switching off the power supply
- by switching the operating mode.

The contents of the memory are not deleted:

- by actuating the remote on/off contact
- by pressing the "Start/Stop" button
- by continuous operation.

Note *The memory function can be enabled and disabled in the second function level.*

9.2.9 Flow Monitor

The pump can be equipped with a pressure sensor (Flow Monitor pump option).

Based on the pressure measured by the sensor and on the motor position, an indicator diagram is created. Possible dosing faults or the exceeding of the permissible counter-pressure are detected reliably and indicated by the display or the error message output.

The following errors are recognised:

- Pressure exceeded (the pump is stopped and restarts automatically when the pressure decreases).
- Dosing error (the pump doses 30 % to 100 % less due to a leaking discharge valve or suction valve, a clogged suction line or an air bubble in the dosing head).

Caution *Depending on the operating conditions, it may be impossible to detect dosing errors due to several faults occurring simultaneously (e.g. leaking suction and discharge valves)!*

The dosing controller and dosing control functions can be switched on and off independently of each other. It is always possible to display the pressure that has been measured during operation whenever the pressure sensor is connected.

Note *For information about operating the pump with the Flow Monitor, see section 9.10 Flow Monitor.*

9.3 Signal outputs

The control unit has the following signal outputs, e.g. in order to return a signal to the control room.

9.3.1 Current signal output

Note *To use the control signal output, see section 9.9 Current signal control 0-20 mA / 4-20 mA.*

The current flow rate of the pump is output as a current signal.

- Current output 0-20 mA in the following mode:
 - Current control 0-20 mA.
- Current output 4-20 mA in the following modes:
 - Current control 4-20 mA
 - Manual
 - Contact
 - Batch dosing with manual/contact start
 - Timer with manual/contact start.

Note *The current output is linear between 4 (0) mA at flow rate = 0 and 20 mA at maximum flow rate Q_{max} . (default setting) or the corresponding weighting value pair.*

9.3.2 Error signal

Used to return various error states to the control room.

9.3.3 Stroke signal / pre-empty signal / pulse input

Depending on the relay setting, the contact output receives a signal in these cases:

- for each complete stroke of the pump, or
- a pre-empty signal input, or
- each pulse input at the pump.

To set the relay, see section 9.7.1 *Modifying the switch assignment.*

9.4.1 Setting the operating modes

The operating modes are selected in the first function level, and settings can be made for the modes.

This function level can only be opened when the pump is stopped.

- When the pump is stopped (LED lights up red), press the "Menu/Info" button.
 - The first function level is opened.
- Navigate in the first function level by repeatedly pressing the "Menu/Info" button.
- Use the "Up" and "Down" buttons to modify the settings in the relevant menu as shown in fig. 24.
- Press the "Start/Stop" button to confirm the settings and to exit the first function level.
 - The pump is running (LED lights up green).

9.4.2 Manual control

Dosing with manual on/off and manually adjustable dosing flow

In this operating mode, all the settings are entered on the pump by the operator.

- Use the "Start/Stop" button to start or stop the pump.
- Use the "Up" and "Down" buttons to increase or decrease the flow rate. This can be done when the pump is stopped or when it is running.

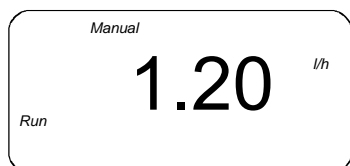

Fig. 25 Display: manual control

The maximum displayed/adjustable flow rate is automatically set according to the selected pump type and the calibrated stroke volume.

Input range for the flow rate

Pump type	$Q_{min.}$ [l/h]	Resolution of flow rate
DDI 60-10	0.075	20 ml/h for $Q < 10$ l/h 100 ml/h for $Q \geq 10$ l/h
DDI 150-4	0.188	20 ml/h for $Q < 10$ l/h 100 ml/h for $Q \geq 10$ l/h 1 l/h for $Q \geq 100$ l/h

9.4.3 Contact signal control

Note

The pump must be started first in this operating mode (LED lights up green and "Run" appears in the display).

- Use the "Start/Stop" button to start or stop the pump.

For continuous dosing in a process

For each signal received at the contact input of the pump (e.g. from a water meter with reed contact output), the pump doses the set dosing capacity. The dosing is continuously distributed between the incoming contacts via a controller. The maximum dosing capacity must not be exceeded.

Input range for the dosing capacity per contact

Pump type	Min. dosing capacity (= 1/50 stroke/contact)	Max. dosing capacity (= 4 strokes/contact)
	[ml]	[ml]
DDI 60-10	0.111	22.2
DDI 150-4	0.278	55.5

Even if the pump receives more contact signals than it can process at the maximum flow rate, it only runs in continuous operation with a maximum stroke frequency of 180/min. (120/min. in slow mode).

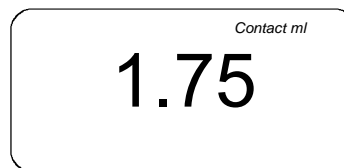

Fig. 26 Display: contact signal control

Use the "Up" and "Down" buttons in the first function level to set the dosing volume for each contact signal.

- When the pump is stopped (LED lights up red), press the "Menu/Info" button.
 - The first function level is opened.
- Use the "Up" and "Down" buttons in the "contact signal control" menu to set the dosing volume per contact signal.
- Press the "Start/Stop" button to confirm the settings and to exit the first function level.
 - The pump is running (LED lights up green).

Note

Due to the constant dosing control, the pump can continue dosing for a short time even when no contact has been received.

9.4.4 Current signal control 0-20 mA / 4-20 mA

For current signal control, see section 9.9 Current signal control 0-20 mA / 4-20 mA.

9.5 Second function level

9.5.1 Opening / exiting the second function level

Open the second function level

- to set the access code,
- to enable or disable functions such as Flow Monitor or memory,
- to enter settings for operating modes such as batch mode,
- to display the total number of operating hours and total dosing capacity,
- to carry out a calibration, or
- to modify the assignment between the current input/output and dosing rate.

This function level can only be opened when the pump is stopped (LED lights up red).

9.5.2 Setting the access code

The access code is used to protect the pump against unintentional/unauthorised access to pump settings.

The default setting is 111. Code 111 gives access to all settings described in sections 9.4 *First function level* and 9.5 *Second function level*.

Note *The "Start/Stop" button for stopping the pump is active with any code.*

1. Press the "Start/Stop" button while the pump is running (LED lights up green).
 - The pump is stopped (LED lights up red).
2. Press and hold down the "Menu/Info" button for 3 seconds.
 - The second function level is opened.
 - The input arrow appears in the display.
 - "C:111" (default setting is "111") or a user-defined code appears in the display.
3. Use the "Up" and "Down" buttons to set the code in the range between 1 and 999.

Code 111 is required to open the second function level.

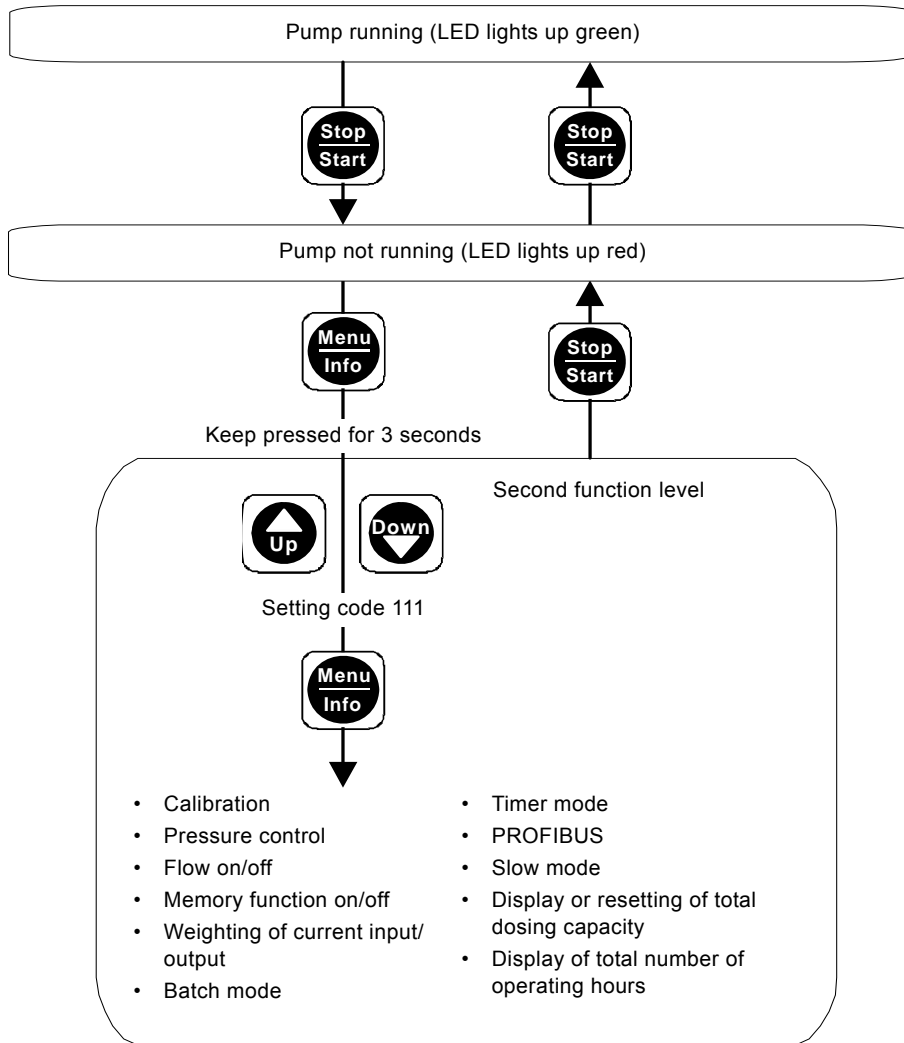

Fig. 27 Opening / exiting the second function level

1. Navigate in the second function level by repeatedly pressing the "Menu/Info" button.
2. Use the "Up" and "Down" buttons to modify the settings in the relevant menu as shown in figs 28 and 29.
3. Press the "Start/Stop" button to exit the second function level.

Note *You can only change the parameters in the shown order. When the "Menu/Info" button is pressed again (after one run), the first function level opens automatically.*

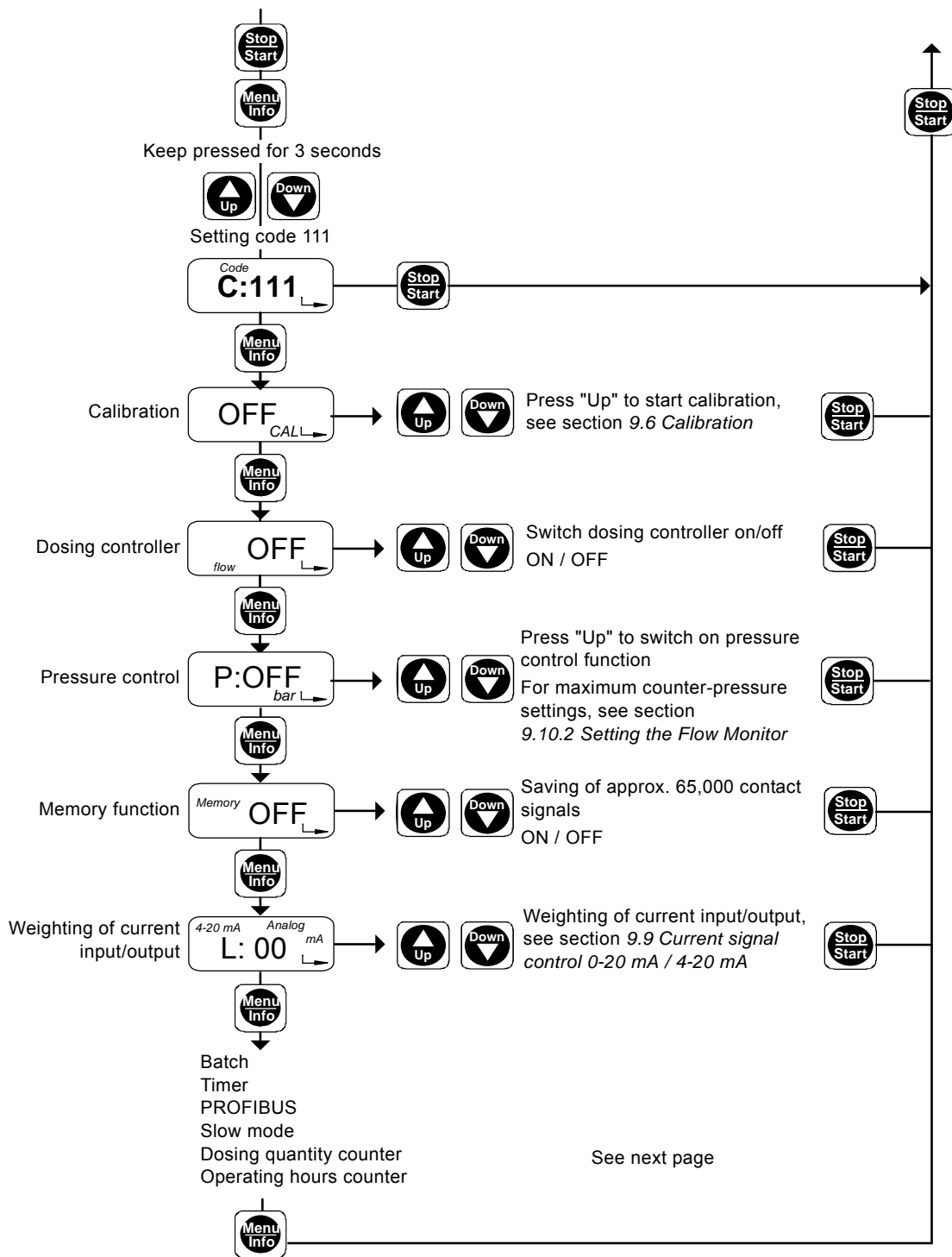

Fig. 28 Second function level, part 1

TM03 6609 4506

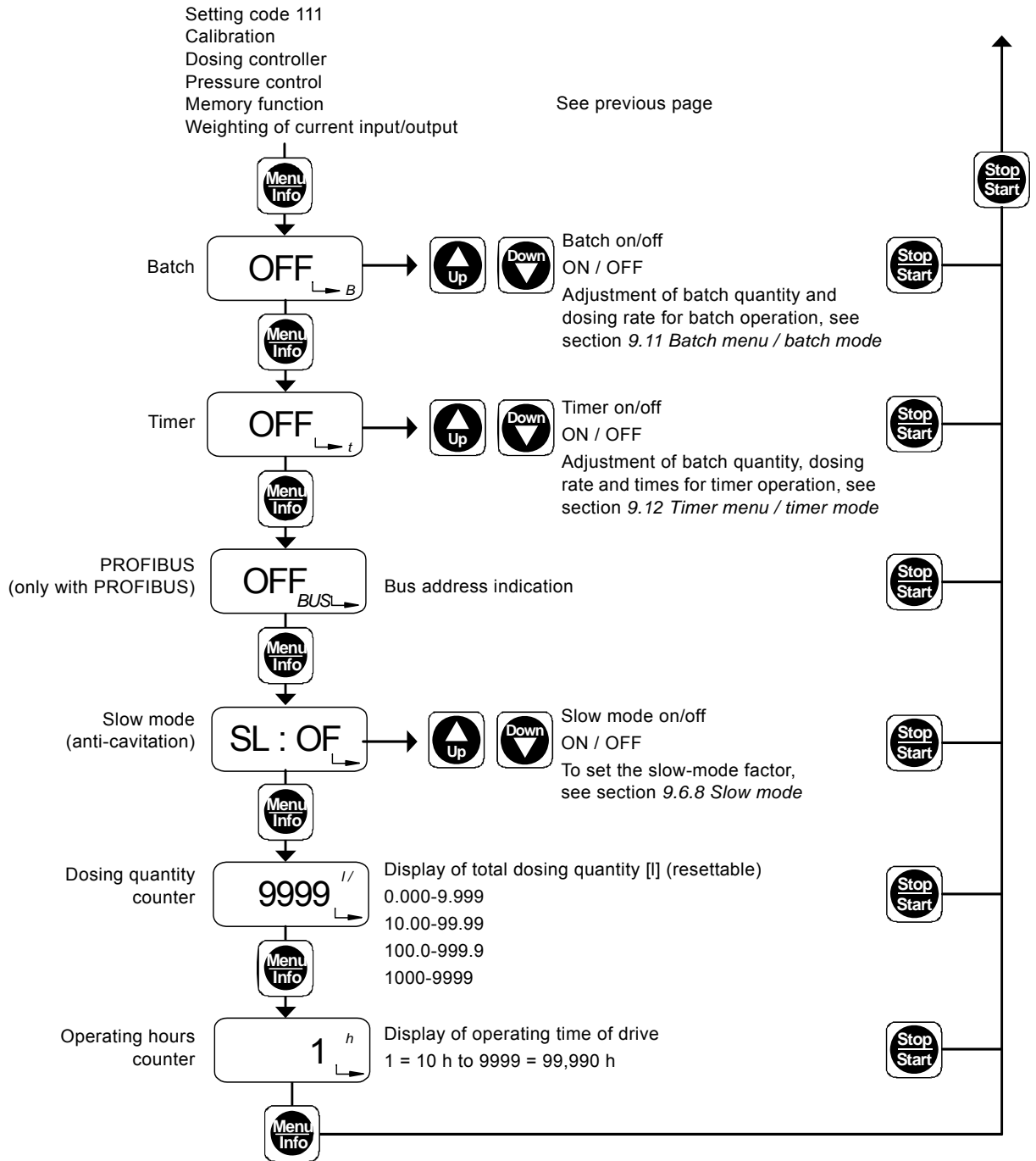

Fig. 29 Second function level, part 2

9.6 Calibration

The dosing flow display is set by default for an operating counter-pressure of 3 bar. Calibration can be used to set the pump flow to the actual operating conditions.

With activated flow compensation (see section 4.4.4 Flow compensation):

Note When dosing media with a viscosity different from water or after a software update the pump has to be calibrated. After a software update "cal" is flashing in the display.

Calibrate the pump under normal operating conditions with the discharge line connected and at operating counter-pressure.

Note The dosed volume must be gauged in litres during calibration, e.g. by drawing the dosing medium from a gauged tank.

"OFF CAL" appears in the display.

- Press the "Up" button.
 - "- - -" and "CAL" (flashing) appear in the display.
- Wait until "ON" and "CAL" (not flashing) appear in the display.
 - "ON CAL" appears in the display.

- Press the "Start/Stop" button.
 - Calibration is started. The LED flashes green and "Run" flashes in the display.
- 200 strokes are performed by default. The number of strokes performed appears in the display.
- Press "Start/Stop" to stop at any stroke value.
 - The LED lights up red.
- Press the "Start/Stop" button.
 - The current calibration value is displayed (not with replacement circuit boards!).
- Use the "Up" and "Down" buttons to enter the calibration value (gauged volume in ml).
 - Press the "Menu/Info" button (confirm the setting and move on to the next menu item), or
 - press the "Start/Stop" button (confirm the setting and close the second function level).

The calibration process does not change the setting for the assignment/weighting of the current input and output for the flow rate.

Note If a current input or output is used, check after calibration to determine whether a new current weighting is required.

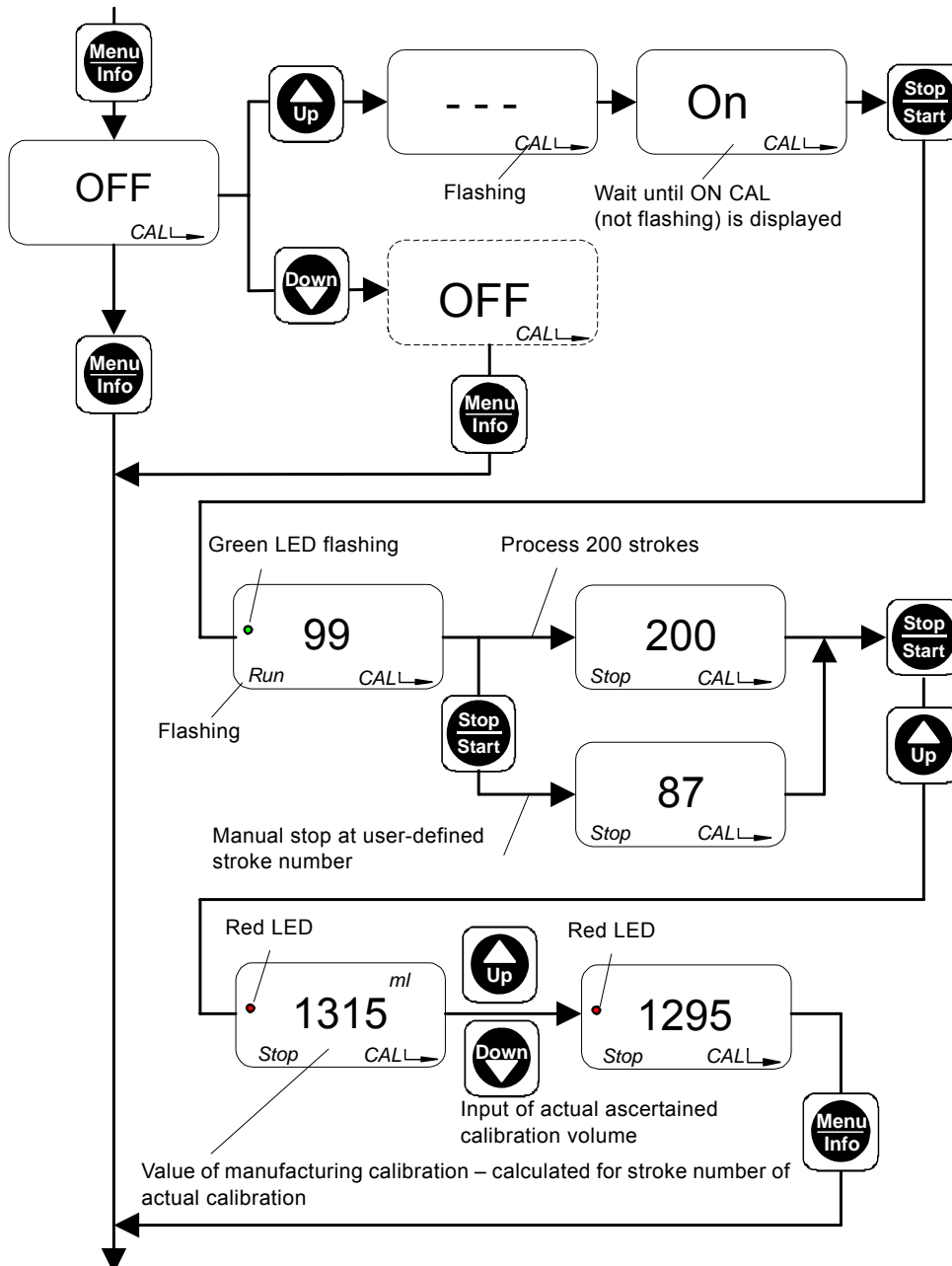

Fig. 30 Calibration

Adjusting the operating counter-pressure without gauging the dosed volume during calibration

If you do not gauge the dosed volume, you can determine the "calibration value" from the following dosing capacity curves in order to adjust your pump to the operating counter-pressure.

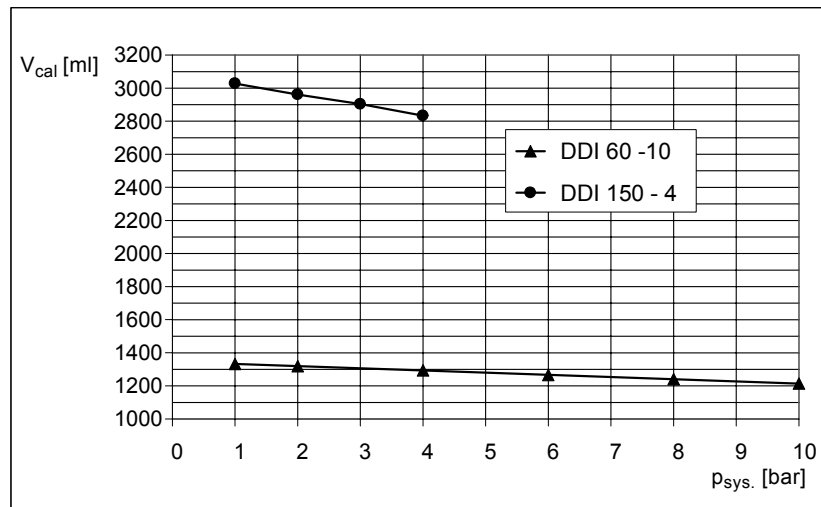

Fig. 31 Dosing capacity curves

Note

Values are approximate values and do not take into consideration deviations due to construction tolerance according to VDMA 24284.

9.6.1 Flow Monitor

In order for the pressure sensor (if installed) to function as a dosing controller, the dosing controller must be switched on. See section 9.10 Flow Monitor.

9.6.2 Pressure control

In the pressure control menu, the pressure control function is switched on or off and the stop counter-pressure is set. See section 9.10 Flow Monitor.

9.6.3 Memory function

The memory function is used to store excess contact signals for processing later. See section 9.6.3 Memory function.

- Switch the memory function on/off with "Up" / "Down".
- Press the "Menu/Info" button (confirm the setting and move on to the next menu item), or
- press the "Start/Stop" button (confirm the setting and close the second function level).

9.6.4 Weighting of current input/output

In current input/output operation, the dosing capacity is controlled via the current signal. The pump emits a current signal as a feedback for control rooms or master/slave applications.

Note

For weighting of current input/output, see also 9.9 Current signal control 0-20 mA / 4-20 mA.

9.6.5 Batch menu / batch mode

In batch mode, a defined batch quantity is dosed with a defined dosing flow. The batch can be dosed manually or by a contact. See section 9.11 Batch menu / batch mode.

9.6.6 Timer menu / timer mode

In timer mode, a defined batch quantity is dosed with a defined dosing flow and a defined start time. See section 9.12 Timer menu / timer mode.

9.6.7 PROFIBUS menu

The "PROFIBUS" menu item is only displayed for pumps with PROFIBUS interfaces. The PROFIBUS interface is activated/deactivated in this menu and the bus address is specified.

The curves represent 200 strokes:

- Dosing medium with a viscosity similar to water
- 0.5 m flooded suction.

9.6.8 Slow mode

Slow mode reduces the maximum dosing flow of the pump in two stages to 66 % (slow mode 1) or 41 % (slow mode 2). By increasing the minimum suction time, cavitation is, for example, reduced with viscous media.

Slow mode can be activated in any operating mode. In the slow-mode menu, the slow mode function is set and the slow-mode factor is selected.

Setting slow mode

In the second function level, "SL:OF" appears in the display.

- Use the "Up" and "Down" buttons to switch between normal operation (SL:OF), slow mode 1 (SL:01) and slow mode 2 (SL:02).
 - The current slow-mode factor appears in the display.
- Press the "Menu/Info" button (confirm the setting and move on to the next menu item), or
- press the "Start/Stop" button (confirm the setting and close the second function level).

The maximum flow rate of the pump decreases.

The maximum stroke rate is 120 1/min. in slow mode 1 and 74 1/min. in slow mode 2. The minimum adjustable flow rate is maintained.

Note

9.6.9 Display/resetting of total dosing capacity

The total capacity dosed since the value was last reset is displayed.

Note

The maximum value that can be displayed is 9999 l. If this value is exceeded, the counting starts again at zero.

To reset the value,

1. press the "Up" button.
 - "dEL" appears in the display.
2. Press the "Start/Stop" button.
 - The total dosing capacity is deleted.
- Press the "Menu/Info" button (confirm the setting and move on to the next menu item), or
- press the "Start/Stop" button (confirm the setting and close the second function level).

Display of value during pump operation (in "Run" mode)

- Press the "Menu/Info" button.
 - The total capacity dosed since the value was last reset is displayed.

9.6.10 Display of total number of operating hours

The operating hours counter indicates the operating time of the drive, e.g. to check maintenance intervals. The maximum number of operating hours that can be displayed is 99,990 h (display = 9999).

The operating hours counter cannot be reset.

Note *Multiply the number displayed by 10 to determine the number of operating hours.*

9.7 Service level

Open the service level

- to modify the switch assignments of the electronics,
- to set the pump type, or
- to select the unit of measurement for the dosing flow (l/h or gal/h) that will be displayed.

9.7.1 Modifying the switch assignment

Note *You are modifying the default settings of your control unit. They will therefore differ from the technical data.*

The service level can only be accessed when the power supply is switched on.

1. Simultaneously press the "Menu/Info" and "Down" buttons and hold them down.
2. Switch on the power supply.
 - The LED alternately flashes red and green.
3. Release the "Menu/Info" and "Down" buttons.
4. Press the "Start/Stop" button.
5. Press the "Up" button.
 - The LED lights up yellow.
 - "Func" appears in the display.
6. Press the "Menu/Info" button.
 - The service level is opened.

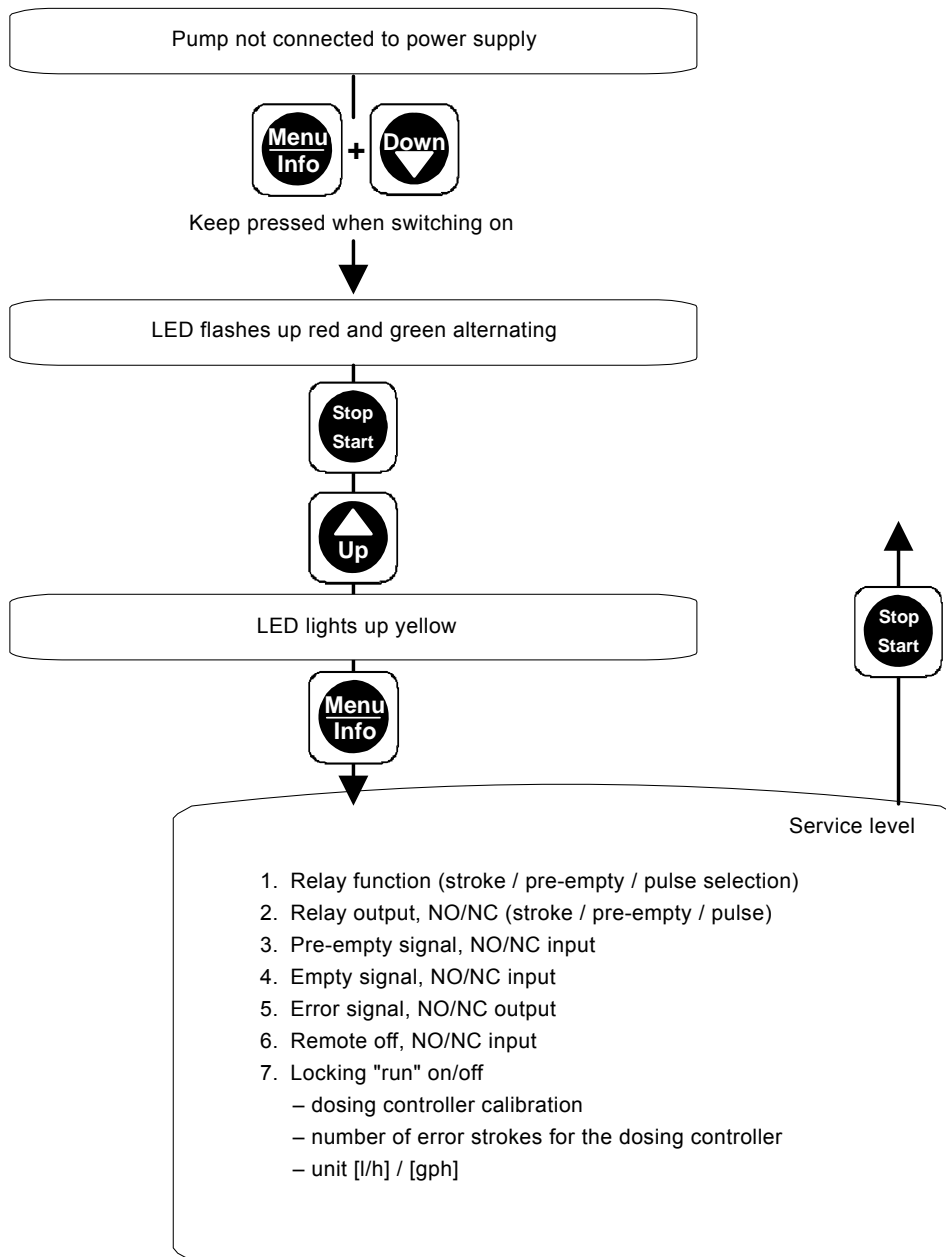

Fig. 32 Opening / exiting the service level

1. Navigate in the service level by repeatedly pressing the "Menu/Info" button.
2. Use the "Up" and "Down" buttons to modify the switch assignment in the relevant menu.
3. Press the "Menu/Info" button for 10 seconds to open the pump type selection.
4. Press the "Start/Stop" button
 - to confirm the new settings
 - to exit the service level
 - to open the first function level.

1. Relay function (stroke / pre-empty / pulse selection)

"1:OFF", "1:ON" or "1:1:1" appears in the display.

- Use the "Up" and "Down" buttons to switch between:
 - "1:OFF": Relay function = stroke signal ("1/min" flashes in display), and
 - "1:ON": Relay function = pre-empty signal (empty-signal symbol flashes in the display), and
 - "1:1:1": Relay function = pulse input ("n:1" flashes in the display).
- Press the "Menu/Info" button (confirm the setting and move on to the next menu item), or
- press the "Start/Stop" button (confirm the setting and close the service level).

2. Relay output, NO/NC (stroke / pre-empty / pulse)

"2:NO" or "2:NC" appears in the display ("1/min" and empty-signal symbol flash in the display).

- Use the "Up" and "Down" buttons to switch between:
 - "2:NO": Stroke/pre-empty signal/pulse input relay = normally open contact, and
 - "2:NC": Stroke/pre-empty signal/pulse input relay = normally closed contact.
- Press the "Menu/Info" button (confirm the setting and move on to the next menu item), or
- press the "Start/Stop" button (confirm the setting and close the service level).

3. Pre-empty signal, NO/NC input

"3:NO" or "3:NC" appears in the display (empty-signal symbol flashes in display).

- Use the "Up" and "Down" buttons to switch between:
 - "3:NO": Pre-empty signal = normally open contact, and
 - "3:NC": Pre-empty signal = normally closed contact.
- Press the "Menu/Info" button (confirm the setting and move on to the next menu item), or
- press the "Start/Stop" button (confirm the setting and close the service level).

4. Empty signal, NO/NC input

"4:NO" or "4:NC" appears in the display (empty-signal symbol lights up in the display).

- Use the "Up" and "Down" buttons to switch between:
 - "4:NO": Empty signal = normally open contact, and
 - "4:NC": Empty signal = normally closed contact.
- Press the "Menu/Info" button (confirm the setting and move on to the next menu item), or
- press the "Start/Stop" button (confirm the setting and close the service level).

5. Error signal, NO/NC output

"5:NO" or "5:NC" appears in the display ("ERROR" flashes in the display).

- Use the "Up" and "Down" buttons to switch between:
 - "5:NO": Error signal relay = normally open contact, and
 - "5:NC": Error signal relay = normally closed contact.
- Press the "Menu/Info" button (confirm the setting and move on to the next menu item), or
- press the "Start/Stop" button (confirm the setting and close the service level).

6. Remote off, NO/NC input

"6:NO" or "6:NC" appears in the display ("Run" and "Stop" flash in the display).

- Use the "Up" and "Down" buttons to switch between:
 - "6:NO": Remote off = normally open contact, and
 - "6:NC": Remote off = normally closed contact.
- Press the "Menu/Info" button (confirm the setting and move on to the next menu item), or
- press the "Start/Stop" button (confirm the setting and close the service level).

7. Locking "run" on/off

The locking of the "Start/Stop" button to prevent manual stopping of the pump can be enabled and disabled.

The display indicates "7:ON" or "7:OFF" (the "Run" symbol is displayed).

- Use the "Up" and "Down" buttons to switch between:
 - "7:ON": Locking "run" on, and
 - "7:OFF": Locking "run" off.
- Press the "Menu/Info" button (confirm the setting and move on to the next menu item), or
- press the "Start/Stop" button (confirm the setting and close the service level).

P: CAL on/off (only for Flow Monitor)

"CAL:ON" or "CAL:OFF" appears in the display ("CAL" appears).

- Use the "Up" and "Down" buttons to switch between:
 - "CAL:ON": Calibration of the pressure sensor for the Flow Monitor enabled, and
 - "CAL:OFF": Calibration of the pressure sensor for the Flow Monitor disabled.

Note

For calibration, see section 9.10.7 Calibrating the sensor after the sensor has been replaced.

St: e.g. "60" (only for Flow Monitor)

- Use the "Up" and "Down" buttons to set the "number of error strokes permitted when starting". If the number of error strokes is exceeded, the "Flow error" error message appears.

FE: e.g. "7" (only for Flow Monitor)

- Use the "Up" and "Down" buttons to set the "number of error strokes permitted during operation". If the number of error strokes is exceeded, the "Flow error" error message appears.

Selection of unit (display)

"Unit l/h" or "Unit gph" appears in the display.

- Use the "Up" and "Down" buttons to switch between:
 - "Unit l/h": Unit Q = l/h, and
 - "Unit gph": Unit Q = gal/h.
- Press the "Start/Stop" button (confirm the setting and close the service level), or
- press the "Menu/Info" button for a minimum of 10 seconds (confirm the setting and open the pump selection).

Pump selection

The actual pump type must always be selected to ensure error-free operation of the electronic control function. Otherwise the displayed pump and signals differ from the actual conditions.

Caution

"-60" or "-150" appears in the display.

- Use the "Up" and "Down" buttons to switch between the pump types DDI 60-10 and DDI 150-4.
- Select your pump type, which is indicated on the pump nameplate.
- Press the "Start/Stop" button (confirm the setting and close the service level).

9.8 Resetting to default settings

You can reset the first and second function levels to the default settings when the power supply is being connected.

Note

The service level settings (pump type, unit of display for the dosing flow, input and output settings) and the values for the total dosing capacity and operating hours counter remain as they are.

The pump is disconnected from the power supply.

1. Simultaneously press the "Up" and "Down" buttons and hold them down.
2. Switch on the power supply.
 - "boot" appears in the display.
3. Release the "Up" and "Down" buttons.
 - All modified settings at the first and second function levels are reset to the default settings.

9.9 Current signal control 0-20 mA / 4-20 mA

For controlling the dosing pump via an external current signal of 0-20 mA (4-20 mA)

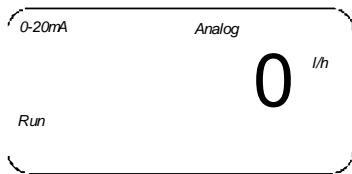

TM03 6603 4506

Fig. 33 Display: 0-20 mA current signal control

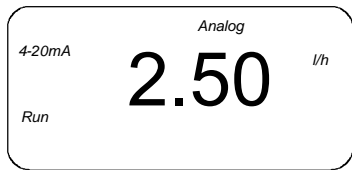

TM03 6604 4506

Fig. 34 Display: 4-20 mA current signal control

- The flow rate is proportional to a current input signal of 0-20 mA (4-20 mA).
- Above 19.5 mA, the pump runs in continuous operation at maximum dosing flow (Q_{max}).
- Below 0.2 (4.2) mA, the pump switches off.

Note

Default setting for Q_{max} is the dosing flow up to 3 bar (default calibration value). Once the pump has been calibrated, the current signals must be weighted. See sections 9.9.2 With calibrated pump and 9.9.3 Setting the weighting.

Note

The pump must be started first in this operating mode (LED lights up green and "Run" appears in the display).

- Use the "Start/Stop" button to start or stop the pump.

4-20 mA current signal control

If the current input signal falls below 2 mA, the error relay is switched, as an error has probably occurred at the signal source or on the cable.

- The error signal relay switches on. The LED flashes red.
- "4-20 mA" and "ERROR" flash in the display.

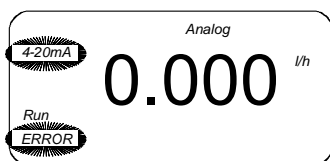

TM03 6605 4506

Fig. 35 Display: 4-20 mA current signal control

The assignment between the current signal and flow rate is linear.

- With 0-20 mA current signal control, the curve for current input and current output passes through $Q = 0$ at 0 mA and the value pair $Q_{max.} (Q_{cal})$ at 20 mA (curve 1a).
- With 4-20 mA current signal control, the curve for current input and current output passes through $Q = 0$ at 4 mA and the value pair $Q_{max.} (Q_{cal})$ at 20 mA (curve 2a).
- With manual or contact control, the curve for current output passes through $Q = 0$ at 4 mA and the value pair $Q_{max.} (Q_{cal})$ at 20 mA (curve 2a).

The default setting for $Q_{max.}$ is the maximum dosing flow at default calibration at 3 bar.

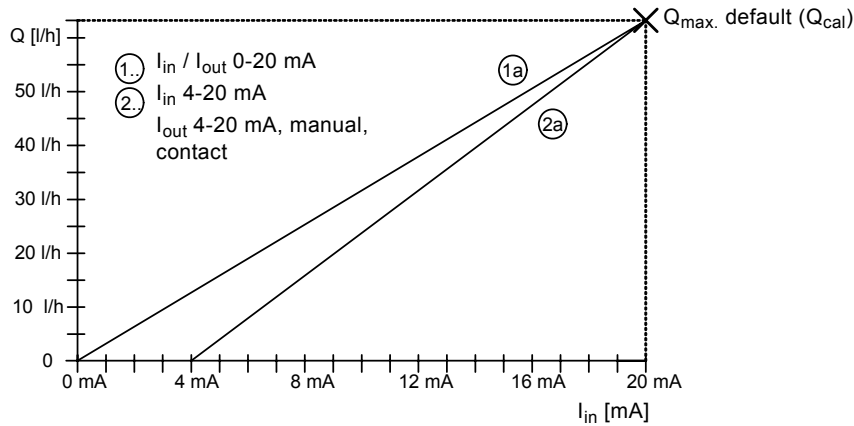

Fig. 36 Current input and current output with default setting

9.9.1 Direct weighting of the current signal input and output

Weighting while the pump is running can be carried out in the first function level. The currently set value increases or decreases for the maximum flow rate $Q_{max.} (Q_{cal})$, or with weighting set value $Q_{select\ mA\ max.}$.

Setting the weighting

The parameters for 0-20 mA and for 4-20 mA are independent of one another. The weighting parameters are modified and saved according to the set operating mode.

Note

Select the current control used (0-20 mA / 4-20 mA) before weighting.

Weighting can be set independently of the current input value that is currently set. The dosing flow value [l/h] that corresponds to the set current input value [mA] always appears in the display.

Note

1. When the pump is running or stopped, press and hold down the "Up" button for approximately 5 seconds.
 - "0-20 mA" or "4-20 mA", "Analog" and "l/h" flash in the display.
2. Use the "Up" and "Down" buttons to increase or decrease the currently set value for the maximum flow rate.

The curve for current input/current output now passes as follows:

- With 0-20 mA (4-20 mA) current signal control, the curve for current input and current output passes linearly through $Q = 0$ at 0 mA (4 mA) and the currently set value for the maximum flow rate $Q_{select\ max.}$ at 20 mA (curves 1b and 2b).

The set weighting is saved in the pump. The values are retained, e.g. when the power supply is switched off, and are also active when current weighting is called in the second function level.

Note

Even for current input/current output assignments that are already weighted in the second function level (see curve 3a), subsequent weighting can be set or weighting can be shifted here. The value for the maximum flow rate $Q_{select\ mA\ max.}$ at $mA_{max.}$ is shifted (curve 3b).

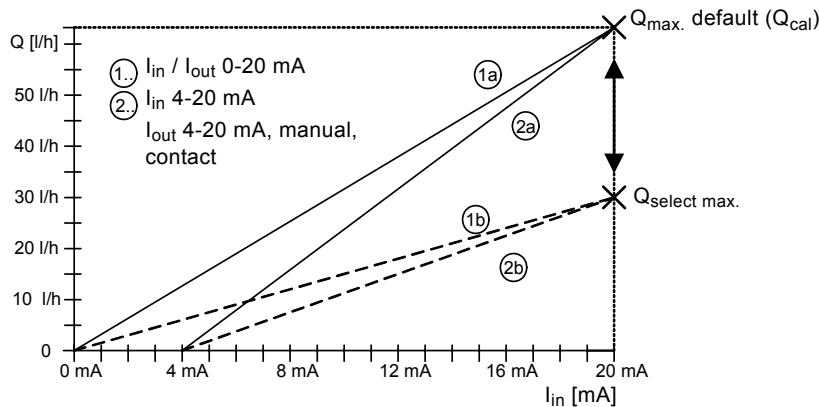

Fig. 37 Current input and current output with direct weighting

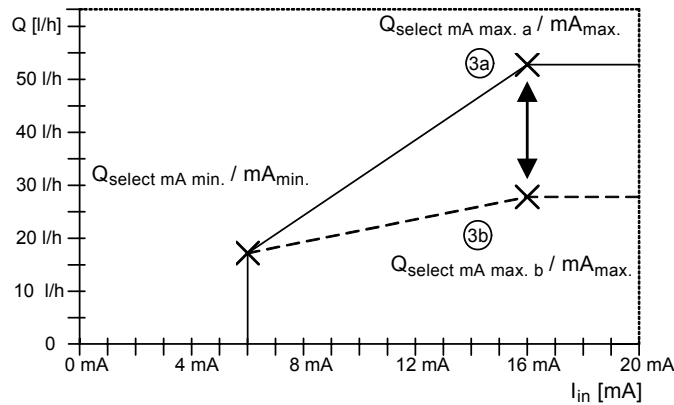

Fig. 38 Current input and current output with subsequent weighting

9.9.2 With calibrated pump

When calibrating the pump for your application and using current signal control and/or current output, proceed as follows:

1. Calibrate the pump.
2. Determine the maximum flow rate Q_{cal} by taking a reading on the pump: Q_{cal} is the maximum adjustable flow rate after calibration, e.g. in manual mode, or the displayed flow rate in continuous operation (press and hold down the "Start/Stop" button for longer than 1 second).
3. To set the current input/current output weighting, see section 9.9.3 *Setting the weighting*.

Note

For unweighted assignment (curves 1a, 2a, see fig. 34) select the following reference points:

L: $mA_{min.} = 0$ (4) mA / $Q_{select\ mA\ min.} = 0$ l/h

H: $mA_{max.} = 20$ mA / $Q_{select\ mA\ max.} = Q_{cal}$

Note

Q_{cal} is not updated automatically when the pump is re-calibrated. This protects the user-defined value pairs. After calibration, new weighting may be required!

9.9.3 Setting the weighting

The setting options for weighting depend on the selected current signal control. The parameters for 0-20 mA and for 4-20 mA are independent of one another. The weighting parameters are modified and saved according to the set operating mode.

Note

Select the current control operating mode used later (0-20 mA / 4-20 mA) manually or via contact signal before weighting. (Weighting of the control output for manual control mode or contact signal control is the same as current weighting 4-20 mA.)

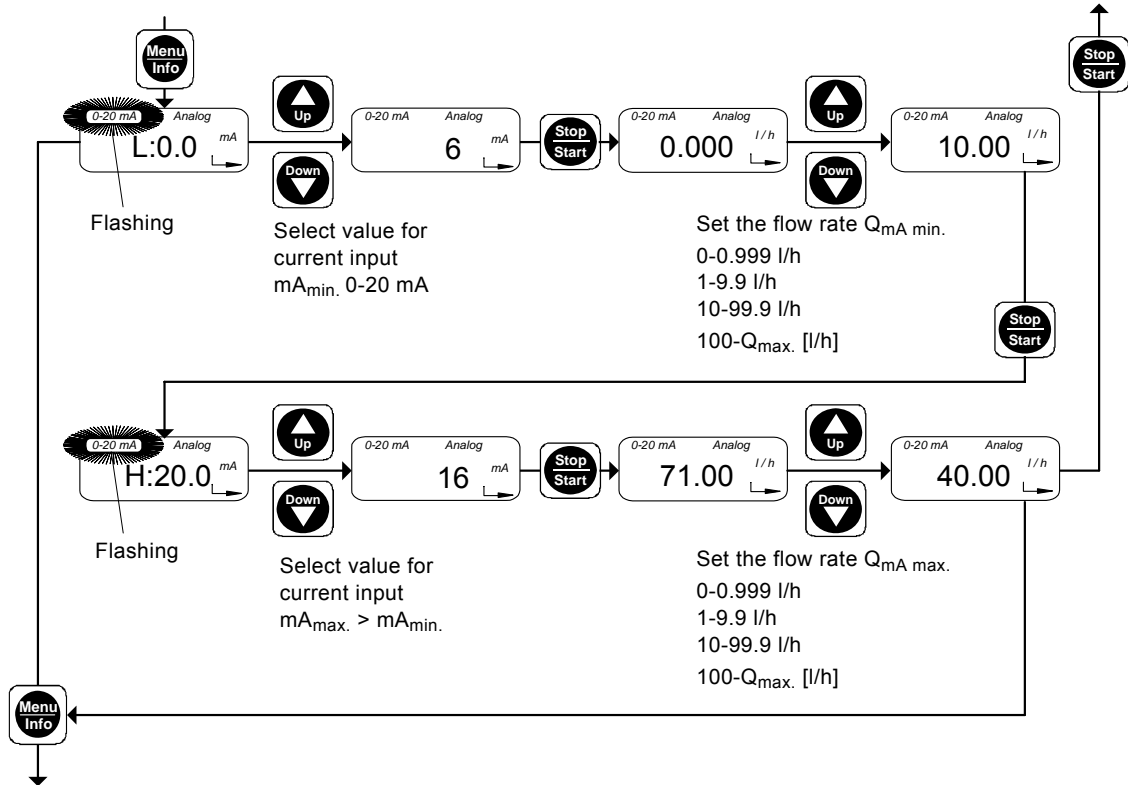

Fig. 39 Setting the weighting

In the second function level, first enter the values for reference pair L:

The display shows

- the current value for $mA_{min.}$.
The default value is "L:0.0 mA" ("L:4.0 mA").
- "Analog"
- "0-20 mA" ("4-20 mA") (flashing).

Proceed as follows:

1. Use the "Up" and "Down" buttons to enter the minimum current input $mA_{min.}$ between 0 mA (4 mA) and 20 mA (e.g. $mA_{min.} = 6$ mA).
2. Press the "Start/Stop" button.
 - The current value for the $mA_{min.}$ assigned flow rate $Q_{mA min.}$ appears in the display (the default value is 0.000).
3. Use the "Up" and "Down" buttons to enter the desired value for flow rate $Q_{mA min.}$ at $mA_{min.}$ (e.g. $Q_{mA min.} = 10$ l/h).

Now enter the values for reference pair H:

1. Press the "Start/Stop" button.
 - The current value for $mA_{max.}$ appears in the display (the default value is "H:20.0 mA").
2. Use the "Up" and "Down" buttons to enter the maximum current input $mA_{max.} > mA_{min.}$ (e.g. $mA_{max.} = 16$ mA).
3. Press the "Start/Stop" button.
 - The current value for the $mA_{max.}$ assigned flow rate $Q_{mA max.}$ appears in the display (the default value is $Q_{max.}$).
4. Use the "Up" and "Down" buttons to enter the desired value for flow rate $Q_{mA max.}$ at $mA_{max.}$ (e.g. $Q_{mA max.} = 40$ l/h).
- Press the "Menu/Info" button (confirm the setting and move on to the next menu item), or
- press the "Start/Stop" button (confirm the setting and close the second function level).

Result of weighting

In the example, the following values were entered as reference points L_d and H_d :

L_d : $mA_{min.} = 6$ mA, $Q_{select mA min.} = 10$ l/h

H_d : $mA_{max.} = 16$ mA, $Q_{select mA max.} = 40$ l/h.

The curve for current input/current output now passes through $Q = 0$ at < 6 mA, from $Q = 10$ l/h at 6 mA to $Q = 40$ l/h at 16 mA, and through $Q = 40$ l/h at > 16 mA (curve 1d).

In the same way, it is also possible to enter a current weighting with a negative gradient. In order to do this, the value pair for reference point L must first be entered with the smaller mA value followed by reference point H.

In the example, the following values were entered as reference points L_e and H_e :

L_e : $mA_{min.} = 2$ mA, $Q_{select mA min.} = 60$ l/h

H_e : $mA_{max.} = 16$ mA, $Q_{select mA max.} = 10$ l/h.

The curve for current input/current output now passes through $Q = 0$ at < 2 mA, from $Q = 60$ l/h at 2 mA to $Q = 10$ l/h at 16 mA, and through $Q = 10$ l/h at > 16 mA (curve 1e).

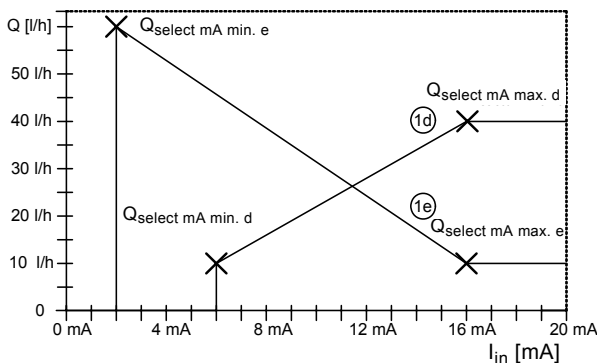

Fig. 40 Result of weighting

Note

The maximum flow rate of the pump must not be exceeded!

Note down the set current weighting in the following diagram for current input/current output:

1. Label the Q [l/h] axis for your working area.
2. Mark your reference points with the value pairs:
L: $mA_{min.} / Q_{select mA min.}$ and
H: $mA_{max.} / Q_{select mA max.}$ in the diagram.
3. Draw the curve as a line from L to H, vertically from $Q_{select mA min.}$ to the mA axis, and horizontally from $Q_{select mA max.}$ to the edge of the diagram.

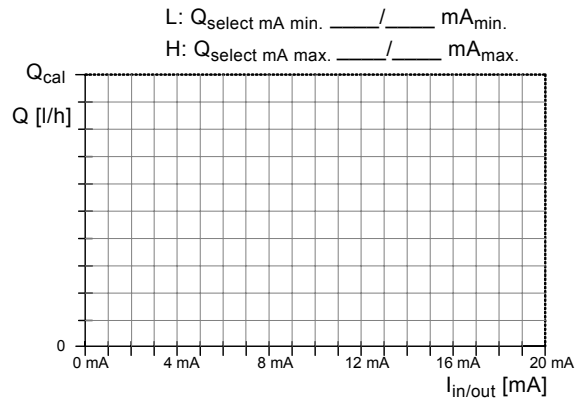

Fig. 41 Diagram for current input/current output

9.10 Flow Monitor

9.10.1 Application notes

Dosing of degassing media (H_2O_2 , chlorine bleaching agents)

- For a robust operation, set the number of permissible error strokes to a value higher than 10.

Dosing of antiscalent (viscosity higher than 20 mPa s)

- Use spring-loaded valves for high-viscosity media.
- When dosing viscous media, see also section 1.3.10 Dosing medium.

Dosing of viscous media

- For media with a viscosity higher than 20 mPa s, spring-loaded suction and discharge valves are recommended.

For batch or timer operation

- Set the number of permissible error strokes to a value lower than the number of working strokes.
- If, while the pump is stopped, the pressure in the discharge line falls below the minimum pressure of 2 bar (e.g. in the event of a leak in the pressure-loading valve), increase the number of permissible error strokes so as to prevent unnecessary error messages.

Ensuring the counter-pressure by a pressure-loading valve:

- Check the counter-pressure 2 to 3 weeks after start-up.
 - If it is below 2 bar, the pressure-loading valve has to be re-adjusted.
 - If the volume flow is not constant (as, for example, in the case of contact or analog control), even small volume flows should not fall below the minimum pressure or minimum pressure difference of 2 bar.

9.10.2 Setting the Flow Monitor

In order for the pressure sensor (if installed) to function as a dosing controller, the dosing controller must be switched on.

To allow the pump to switch off in the event of overpressure and to set the cut-off pressure of the pump, the pressure control function must be switched on and set.

If no pressure sensor is connected, the pump determines the pressure from the motor current.

Note

For applications with high requirements in terms of precision, the pressure control function must be used with a pressure sensor.

Switching on dosing controller

Menu item "flow" is open.

- "flow OFF" appears in the display.
1. Press the "Up" button.
 - "flow ON" appears in the display.
 - The dosing controller is activated.

Switching on pressure control function

Note This menu item only appears if the pressure sensor has already been detected once.

1. Press the "Menu/Info" button.
 - Menu item "P" is open.
 - "P:OFF" appears in the display.
2. Press the "Up" button.
 - "P:ON" appears in the display.
 - The pressure control function is activated.

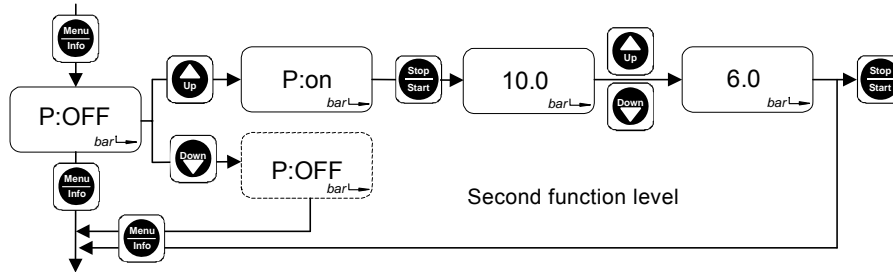

Fig. 42 Set cut-off pressure

"P:ON" in the display:

1. Press the "Start/Stop" button.
 - The currently defined cut-off pressure is shown in the display. The default value is the maximum counter-pressure of the pump type + 1 bar (pumps < 10 bar) or + 2 bar (pumps from 10 bar and up).
2. Use the "Up" and "Down" buttons to enter the desired cut-off pressure.
 - You can set the cut-off pressure at which the pump is to be stopped at around 2 bar up to the default value.
- Press the "Menu/Info" button (confirm the setting and move on to the next menu item), or
- press the "Start/Stop" button (confirm the setting and close the second function level).

Note The actual cut-off pressure $p_{cut-off}$ is higher than the set pressure p_{set} : $p_{cut-off} = p_{set} + 0.5 \text{ bar}$.

When you are setting the cut-off pressure, be aware that the pressure measured in the dosing head is higher than the system pressure. It is advisable to display the measured pressure first, see section Displaying the pressure that has been measured. The set cut-off pressure should be higher than the measured pressure in the dosing head.

Caution

9.10.3 Dosing controller function

The pump software monitors the dosing process and emits a pulse for each dosing stroke. For each stroke, the "flow" display is momentarily turned off.

- When switched on, the electronics detects whether the dosing controller is activated.
 - "flow" appears in the display.

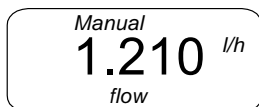

Fig. 43 Display: "Dosing controller"

Suppression of dosing control function during start-up operation

60 error strokes* are permitted during the start-up operation, before an error signal is emitted. After a further 7 error strokes*, a dosing error is signalled.

* Default values, see also section 9.7.1 Modifying the switch assignment.

The start-up operation is triggered as follows:

- By switching on the power supply.
- Deaeration operation (continuously pressing the "Start/Stop" button).

The start-up operation is completed

- after 60 strokes.
- after the first valid stroke signalled by the dosing controller.
- after short switching on and off the pump by pressing the "Start/Stop" button.

The number of permissible error strokes can be increased or decreased since, depending on pump type for example, 60 strokes may take a considerable time during the start-up operation.

Dosing error (after start-up operation)

If, after seven successive strokes or after the number of strokes which have been defined by the user, the dosing controller does not emit a signal. This is recognised as an error:

- The error signal relay switches on, but the pump is not switched off.
- The LED flashes red.
- "flow" and "ERROR" flash in the display.

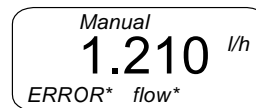

Fig. 44 Display: "Dosing error"

Once the error has been corrected and seven valid strokes have been measured or the "Start/Stop" button has been pressed, the error signal relay switches off.

- The pump returns to the state it was in before the error occurred.

9.10.4 Pressure control function

Caution To protect the pump and system against excessive pressure build-up, install an overflow valve in the discharge line.

The pressure sensor monitors the pressure in the dosing head. If the set pressure is exceeded by 0.5 bar, the pump switches off. When switched on, the electronics detects whether the chamber pressure control function is activated.

- "bar" appears in the display.

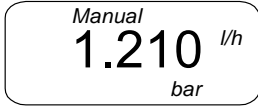

Fig. 45 Display: "Pressure control"

TM03 6577 4506

Pressure exceeded

If, after one stroke, the cut-off pressure is exceeded, this is recognised as an error:

- The pump is stopped.
- The error signal relay switches on.
- The LED alternately flashes red and green.
- The last pressure value to be measured is displayed.
- "RUN", "ERROR" and "bar" flash in the display.

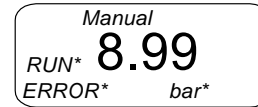

Fig. 46 Display: "Pressure exceeded"

TM03 6578 4506

Pump restart attempts:

- First the pump makes four attempts to restart, each separated by a 2-second pause, if the chamber pressure has fallen below the cut-off pressure ($p_{act} < p_{set}$).
- After the pressure was exceeded, the pump restarts smoothly. If the set cut-off pressure is exceeded, the pump is stopped again immediately.
- After four attempts, the pump waits 10 minutes before attempting to automatically restart again.
- The pump continuously attempts to restart if the chamber pressure decreases in this way.

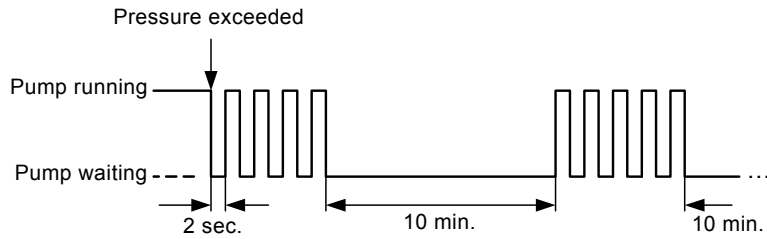

Fig. 47 Pump restart attempts

TM03 6579 4506

Error correction

- Press the "Start/Stop" button to stop the pump and prevent it from restarting.
- Check the discharge valve and the installation on the discharge side and correct any errors, if necessary. For maintenance work, see section 10. Maintenance.
- Check and correct the pressure setting, if necessary.

Once the error has been corrected,

- press the "Start/Stop" button to restart the pump.
 - The pump returns to the state it was in before the error occurred.

Displaying the pressure that has been measured

The pressure that has been measured during the pump operation can be displayed at any time.

- Press the "Menu/Info" button twice. (If only pressed once, the dosed quantity is displayed.)
 - The pressure is displayed for approximately 10 seconds.

9.10.5 Error message – broken cable or faulty sensor

If the dosing controller and/or the pressure control function are/is switched on, the missing signal is recognised and emitted as an error.

A faulty pressure sensor (broken cable) is displayed as follows:

- The error signal relay switches on.
- The pump is not stopped!
- The LED flashes red.
- "ERROR" flashes in the display.

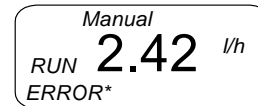

Fig. 48 Display: "Broken cable"

TM03 6580 4506

Correct error

- Press the "Start/Stop" button twice to confirm the error and to stop the pump.
- Repair the cable break.

Once the error has been corrected,

- press the "Start/Stop" button to restart the pump.
 - The pump returns to the state it was in before the error occurred.

If the cable is broken, the dosing controller and pressure control/pressure display functions are not active. When the "Menu/Info" button is pressed twice to display the chamber pressure, only "— — —" is displayed.

Note

If the sensor fault cannot be corrected immediately and if the pump is to continue to run without a sensor, switch off the dosing controller (flow:OFF) and pressure control function (P:OFF).

Note

9.10.6 Changing the number of permissible error strokes

To change the number of permissible error strokes during the start-up operation and during normal dosing operation.

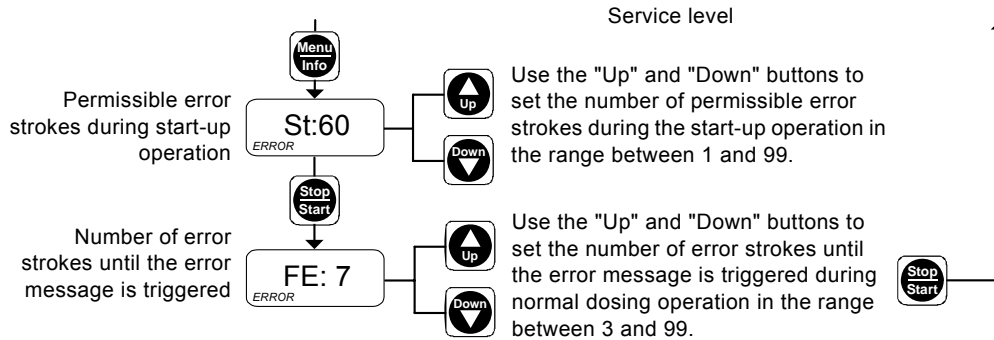

Fig. 49 Permissible error strokes

1. Open the service level.
2. Repeatedly press the "Menu/Info" button to navigate in the service level until you reach menu item "St:60" (error stroke during start-up operation).
 - The display shows "St" and the number of currently defined error strokes that are permissible during the start-up operation.
3. Use the "Up" and "Down" buttons to set the number of permissible error strokes during the start-up operation in the range between 1 and 99.
4. Press the "Start/Stop" button.
 - Confirm the setting and go to menu item "FE: 7".
 - The display shows "FE" and the number of currently defined error strokes that are permissible during normal dosing operation.
5. Use the "Up" and "Down" buttons to set the number of error strokes until the error message is triggered during normal dosing operation in the range between 3 and 99.
6. Press the "Start/Stop" button
 - to confirm the new settings
 - to exit the service level
 - to open the first function level.

9.10.7 Calibrating the sensor after the sensor has been replaced

Once a sensor has been replaced, the new sensor must be calibrated to the ambient pressure.

Prepare the pump for the calibration:

1. Before screwing in the sensor, check that no dosing liquid is left in the place where the pressure sensor will be screwed in!
2. Screw in the new sensor with the correctly fitting O-ring.
3. Screw the sensor plug into socket 2.
4. Unscrew the suction valve.

Calibration of sensor

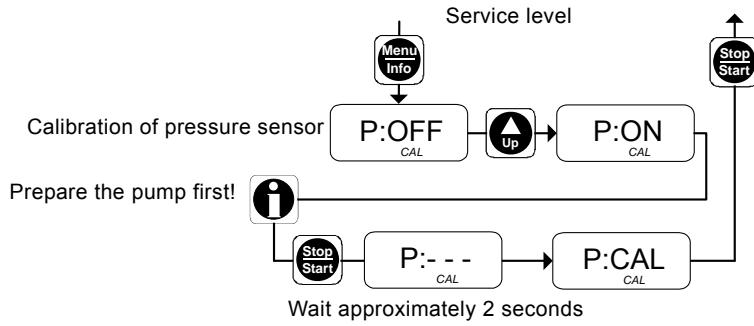

Fig. 50 Calibration of pressure sensor

1. Open the service level.
2. Repeatedly press the "Menu/Info" button to navigate in the service level until you reach menu item "P" (calibration of pressure sensor).
 - "P:OFF" appears in the display.
3. Press the "Up" button to prepare the calibration.
 - "P:ON" appears in the display.

When the pump is prepared for the calibration, calibrate the pressure sensor:

1. Press the "Start/Stop" button.
 - "P:- - -" is displayed for approximately 2 seconds.
 - "P:CAL" appears in the display.
 - The pressure sensor has been calibrated.
2. Press the "Start/Stop" button
 - to confirm the new settings
 - to exit the service level
 - to open the first function level.
3. Fit the pump back on.
4. Screw in the suction valve.

Warning

Risk of chemical burns!



Wear protective clothing (gloves and goggles) when working on the dosing head, connections or lines!

Do not allow any chemicals to leak from the pump. Collect and dispose of all chemicals correctly!

The O-rings must be correctly placed in the specified groove.

Caution

Observe the flow direction (indicated by an arrow)!

Only tighten the valve by hand.

9.11 Batch menu / batch mode

In batch mode, a defined batch quantity is dosed with a defined dosing flow. The batch can be dosed manually or by an external contact signal.

Risk of dosing errors!

Batch dosing using contact inputs may be insufficiently or excessively triggered in the event of an error if the pump/system is not monitored. The system must be protected redundantly.

Caution

Batch mode is controlled at the first and second function levels.

- The batch quantity is set in the second function level.
- The batch function is enabled in the first function level.

Input range for the batch quantity:

0.0-999.9 ml / 1.00-99.99 l / 100.0-999.9 l.

Setting batch dosing

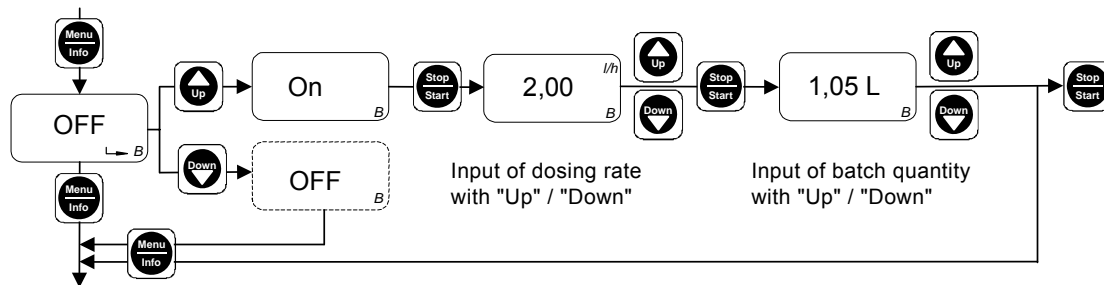

Fig. 51 Setting batch dosing

In the second function level, "OFF B" appears in the display.

1. Press the "Up" button.
 - "ON B" appears in the display.
2. Press the "Start/Stop" button.
 - The currently defined flow rate appears in the display.
3. Use the "Up" and "Down" buttons to enter the desired flow rate.
4. Press the "Start/Stop" button.
 - The currently defined batch quantity appears in the display.
5. Use the "Up" and "Down" buttons to enter the desired batch quantity.
 - Press the "Menu/Info" button (confirm the setting and move on to the next menu item), or
 - press the "Start/Stop" button (confirm the setting, close the second function level and enable batch dosing in the first function level).

Performing batch dosing

- In the first function level, only the batch function is displayed with the "Batch manual" and "Batch contact" menu items.
- "Stop" and the preset batch quantity appear in the display. The LED lights up red.

Use the "Menu/Info" button to select

- "Batch manual", or
- "Batch contact".

Enabling batch mode

Batch manual

Batch dosing is triggered manually.

- Press the "Start/Stop" button.
 - The LED and the "Stop" segment are turned off and "Run" flashes in the display.
 - The preset batch quantity is dosed.

Batch contact

Batch dosing is triggered by an external contact signal.

To activate the batch contact function,

- press the "Start/Stop" button.
 - The LED lights up green, the "Stop" segment is turned off and "Run" appears in the display.

When the external contact signal is received, "Run" flashes in the display.

- The preset batch quantity is dosed.

During batch dosing

The batch quantity still to be dosed appears in the display.

To display the batch quantity already dosed,

- press the "Down" button.

To display the total batch quantity,

- press the "Up" button.

Stop/start of pump during batch dosing

To stop the pump,

- press the "Start/Stop" button, or
- actuate remote on/off.

To re restart the pump,

- press the "Start/Stop" button.
 - The preset batch cycle continues.
 - For the "Contact" timer, an external contact signal must also be received.

Deactivating the batch function

1. Open the second function level.
2. Repeatedly press the "Menu/Info" button.
 - "ON B" appears in the display.
3. Press the "Up" button.
 - "OFF B" appears in the display.
 - The batch function is deactivated.

9.12 Timer menu / timer mode

In timer mode, a defined batch quantity is dosed with a defined dosing flow. The first dosing starts after the start time t_1 has elapsed. Batch dosing is then repeated after the repetition time t_2 has elapsed until the user stops the process by pressing the "Start/Stop" button or with remote off.

- Input range for the batch quantity:
0.0-999.9 ml / 1.00-99.99 l / 100.0-999.9 l
- Input range for the times t_1 and t_2 :
1 min. < t_1 < 999 h / 1 min. < t_2 < 999 h
Input: hh:mm.

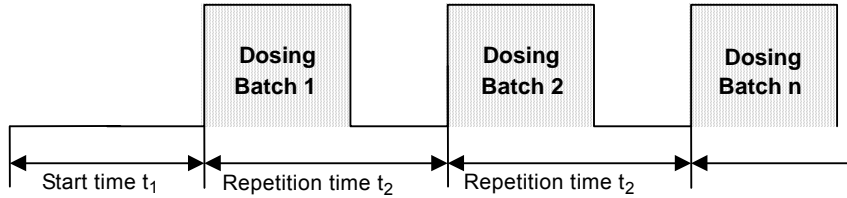

Fig. 52 Timer mode

Risk of dosing errors!

If repetition time t_2 is not long enough to dose the batch quantity at the set dosing flow within this time, the pump continues dosing until the current batch quantity is finished. The pump is then stopped and the next batch dosing is triggered after the next repetition time.

Caution

Batch dosing in timer mode may be insufficiently or excessively triggered in the event of an error if the pump/system is not monitored. The system must be protected redundantly.

Timer mode is controlled at the first and second function levels.

- The batch quantity and times t_1 and t_2 are set in the second function level.
- Timer mode is enabled in the first function level.

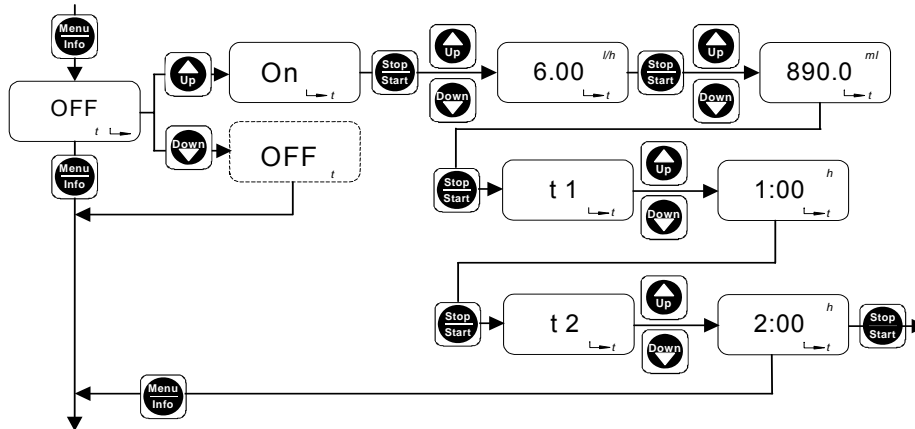

Fig. 53 Setting timer mode

"OFF t" appears in the display.

1. Press the "Up" button.
 - "ON t" appears in the display.
2. Press the "Start/Stop" button.
3. Use the "Up" and "Down" buttons to enter the desired dosing flow.
 - The selected dosing flow appears in the display.
4. Press the "Start/Stop" button.
5. Use the "Up" and "Down" buttons to enter the desired batch quantity.
 - The selected batch quantity appears in the display.
6. Press the "Start/Stop" button.
 - "t1" appears in the display.
7. Use the "Up" and "Down" buttons to enter start time t_1 .
8. Press the "Start/Stop" button.
 - "t2" appears in the display.

9. Use the "Up" and "Down" buttons to enter repetition time t_2 .
 - Press the "Menu/Info" button (confirm the setting and move on to the next menu item), or
 - press the "Start/Stop" button (confirm the setting, close the second function level and enable timer mode in the first function level).

Selecting "Manual" or "Contact" timer mode

- When the pump is running (LED lights up green), press the "Start/Stop" button.
 - "Stop" and the preset start time t_1 appear in the display. The LED lights up red.
 - "Manual" or "Contact" appears in the display ("Manual" is default setting).

In the first function level, only the timer function is displayed with the "Timer manual" and "Timer contact" menu items.

- Use the "Menu/Info" button to select
 - "Timer manual", or
 - "Timer contact".

Enabling timer mode

Timer manual

Batch dosing with the preset pause time is triggered manually.

- Press the "Start/Stop" button.
 - The LED lights up green, the "Stop" segment is turned off and "Run" flashes in the display.
 - The preset batch cycle is started.

Timer contact

Batch dosing with the preset pause time is triggered by an external contact signal.

To activate the batch contact function,

- press the "Start/Stop" button.
 - The LED lights up green, the "Stop" segment is turned off and "Run" appears in the display.

When the external contact signal is received, "Run" flashes in the display.

- The preset batch cycle is started.

During pause times

The time remaining until the next dosing appears in the display.

To display the time already elapsed,

- press the "Down" button.

To display the total time t_1 or t_2 ,

- press the "Up" button.

During timer dosing

The batch quantity still to be dosed appears in the display.

To display the batch quantity already dosed,

- press the "Down" button.

To display the total batch quantity,

- press the "Up" button.

Stop/start of pump during timer dosing

To stop the pump,

- press the "Start/Stop" button, or
- actuate remote on/off.

To restart the pump,

- press the "Start/Stop" button.
 - The preset batch cycle continues.
 - For the "Contact" timer, an external contact signal must also be received.

Deactivating the timer function

1. Open the second function level.
2. Repeatedly press the "Menu/Info" button.
 - "ON t" appears in the display.
3. Press the "Up" button.
 - "OFF t" appears in the display.
 - The timer function is deactivated.

9.13 Creating a master/slave application

You can connect several secondary pumps and control the secondary pumps (slaves) via the first pump (master).

9.13.1 Master

All operating modes are available for the master pump:

- Manual
- Contact
- Batch dosing with manual/contact start
- Timer mode with manual/contact start
- Current control.

Select the output signal of the master pump in the service level (relay 1) (output socket 3):

- Stroke signal (emits one output signal per stroke) must be used for manual or current control of the master pump, or
- pulse input (emits one output signal per contact input signal) must be used for contact control of the master pump.

Alternatively select the current output (output socket 2) for current control of the slave pump.

Please note that the current output can differ from the current input, e.g. when the pump is stopped, and please observe the modified current output values with weighted current control.

Note

9.13.2 Slave

The following operating modes are available for slave pumps in contact or current control (input socket 4):

- Contact
- Batch dosing with contact start
- Timer mode with contact start
- Current control.

Note

The settings for the operating modes of the slave pumps are implemented independently of settings for the master pump.

Unused pulse inputs from the master pump are forwarded to the slave pumps when output signal = pulse input is set. They are processed on the slave pumps according to the slave pump settings!

Caution

9.14 Hotkeys / info keys

The following important displays and functions of the DDI 222 can be accessed quickly using button combinations (hotkeys).

Service functions

Function	Operating state of the pump	Activate function / display	Deactivate function / display
Suction.	In "Run", "Stop" or "Menu/Info" mode.	Press the "Start/Stop" button for at least 1 second.	Release the "Start/Stop" button.
Move back the diaphragm for servicing.	The pump must be in "Stop" mode.	Simultaneously press the "Up" and "Down" buttons.	—
Boot function.	The pump is disconnected from the power supply.	Simultaneously press the "Up" and "Down" buttons while switching on the power supply.	—
Delete the total dosing capacity.	In "Run" mode.	Press the "Menu/Info" button for 5 seconds.	—

Display functions in batch and timer operation

Display / function	Operating state of the pump	Activate function / display	Deactivate function / display
Display the batch quantity already dosed since start of the batch.	During the batch dosing in batch or timer operation.	Press the "Down" button.	Release the "Down" button.
Display total batch quantity.		Press the "Up" button.	Release the "Up" button.
Display the time that has already elapsed.	During pause times in timer operation.	Press the "Down" button.	Release the "Down" button.
Display the total time.		Press the "Up" button.	Release the "Up" button.

Other display functions

Display / function	Operating state of the pump	Activate function / display	Deactivate function / display
Display the total dosing capacity.	In "Run" mode.	Press the "Menu/Info" button.	Display automatically jumps back after 5 seconds.
Display the input current.	In "Analog" mode (0-20 mA / 4-20 mA).	Press the "Down" button.	
Display of pressure in the dosing head.	In "Run" mode.	Press the "Menu/Info" button twice.	Display automatically jumps back after 10 seconds.

9.15 Pump safety functions

The DDI 222 pump is equipped with various safety functions as standard, which are indicated by the following indicators and behaviour of the pump.

Safety functions

Designation	Error	Pump behaviour	LED/display/relay	Behaviour after error removal
Power off.	Excess pressure in the dosing head, or motor power consumption too high.	The pump stops. An attempt to restart automatically is made every 10 minutes.	The LED flashes red/green. "ERROR", "bar" and "1/min" appear in the display. The error signal relay switches on.	Restart after error confirmation and pressing the "Start/Stop" button, or on an automatic restart attempt.
Blocking safety.	Clogged discharge line / blocked motor.	The pump stops after 1 stroke.	The LED flashes red. "ERROR", "bar" and "1/min" appear in the display. The error signal relay switches on.	Restart after error confirmation and pressing the "Start/Stop" button.
Pressure control (can be switched on and off).	When the pressure control function is switched on: Excess pressure in the dosing head (with pressure sensor) or motor power consumption too high.	The pump stops after 3 strokes. An attempt to restart automatically is made every 10 minutes up to 5 times with an increasing number of strokes.	The LED flashes red/green. "ERROR" and "bar" flash in the display.	Restart after error confirmation and pressing the "Start/Stop" button, or on an automatic restart attempt.
Diaphragm leakage detection (optional).	Diaphragm leakage.	The pump starts running again (in emergency mode).	The LED flashes red. "ERROR" and "MBS" (MLS) flash in the display. The error signal relay switches on.	The error signal relay switches off after error confirmation.
Flow Monitor (dosing controller).	See section 9.10 <i>Flow Monitor</i> .			

10. Maintenance

10.1 General notes

Warning

When dosing dangerous media, observe the corresponding safety precautions!

Risk of chemical burns!

Wear protective clothing (gloves and goggles) when working on the dosing head, connections or lines!

Do not allow any chemicals to leak from the pump. Collect and dispose of all chemicals correctly!

Warning

The pump housing must only be opened by personnel authorised by Grundfos Alldos! Repairs must only be carried out by authorised and qualified personnel!

Switch off the pump and disconnect it from the power supply before carrying out maintenance work and repairs!



10.2 Maintenance intervals

In the event of a diaphragm leakage, the dosing liquid may leak out of the hole in the intermediate flange between the pump and the dosing head. The parts inside the housing are protected from the dosing liquid for a short time (depending on the type of liquid) by the housing sealing. It is necessary to check regularly (daily) if liquid is leaking out of the intermediate flange.

Caution

For maximum safety, we recommend the pump version with diaphragm leakage detection.

- At least every 12 months or after 4,000 operating hours. When dosing crystallising liquids, more frequently.
- In the event of a fault.

10.2.1 Cleaning the valves and diaphragm

- Clean the diaphragm and valves and replace, if necessary (for stainless-steel valves: inner valve parts).

10.3 Cleaning suction and discharge valves

Note

If possible, rinse the dosing head, e.g. by supplying it with water.

10.3.1 Switching off the pump

1. Switch off the pump and disconnect it from the power supply.
2. Depressurise the system.
3. Take suitable steps to ensure that the returning dosing medium is safely collected.

10.3.2 Unscrewing suction and discharge valves/cleaning valves

1. Unscrew the suction and discharge valves.
2. Remove the screw part and valve seat with round nose pliers.
3. Dismantle the inner part (seat, O-ring, balls, ball cages and, if present, springs).
4. Clean all parts. Replace faulty parts by new ones.
 - For plastic DN 8 valve, replace the valve completely.
 - For stainless-steel DN 8 valve or DN 20 valve, replace the inner valve parts.
5. Re-assemble the valve.
6. Replace the O-rings by new ones. Refit the valve.

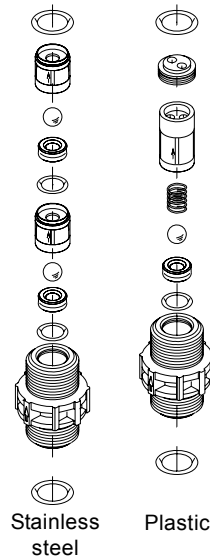

Fig. 54 Stainless-steel or plastic DN 20 valve, spring-loaded as an option

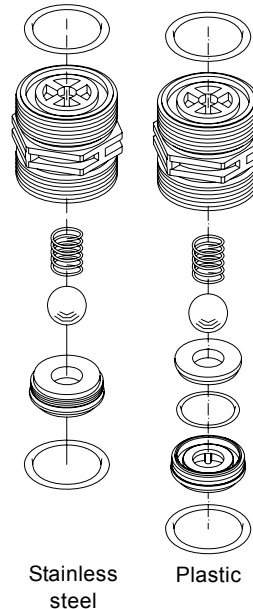

Fig. 55 Stainless-steel or plastic DN 20 valve, spring-loaded as an option

The O-rings must be correctly placed in the specified groove.

Caution

Observe the flow direction (indicated by an arrow)!

Only tighten the valve by hand.

10.4 Replacing the diaphragm



Warning

Risk of chemical burns!

Wear protective clothing (gloves and goggles) when working on the dosing head, connections or lines!

Do not allow any chemicals to leak from the pump. Collect and dispose of all chemicals correctly!

Note

If possible, rinse the dosing head, e.g. by supplying it with water.

10.4.1 Resetting the diaphragm

When replacing the diaphragm, it must be at the back dead point (end of suction stroke). As the stroke usually ends at the front dead point, reset the diaphragm as follows:

- With the pump stopped (LED lights up red), press the "Up" and "Down" buttons simultaneously.
 - The diaphragm is reset.

10.4.2 Switching off the pump

1. Switch off the pump and disconnect it from the power supply.
2. Depressurise the system.
3. Take suitable steps to ensure that the returning dosing medium is safely collected.

10.4.3 Replacing the diaphragm

See fig. 56 or 57.

1. Loosen the six screws (1q) on the dosing head (2).
2. Remove the dosing head (2) with dosing head disk (2q).
3. Unscrew the diaphragm (Q) counter-clockwise.
4. Screw in the new diaphragm (Q).
 - For pumps with diaphragm leakage detection: Screw in the complete diaphragm package.
5. Replace the dosing head (2) with dosing head disk (2q) and cross-tighten the screws (1q).
Torque: 7 Nm (+ 1 Nm).
6. Restart the dosing pump.

After initial start-up and after each time the diaphragm is changed, tighten the dosing head screws.

Caution

After approximately 6-10 operating hours or two days, cross-tighten the dosing head screws using a torque wrench.

Torque: 7 Nm (+ 1 Nm).

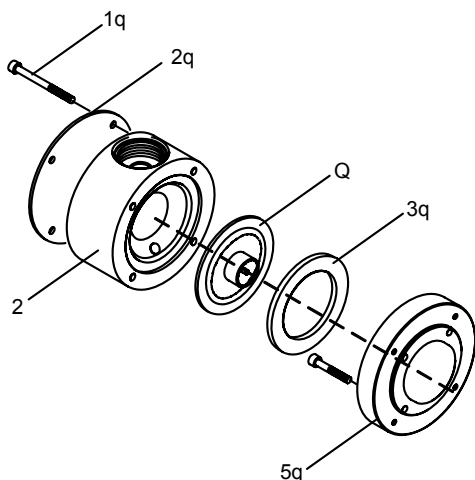

Fig. 56 Replacing the diaphragm for DDI 60-10

TM03 6687 4506

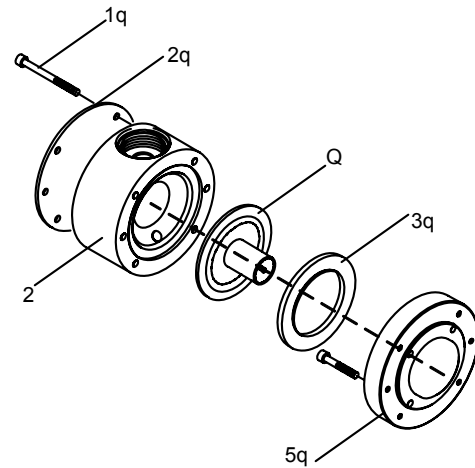

Fig. 57 Replacing the diaphragm for DDI 150-4

Pos.	Components
Q	Diaphragm (package)
2	Dosing head
1q	Dosing head screws
2q	Dosing head disk
3q	Intermediate ring
5q	Intermediate flange

TM03 6688 4506

11. Fault finding chart

Fault	Cause	Remedy
1. Dosing pump does not run.	a) Not connected to the mains.	Connect the power supply cable.
	b) Incorrect mains voltage.	Switch off the pump. Check voltage and motor. If the motor is faulty, return the pump for repair.
	c) Electrical failure.	Return the pump for repair.
2. Pump does not suck in or dose.	a) Crystalline deposits in the valves.	Clean the valves.
	b) Empty dosing tank.	Fill dosing tank.
	c) Air in the suction line and dosing head.	Fill dosing head and suction line.
	d) Valves not correctly assembled.	Assemble the valve inner parts in the right order and check or possibly correct the flow direction.
3. Dosing pump does not suck in.	a) Leaking suction line.	Replace or seal the suction line.
	b) Cross-section of the suction line too small or suction line too long.	Check with Grundfos Alldos specification.
	c) Clogged suction line.	Rinse or replace the suction line.
	d) Foot valve covered by sediment.	Suspend the suction line from a higher position.
	e) Buckled suction line.	Install the suction line correctly. Check for damage.
	f) Crystalline deposits in the valves.	Clean the valves.
	g) Diaphragm broken or diaphragm tappet torn out.	Replace the diaphragm.
	h) Excess counter-pressure.	Depressurise the system on the discharge side of the pump.
	i) Empty dosing tank.	Fill the dosing tank.
	4. Dosing pump does not dose.	a) Viscosity or density of medium too high.
b) Crystalline deposits in the valves.		Clean the valves.
c) Valves not correctly assembled.		Assemble the inner valve parts in the right order and check or possibly correct the flow direction.
d) Injection unit blocked.		Check and possibly correct the flow direction, or remove the obstruction.
e) Incorrect installation of lines and peripheral equipment.		Check the lines for free passage and correct installation.
f) Empty dosing tank.		Fill the dosing tank.
g) Sealing elements not chemically resistant.		Replace sealing elements.
5. Dosing flow of the pump is inaccurate.		a) Degassing medium.
	b) Parts of the valves covered in dirt or incrusted.	Clean the valves.
	c) Incorrect dosing flow display.	Calibrate.
	d) Counter-pressure fluctuations.	Install a pressure-loading valve and a pulsation damper, if necessary.
	e) Suction lift fluctuations.	Keep the suction level constant.
	f) Siphon effect (inlet pressure higher than counter-pressure).	Install a pressure-loading valve.
	g) Leaking or porous suction line or discharge line.	Replace the suction line or discharge line.
	h) Parts in contact with the medium are not resistant to it.	Replace with resistant materials.
	i) Dosing diaphragm worn (incipient tears).	Replace the diaphragm. Also observe the maintenance instructions.
	j) Variation of the dosing medium (density, viscosity).	Check the concentration. Use an agitator, if necessary.
	k) Overflow.	Install or check suction and pressure pulsation damper, recalculate installation, install a pressure-loading valve.
6. Liquid leaks out of the hole in the intermediate flange between the pump and the dosing head.	a) A diaphragm leakage has occurred.	Replace the diaphragm.

Note For further error signals for the control unit, refer to the relevant section.

12. Disposal

This product or parts of it must be disposed of in an environmentally sound way:

1. Use appropriate waste collection services.
2. If this is not possible, contact the nearest Grundfos or Grundfos Alldos company or service workshop.

Safety declaration

Please copy, fill in and sign this sheet and attach it to the pump returned for service.

We hereby declare that this product is free from hazardous chemicals, biological and radioactive substances:

Product type: _____

Model number: _____

No media or water: _____

A chemical solution, name: _____

(see pump nameplate)

Fault description

Please make a circle around the damaged part.
In the case of an electrical or functional fault, please mark the cabinet.



GrA3502

Please give a short description of the fault:

Date and signature

Company stamp

Argentina
Bombas GRUNDFOS de Argentina S.A.
Ruta Panamericana km. 37.500 Lote 34A
1619 - Garin
Pcia. de Buenos Aires
Phone: +54-3327 414 444
Telefax: +54-3327 411 111

Australia
Grundfos Alldos
Dosing & Disinfection
ALLDOS Oceania Pty. Ltd.
Unit 3 / 74 Murdoch Circuit
Acacia Ridge QLD 4100
Phone: +61 (0)7 3712 6888
Telefax: +61 (0)7 3272 5188
E-mail: alldos.au@alldos.com

Australia
GRUNDFOS Pumps Pty. Ltd.
P.O. Box 2040
Regency Park
South Australia 5942
Phone: +61-8-8461-4611
Telefax: +61-8-8340 0155

Austria
GRUNDFOS Pumpen Vertrieb Ges.m.b.H.
Grundfosstraße 2
A-5082 Grödig/Salzburg
Tel.: +43-6246-883-0
Telefax: +43-6246-883-30

Belgium
N.V. GRUNDFOS Bellux S.A.
Boomsesteenweg 81-83
B-2630 Aartselaar
Tél.: +32-3-870 7300
Télécopie: +32-3-870 7301

Belorussia
Представительство ГРУНДФОС в Минске
220090 Минск ул.Олешева 14
Телефон: (8632) 62-40-49
Факс: (8632) 62-40-49

Bosnia/Herzegovina
GRUNDFOS Sarajevo
Paromlinska br. 16,
BiH-71000 Sarajevo
Phone: +387 33 713290
Telefax: +387 33 231795

Brazil
Mark GRUNDFOS Ltda.
Av. Humberto de Alencar Castelo Branco,
630
CEP 09850 - 300
São Bernardo do Campo - SP
Phone: +55-11 4393 5533
Telefax: +55-11 4343 5015

Bulgaria
GRUNDFOS Pumpen Vertrieb
Representative Office - Bulgaria
Bulgaria, 1421 Sofia
Lozenez District
105-107 Arsenalski blvd.
Phone: +359 2963 3820, 2963 5653
Telefax: +359 2963 1305

Canada
GRUNDFOS Canada Inc.
2941 Brighton Road
Oakville, Ontario
L6H 6C9
Phone: +1-905 829 9533
Telefax: +1-905 829 9512

China
Grundfos Alldos
Dosing & Disinfection
ALLDOS (Shanghai) Water Technology Co.
Ltd.
West Unit, 1 Floor, No. 2 Building (T 4-2)
278 Jinhua Road, Jin Qiao Export Processing
Zone
Pudong New Area
Shanghai, 201206
Phone: +86 21 5055 1012
Telefax: +86 21 5032 0596
E-mail: alldos.cn@alldos.com

China
GRUNDFOS Pumps (Shanghai) Co. Ltd.
22 Floor, Xin Hua Lian Building
755-775 Huai Hai Rd, (M)
Shanghai 200020
PRC
Phone: +86-512-67 61 11 80
Telefax: +86-512-67 61 81 67

Croatia
GRUNDFOS predstavništvo Zagreb
Cebini 37, Buzin
HR-10000 Zagreb
Phone: +385 1 6595 400
Telefax: +385 1 6595 499

Czech Republic
GRUNDFOS s.r.o.
Čapkovského 21
779 00 Olomouc
Phone: +420-585-716 111
Telefax: +420-585-716 299

Denmark
GRUNDFOS DK A/S
Martin Bachs Vej 3
DK-8850 Bjerringbro
Tlf.: +45-87 50 50 50
Telefax: +45-87 50 51 51
E-mail: info_GDK@grundfos.com
www.grundfos.com/DK

Estonia
GRUNDFOS Pumps Eesti OÜ
Peterburi tee 92G
11415 Tallinn
Tel: + 372 606 1690
Fax: + 372 606 1691

Finland
OY GRUNDFOS Pumput AB
Mestarintie 11
FIN-01730 Vantaa
Phone: +358-3066 5650
Telefax: +358-3066 56550

France
Grundfos Alldos
Dosing & Disinfection
ALLDOS S.A.R.L.
7, rue Gutenberg
F-67610 La Wantzenau
Tél.: +33-3 88 59 26 26
Télécopie: +33-3 88 59 26 00
E-mail : alldos.fr@alldos.com

France
Pompes GRUNDFOS Distribution S.A.
Parc d'Activités de Chesnes
57, rue de Malacombe
F-38290 St. Quentin Fallavier (Lyon)
Tél.: +33-4 74 82 15 15
Télécopie: +33-4 74 94 10 51

Germany
Grundfos Alldos
Dosing & Disinfection
ALLDOS Eichler GmbH
Reetzstraße 85
D-76327 Pfintzal (Söllingen)
Tel.: +49 7240 61-0
Telefax: +49 7240 61-177
E-mail: alldos.de@alldos.com

Germany
GRUNDFOS GMBH
Schlüterstr. 33
D-40699 Erkrath
Tel.: +49-(0) 211 929 69-0
Telefax: +49-(0) 211 929 69-3799
E-mail: infoservice@grundfos.de
Service in Deutschland:
E-mail: kundendienst@grundfos.de

Greece
GRUNDFOS Hellas A.E.B.E.
20th km. Athinon-Markopoulou Av.
P.O. Box 71
GR-19002 Peania
Phone: +0030-210-66 83 400
Telefax: +0030-210-66 46 273

Hong Kong
GRUNDFOS Pumps (Hong Kong) Ltd.
Unit 1, Ground floor
Siu Wai Industrial Centre
29-33 Wing Hong Street &
68 King Lam Street, Cheung Sha Wan
Kowloon
Phone: +852-27861706 / 27861741
Telefax: +852-27858664

Hungary
GRUNDFOS Hungária Kft.
Park u. 8
H-2045 Törökbálint,
Phone: +36-23 511 110
Telefax: +36-23 511 111

India
GRUNDFOS Pumps India Private Limited
118 Old Mahabalipuram Road
Thoraiakkam
Chennai 600 096
Phone: +91-44 2496 6800

Indonesia
PT GRUNDFOS Pompa
Jl. Rawa Sumur III, Blok III / CC-1
Kawasan Industri, Pulogadung
Jakarta 13930
Phone: +62-21-460 6909
Telefax: +62-21-460 6910 / 460 6901

Ireland
GRUNDFOS (Ireland) Ltd.
Unit A, Merrywell Business Park
Ballymount Road Lower
Dublin 12
Phone: +353-1-4089 800
Telefax: +353-1-4089 830

Italy
GRUNDFOS Pompe Italia S.r.l.
Via Gran Sasso 4
I-20060 Truccazzano (Milano)
Tel.: +39-02-95838112
Telefax: +39-02-95309290 / 95838461

Japan
GRUNDFOS Pumps K.K.
Gotanda Metalion Bldg. 5F,
5-21-15, Higashi-gotanda
Shiagawa-ku, Tokyo,
141-0022 Japan
Phone: +81 35 448 1391
Telefax: +81 35 448 9619

Korea
GRUNDFOS Pumps Korea Ltd.
6th Floor, Aju Building 679-5
Yeoksam-dong, Kangnam-ku, 135-916
Seoul, Korea
Phone: +82-2-5317 600
Telefax: +82-2-5633 725

Latvia
SIA GRUNDFOS Pumps Latvia
Deglava biznesa centrs
Augusta Deglava ielā 60, LV-1035, Rīga,
Tālr.: + 371 714 9640, 7 149 641
Fakss: + 371 914 9646

Lithuania
GRUNDFOS Pumps UAB
Smolensko g. 6
LT-03201 Vilnius
Tel: + 370 52 395 430
Fax: + 370 52 395 431

Malaysia
GRUNDFOS Pumps Sdn. Bhd.
7 Jalan Peguam U1/25
Glenmarie Industrial Park
40150 Shah Alam
Selangor
Phone: +60-3-5569 2922
Telefax: +60-3-5569 2866

México
Bombas GRUNDFOS de México S.A. de
C.V.
Boulevard TLC No. 15
Parque Industrial Stiva Aeropuerto
Apodaca, N.L. 66600
Phone: +52-81-8144 4000
Telefax: +52-81-8144 4010

Netherlands
Grundfos Alldos
Dosing & Disinfection
ALLDOS BV
Leerlooiersstraat 6
NL-8601 WK Sneek
Tel.: +31-51 54 25 789
Telefax: +31-51 54 30 550
E-mail: alldos.nl@alldos.com

Netherlands
GRUNDFOS Netherlands
Veluwezoom 35
1326 AE Almere
Postbus 22015
1302 CA ALMERE
Tel.: +31-88-478 6336
Telefax: +31-88-478 6332
e-mail: info_gnl@grundfos.com

New Zealand
GRUNDFOS Pumps NZ Ltd.
17 Beatrice Tinsley Crescent
North Harbour Industrial Estate
Albany, Auckland
Phone: +64-9-415 3240
Telefax: +64-9-415 3250

Norway
GRUNDFOS Pumper A/S
Strømsveien 344
Postboks 235, Leirdal
N-1011 Oslo
Tlf.: +47-22 90 47 00
Telefax: +47-22 32 21 50

Poland
GRUNDFOS Pompy Sp. z o.o.
ul. Klonowa 23
Baranowo k. Poznania
PL-62-081 Przeźmierowo
Tel: (+48-61) 650 13 00
Fax: (+48-61) 650 13 50

Portugal
Bombas GRUNDFOS Portugal, S.A.
Rua Calvet de Magalhães, 241
Apartado 1079
P-2770-153 Paço de Arcos
Tel.: +351-21-440 76 00
Telefax: +351-21-440 76 90

România
GRUNDFOS Pompe România SRL
Bd. Biruintei, nr 103
Pantelimon county Ilfov
Phone: +40 21 200 4100
Telefax: +40 21 200 4101
E-mail: romania@grundfos.ro

Russia
ООО Грундфос
Россия, 109544 Москва, ул. Школьная 39
Тел. (+7) 495 737 30 00, 564 88 00
Факс (+7) 495 737 75 36, 564 88 11
E-mail grundfos.moscow@grundfos.com

Serbia
GRUNDFOS Predstavništvo Beograd
Dr. Milutina Ivkovića 2a/29
YU-11000 Beograd
Phone: +381 11 26 47 877 / 11 26 47 496
Telefax: +381 11 26 48 340

Singapore
GRUNDFOS (Singapore) Pte. Ltd.
24 Tuas West Road
Jurong Town
Singapore 638381
Phone: +65-6865 1222
Telefax: +65-6861 8402

Slovenia
GRUNDFOS PUMPEN VERTRIEB
Ges.m.b.H.,
Podružnica Ljubljana
Blatnica 1, SI-1236 Trzin
Phone: +386 1 563 5338
Telefax: +386 1 563 2098
E-mail: slovenia@grundfos.si

South Africa
Grundfos Alldos
Dosing & Disinfection
ALLDOS (Pty) LTD
98 Matroosberg Road, Waterkloof Park
P.O. Box 36505, Menlo Park 0102
0181 ZA Pretoria
E-mail: alldos.za@alldos.com

Spain
Bombas GRUNDFOS España S.A.
Camino de la Fuentequilla, s/n
E-28110 Algete (Madrid)
Tel.: +34-91-848 8800
Telefax: +34-91-628 0465

Sweden
GRUNDFOS AB
(Box 333) Lunnagårdsgatan 6
431 24 Mölndal
Tel.: +46(0)771-32 23 00
Telefax: +46(0)31-331 94 60

Switzerland
Grundfos Alldos
Dosing & Disinfection
ALLDOS International AG
Schönmattdstraße 4
CH-4153 Reinach
Tel.: +41-61-717 5555
Telefax: +41-61-717 5500
E-mail: alldos.ch@alldos.com

Switzerland
GRUNDFOS Pumpen AG
Bruggacherstrasse 10
CH-8117 Fällanden/ZH
Tel.: +41-1-806 8111
Telefax: +41-1-806 8115

Taiwan
GRUNDFOS Pumps (Taiwan) Ltd.
7 Floor, 219 Min-Chuan Road
Taichung, Taiwan, R.O.C.
Phone: +886-4-2305 0868
Telefax: +886-4-2305 0878

Thailand
GRUNDFOS (Thailand) Ltd.
92 Chaloom Phrakiat Rama 9 Road,
Dokmai, Pravej, Bangkok 10250
Phone: +66-2-725 8999
Telefax: +66-2-725 8998

Turkey
GRUNDFOS POMPA San. ve Tic. Ltd. Sti.
Gebze Organize Sanayi Bölgesi
Ihsan dede Caddesi,
2. yol 200. Sokak No. 204
41490 Gebze/ Kocaeli
Phone: +90 - 262-679 7979
Telefax: +90 - 262-679 7905
E-mail: satis@grundfos.com

Ukraine
ТОВ ГРУНДФОС УКРАЇНА
01010 Київ, Вул. Московська 86,
Тел.:(+38 044) 390 40 50
Факс: (+38 044) 390 40 59
E-mail: ukraine@grundfos.com

United Arab Emirates
GRUNDFOS Gulf Distribution
P.O. Box 16768
Jebel Ali Free Zone
Dubai
Phone: +971-4- 8815 166
Telefax: +971-4-8815 136

United Kingdom
Grundfos Alldos
Dosing & Disinfection
ALLDOS Ltd.
39 Gravelly Industrial Park, Tyburn Road
Birmingham B24 8TG
Phone: +44-121-3283336
Telefax: +44-121-3284332
E-mail: alldos.uk@alldos.com

United Kingdom
GRUNDFOS Pumps Ltd.
Grovebury Road
Leighton Buzzard/Beds. LU7 8TL
Phone: +44-1525-850000
Telefax: +44-1525-850011

U.S.A.
GRUNDFOS Pumps Corporation
17100 West 118th Terrace
Olathe, Kansas 66061
Phone: +1-913-227-3400
Telefax: +1-913-227-3500

Usbekistan
Представительство ГРУНДФОС в
Ташкенте
700000 Ташкент ул.Усмана Носира 1-й
тулик 5
Телефон: (3712) 55-68-15
Факс: (3712) 53-36-35

15. 720139 V5.0 Repl. 15.720139 V4.0	GB
96690281 0408	