

Bohrbild identisch, somit ist ein um 180° gedrehter Einbau möglich.

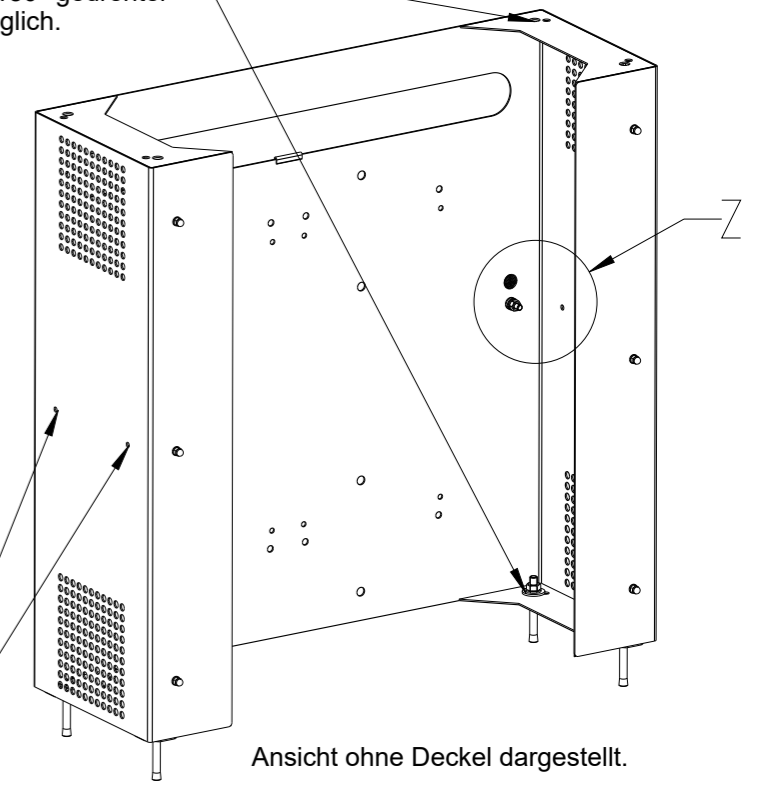

Position für PA-Schiene

Ansicht ohne Deckel dargestellt.

Diese Zeichnung ist geistiges Eigentum der Fa. HUBER SE und damit urheberrechtlich geschützt. Zuwiderhandlungen verpflichten zum Schadensersatz.
This is a copyrighted drawing which is the intellectual property of HUBER SE.
Any contravening offender will be held liable for payment of damages.

HUBER
TECHNOLOGY

WASTE WATER Solutions
D-92334 Berching / Tel.: +49-8462-201-0

Technische Änderungen vorbehalten / Subject to change

ISO 2768-mK

Rev.	Änderung	Tag	Name	Norm.	Datum/Date	Name
					Bear./Rev.	24.11.11 rba
c	Änd.3756	29.01.24	km		Gep./Appr.	22.07.2022 wop

Schaltschranksockel

control panel base

W 800 t 284 H 800

Projekt
project



Production drawing

Massstab
scale

1:10

Nummer
number

Blatt
sheet

1/1

301315