



frenomat[®] und frenostat[®] **Electronic Brake Units**

The quick and reliable way to bring things to a standstill
– with no mechanical wear



Hilger u. Kern **Industrieelektronik**

Contents

	Page
General information	3
• cUL approval	3
• EU Declaration of Conformity	3
• Line choke	3
• Certification of mechanical stability	3
Application / Operating principle	4
frenomat 2 brake unit	5
frenostat 1000 brake unit	6
frenostat 2000 brake unit	7
Technical data: frenomat 2/frenostat 2000 brake units	9
Dimensions: frenostat 2000	10
Examples of circuits: frenostat 2000	11-14
Accessory: line choke	14
Commissioning: frenomat 2/frenostat 2000	15
International sales organization	15

General information

cUL approval frenostat and frenomat brake units listed at Underwriters Laboratories Inc.

Important for all export-oriented companies:

As of immediately, all frenostat and frenomat brake units from Hilger u. Kern Industrieelektronik are cUL listed. The UL File Number is 225692 and the Control No. is 1 Y D 1.

Listed units with UL makes it easier to export machinery and installations to the USA and Canada.

The UL-listed Size 2 is made of sheet steel and the line choke is integrated in the unit. Size 1 (36 and 60 A) is now supplied as a new plastic version.

EU Declaration of Conformity

Hilger u. Kern Industrieelektronik here with declares with respect to the products it manufactures and named below

frenomat electronic brake unit, frenostat electronic brake unit,

that the requirements relating to electromagnetic compatibility (EMC) as laid down in EU Directive 89/336/EEC are met.

Assessment of the product has been based on the following standards:

- IEC 947-4-2 AC semiconductor motor controllers and starters

- EN 50081-1 Generic Emission Standard 03.93

- EN 50082-2 Generic Immunity Standard 08.94

The corresponding measurements have been confirmed and documented by the German technical inspectorate TÜV-Südwest in Mannheim.

The units named above are labeled with a CE mark of conformity.

Line choke

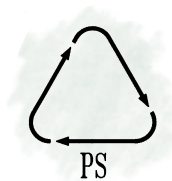

The emission limits laid down in the European standards do not exclude interference of receivers within a radius of 10 m.

During operation, i.e. braking, frenostat and frenomat electronic brake units remain within the limits of European standard EN 50081-2 (mains-borne interference) with regard to the power cables if a line choke

is installed directly on the line terminal. This accessory is available from Hilger u. Kern Industrieelektronik (see page 14). The enclosures of the frenostat brake units are made of environmentally friendly, recyclable materials.

Certification of mechanical stability

frenostat electronic brake unit No. 12524100 has been subjected to a type test in accordance with DIN 57 Part 2/VDE 0160 Part 2, Section 4.2.

This test is valid for all frenostat brake units that have been manufactured since January 1, 1978.

The results of the measurements taken

have revealed that the brake unit more than complies with the requirements laid down in VDE 0160 Part 2, Section 4.2.

Operational reliability of the frenostat brake unit was unaffected.

Application / Operating principle

frenomat and frenostat electronic brake units

- reliably and quickly brake asynchronous motors to a standstill without requiring any maintenance or suffering any wear.
- are the perfect solution for shortening long coasting times (saving time and costs).
- are components that can be retrofitted in control cabinets without any problem.
- are maintenance- and wear-free.

Due to systematic action taken to meet the demands of the market, frenomat and frenostat electronic brake units have a

wider power spectrum than units comparable in design. In particular, the following features designed to increase service reliability must be highlighted:

- visual indication of the operating state
- proven snubber circuit to protect against voltage peaks
- generous rating of the heat sinks
- high degree of service reliability – even under rough service and ambient conditions – thanks to protective lacquering
- captive connecting screws
- automatic standstill monitoring.

Basic circuitry of the main circuit (basic layout) ►

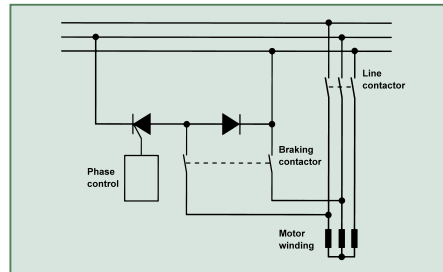

Braking torque curve with asynchronous motors as a factor of the speed ►►

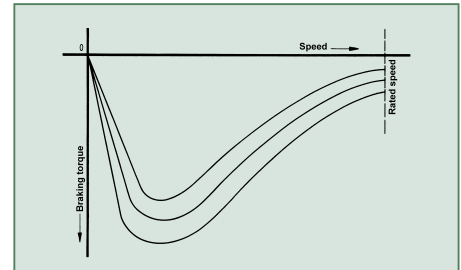

Operating principle

A rugged power converter, working in conjunction with floating, digital control electronics, generates a powerful braking torque.

The braking effect is initiated by an adjustable direct current that flows through

the motor winding. A stationary magnetic field, which acts as a static field, retards the rotational movement of the rotor. The braking torque that results from this follows the curve depicted against the speed.

Application example: vibrating screen



A frenostat 2000 electronic brake unit brings the 30-kW drive to a standstill within just a few seconds. This prevents dangerous sympathetic (resonant) oscillations. Use of the frenostat 2000 made it possible to do without elaborate and costly concrete foundations.

frenomat 2 electronic brake unit

The frenomat 2 electronic brake unit quickly and reliably brakes three-phase AC motors with a power output of up to 3 kW. frenomat 2 brake units are compact and suitable for snap-fitting on DIN rails. They are only 55 mm wide!

The control and power circuits are housed in a rigid and unbreakable plastic enclosure. The braking current and braking time are both infinitely variable and can be adjusted manually.

frenomat 2 is also equipped with a standstill monitoring unit on terminal n1 to allow it to be used with drives whose rotating mass is frequently changed.

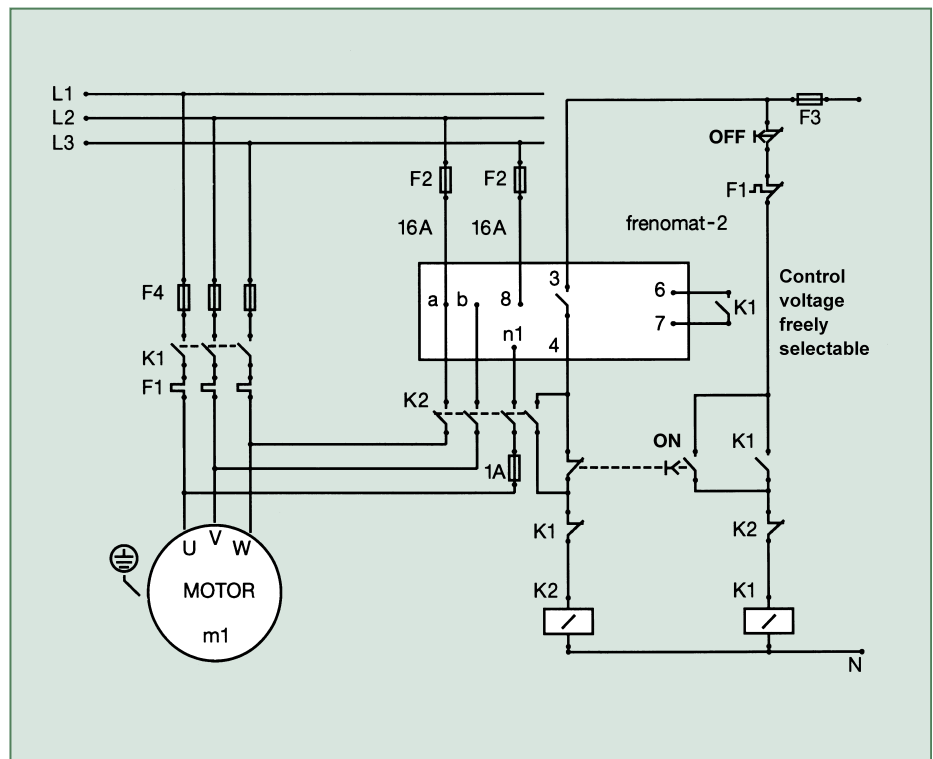

Circuit diagram ►

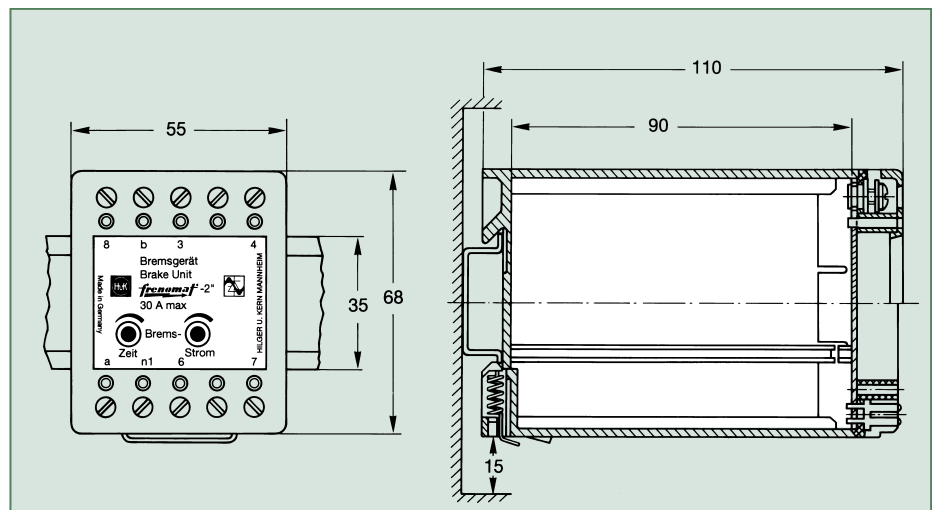

Dimensions ►

frenostat 2000 electronic brake unit



This type of brake unit is used to quickly and reliably brake three-phase AC motors within a power output range from 3 to 100 kW to a standstill. frenostat 2000 is available in 4 different sizes.

Braking current control



The frenostat 2000 braking units use an integral braking current measurement function to control the amperage and the braking force to the specified values set. This simplifies commissioning and dis-

penses with the need for time-consuming measurement procedures. An ammeter is not required to set the current. The current level is indicated by means of a bar display.

Control / Status indicators

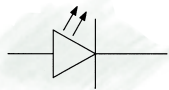

All important operating statuses are indicated by means of LEDs.

- ① "P" – Fuse monitoring
- ② "M" – Motor On
- ③ "B" – Brake active
- ④ "S" – Standstill monitoring by sensing the motor's rotational movement
- ⑤ "O" – Overheating indicator flashes
- ⑥ Potentiometer for time adjustment
- ⑦ Potentiometer for braking current adjustment
- ⑧ Braking current display

frenostat 2000 electronic brake units can be controlled both by means of contactor equipment or a PLC. (24-V logic)

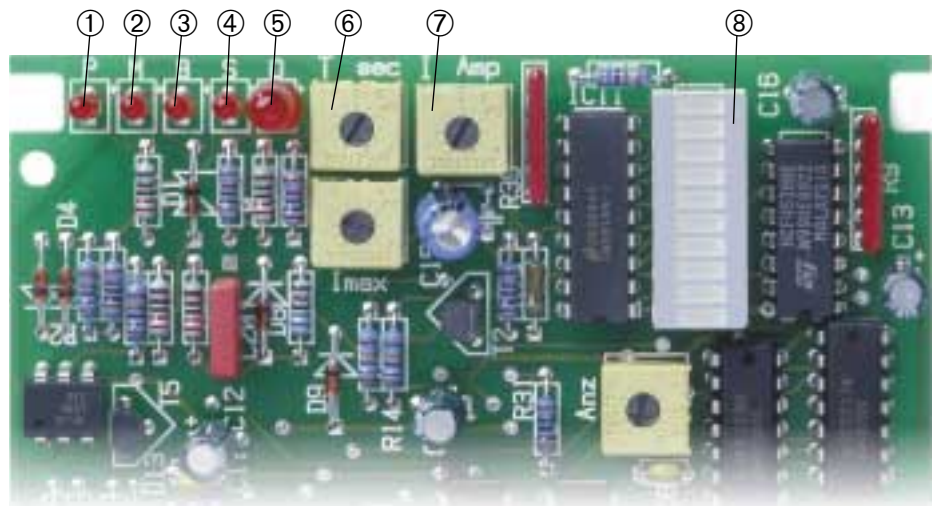

Braking current display

LED



LED frenostat 2000 brake units are equipped with an LED bar display

This display indicates the instantaneous braking current in 10% steps.

Overheating protection

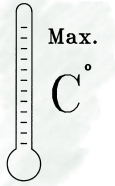

In order to increase operational reliability, frenostat 2000 brake units are equipped with an integral temperature-measuring function.

In the event of the unit overheating, due to too frequent braking for example, braking is executed until the motor comes to a standstill, but the motor is prevented from

restarting. A floating relay contact (n_3, n_4) remains closed. In addition, LED "O" flashes to indicate overheating. Once the brake unit has cooled down to its normal operating temperature, the relay contact (n_3, n_4) is opened again. LED "O" stops flashing.

Standstill monitoring

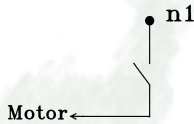

An integrated standstill monitoring unit alters the operating time of the brake depending on the variable rotating mass of the overall drive. A manual time setting is not needed.

Activation of this monitoring unit is indicated by LED "S".

The control unit is connected to terminal n_1 by means of an instrument lead (0.75 mm^2). Measurement is triggered by the braking contactor by means of an auxiliary contact. If motor leads with a cross-section $>1.5 \text{ mm}^2$ are used, a 2-A fuse must be fitted to protect the instrument lead.

Interlocking contact

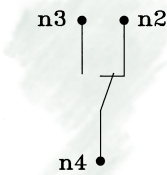

frenostat brake units are equipped with a floating changeover contact. NC contact $n_4 - n_2$ opens after the motor has started and in this way allows the motor to be started again only after braking has been completed.

The interlocking contact can perform the following functions:

- protect against overheating
- interlock immediate reclosure following the OFF command without braking (see

examples of circuits)

- indicate readiness: the motor is only released by a PLC for reclosure once the contact is in its normal position
- interlock a hood or cover: a protective hood or cover can only be opened when the drive is at rest
- report standstill
- open a mechanical holding brake.

Choice of brake unit fuses

The 2 brake unit fuses serve among other things to protect the motor against overloading. These fuses must be adapted to match the rated current of the motor.

Rated fuse current = approx. 150% of rated motor current. See basic circuit on page 13 for circuitry of fuse F4.

Choice of braking contactor

Size of braking contactor = size of motor contactor. The contactor is energized and

de-energized without current being applied to the main contacts.

Size of connection cables

The cross-section of the cables connected to terminals 8, a and b is identical to that of the motor connection cables.

The cable connected to terminal n_1 is an instrument lead ($<1 \text{ A}$); a cross-section of 0.75 mm^2 is sufficient.

Braking current rating

The motor current (I_M) must be known before the necessary braking current (I_B) can be rated:

$$I_B = 3 \times I_M$$

$I_B \hat{=}$ necessary braking current in amperes

$I_M \hat{=}$ rated motor current in amperes

The braking current should be more than 3 times higher than the rated motor current. When placing an order, only the braking current amperage and the line voltage should be specified.

The maximum braking current of the various sizes of brake unit can be found in the table on page 9.

Order text:

frenostat 2000 Size 2
Braking current 100 A
Line voltage 400 V

frenomat 2/frenostat 1000/frenostat 2000 electronic brake units

Technical data

Maximum braking current:	frenomat 2	30 A
	frenostat 1000	25, 40, 60 A
	frenostat 2000 Size 1	36, 60 A
	frenostat 2000 Size 2	100, 150, 200 A
	frenostat 2000 Size 3	300, 400, 500 A
	frenostat 2000 Size 4	750, 1000, 1500 A

Input braking voltage: 230 V to 500 V
+ 10% / - 15% at 50 to 60 Hz higher than 500 V on request

Max. output braking voltage: (V) DC	Line voltage AC	Braking current DC
	230 V	80 V
400 V	160 V	
500 V	190 V	
660 V	270 V	

Ambient temperature: - 25°C to + 45°C at nominal output; between + 45°C braking current of 1.5%
and + 60°C, reduction in at temperatures necessary per °C

Contact load: 250 V / 5 A (at terminals 3 and 4)

Braking time: 0 to 12 seconds; time is set automatically unit is connected
when a standstill monitoring the braking to terminal n-/T3

ON time: 20% in relation to 1 min. (12 s/min.) Please inquire about longer ON times

External fuses: frenomat – max. 16 A
frenostat – approx. 150%
of rated motor current

Dimensions

frenostat 2000 Size 1

36 A and 60 A

Height x width x depth
185 x 158 x 110 mm

Drilling dimensions in mm
145 x 137 \varnothing 5.5 mm

Weight: 1.1 kg

Line choke for assembly outside the unit (optional) ▶

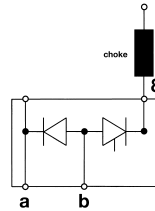

frenostat 2000 Size 2

100 A, 150 A and 200 A

Height x width x depth
270 x 145 x 180 mm

Drilling dimensions in mm
130 x 215 \varnothing 6.5 mm

Weight: 7.5 kg

Line choke installed in unit ▶

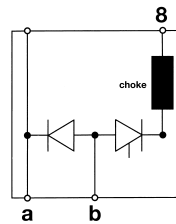

frenostat 2000 Size 3

300 A, 400 A and 500 A

Height x width x depth
270 x 145 x 180 mm

Drilling dimensions in mm
130 x 215 \varnothing 6.5 mm

Weight: 6.5 kg

Line choke separate outside the unit ▶

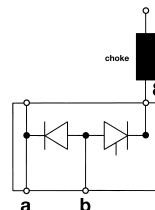

Examples of circuits: frenostat 2000 electronic brake unit

Circuit diagram 1

▼ Basic circuit

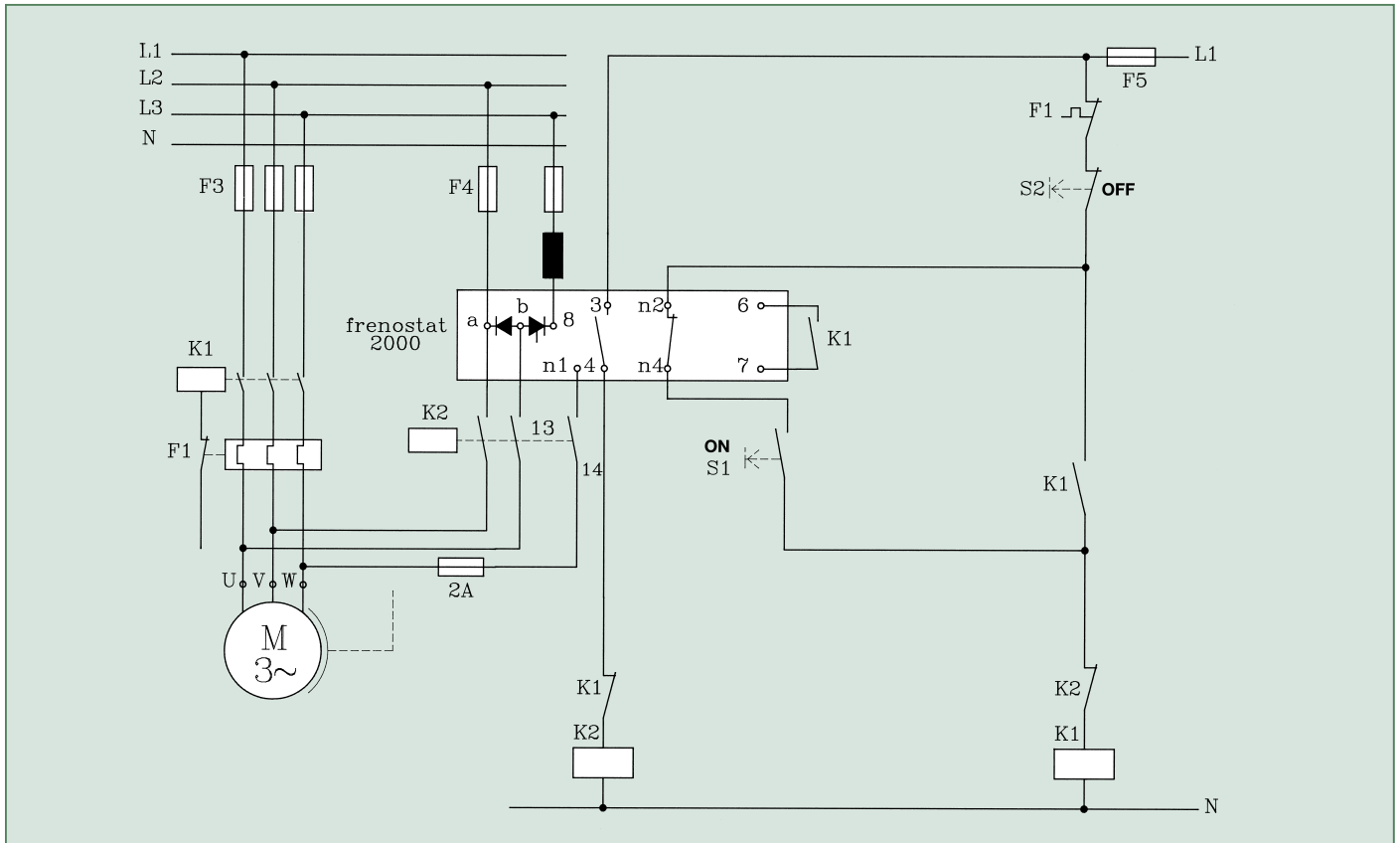

Circuit diagram 2

▼ Motor control for reversing operation

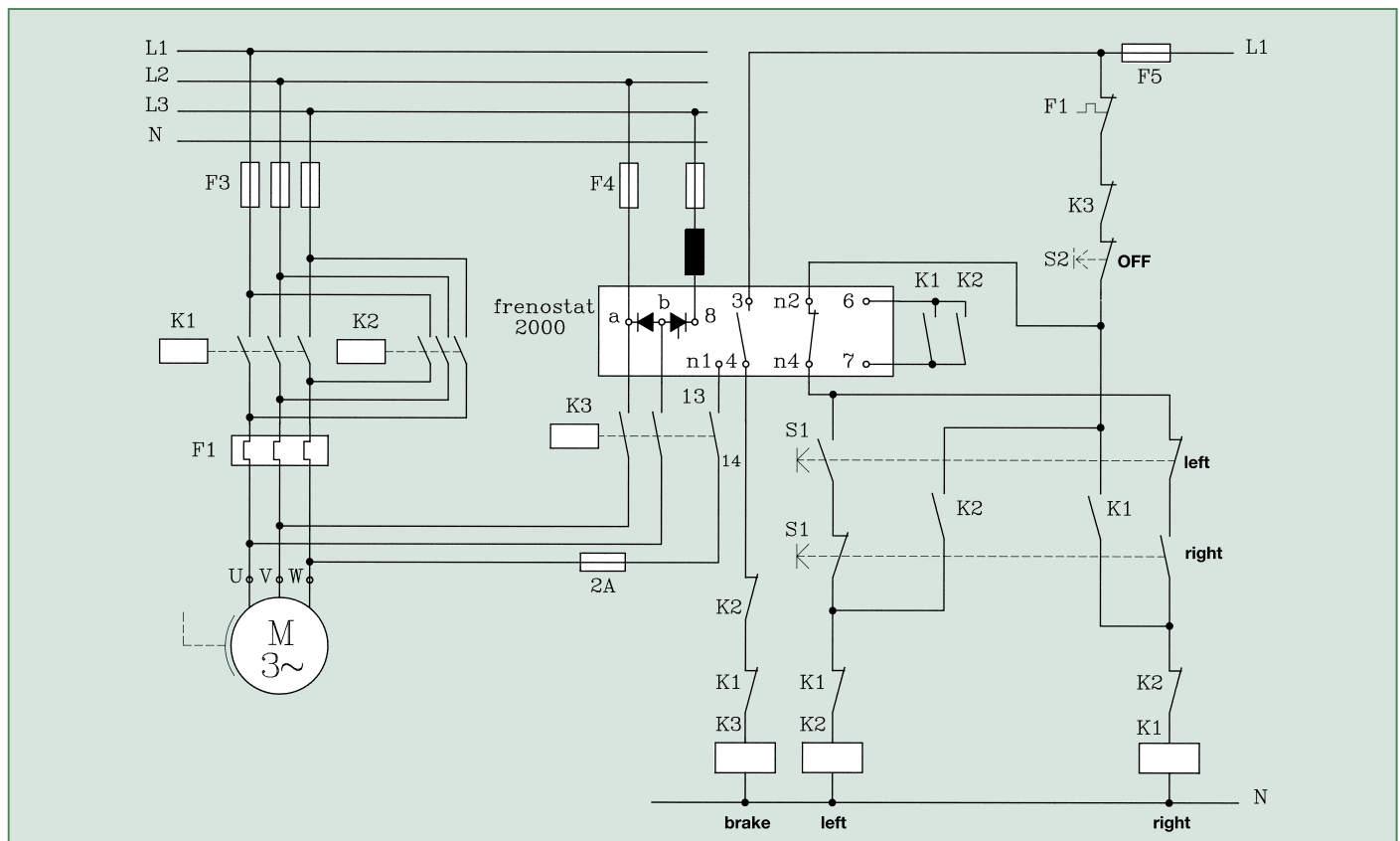

Circuit diagram 3

▼ Motor control for star-delta starting; braking with star connection (2 motor windings connected in series)

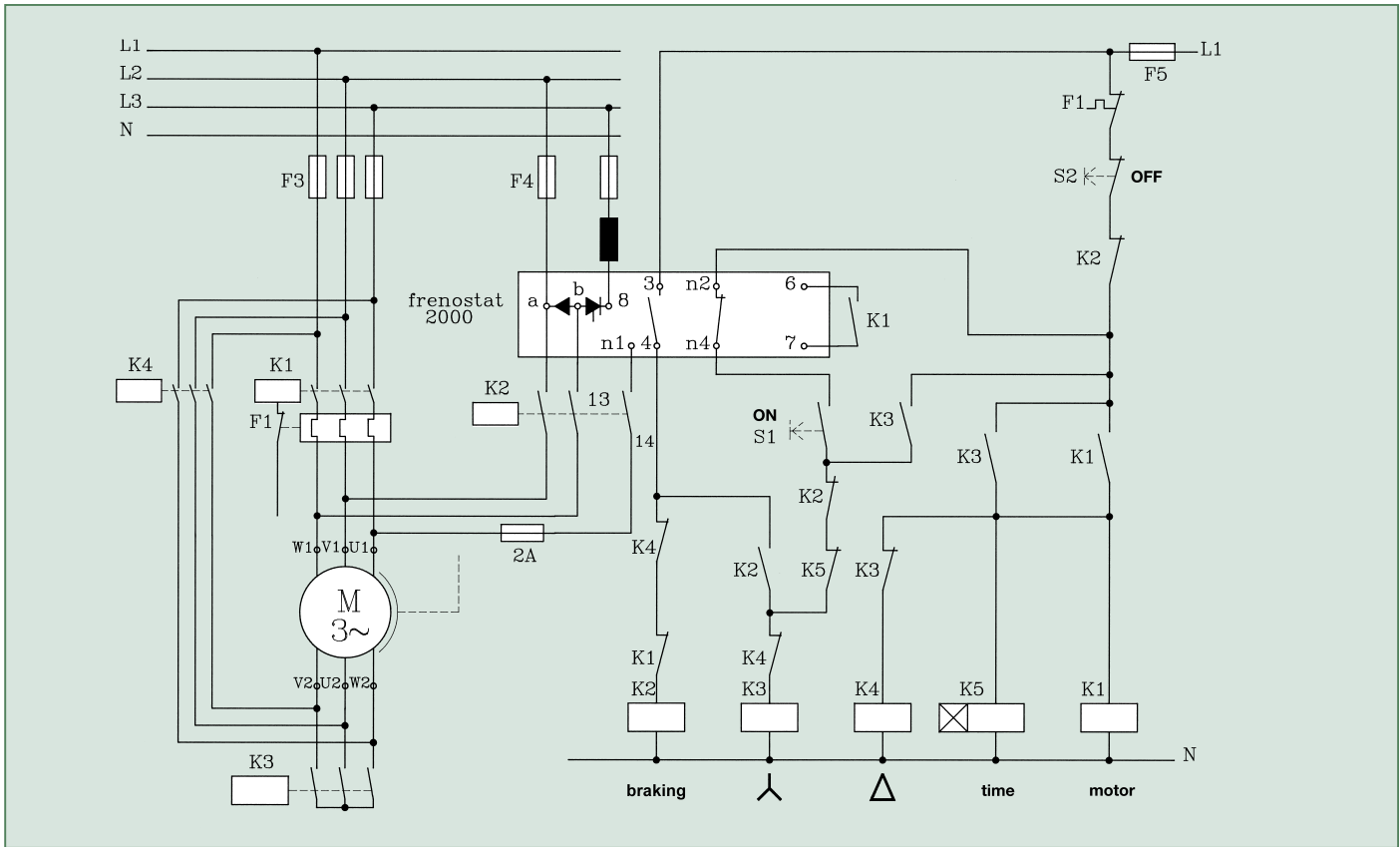

Circuit diagram 4

▼ Motor control for problem circuitry (Dahlander); braking acting on the motor winding at high speed

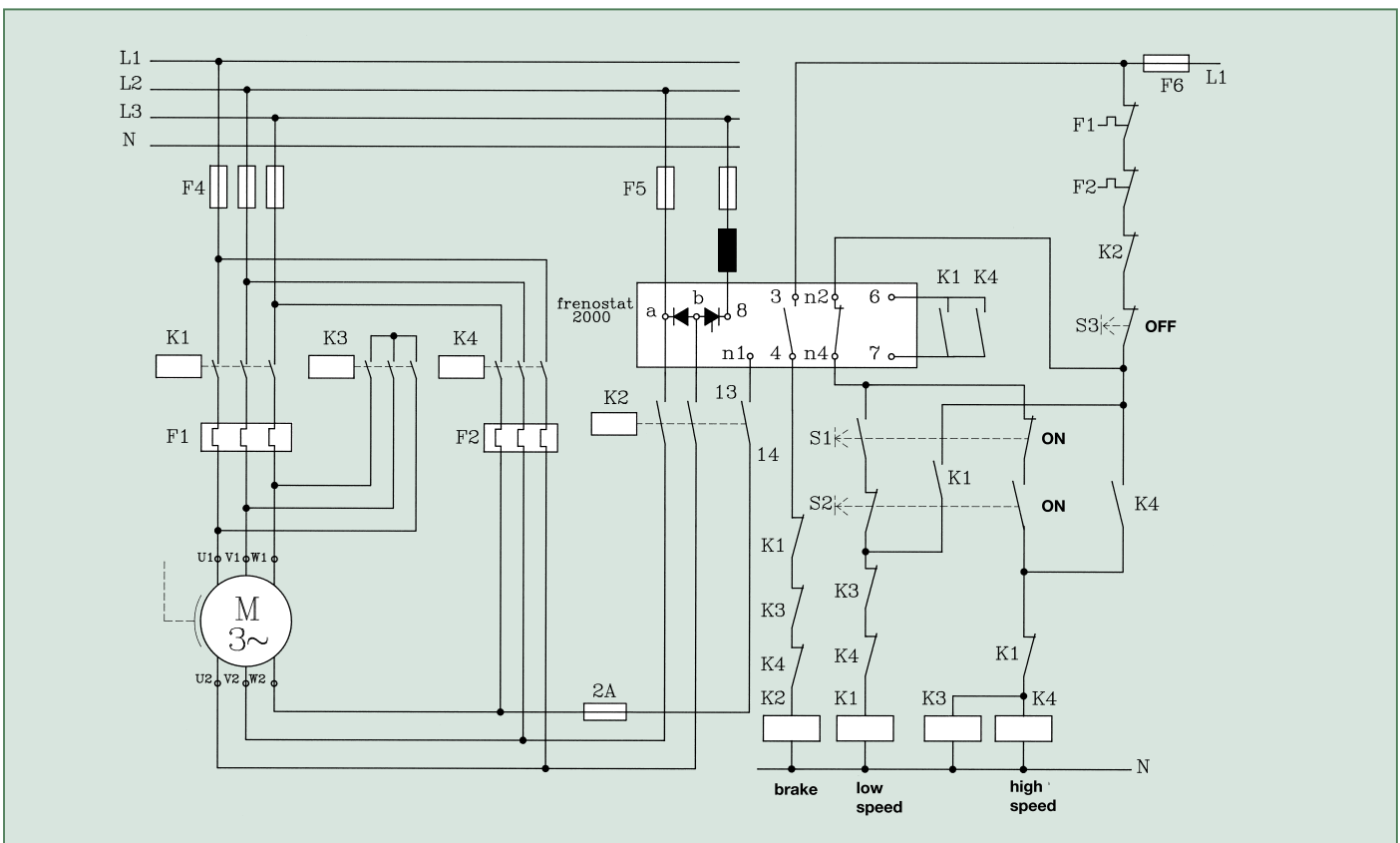

Circuit diagram 5

▼ Motor control for pole changing; braking acting on the motor winding at high speed

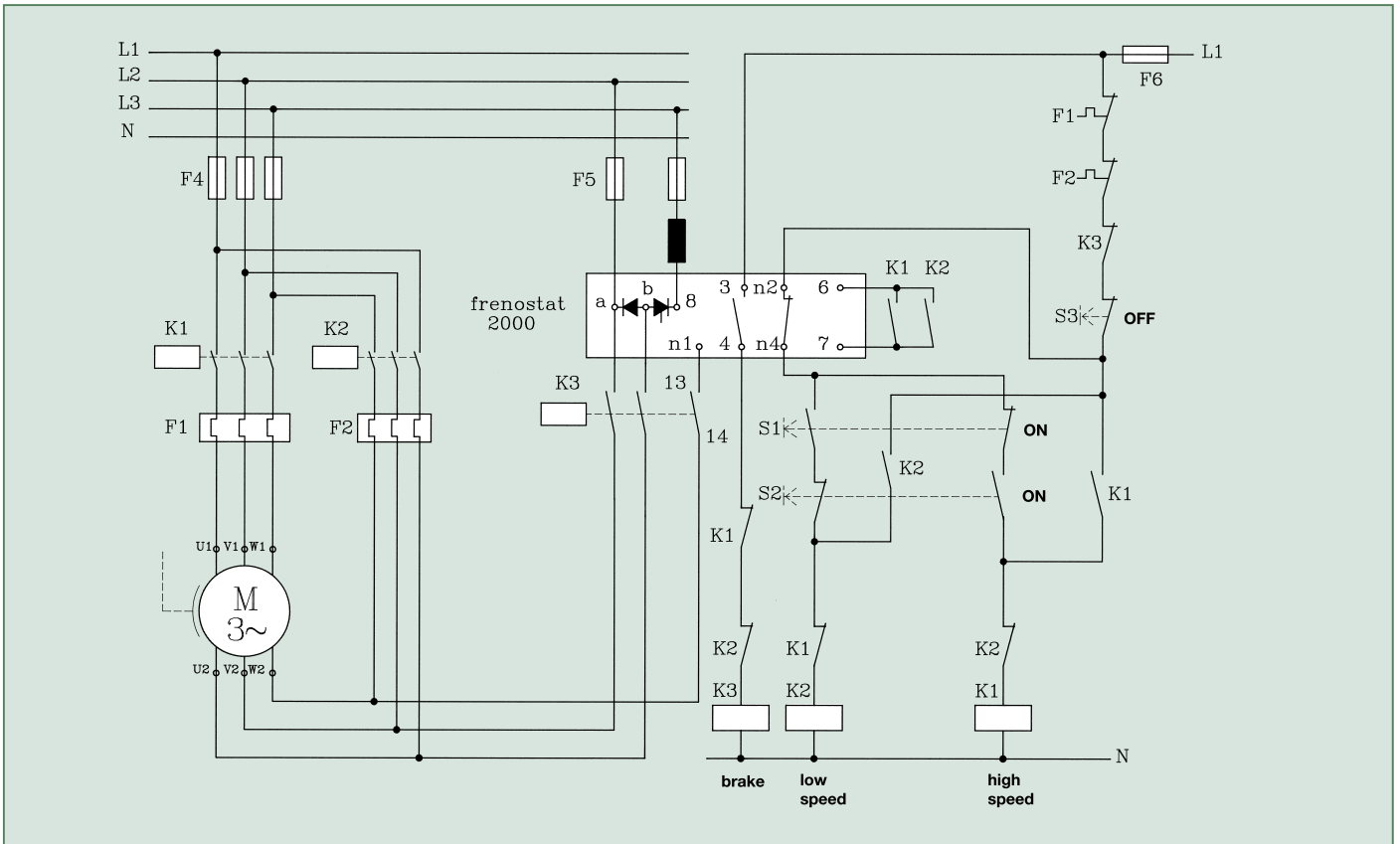

Circuit diagram 6

▼ 2-motor control; braking with series connection for motors >2 kW

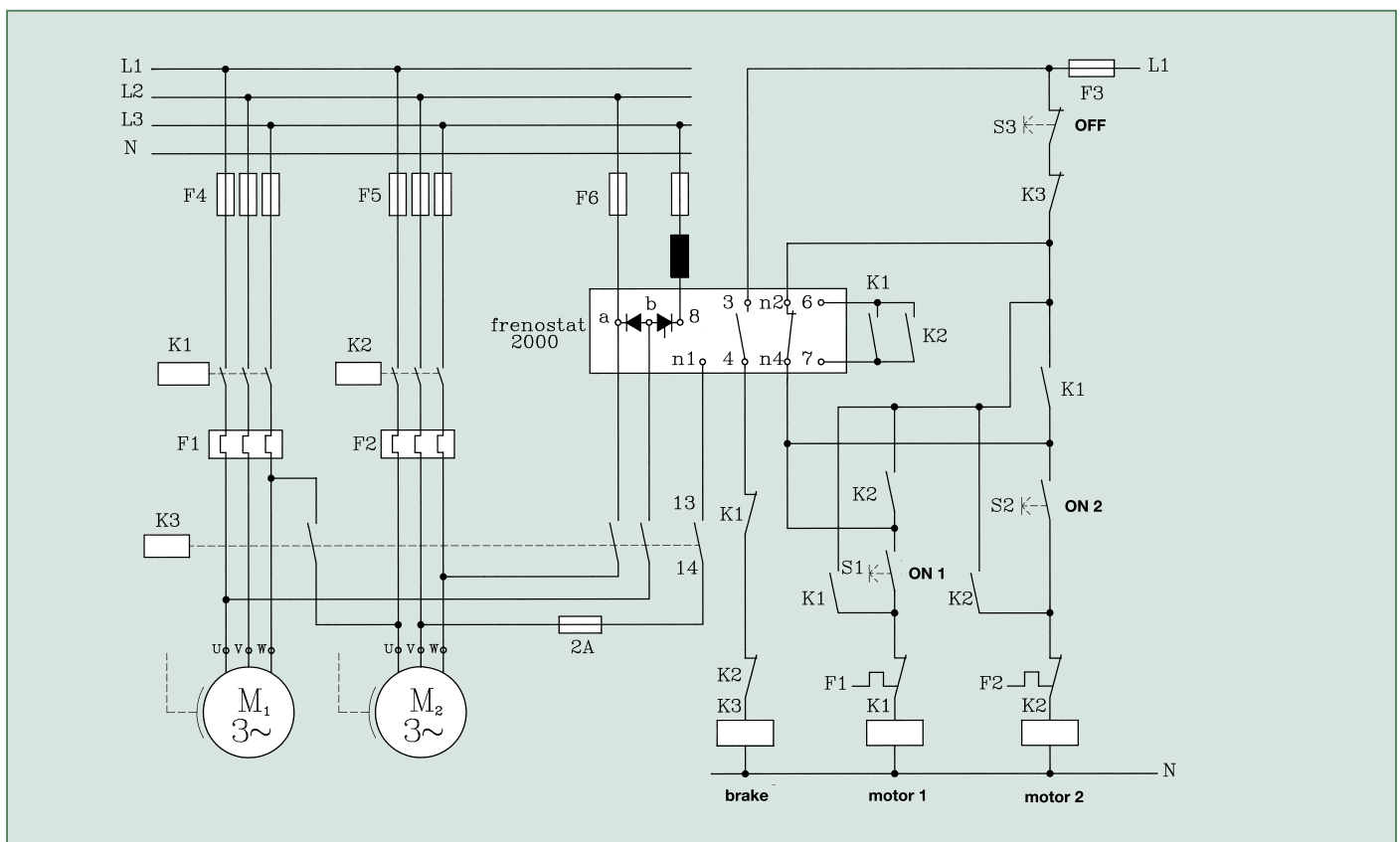

Circuit diagram 7

▼ 2-motor control; braking with parallel connection for motors <2 kW

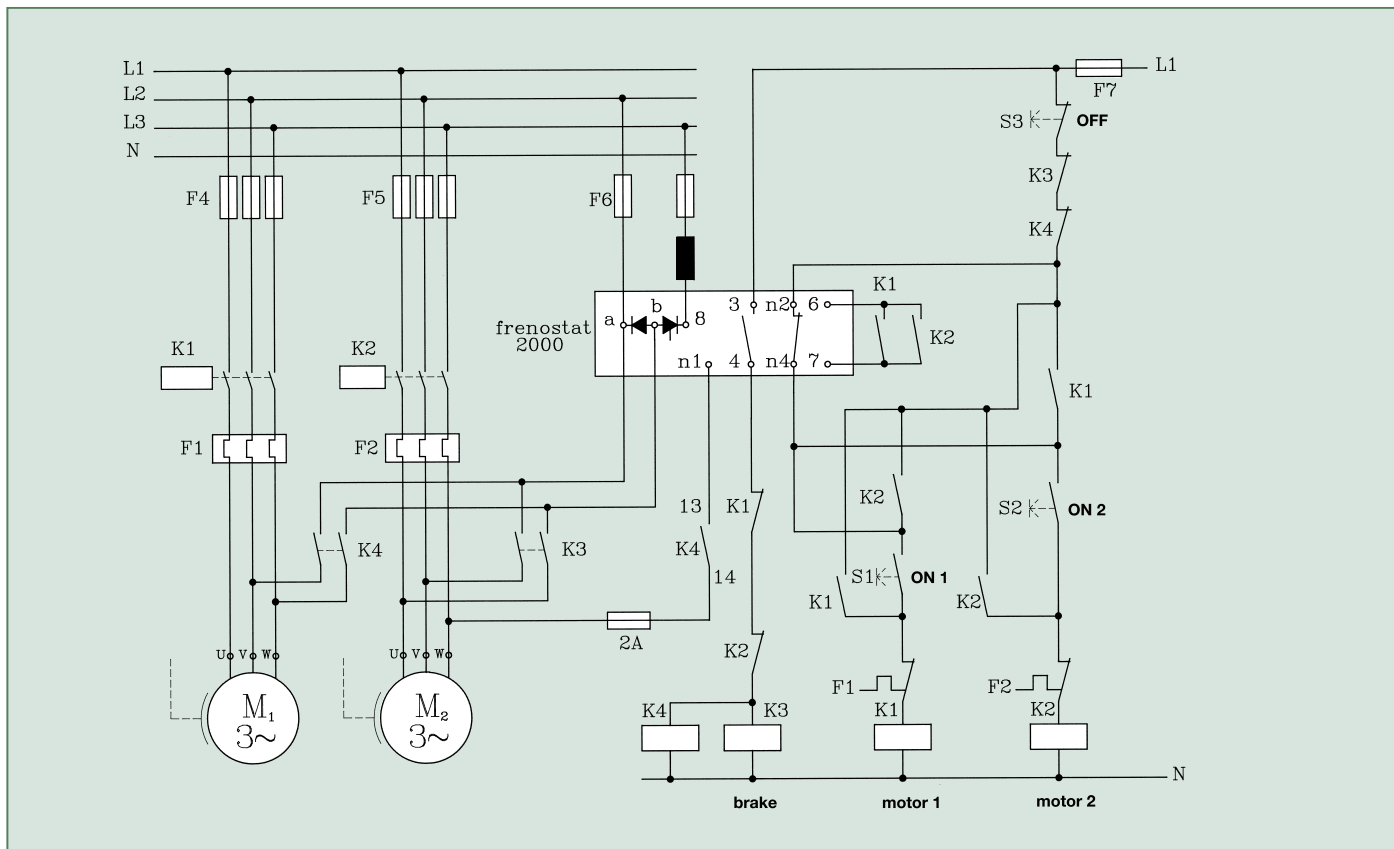

Accessory: line choke

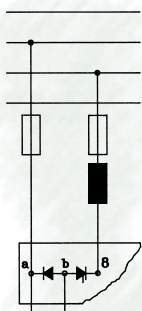

frenostat 2000 electronic brake units are power converter units that operate directly on the system using phase control.

Suitable interference suppression to increase noise immunity must be taken in electric cabinets in line with the EU's Directive on EMC, 89/336/EEC.

These suppressions must prevent not only interference susceptibility, but also actual interference of adjacent sensitive units, such as PLCs, frequency converters

or other microprocessor-based controllers that are connected to the same system. This necessitates the use of a line choke, which prevents system perturbation and protects the brake unit against resonant voltage peaks.

The line choke must be connected to line terminal 8 (L1) of the brake unit. The reactor is already integrated into Size 2 frenostat 2000 brake units (see page 10).

▼ Line choke selection table for frenomat and frenostat brake units

choke type (kVA)	Order number	For brake unit current (A)	Dimensions (h x w x d) (mm)	Weight (kg)
KS 0.05	00100005	up to 36	65 x 75 x 110	1.3
KS 0.075	00100075	up to 60	90 x 75 x 110	1.5
KS 0.25	00100250	up to 150	135 x 95 x 160	3.8
KS 0.5	00100500	up to 200	140 x 120 x 180	5.5
KS 1.0	00101000	up to 300	125 x 150 x 210	12.0
KS 1.6	00110160	up to 400	220 x 130 x 265	16.0
KS 2.0	00110200	up to 500	240 x 160 x 300	25.0
KS 3.0	00110300	up to 750	240 x 160 x 300	25.0
KS 4.0	00110400	up to 1500	240 x 235 x 300	33.0

Commissioning frenomat 2/frenostat 2000 electronic brake units

N.B.

- Electronic printed-circuit boards are live.
- Connect heat sinks to ground.
- Avoid using a long supply lead.
- Use an ohmmeter or multimeter.
Do not use a continuity tester or test lamp.

Activating without braking current

Remove the fuse from the motor. Set potentiometer "T" (time) to max. (turn clockwise as far as it will go) and potentiometer "I"

(current) to min. (turn counterclockwise as far as it will go).

Test interlocking

Motor contactor K 1	On	Off
Braking contactor K 2	Off	K 1 cannot be energized, On interlocked
Test interlock:	Energize K 2 by hand K 1 de-energizes	Energize K 1 by hand K 2 de-energizes

► Operating principle

Setting the braking current

Throw the motor fuse and turn potentiometer "T" (time) through a 1/4 turn. When the motor has reached its normal operating temperature, slowly turn potentiometer "I" (current) clockwise during braking and observe the current value on the LED bar display while doing so. 10 bars = 100% indication = rated current of the unit. During braking, LEDs "B" (braking) and "S" (standstill) light up. "B" indicates energizing of the output relays on terminals 3 and 4 and "S" monitors the rotation of the motor (On) until the standstill (Off).

LED "S" is off when braking is completed. The braking time set at potentiometer "T" (time) accumulates automatically. This can be set manually for post-braking that can last up to 20 seconds.

LED "O" (overheating) flashes if the heat sinks of the brake unit have become too hot due to too frequent braking. The motor cannot start again as long as this LED flashes.

frenostat 1000 and frenomat are not equipped with overheating protection.

Note With frenostat 1000 : connect a DC - ammeter to terminal T2.

With frenomat - 2 : connect a DC ammeter to terminal b.

International sales organization

Australia

Fraser, Hrones & Co.PTY.ltd.
NSW 2103 Mona Vale
Unit 36, 12-14 Waratah Street
Phone: 00612 / 99796333

Finland

OY HedTec AB
Postfach 110
201 Helsinki
Phone: 00358 / 968281

France

DOPAG S.a.r.L.
B.P. 64
26903 Valence
Phone: 0033 / 475419060

Great Britain

Stromag Ltd.
29 Wellingborough Road
Rushden, Northants
NN10 9YE
Phone: 0044 / 193350407

Italy

Transtecno S.R.L.
Via Caduti di Sabbiano, 11D/E
40011 Anzolo Emilia (Bo)
Phone: 00390 / 51731487

Netherlands

Bakker & Co.B.V.
Postbus 1235
3330 CE Zwijndrecht
Phone: 0031 / 786101666

Spain

Hermann-Otto Suderow S.L.
Apartado 135
48930 Las Arenas (Vizcaya)
Phone: 00349 / 44800018

Czech Republic

ELGO Electric s.r.o
Kourimska 103
28000 Kolin 1
Phone: 00420 / 32124489

The Hilger u. Kern / Dopag Group, which employs a workforce of more than 320 and has 6 international subsidiaries, is one of the world's largest manufacturers of metering and mixing systems, systems that deploy all processing concepts commonly in use for polymers and single-component media such as greases, oils and adhesives.

The Group has been developing and building machines, installations and one-off units tailored specifically to your requirements for more than 25 years.

Comprising 4 separate divisions specializing in Drive Technology, Metering Technology, Industrial Electronics and Spray Technology, Hilger u. Kern Industrietechnik, located in Mannheim, is one Germany's leading manufacturers of technically sophisticated, innovative and high-quality capital goods.



Hilger u. Kern GmbH
Germany



Drive Technology

Friction-locking and positive drive systems
Planetary gearing



Metering Technology

Mixing and metering systems for polymers and 1-component media



Industrial Electronics

Electronic softstarters and brake units, microcomputers, machine monitoring systems



Spray Technology

Spray system, material supply, customized systems



Dopag Headquarters
Switzerland

Dopag SCAN Aps
Denmark

Dopag UK Ltd.
England

Dopag S.A.R.L.
France

Dopag SDN. BHD
Malaysia

Dopag Sverige AB
Sweden



Hilger u. Kern Industrieelektronik

Hilger u. Kern GmbH · Käfertaler Straße 253 · 68167 Mannheim · DEUTSCHLAND

Phone: +49 (0)621 / 37 05 - 0 · Fax: +49 (0)621 / 37 05 - 2 00 · E-mail: industrieelektronik@hilger-kern.de · Home: www.hilger-kern.com