

















Product Sheet

Part Number: CKAXS 03 I



Family	CKA and MKA enclosures
Version	EMC version
Series	bulkhead mounting housings with single lever
Product type	with stainless steel lever
Quality mark	               
IP degree of protection	IP44 (EN 60529) degree of protection, IP66/67 degree of protection with CKR 65 kit or CKR 65 D kit.
Fixing centre distance	size "21.21"
Material	metal

The information and the dimensions contained are not binding and may be changed without prior notice.
The drawing's dimensions are in mm.

Notes

Enclosures with IP44 degree of protection.

To achieve the IP66/IP67 protection rating, a kit is available which includes a seal to be fitted under the insert fastening screw supplied with the kit (see example illustrated), instead of the screw with spring washer supplied with the insert.

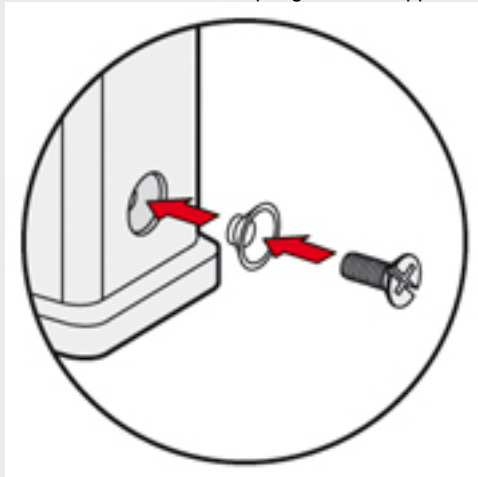

Note:

The CQ 12 inserts are already fitted with seal and screw, allowing IP66/IP67 protection rating to be achieved.