

GridVis®



2 tariffs



MID



Pulse output



Modbus





Areas of application

- Energy management
- Cost centre analysis
- Measured value transducer for PLC controls or building management systems (BMS)
- For energy billing purposes

Main features

- Communication: Modbus, M-Bus, S0 pulse outputs, EIB-KNX (for single-phase measurement)
- Direct measurement up to 63 A or via current transformer (.../1 A or .../5 A)
- 1 or 2 tariffs
- With MID approval
- Terminal cover can be lead-sealed
- 2 or 4-quadrant measurement
- Measured values: Effective energy, reactive energy, effective power, reactive power
- Precision class 1 for effective energy and class 2 for reactive energy

Applications

- Logging of active and reactive energy
- Effective pulses can be connected on a control system PLC, SCADA system or data logger via pulse outputs as a measured value transducer.
- Integrated interface makes available protocols such as M-Bus and Modbus RTU
- Measurements of 1 and 3-phase systems with a voltage of L-N 230 V AC / L-L 400 V AC
- Measurement of input currents via direct connection or via current transformer (.../1 A or .../5 A)
- DIN rail installation



Fig.: Sealed device protects against manipulations.

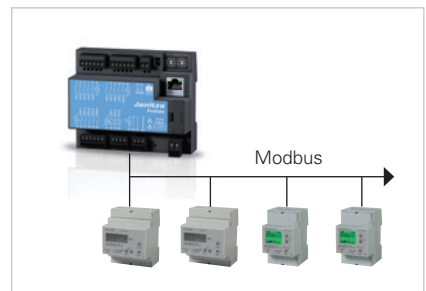

Fig.: Measured energy values are available via the integrated communication interface Modbus RTU.



Dimension diagrams and typical connection

All dimensions in mm

ECSEM88MID meter (Pulse output)

Dimension diagram

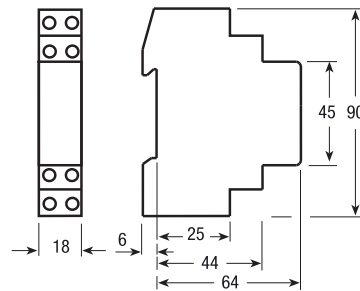

Circuit diagram

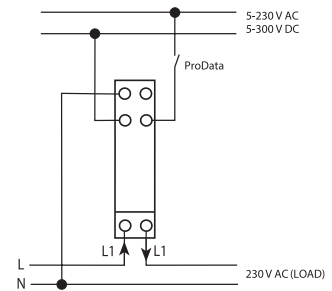

ECSEM212MID meter (Pulse output)

Dimension diagram

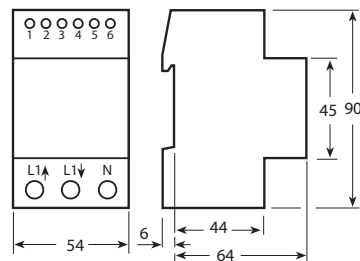

Circuit diagram

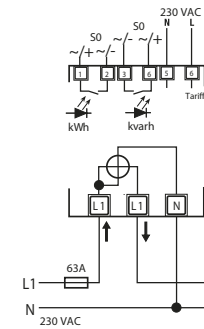

ECSEM214MID meter (Modbus)

Dimension diagram

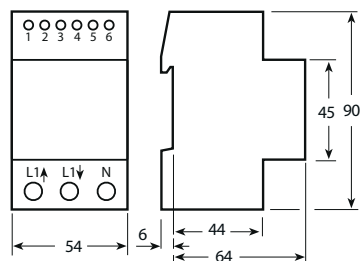

Circuit diagram

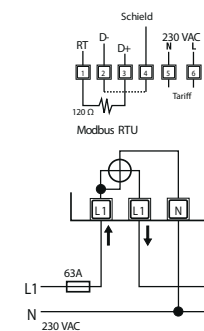

ECSEM216MID meter (M-Bus)

Dimension diagram

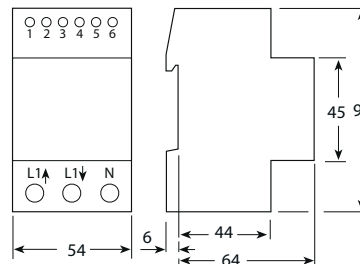

Circuit diagram

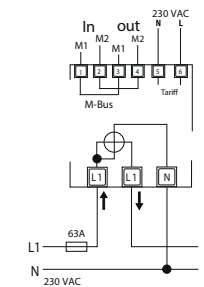

MID energy meter ECSEM series

ECSEM129MID meter (Pulse output, current transformer x/1 A)

Dimension diagram

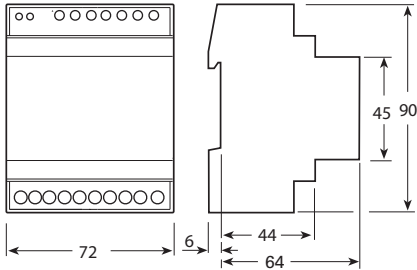

Circuit diagram

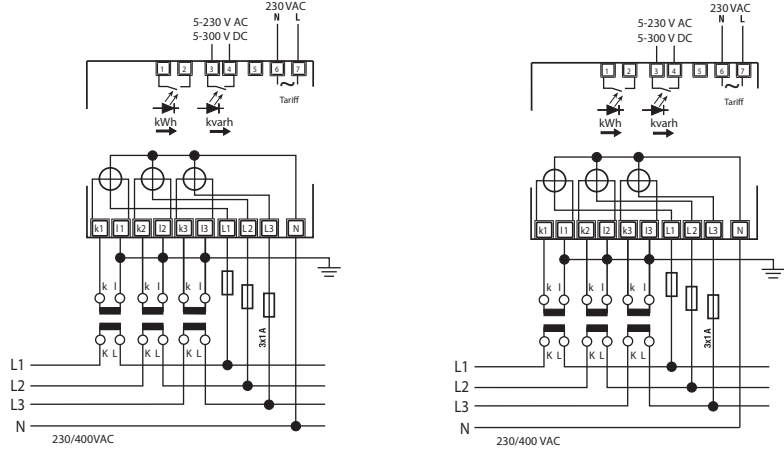

A neutral conductor at the energy meter is essential. Earthing the secondary winding of the external current transformer is mandatory by law in many countries. Please check the regional requirements (utility technical connection requirements) prior to installation.

ECSEM66MID meter (Pulse output, current transformer x/5 A)

Dimension diagram

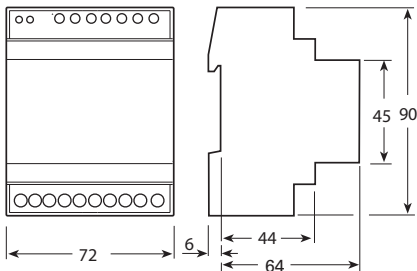

Circuit diagram

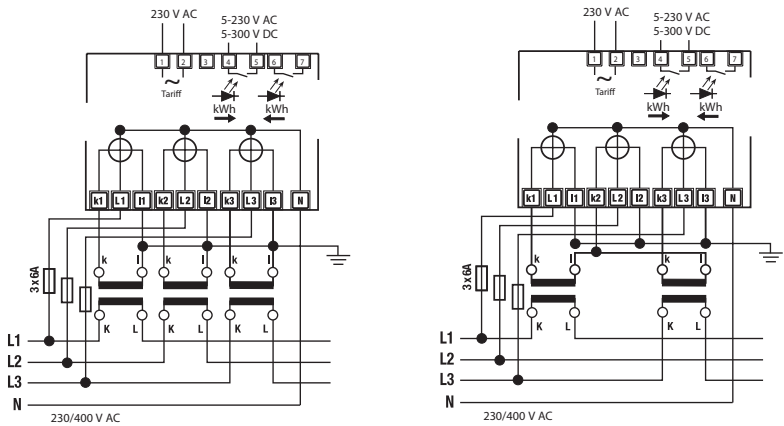

A neutral conductor at the energy meter is essential. Earthing the secondary winding of the external current transformer is mandatory by law in many countries. Please check the regional requirements (utility technical connection requirements) prior to installation.

ECSEM110MID meter (Pulse output, 63 A direct measurement)

Dimension diagram

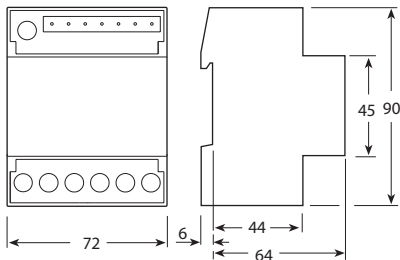

Circuit diagram

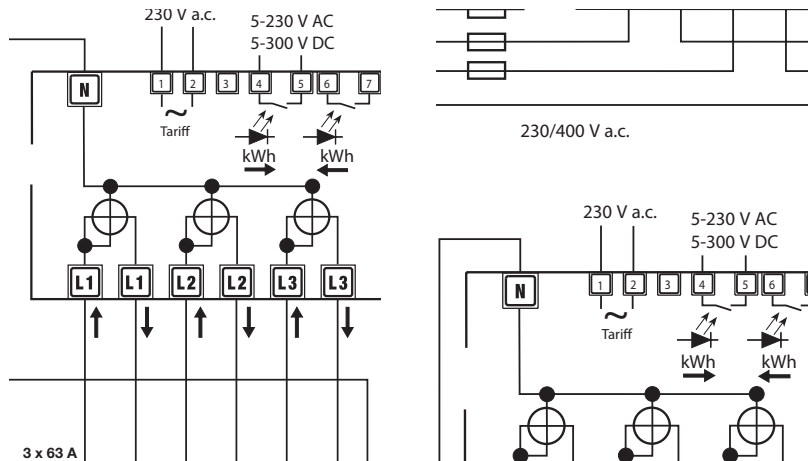

A neutral conductor at the energy meter is essential.



Device overview and technical data



Image similar

Single-phase energy meter

Three-phase energy meter (S0 pulse outputs)

Types	ECSEM88MID	ECSEM212MID	ECSEM214MID	ECSEM216MID	ECSEM129MID	ECSEM66MID	ECSEM110MID
	1 S0 pulse output	2 S0 pulse outputs	Modbus	M-Bus	2 S0 pulse outputs	2 S0 pulse outputs	2 S0 pulse outputs
	Pulse value 1,000 pulses/ kWh, Duration 90 ms	Pulse value 500 pulses/kWh/ kvarh, Duration 30...50 ms			Pulse value 100-10-1 pulses/ kWh/kvarh, depending on the CT Duration 30... 100 ms	Pulse value 100-10-1 pulses/ kWh/kvarh, depending on the CT Duration 30 ± 2 ms	Pulse value 500 pulses/kWh/ kvarh, Duration 30 ± 2 ms
Item number	14.01.335	14.01.341	14.01.336	14.01.337	14.01.338	14.01.339	14.01.340

Communication module for the expansion of the energy meter via IR interface**							
EIB-KNX*	•	•	•	•	-	-	-

* Item number: 14.01.412
Baud rate: 9,600 Baud; transferred variables: Wh, kvarh, V, A, Hz, cos phi, kW, kvar.

** The EIB-KNX communication module is equipped with an optical IR interface on the side. Through simple click-on installation it is possible to expand the energy meters ECSEM88MID, ECSEM119MID, ECSEM121MID and ECSEM123MID by an additional EIB-KNX interface.

Technical data							
Connection	32 A Direct measurement	63 A Direct measurement	63 A Direct measurement	63 A Direct measurement	... 1/A Current transformer	... 5/A Current transformer	63 A Direct measurement
Dimensions in mm (H x W x D)	90 x 18 x 70	90 x 54 x 70	90 x 54 x 70	90 x 54 x 70	90 x 72 x 70	90 x 72 x 70	90 x 72 x 70
Units width	1	3	3	3	4	4	4
Power consumption	8 VA	2.1 VA	2.1 VA	2.1 VA	2.1 VA	2.1 VA	2.1 VA
Max. burden at current connections (I _{Max})	0.9 VA	2.0 VA	2.0 VA	2.0 VA	0.5 VA per phase	0.5 VA per phase	2.0 VA per phase
Working temperature (°C)	-25 ... +55	-25 ... +55	-25 ... +55	-25 ... +55	-25 ... +55	-25 ... +55	-25 ... +55
Storage temperature (°C)	-25 ... +70	-25 ... +70	-25 ... +70	-25 ... +70	-25 ... +70	-25 ... +70	-25 ... +70
Protection type (front / terminals)	IP51 / IP20	IP51 / IP40	IP51 / IP40	IP51 / IP40	IP51 / IP20	IP51 / IP20	IP51 / IP20*3
Max. connectible wires cross sections (mm ²)	Measurement: 16	Measurement: 50 Tariff input: 1.5	Measurement: 50 Tariff input: 1.5	Measurement: 50 Tariff input: 1.5	Measurement: 4 Tariff input: 1.5	Measurement: 4 Tariff input: 1.5	Measurement: 35 Tariff input: 1.5
Supply voltage	Self-supplied	Self-supplied	Self-supplied	Self-supplied	Self-supplied	Self-supplied	Self-supplied
Measurement range							
Voltage range (V AC)	184 ... 276 V AC	92 ... 276 V AC	92 ... 276 V AC	92 ... 276 V AC	110 ... 276 V AC 190 ... 480 V AC	184 ... 276 V AC 319 ... 480 V AC	92 ... 276 V AC 160 ... 480 V AC
Current range (A)	0.02 ... 32	0.02 ... 80	0.02 ... 80	0.02 ... 80	0.001 ... 1.2	0.003 ... 6	0.015 ... 80
Frequency, Fundamental oscillation (Hz)*1	50	50	50	50	50	50	50
Measurement	1-phase	1-phase	1-phase	1-phase	3-phase (4 conductor)	3-phase (4 conductor)	3-phase (4 conductor)
Measured values							
Measuring accuracy Active energy	Class B	Class B	Class B	Class B	Class B	Class B	Class B
Measuring accuracy Reactive energy	Class 2	Class 2	Class 2	Class 2	Class 2	Class 2	Class 2
Tariffs	1	2	2	2	2	2	2
Voltage	L1, L2, L3	-	-	□*2	-	-	-
	L1-2, L2-3, L3-1	-	-	-	-	-	-
Current	L1, L2, L3	-	-	□*2	-	-	-
	N	-	-	-	-	-	-
Power factor	L1, L2, L3	-	-	□*2	-	-	-
	ΣL	-	-	-	-	-	-

□ Remote read-out *1 MID only 50 Hz *2 Only L1

Measured values								
Frequency		-	-	□	□	-	-	-
Active power	L1, L2, L3	●*2	●*2	●*2 □*2	●*2 □*2	-	-	-
	ΣL	-	-	-	-	-	-	-
Reactive power	L1, L2, L3	-	●*2	●*2 □*2	●*2 □*2	-	-	-
	ΣL	-	-	-	-	-	-	-
Apparent power	L1, L2, L3	-	-	□*2	□*2	-	-	-
	ΣL	-	-	-	-	-	-	-
Active energy (consumption)	L1, L2, L3, ΣL	●*2	●*2	●*2 □*2	●*2 □*2	●	●	●
	Tariffs 1 and 2	●*3	●*2	●*2 □*2	●*2 □*2	●	●	●
Active energy (delivery)	L1, L2, L3, ΣL	●*2	●*2	●*2 □*2	●*2 □*2	●	●	●
	Tariffs 1 and 2	●*3	●*2	●*2 □*2	●*2 □*2	●	●	●
Reactive energy (consumption)	L1, L2, L3, ΣL	-	●*2	●*2 □*2	●*2 □*2	-	-	-
	Tariffs 1 and 2	-	●*2	●*2 □*2	●*2 □*2	-	-	-
Reactive energy (delivery)	L1, L2, L3, ΣL	-	●*2	●*2 □*2	●*2 □*2	-	-	-
	Tariffs 1 and 2	-	●*2	●*2 □*2	●*2 □*2	-	-	-
Active energy (part. consumption)	ΣL	-	-	-	-	-	-	-
	Tariffs 1 and 2	-	-	-	-	-	-	-

● Display □ Remote read-out *2 Only L1 *3 Only tariff 1



Dimension diagrams and typical connection

All dimensions in mm

ECSEM155MID meter (Modbus, current transformer x/1 A)

ECSEM155MID circuit diagram (Modbus)

Dimension diagram

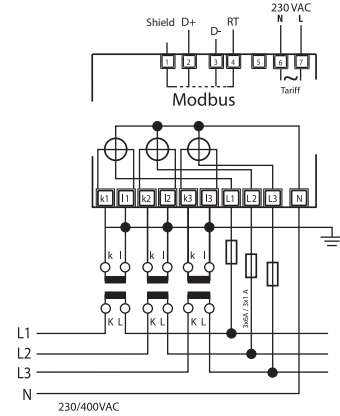
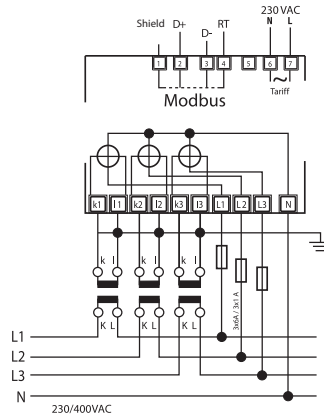
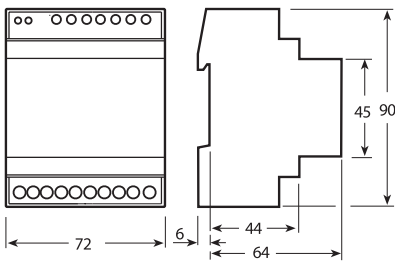

A neutral conductor at the energy meter is essential. Earthing the secondary winding of the external current transformer is mandatory by law in many countries. Please check the regional requirements (utility technical connection requirements) prior to installation.

ECSEM157MID meter (M-Bus, current transformer x/1 A)

ECSEM157MID circuit diagram (M-Bus)

Dimension diagram

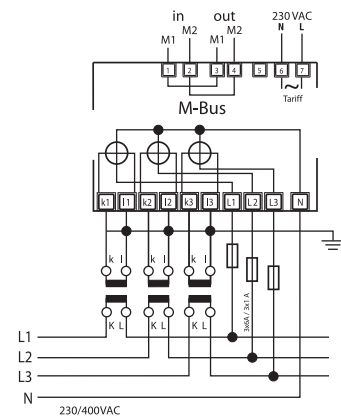
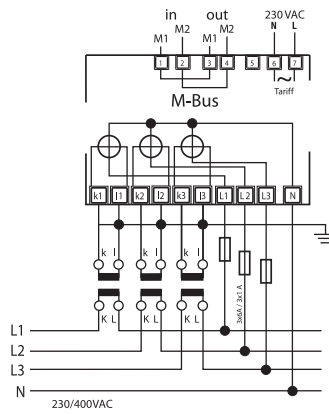
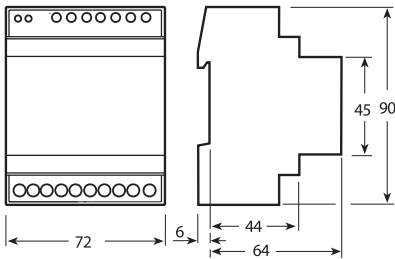

A neutral conductor at the energy meter is essential. Earthing the secondary winding of the external current transformer is mandatory by law in many countries. Please check the regional requirements (utility technical connection requirements) prior to installation.

MID energy meter ECSEM series

ECSEM68MID / ECSEM67MID meter group (current transformer x/5 A)

Dimension diagram

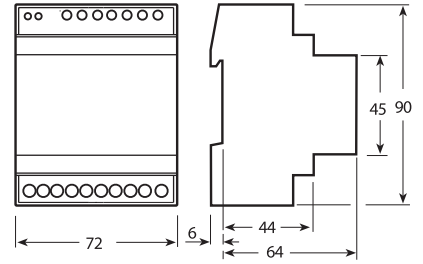

ECSEM68MID circuit diagram
(Modbus)

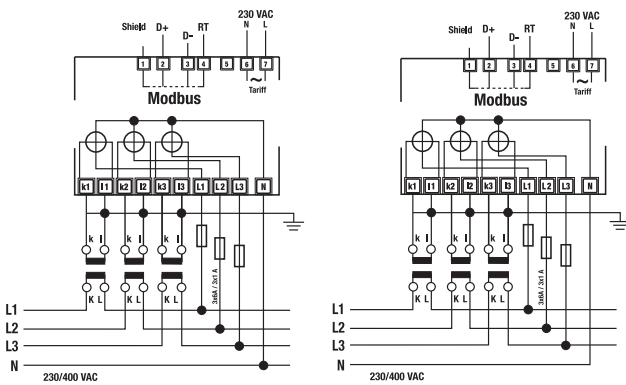

ECSEM67MID circuit diagram
(M-Bus)

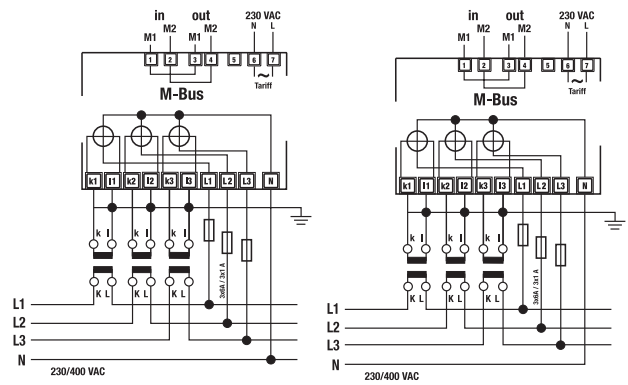

A neutral conductor at the energy meter is essential. Earthing the secondary winding of the external current transformer is mandatory by law in many countries. Please check the regional requirements (utility technical connection requirements) prior to installation.

ECSEM112MID / ECSEM114MID meter group (63 A direct measurement)

Dimension diagram

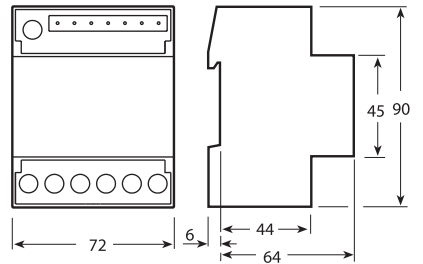

ECSEM112MID circuit diagram
(M-Bus)

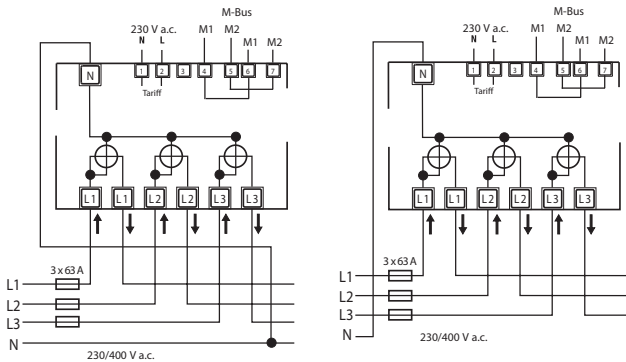

ECSEM114MID circuit diagram
(Modbus)

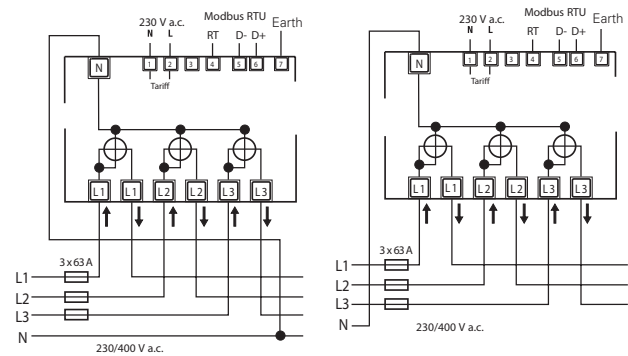

A neutral conductor at the energy meter is essential.



Device overview and technical data



Three-phase energy meter with integrated communications interface

Types*1	ECSEM155MID (Modbus)	ECSEM157MID (M-Bus)	ECSEM68MID (Modbus)	ECSEM67MID (M-Bus)	ECSEM76MID (Modbus)	ECSEM75MID (M-Bus)
Item number	14.01.323	14.01.325	14.01.313	14.01.317	14.01.315	14.01.319

*1 Please note: Due to the integrated interface, these energy meters are supplied without IR interface.

Technical data						
Connection	... 1/A Current transformer	... 1/A Current transformer	... 5/A Current transformer	... 5/A Current transformer	63 A Direct measurement	63 A Direct measurement
Device dimensions in mm (H x W x D)	90 x 72 x 70	90 x 72 x 70	90 x 72 x 70	90 x 72 x 70	90 x 72 x 70	90 x 72 x 70
Units width	4	4	4	4	4	4
Power consumption	2.1 VA	2.1 VA	2.1 VA	2.1 VA	2.1 VA	2.1 VA
Max. burden at current connections (I_{Max})	0.5 VA per phase	0.5 VA per phase	0.5 VA per phase	0.5 VA per phase	2.0 VA per phase	2.0 VA per phase
Working temperature (°C)	-25 ... +55	-25 ... +55	-25 ... +55	-25 ... +55	-25 ... +55	-25 ... +55
Storage temperature (°C)	-25 ... +70	-25 ... +70	-25 ... +70	-25 ... +70	-25 ... +70	-25 ... +70
Protection type (front / terminals)	IP51 / IP20	IP51 / IP20	IP51 / IP20	IP51 / IP20	IP51 / IP20	IP51 / IP20
Max. connectible wires cross sections (mm ²)	Measurement: 4 Tariff input: 1.5	Measurement: 4 Tariff input: 1.5	Measurement: 4 Tariff input: 1.5	Measurement: 4 Tariff input: 1.5	Measurement: 35 Tariff input: 1.5	Measurement: 35 Tariff input: 1.5
Supply voltage	Self-supplied	Self-supplied	Self-supplied	Self-supplied	Self-supplied	Self-supplied
Measurement range						
Voltage range (V AC)	110 ... 276 V AC 190 ... 480 V AC	110 ... 276 V AC 190 ... 480 V AC	110 ... 276 V AC 190 ... 480 V AC	110 ... 276 V AC 190 ... 480 V AC	92 ... 276 V AC 160 ... 480 V AC	92 ... 276 V AC 160 ... 480 V AC
Current range (A)	0.001 ... 1.2	0.001 ... 1.2	0.003 ... 6	0.003 ... 6	0.015 ... 63	0.015 ... 63
Frequency, fundamental oscillation (Hz)*2	50	50	50	50	45 ... 65	45 ... 65
Measurement	3-phase (4 conductor)	3-phase (4 conductor)	3-phase (4 conductor)	3-phase (4 conductor)	3-phase (4 conductor)	3-phase (4 conductor)
Measured values						
Measuring accuracy Active energy	Class B	Class B	Class B	Class B	Class B	Class B
Measuring accuracy Reactive power	Class 2	Class 2	Class 2	Class 2	Class 2	Class 2
Tariffs	2	2	2	2	2	2
Voltage	L1, L2, L3	□	□	□	□	□
	L1-2, L2-3, L3-1	□	□	□	□	□
Current	L1, L2, L3, N	□	□	□	□	□
	Power factor	L1, L2, L3, ΣL	□	□	□	□
Frequency		□	□	□	□	□
Active power	L1, L2, L3, ΣL	□	□	□	□	□
Reactive power	L1, L2, L3, ΣL	□	□	□	□	□
Apparent power	L1, L2, L3, ΣL	□	□	□	□	□

□ Remote read-out

*2 MID only 50 Hz

MID energy meter ECSEM series

Three-phase energy meter with integrated communications interface

Types*1	ECSEM155MID (Modbus)	ECSEM157MID (M-Bus)	ECSEM68MID (Modbus)	ECSEM67MID (M-Bus)	ECSEM76MID (Modbus)	ECSEM75MID (M-Bus)
Item number	14.01.323	14.01.325	14.01.313	14.01.317	14.01.315	14.01.319

*1 Please note: Due to the integrated interface, these energy meters are supplied without IR interface.

Measured values							
Active energy (consumption)	L1, L2, L3, ΣL	● □	● □	● □	● □	● □	● □
	Tariffs 1 and 2	● □	● □	● □	● □	● □	● □
Active energy (delivery)	L1, L2, L3, ΣL	● □	● □	● □	● □	● □	● □
	Tariffs 1 and 2	● □	● □	● □	● □	● □	● □
Reactive energy (consumption)	L1, L2, L3, ΣL	□	□	□	□	□	□
	Tariffs 1 and 2	□	□	□	□	□	□
Reactive energy (delivery)	L1, L2, L3, ΣL	□	□	□	□	□	□
	Tariffs 1 and 2	□	□	□	□	□	□
Active energy (part. consumption)	ΣL	-	□	-	□	-	□
	Tariffs 1 and 2	●	●	●	●	●	●

● Display □ Remote read-out

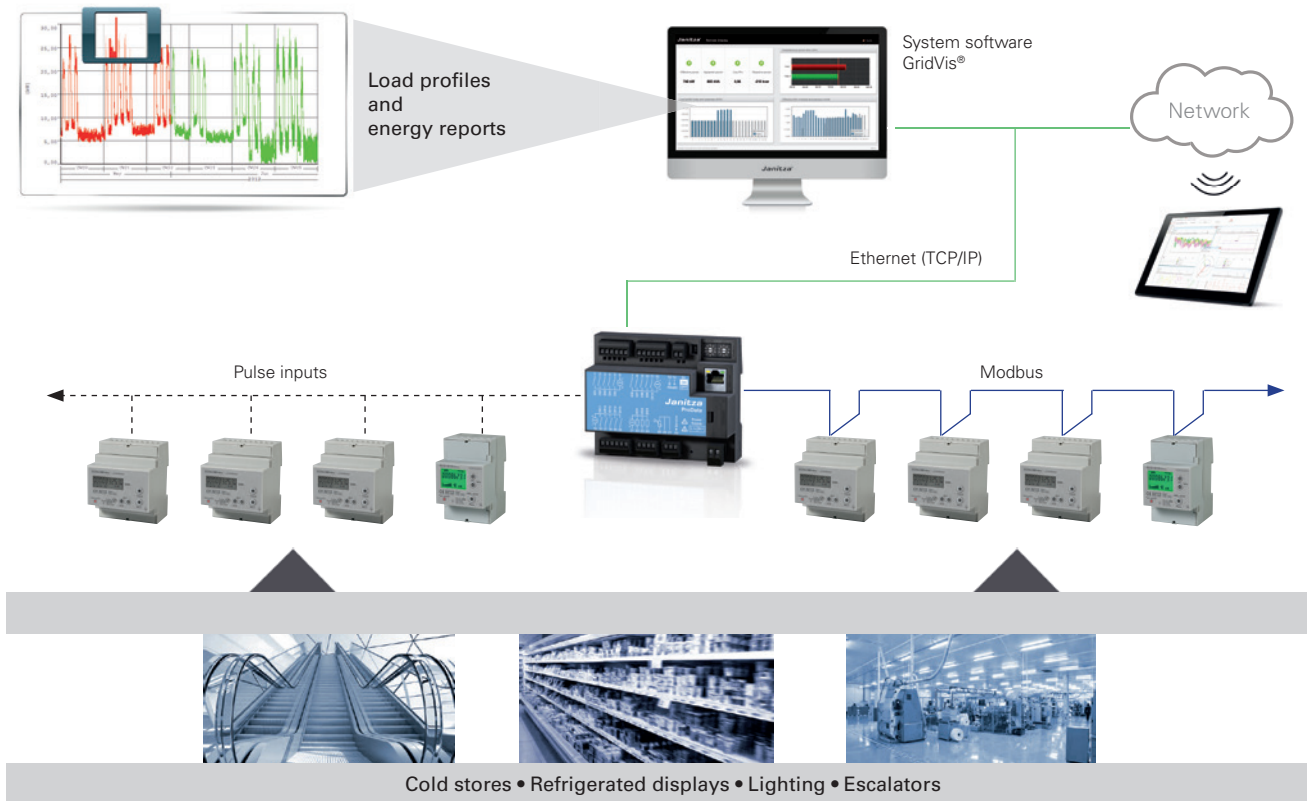

Fig.: Remote read-out with a superordinate PC via the Ethernet-Modbus gateway of the ProData® data logger

Janitza electronics GmbH
Vor dem Polstück 1
D-35633 Lahnau
Germany

Tel.: +49 6441 9642-0
Fax: +49 6441 9642-30
info@janitza.de
www.janitza.com

Sales partner

Version 01/2015 • Subject to technical alterations.