

SKINTOP® MSR-M

SKINTOP® MSR-M, brass cable gland with reducing seal insert, in areas where mechanical and chemical stability are critical

Info

SKINTOP® MSR-M 75 x 1.5 with innovative double lamella gasket for easier assembling of cables with large diameters. Now with IP69 approval! Proven to withstand the most demanding cleaning procedures for industrial machinery with high-pressure cleaners and hot water!

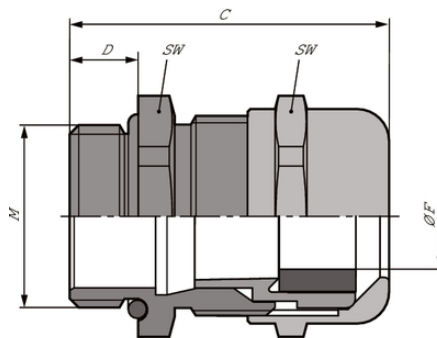

Variety of approval certifications



Temperature-resistant



Acid-resistant



Optimum strain relief



Mechanical resistance



Corrosion-resistant



Good chemical resistance

Application range

With reducing seal insert, to seal cables with smaller outer diameters.

Norm references / Approvals

UL File Nr. E79903

Last Update (03.07.2018)

©2018 Lapp Group - Technical changes reserved

Product Management www.lappkabel.de

You can find the current technical data in the corresponding data sheet.

PN 0456 / 02_03.16

SKINTOP® MSR-M

Product Make-up

Metric connection thread acc. to DIN EN 60423
Basis for technical information DIN IEC 62444

Note

Counter nut to be used: SKINDICHT® SM-M
Refer to SKINTOP® metric accessories for suitable accessories

Technical Data

Classification ETIM 5:	ETIM 5.0 Class-ID: EC000441 ETIM 5.0 Class-Description: Cable screw gland
Classification ETIM 6:	ETIM 6.0 Class-ID: EC000441 ETIM 6.0 Class-Description: Cable screw gland
Caution:	Refer to Appendix T21 for the installation dimensions and torques
Certifications:	IP 69 approval from size M75 x 1.5 pending. UL, CSA, DNV and VDE approval for sizes M90 x 2 to M110 x 2 pending.
Material:	Body: nickel-plated brass Insert: polyamide Sealing: CR O-ring: NBR
Protection rating:	IP 68 - 10 bar IP 69 (M12 - M63)
Temperature range:	dynamic -25°C up to + 100°C Fixed: -40°C to +100°C

Note

Photographs and graphics are not to scale and do not represent detailed images of the respective products.
Prices are net prices without VAT and surcharges. Sale to business customers only.

SKINTOP® MSR-M

Article number	Article designation / size	Clamping range ØF (mm)	SW wrench size mm	Overall length, C (mm)	Thread length, D (mm)
SKINTOP® MSR-M					
53112100	M 12 x 1,5	2 - 5	16	26.5	6.5
53112110	M 16 x 1,5	2 - 7	20	33.0	7
53112120	M 20 x 1,5	5 - 10	24	37.0	8.5
53112130	M 25 x 1,5	6 - 13	29	38.5	8
53112140	M 32 x 1,5	7 - 15	36	45.5	9
53112150	40 x 1,5	15 - 23	45	48.0	9
53112160	50 x 1,5	22 - 29	54	55.5	10
53112170	M 63 x 1,5	28 - 39	67	61.3	15
53112511	M 75 x 1,5	53 - 63	95	105.0	15
53112515	M 110 x 2	76 - 88	135	154.0	25

Last Update (03.07.2018)

©2018 Lapp Group - Technical changes reserved

Product Management www.lappkabel.deYou can find the current technical data in the corresponding data sheet.
PN 0456 / 02_03.16