



Bend

BU 90°

- 1
- 2
- 3
- 4
- 5
- 6
- 7
- 8
- 9
- 10
- 11
- 12
- 13
- 14
- 15
- 16
- 17
- 18



Description

Pressed and seam welded bend.

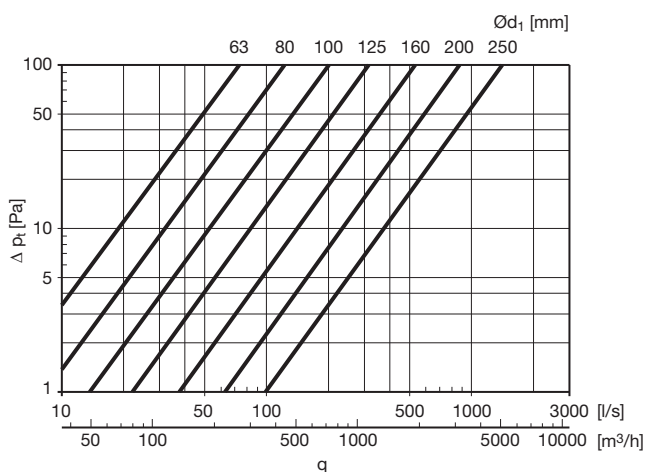

Dimensions

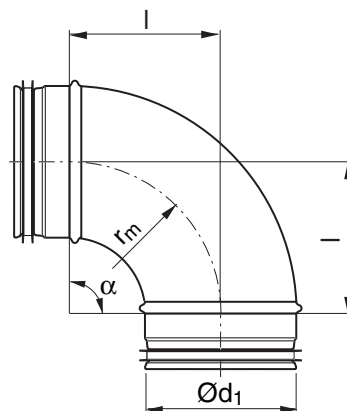

$$r_m \approx 1 \cdot d_1$$

$\text{Ø}d_1$ nom	l mm	m kg
63	110	0,20
80	105	0,26
100	100	0,31
112	120	0,39
125	125	0,48
140	135	0,66
150	150	0,66
160	160	0,74
180	180	1,02
200	200	1,12
224	225	1,33
250	250	1,77

Ordering example

