



Product range >> Current transformers for industry >> Wound current transformer (WSK)

**art. nr.: 31166**

**WSK 40N 40/5A 10VA Cl.1**



### Electrical Attributes:

|                    |       |
|--------------------|-------|
| Primary current:   | 40 A  |
| Secondary current: | 5 A   |
| Burden:            | 10 VA |
| Class:             | 1     |

### Dimensions:

|         |        |
|---------|--------|
| Width:  | 71 mm  |
| Height: | 107 mm |
| Depth:  | 55 mm  |

### Technical details:

Therm. nominal continuous current  $I_{cth}$ :  $1,0 \times I_N$   
Therm. nominal short-time current  $I_{th}$ :  $50 \times I_N$ , 1 sec.  
Max. operating voltage  $U_m$ : 0.72 kV  
Isolation test voltage: 3 kV,  $U_{eff}$ , 50 Hz, 1 min.  
Nominal rated frequency: 50 Hz  
Isolation class: E

### Further information:

|   |   |
|---|---|
| Over-current limiting factor:   | See rating plate                            |
| Working temperature range:  | $-5^\circ\text{C} < T < +40^\circ\text{C}$  |
| Storage temperature range:  | $-25^\circ\text{C} < T < +40^\circ\text{C}$ |
| Unbreakable plastic housing made of black polycarbonate:                | Flame resistant, ultrasonically welded      |
| Nickel-plated secondary terminals with plus-minus nickel-plated screws: | M5x10mm                                     |
| Secondary caps:   | integrated                                  |
| Package quantity:   | 1 pcs.                                      |
| Custom tariff number:   | 85043129                                    |



**Dimensions:**

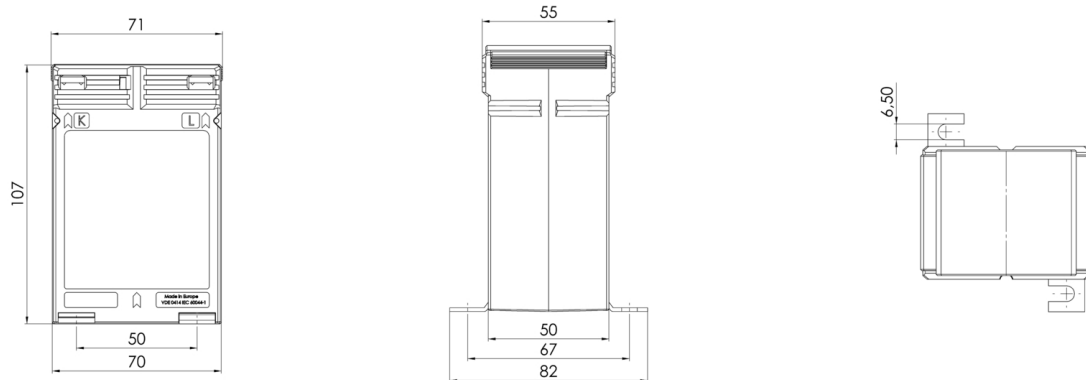

**Contact:**

MBS AG  
Sulzbach Messwandler  
Eisbachstraße 51  
D-74429 Sulzbach-Laufen

Tel.: +49 7976 9851-0  
Fax: +49 7976 9851-90  
orders@mbs-ag.com

