



**Contactor, 18,5kW/400V, DC operated**

**Part no.**

**DILM38-10(RDC24)**

**Article no.**

**112442**



**Program**

Product range			Contactors
Application			Contactors for Motors
Subrange			Contactors up to 170 A, 3 pole
Connection technique			Screw terminals
Pole			3 pole
Rated operational current			
AC-3			
380 V 400 V	$I_e$	A	38
AC-1			
Conventional free air thermal current, 3 pole, 50 - 60 Hz			
Open			
at 60 °C	$I_{th} = I_e$	A	40
Max. rating for three-phase motors, 50 - 60 Hz			
AC-3			
220 V 230 V	P	kW	11
380 V 400 V	P	kW	18.5
660 V 690 V	P	kW	21
AC-4			
220 V 230 V	P	kW	4
380 V 400 V	P	kW	7
660 V 690 V	P	kW	10
Contacts			
N/O = Normally open			1 N/O
Contact sequence			
<b>Instructions</b>			Contacts to EN 50012. integrated suppressor circuit in actuating electronics
Can be combined with auxiliary contact			DILM32-XHI.. DILA-XHI(V).. DILM32-XHI11-S
Voltage AC/DC			DC operation

**Approbationen**

Product Standards  
UL File No.  
UL CCN  
CSA File No.  
CSA Class No.  
NA Certification  
Specially designed for NA

IEC/EN 60947-4-1; UL 508; CSA-C22.2 No. 14-05; CE marking  
E29096  
NLDX  
012528  
2411-03, 3211-04  
UL Listed, CSA certified  
No

**General**

Standards			IEC/EN 60947, VDE 0660, UL, CSA
Lifespan, mechanical			
AC operated	Operations	$\times 10^6$	10
DC operated	Operations	$\times 10^6$	10
Operating frequency, mechanical			
AC operated	Operations/h		5000
DC operated	Operations/h		5000

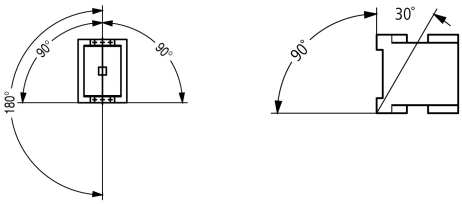
Climatic proofing			Damp heat, constant to IEC 60068-2-78 Damp heat, cyclic to IEC 60068-2-30
Ambient temperature		°C	
Open		°C	- 25 - 60
Enclosed		°C	- 25 - 40
Storage		°C	- 40 - 80
Mounting position, AC- and DC operated			
Mechanical shock resistance (IEC/EN 60068-2-27)			
Half-sinusoidal shock, 10 ms			
Main contacts			
N/O contact		g	10
Auxiliary contacts			
N/O contact		g	7
N/C contact		g	5
Mechanical shock resistance (IEC/EN 60068-2-27) when tabletop-mounted			
Half-sinusoidal shock, 10 ms			
Main contacts			
N/O contact		g	6.9
Auxiliary contacts			
N/O contact		g	5.3
N/C contact		g	3.5
Protection type			IP00
Protection against direct contact when actuated from front (EN 90274)			Finger- and back-of-hand proof
Weight			
AC operated		kg	0.42
DC operated		kg	0.48
Terminal capacity main cable			
Solid		mm <sup>2</sup>	1 x (0.75 - 16) 2 x (0.75 - 10)
Flexible with ferrule		mm <sup>2</sup>	1 x (0.75 - 16) 2 x (0.75 - 10)
Stranded		mm <sup>2</sup>	1 x 16
Solid or stranded		AWG	18 - 6
Main cable connection screw/bolt			M5
Tightening torque		Nm	3.2
Terminal capacity control circuit cables			
Solid		mm <sup>2</sup>	1 x (0.75 - 4) 2 x (0.75 - 4)
Flexible with ferrule		mm <sup>2</sup>	1 x (0.75 - 1.5) 2 x (0.75 - 1.5)
Solid or stranded		AWG	18 - 14
Control circuit cable connection screw/bolt			M3.5
Tightening torque		Nm	1.2
Tool			
Main cable			
Pozidriv screwdriver		Size	2
Standard screwdriver		mm	0.8 x 5.5 1 x 6
Control circuit cables			
Pozidriv screwdriver		Size	2
Standard screwdriver		mm	0.8 x 5.5 1 x 6
Terminal capacity control circuit cables			

Solid		mm <sup>2</sup>	1 x (0.75 - 2.5) 2 x (0.75 - 2.5)
Flexible		mm <sup>2</sup>	1 x (0.75 - 2.5) 2 x (0.75 - 2.5)
Flexible with ferrule		mm <sup>2</sup>	1 x (0.75 - 1.5) 2 x (0.75 - 1.5)
Solid or stranded		AWG	18 - 14
Tool			
Stripping length		mm	10
Screwdriver blade width		mm	3.5

### Main conducting paths

Rated impulse withstand voltage	$U_{imp}$	V AC	8000
Overvoltage category/pollution degree			III/3
Rated insulation voltage	$U_i$	V AC	690
Rated operational voltage	$U_e$	V AC	690
Safe isolation to VDE 0106 Part 101 and Part 101/A1			
between coil and contacts		V AC	440
between the contacts		V AC	440
Making capacity (p.f. to IEC/EN 60947)			
	$U_p$ to 690 V	A	384
Breaking capacity			
220/230 V		A	320
380/400 V		A	320
500 V		A	320
660/690 V		A	180
Short-circuit rating			
Short-circuit protection maximum fuse			
Type "2" coordination			
400 V	gG/gL 500 V	A	63
690 V	gG/gL 690 V	A	35
Type "1" coordination			
400 V	gG/gL 500 V	A	125
690 V	gG/gL 690 V	A	63

### AC

AC-1 duty			
Conventional free air thermal current, 3 pole, 50 - 60 Hz			
Open			
at 40 °C	$I_{th} = I_e$	A	45
at 50 °C	$I_{th} = I_e$	A	43
at 55 °C	$I_{th} = I_e$	A	42
at 60 °C	$I_{th} = I_e$	A	40
enclosed	$I_{th}$	A	36
Conventional free air thermal current, 1 pole			
open	$I_{th}$	A	100
enclosed	$I_{th}$	A	90
AC-3 duty			
Rated operational current AC-3 open, 50 - 60 Hz, 3 pole	$I_e$		
220/230 V	$I_e$	A	38
240 V	$I_e$	A	38
380/400 V	$I_e$	A	38
415 V	$I_e$	A	38
440V	$I_e$	A	38
500 V	$I_e$	A	38
660/690 V	$I_e$	A	22.5
Motor rating	P	kWh	

220/230 V	P	kW	11
240V	P	kW	12
380/400 V	P	kW	18.5
415 V	P	kW	20
440 V	P	kW	21
500 V	P	kW	24
660/690 V	P	kW	21
<b>AC-4 duty</b>			
Rated operational current AC-4 open, 50 - 60 Hz, 3 pole			
220/230 V	$I_e$	A	15
240 V	$I_e$	A	15
380/400 V	$I_e$	A	15
415 V	$I_e$	A	15
440 V	$I_e$	A	15
500 V	$I_e$	A	15
660/690 V	$I_e$	A	12
<b>Motor rating</b>			
220/230 V	P	kWh	
220/230 V	P	kW	4
240 V	P	kW	4.5
380/400 V	P	kW	7
415 V	P	kW	7.5
440 V	P	kW	8
500 V	P	kW	9
660/690 V	P	kW	10

## DC

Rated operational current, open			
<b>DC-1 operation</b>			
60 V	$I_e$	A	40
110 V	$I_e$	A	40
220 V	$I_e$	A	40
440 V	$I_e$	A	2.9
<b>DC-3 operation</b>			
60 V	$I_e$	A	40
110 V	$I_e$	A	40
220 V	$I_e$	A	25
440 V	$I_e$	A	0.6
<b>DC-5 operation</b>			
60 V	$I_e$	A	40
110 V	$I_e$	A	40
220 V	$I_e$	A	10
440 V	$I_e$	A	0.6

## Current heat loss (3 pole)

Current heat loss at $I_{th}$		W	12.1
Current heat loss at $I_e$ to AC-3/400 V		W	6.1
Impedance per pole		m $\Omega$	2

## Magnet systems

Voltage tolerance			
AC operated	Pick-up	$x U_c$	0.8 - 1.1
Drop-out voltage AC operated	Drop-out	$x U_c$	0.3 - 0.6
Notes			RDC 24 ( $U_{min}$ 24 V DC/ $U_{max}$ 27 V DC) Example: $U_c = 0.7 \times U_{min} - 1.2 \times U_{max} / U_c = 0.7 \times 24 V - 1.2 \times 27 V DC$
DC operated	Pick-up	$x U_c$	0.7 - 1.2
Notes			at least smoothed two-phase bridge rectifier or three-phase rectifier
DC operated	Drop-out	$x U_c$	0.15 - 0.6

Power consumption of the coil in a cold state and $1.0 \times U_c$			
50 Hz	Pick-up	VA	52
50 Hz	Sealing	VA	7.1
50 Hz	Sealing	W	2.1
60 Hz	Pick-up	VA	67
60 Hz	Sealing	VA	8.7
60 Hz	Sealing	W	2.6
50/60 Hz	Pick-up	VA	62 58
50/60 Hz	Sealing	VA	9.1 6.5
50/60 Hz	Sealing	W	2.5 2
DC operated	Pick-up	W	12
DC operated	Sealing	W	0.5
Duty factor		% DF	100
Switching times at 100 % $U_c$ (approximate values)			
Main contacts			
AC operated			
	Closing delay	ms	16 - 22
	Opening delay	ms	8 - 14
DC operated			
	Closing delay	ms	47
	Opening delay	ms	30
	Arcing time	ms	10
Lifespan, mechanical; Coil 50/60 Hz	at 50 Hz		Mechanical lifespan at 50 Hz approx. 30% lower than under "Technical data, general"

### Electromagnetic compatibility (EMC)

Emitted interference			to EN 60947-1
Interference immunity			to EN 60947-1

### Technical data according to ETIM 4.0

Number of main contacts as N/Os			3
Rated operation current $I_e$ at AC-1, 400 V			45
Connection type main circuit			Screw connection
Rated control voltage $U_s$ at AC 60HZ		V	0
Number of auxiliary contacts as N/Os			1
Rated control voltage $U_s$ at AC 50HZ		V	0
Number of auxiliary contacts as N/Cs			0
Suitable for rail-mounting			No
Rated control voltage $U_s$ at DC		V	27
Voltage type for actuation			DC
Rated operation current $I_e$ at AC-3, 400 V		A	38
Number of N/Cs as main contact			0
Motor rating at AC-3, 400 V		kWh	18.5

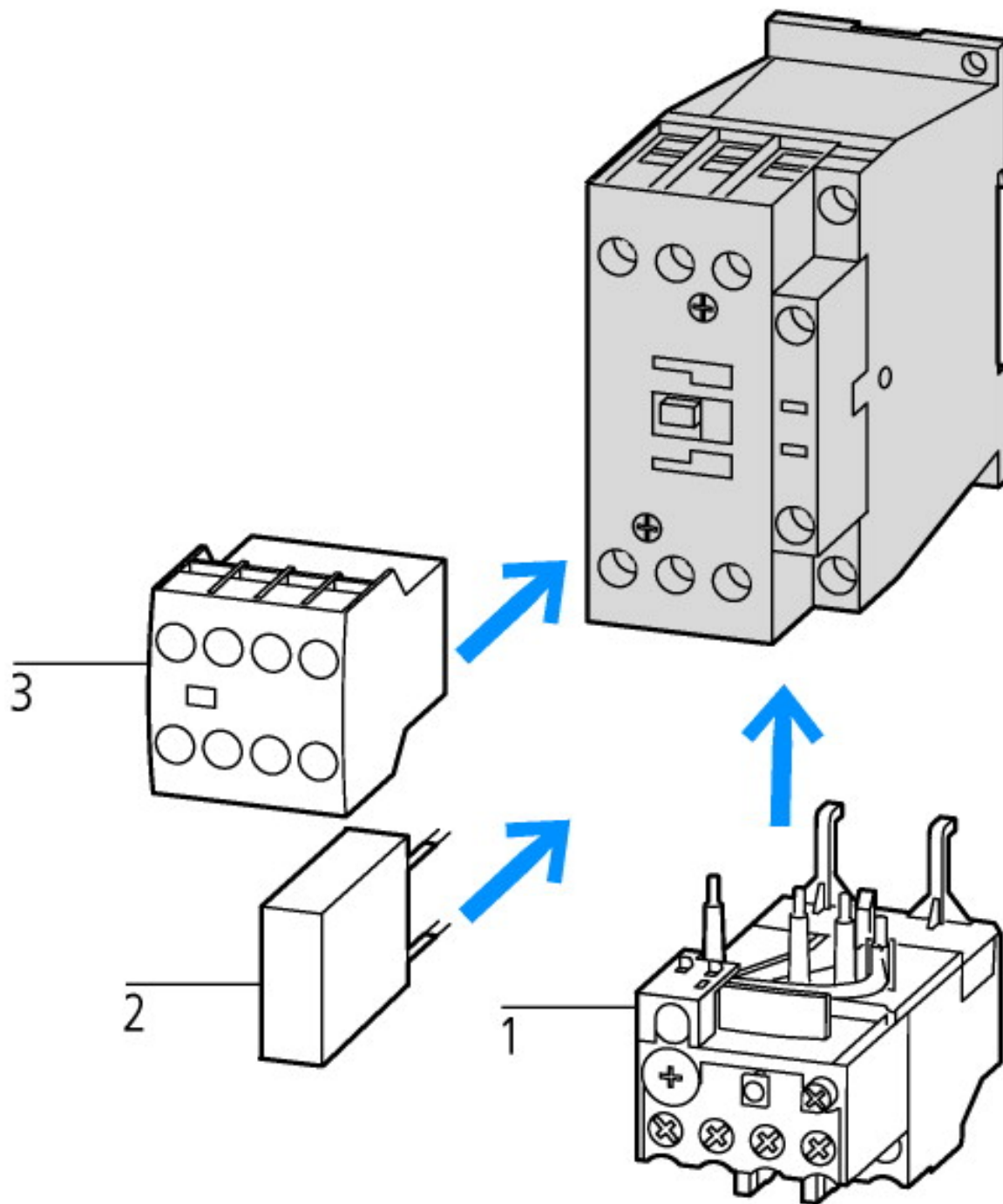

- 1: Overload relay
- 2: Suppressor
- 3: Auxiliary contact modules

Projektieren

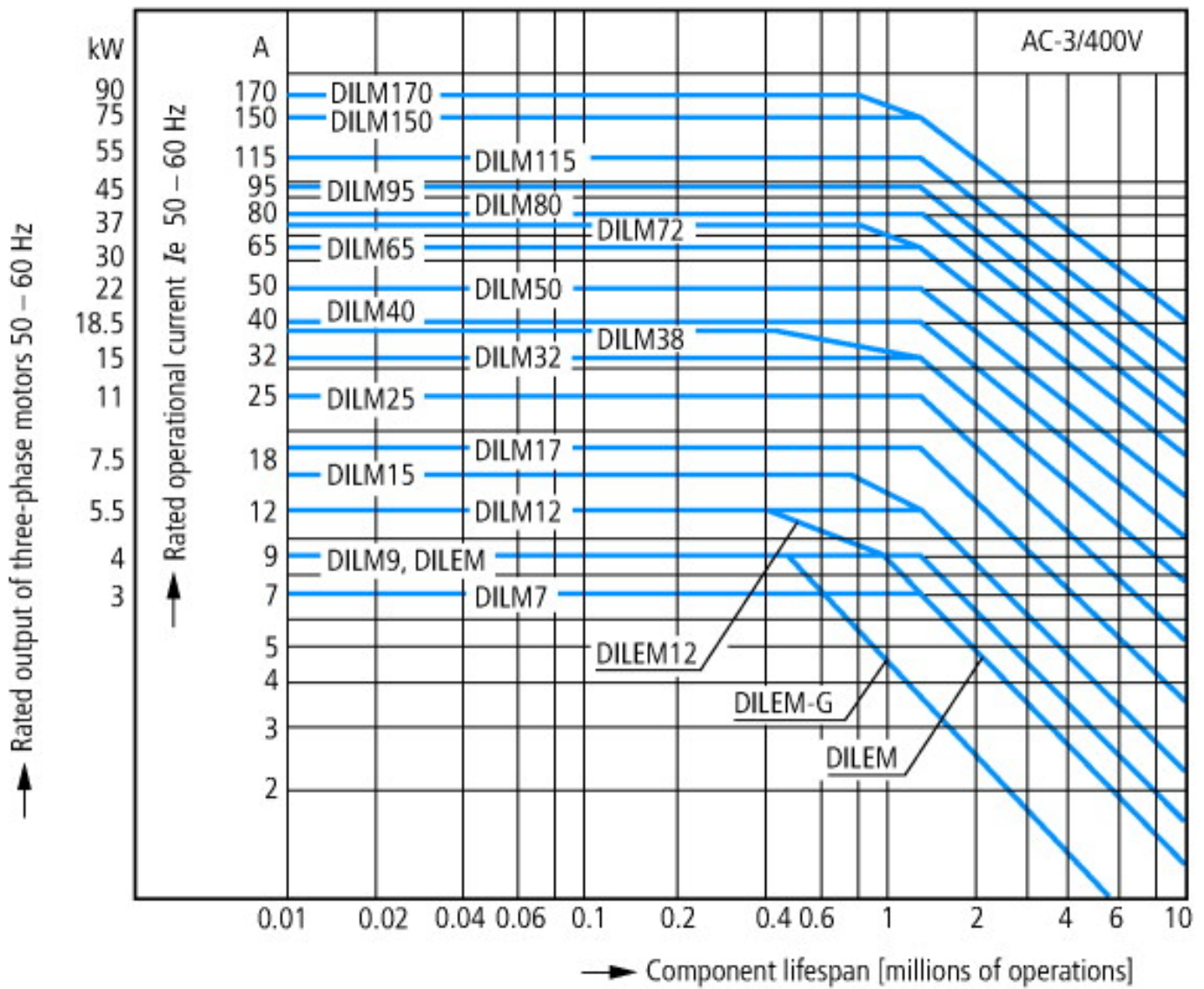

- Squirrel-cage motor
- Operating characteristics
- Starting: from rest
- Stopping: after attaining full running speed
- Electrical characteristics
- Make: up to 6 x rated motor current
- Break: up to 1 x rated motor current
- Utilization category
- 100 % AC-3
- Typical applications
- Compressors
- Lifts
- Mixers
- Pumps
- Escalators
- Agitators
- Fans
- Conveyor belts
- Centrifuges
- Hinged flaps
- Bucket-elevators
- Air conditioning system
- General drives in manufacturing and processing machines

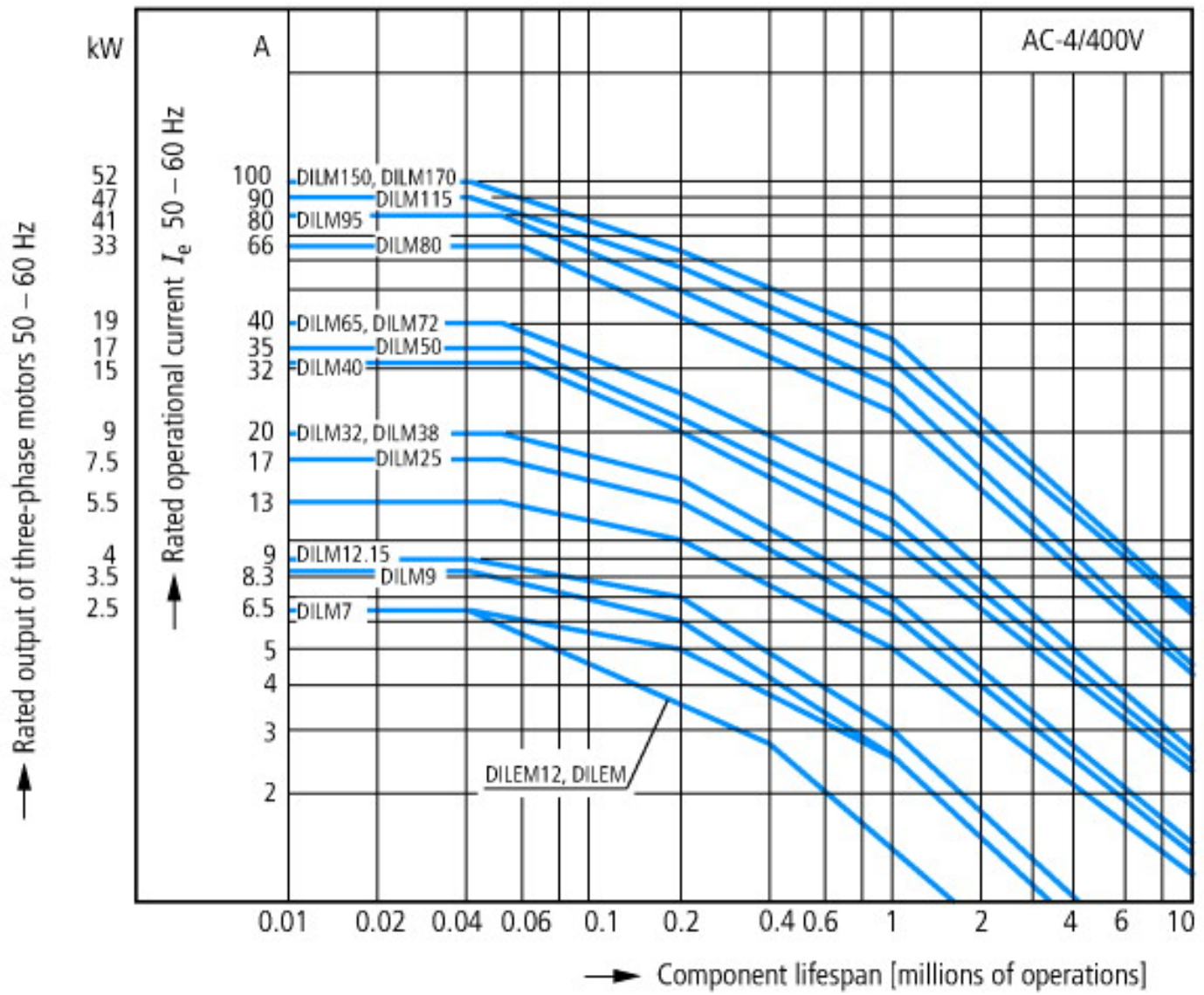

- Extreme switching duty
- Squirrel-cage motor
- Operating characteristics
- Inching, plugging, reversing
- Electrical characteristics
- Make: up to 6 x rated motor current
- Break: up to 6 x rated motor current
- Utilization category
- 100 % AC-4
- Typical applications
- Printing presses
- Wire-drawing machines
- Centrifuges
- Special drives for manufacturing and processing machines

### CAD-Data

Product standards CAD data:

<http://eaton-moeller.partcommunity.com>

### Dimensions



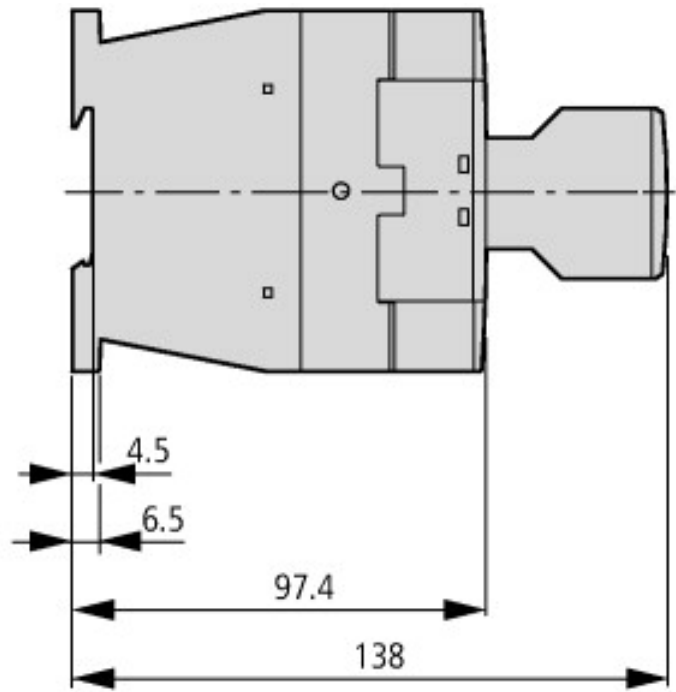
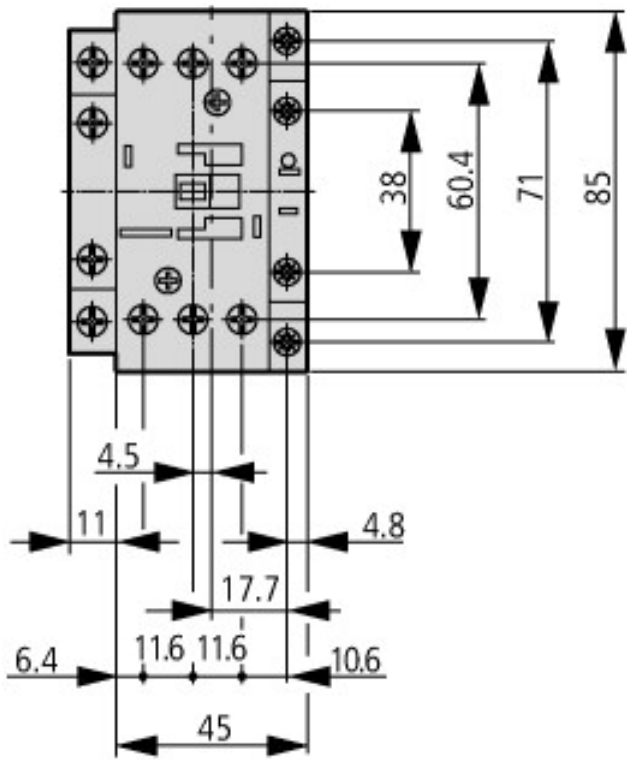

Contacteur avec module de contact auxiliaire

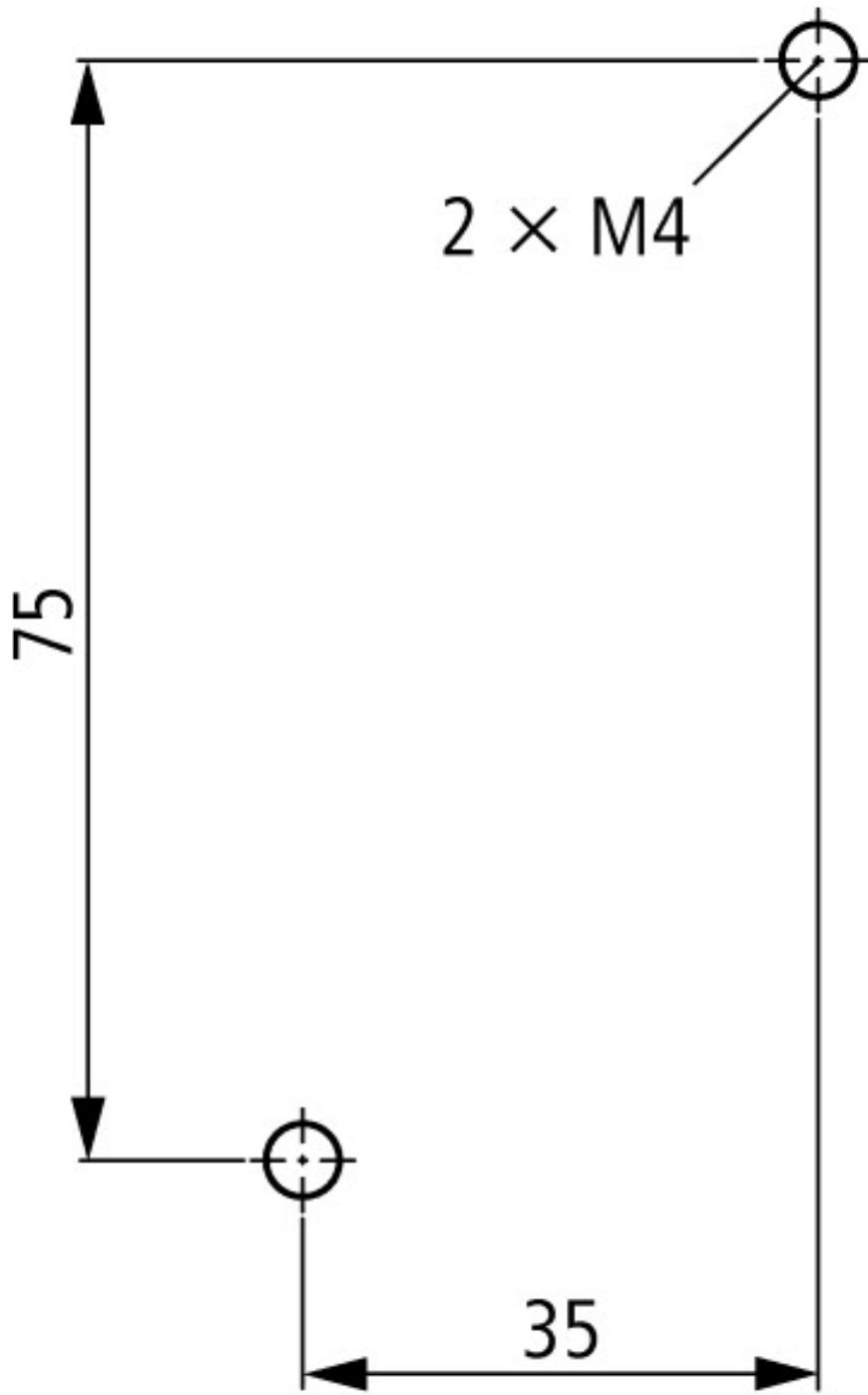

Lateral clearance to earthed parts: 6 mm

[Additional product information \(links\)](#)