

**Contactor,30kW/400V,AC-operated**





Powering Business Worldwide™

**Part no.** DILM65-22(230V50HZ,240V60H

**Article no.** 277926

**Program**

Product range			Contactors
Application			Contactors for Motors
Subrange			Complete devices up to 170 A
Connection technique			Screw terminals
Rated operational current			
AC-3			
380 V 400 V	$I_e$	A	65
AC-1			
Conventional free air thermal current, 3 pole, 50 - 60 Hz			
Open			
at 40 °C	$I_{th}=I_e$	A	98
Max. rating for three-phase motors, 50 - 60 Hz			
AC-3			
220 V 230 V	P	kW	20
380 V 400 V	P	kW	30
660 V 690 V	P	kW	35
AC-4			
220 V 230 V	P	kW	7
380 V 400 V	P	kW	12
660 V 690 V	P	kW	17
Contacts			
Auxiliary contacts:  = safety function, by positive opening to IEC/EN 60947-5-1			
N/O = Normally open			2 N/O
N/C = Normally closed			2 N/C
<b>Instructions</b>			Contacts to EN 50012. with mirror contact.
Contact sequence			
Voltage AC/DC			AC operation

**Approbatjonen**

Product Standards	IEC/EN 60947-4-1; UL 508; CSA-C22.2 No. 14-05; CE marking
UL File No.	E29096
UL CCN	NLDX
CSA File No.	012528
CSA Class No.	2411-03, 3211-04
NA Certification	UL listed, CSA certified
Specially designed for NA	No

**General**

Standards			IEC/EN 60947, VDE 0660, UL, CSA
Lifespan, mechanical			
AC operated	Operations	$x 10^6$	10
DC operated	Operations	$x 10^6$	10
Operating frequency, mechanical			
AC operated	Operations/h		5000
DC operated	Operations/h		5000
Climatic proofing			Damp heat, constant to IEC 60068-2-78

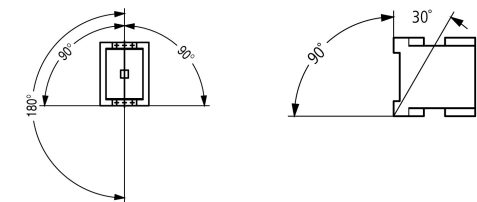
			Damp heat, cyclic to IEC 60068-2-30
Ambient temperature		°C	
Open		°C	- 25 - 60
Enclosed		°C	- 25 - 40
Storage		°C	- 40 - 80
Mounting position, AC- and DC operated			
Mechanical shock resistance (IEC/EN 60068-2-27)			
Half-sinusoidal shock, 10 ms			
Main contacts			
N/O contact	g		10
Auxiliary contacts			
N/O contact	g		7
N/C contact	g		5
Mechanical shock resistance (IEC/EN 60068-2-27) when tabletop-mounted			
Half-sinusoidal shock, 10 ms			
Main contacts			
N/O contact	g		10
Auxiliary contacts			
N/O contact	g		7
N/C contact	g		5
Protection type			IP00
Protection against direct contact when actuated from front (EN 90274)			Finger- and back-of-hand proof
Weight			
AC operated	kg		0.9
DC operated	kg		1.1
Terminal capacity main cable			
Solid	mm <sup>2</sup>		1 x (0.75 - 16) 2 x (0.75 - 16)
Flexible with ferrule	mm <sup>2</sup>		1 x (0.75 - 35) 2 x (0.75 - 25)
Stranded	mm <sup>2</sup>		1 x (16 - 50) 2 x (16 - 35)
Solid or stranded	AWG		12 - 2
Flat conductor	Number of segments x width x thickness	mm	2 x (6 x 9 x 0.8)
Main cable connection screw/bolt			M6
Tightening torque	Nm		3.3
Terminal capacity control circuit cables			
Solid	mm <sup>2</sup>		1 x (0.75 - 4) 2 x (0.75 - 4)
Flexible with ferrule	mm <sup>2</sup>		1 x (0.75 - 2.5) 2 x (0.75 - 2.5)
Solid or stranded	AWG		18 - 14
Control circuit cable connection screw/bolt			M3.5
Tightening torque	Nm		1.2
Tool			
Main cable			
Pozidriv screwdriver	Size		2
Standard screwdriver	mm		0.8 x 5.5 1 x 6
Control circuit cables			

Pozidriv screwdriver		Size	2
Standard screwdriver		mm	0.8 x 5.5 1 x 6
Terminal capacity control circuit cables			
Solid		mm <sup>2</sup>	1 x (0.75 - 2.5) 2 x (0.75 - 2.5)
Flexible		mm <sup>2</sup>	1 x (0.75 - 2.5) 2 x (0.75 - 2.5)
Flexible with ferrule		mm <sup>2</sup>	1 x (0.75 - 1.5) 2 x (0.75 - 1.5)
Solid or stranded		AWG	18 - 14
Tool			
Stripping length		mm	10
Screwdriver blade width		mm	3.5

### Main conducting paths

Rated impulse withstand voltage	$U_{imp}$	V AC	8000
Overvoltage category/pollution degree			III/3
Rated insulation voltage	$U_i$	V AC	690
Rated operational voltage	$U_e$	V AC	690
Safe isolation to VDE 0106 Part 101 and Part 101/A1			
between coil and contacts		V AC	440
between the contacts		V AC	440
Making capacity (p.f. to IEC/EN 60947)			
	Up to 690 V	A	910
Breaking capacity			
220/230 V		A	650
380/400 V		A	650
500 V		A	650
660/690 V		A	370
Short-circuit rating			
Short-circuit protection maximum fuse			
Type "2" coordination			
400 V	gG/gL 500 V	A	125
690 V	gG/gL 690 V	A	80
Type "1" coordination			
400 V	gG/gL 500 V	A	250
690 V	gG/gL 690 V	A	100

### AC

AC-1 duty			
Conventional free air thermal current, 3 pole, 50 - 60 Hz			
Open			
at 40 °C	$I_{th} = I_e$	A	98
at 50 °C	$I_{th} = I_e$	A	88
at 55 °C	$I_{th} = I_e$	A	83
at 60 °C	$I_{th} = I_e$	A	80
enclosed	$I_{th}$	A	72
Conventional free air thermal current, 1 pole			
open	$I_{th}$	A	200
enclosed	$I_{th}$	A	180
AC-3 duty			
Rated operational current AC-3 open, 50 - 60 Hz, 3 pole	$I_e$		

220/230 V	$I_e$	A	65
240 V	$I_e$	A	65
380/400 V	$I_e$	A	65
415 V	$I_e$	A	65
440V	$I_e$	A	65
500 V	$I_e$	A	65
660/690 V	$I_e$	A	37
Motor rating	P	kWh	
220/230 V	P	kW	20
240V	P	kW	22
380/400 V	P	kW	30
415 V	P	kW	39
440 V	P	kW	41
500 V	P	kW	47
660/690 V	P	kW	35
AC-4 duty			
Rated operational current AC-4 open, 50 - 60 Hz, 3 pole	$I_e$		
220/230 V	$I_e$	A	25
240 V	$I_e$	A	25
380/400 V	$I_e$	A	25
415 V	$I_e$	A	25
440 V	$I_e$	A	25
500 V	$I_e$	A	25
660/690 V	$I_e$	A	20
Motor rating	P	kWh	
220/230 V	P	kW	7
240 V	P	kW	7.5
380/400 V	P	kW	12
415 V	P	kW	13
440 V	P	kW	14
500 V	P	kW	16
660/690 V	P	kW	17

## DC

Rated operational current, open			
DC-1 operation			
60 V	$I_e$	A	72
110 V	$I_e$	A	72
220 V	$I_e$	A	65
440 V	$I_e$	A	2.9
DC-3 operation			
60 V	$I_e$	A	72
110 V	$I_e$	A	72
220 V	$I_e$	A	35
440 V	$I_e$	A	0.6
DC-5 operation			
60 V	$I_e$	A	72
110 V	$I_e$	A	72
220 V	$I_e$	A	35
440 V	$I_e$	A	0.6

## Current heat loss (3 pole)

Current heat loss at $I_{th}$		W	28.8
Current heat loss at $I_e$ to AC-3/400 V		W	19
Impedance per pole		mΩ	1.5

## Magnet systems

Voltage tolerance		$x U_c$	
AC operated	Pick-up	$x U_c$	0.8 - 1.1
Drop-out voltage AC operated	Drop-out	$x U_c$	0.3 - 0.6
DC operated	Pick-up	$x U_c$	0.7 - 1.2
Notes			at least smoothed two-phase bridge rectifier or three-phase rectifier
DC operated	Drop-out	$x U_c$	0.15 - 0.6
Power consumption of the coil in a cold state and $1.0 x U_c$			
50 Hz	Pick-up	VA	149
50 Hz	Sealing	VA	16
50 Hz	Sealing	W	4.3
60 Hz	Pick-up	VA	178
60 Hz	Sealing	VA	19
60 Hz	Sealing	W	5.3
50/60 Hz	Pick-up	VA	168 154
50/60 Hz	Sealing	VA	22 14
50/60 Hz	Sealing	W	5.3 4.3
DC operated	Pick-up	W	24
DC operated	Sealing	W	0.5
Duty factor		% DF	100
Switching times at 100 % $U_c$ (approximate values)			
Main contacts			
AC operated			
Closing delay		ms	12 - 18
Opening delay		ms	8 - 13
DC operated		ms	
Closing delay		ms	54
Opening delay		ms	24
Arcing time		ms	10
Lifespan, mechanical; Coil 50/60 Hz	at 50 Hz		Mechanical lifespan at 50 Hz approx. 30% lower than under "Technical data, general"

## Electromagnetic compatibility (EMC)

Emitted interference			to EN 60947-1
Interference immunity			to EN 60947-1

## Technical data according to ETIM 4.0

Number of main contacts as N/Os			3
Rated operation current $I_e$ at AC-1, 400 V			98
Connection type main circuit			Screw connection
Rated control voltage $U_s$ at AC 60HZ		V	240
Number of auxiliary contacts as N/Os			2
Rated control voltage $U_s$ at AC 50HZ		V	230
Number of auxiliary contacts as N/Cs			2
Suitable for rail-mounting			No
Rated control voltage $U_s$ at DC		V	0
Voltage type for actuation			AC
Rated operation current $I_e$ at AC-3, 400 V		A	65
Number of N/Cs as main contact			0
Motor rating at AC-3, 400 V		kWh	30

## Characteristics

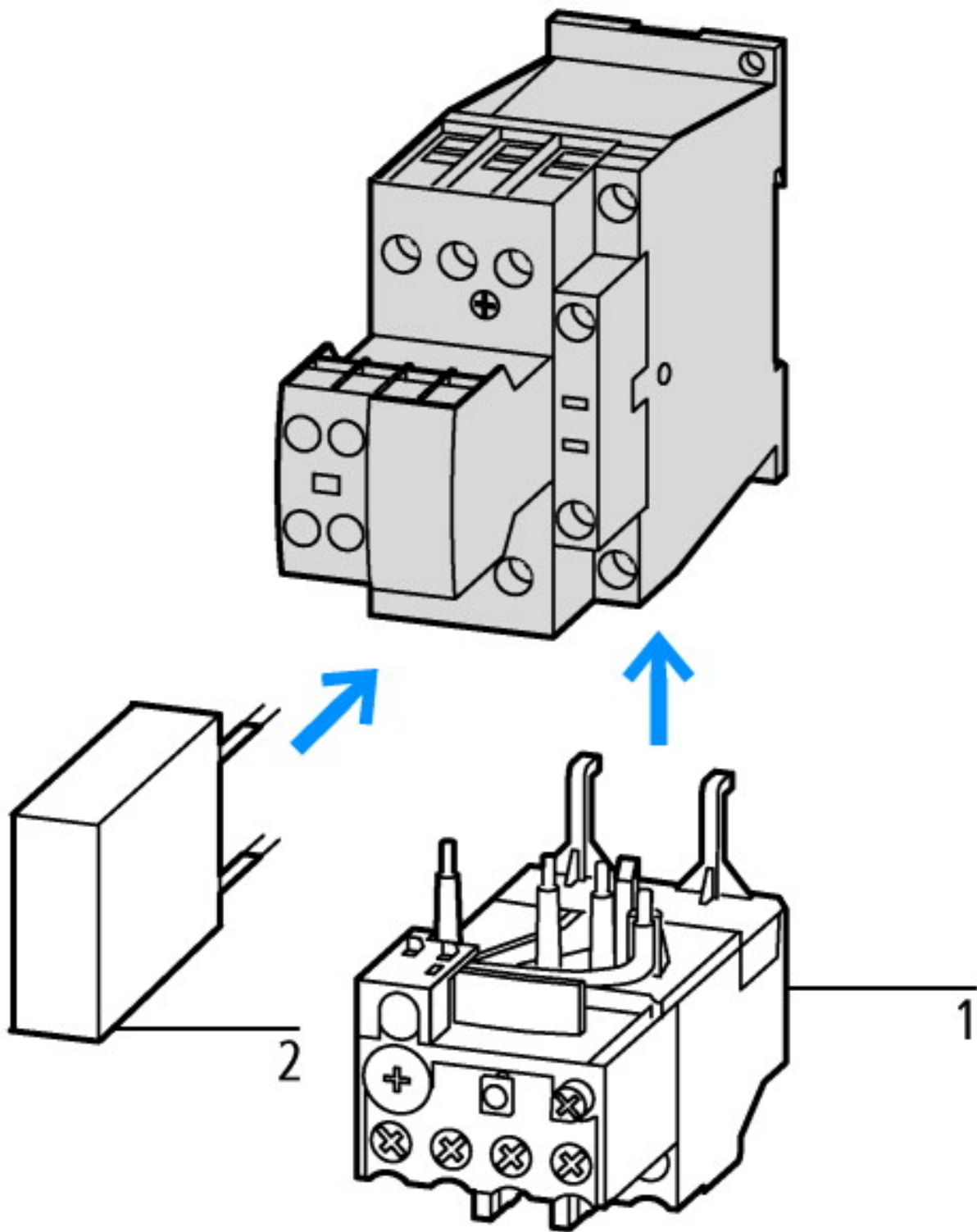

1: Overload relay  
2: Suppressor

# DILM1000-XHI(C)..

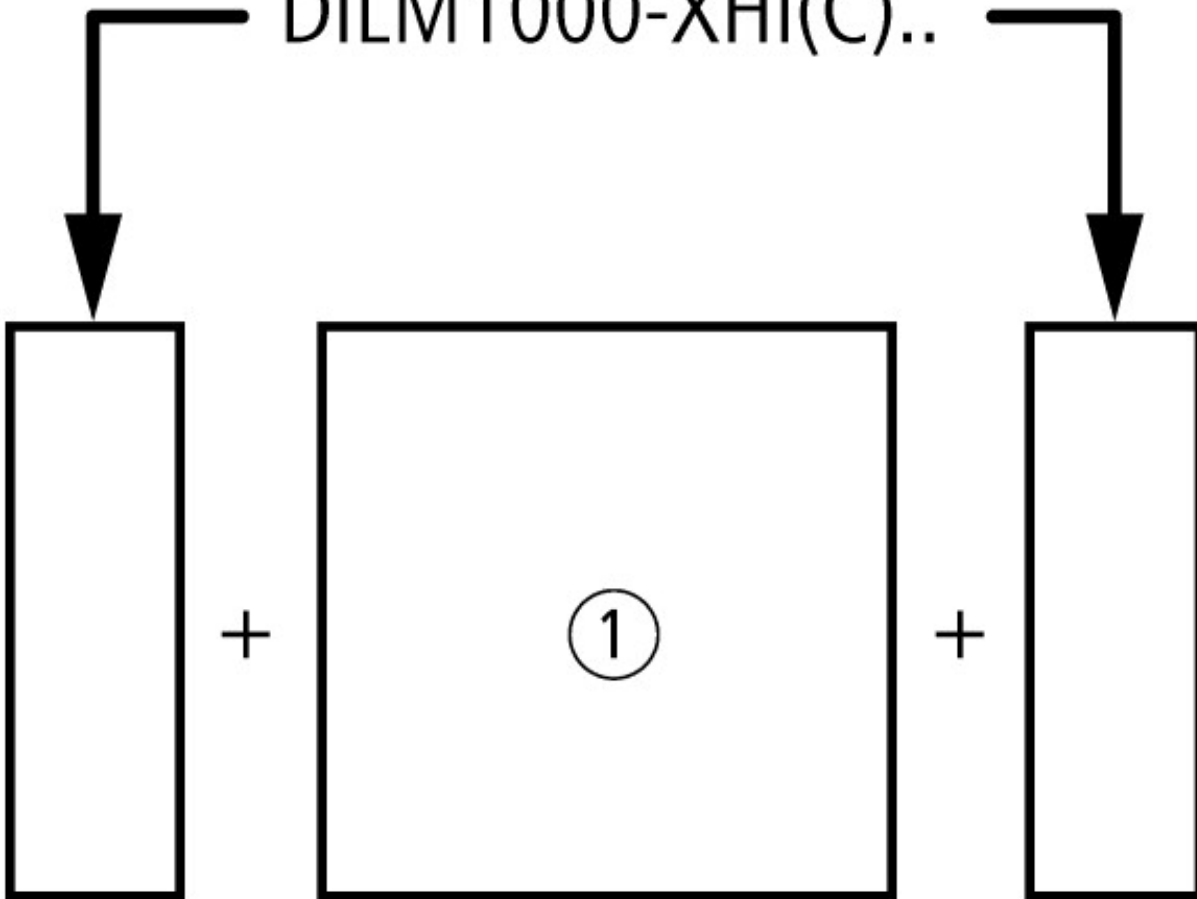

on the side: 2 x DILM1000-XHI(V)11-SI; surface mounting: 1 x DILM150-XHIA11  
on the side: 2 x DILM1000-XHI(V)11-SA; surface mounting: 1 x DILM150-XHI (2 pole)  
on the side: 1 x DILM1000-XHI(V)11-SI; surface mounting: 1 x DILM150-XHIA22  
on the side: 1 x DILM1000-XHI(V)11-SA; surface mounting: 1 x DILM150-XHI (4 pole)

Projektieren

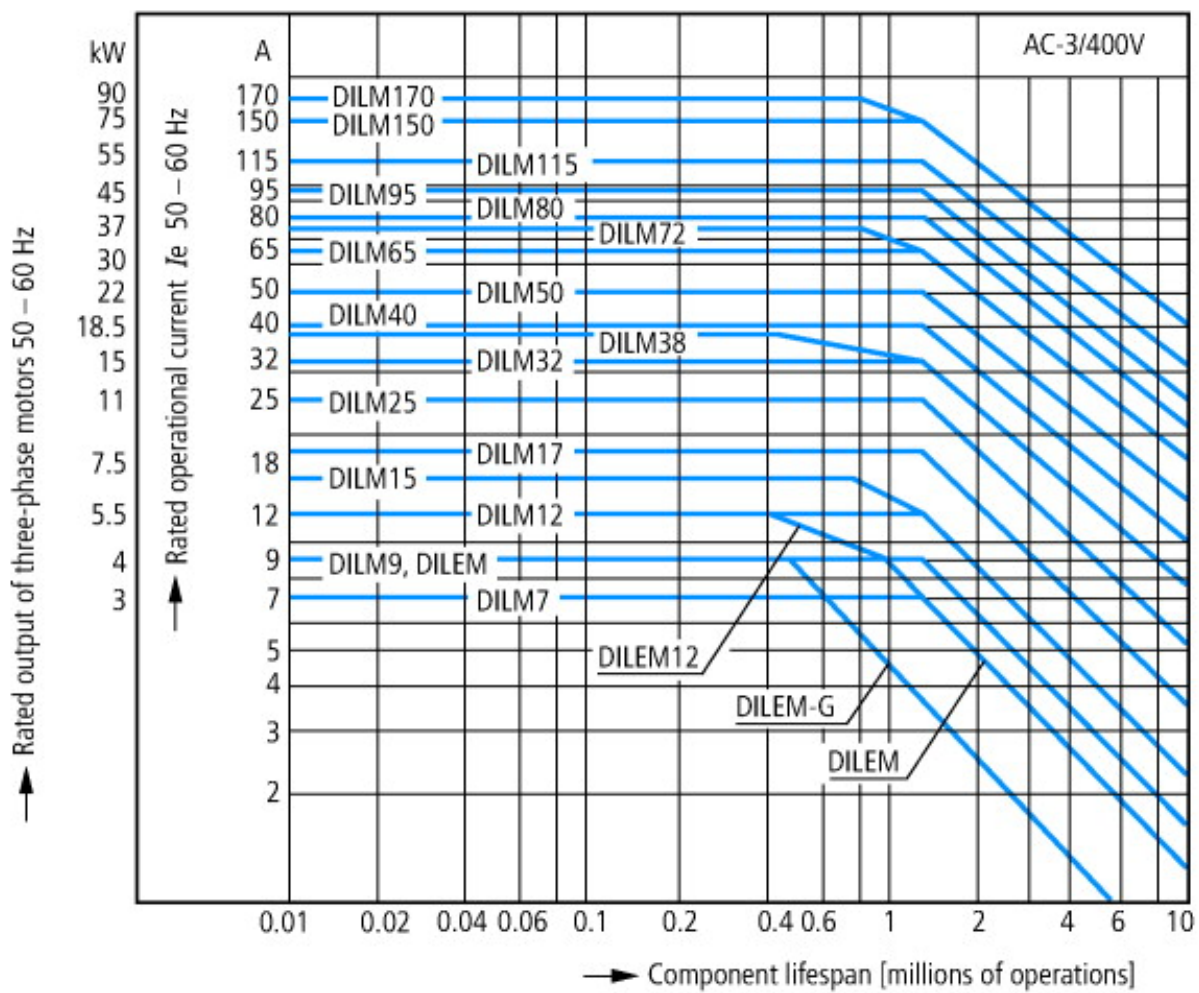

- Squirrel-cage motor
- Operating characteristics
- Starting: from rest
- Stopping: after attaining full running speed
- Electrical characteristics
- Make: up to 6 x rated motor current
- Break: up to 1 x rated motor current
- Utilization category
- 100 % AC-3
- Typical applications
- Compressors
- Lifts
- Mixers
- Pumps
- Escalators
- Agitators
- Fans
- Conveyor belts
- Centrifuges
- Hinged flaps
- Bucket-elevators
- Air conditioning system
- General drives in manufacturing and processing machines



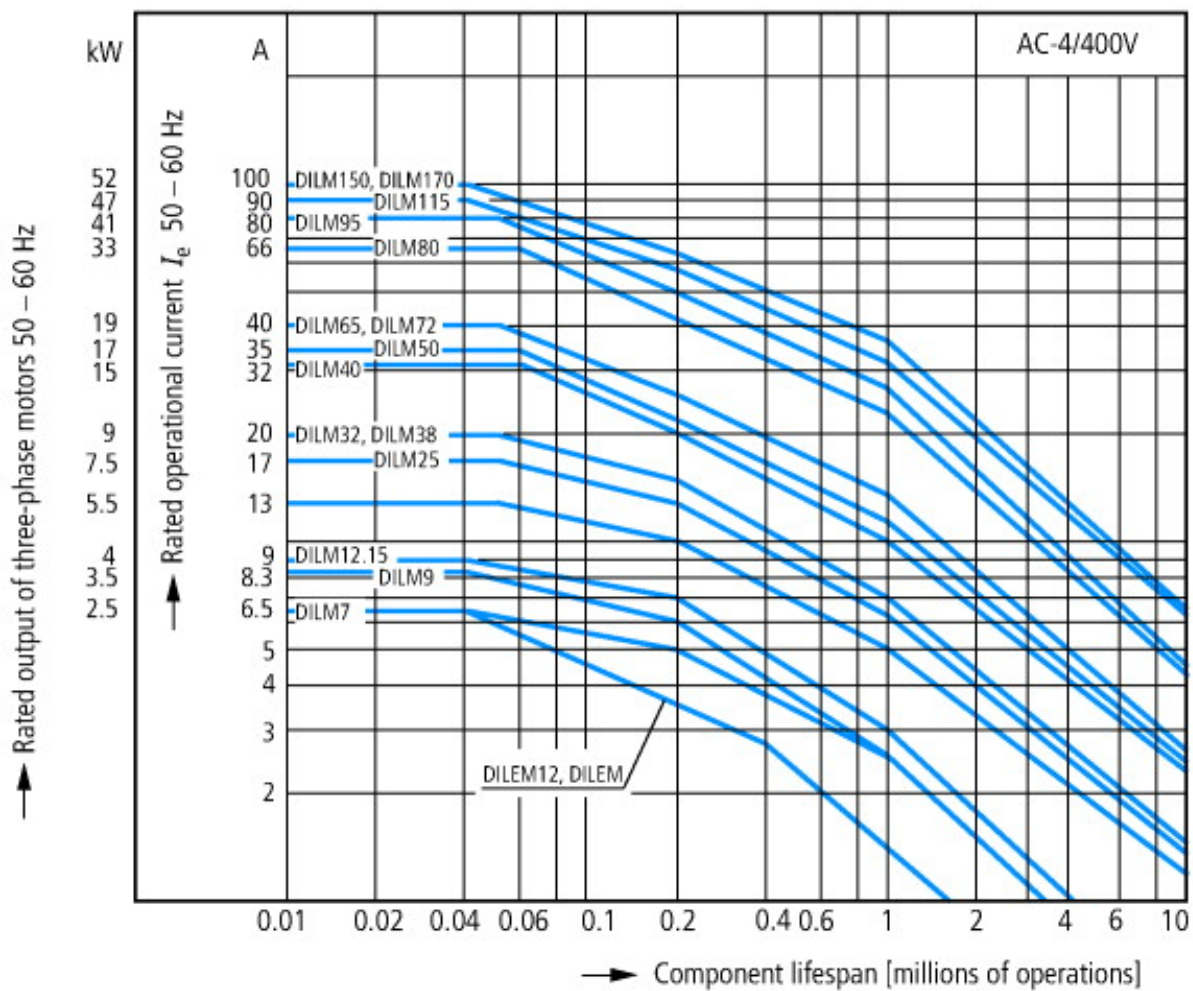

- Extreme switching duty
- Squirrel-cage motor
- Operating characteristics
- Inching, plugging, reversing
- Electrical characteristics
- Make: up to 6 x rated motor current
- Break: up to 6 x rated motor current
- Utilization category
- 100 % AC-4
- Typical applications
- Printing presses
- Wire-drawing machines
- Centrifuges
- Special drives for manufacturing and processing machines

## CAD-Data

Product standards CAD data:

<http://eaton-moeller.partcommunity.com>

## Dimensions

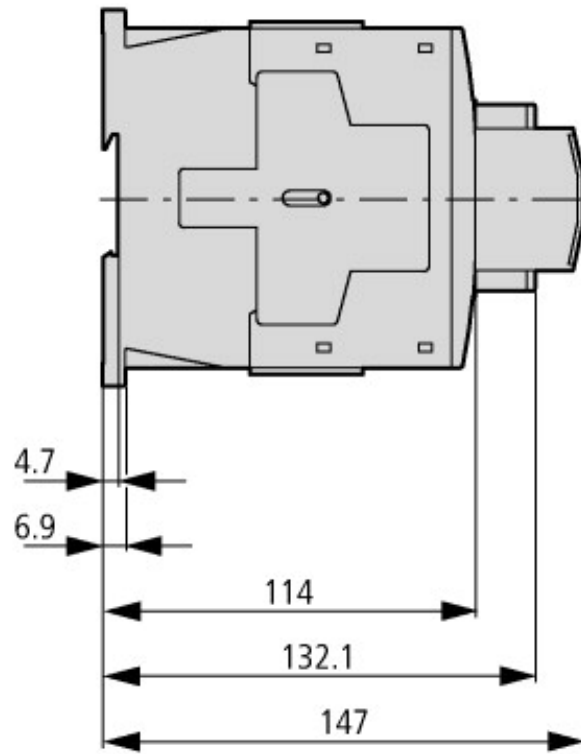
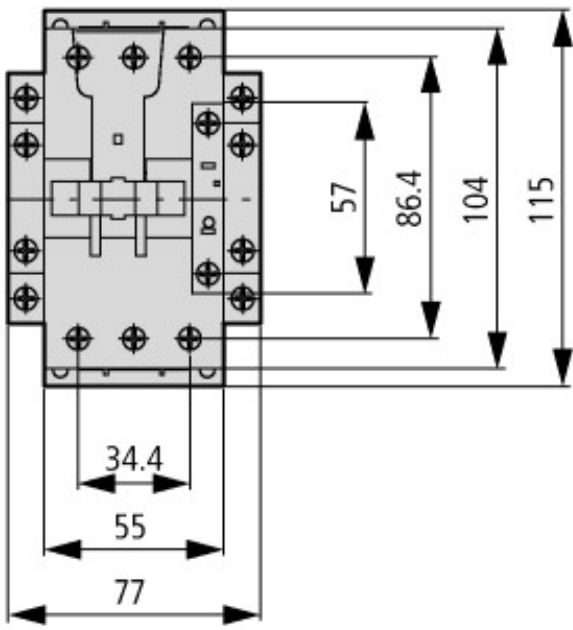

Contacteur avec module de contact auxiliaire

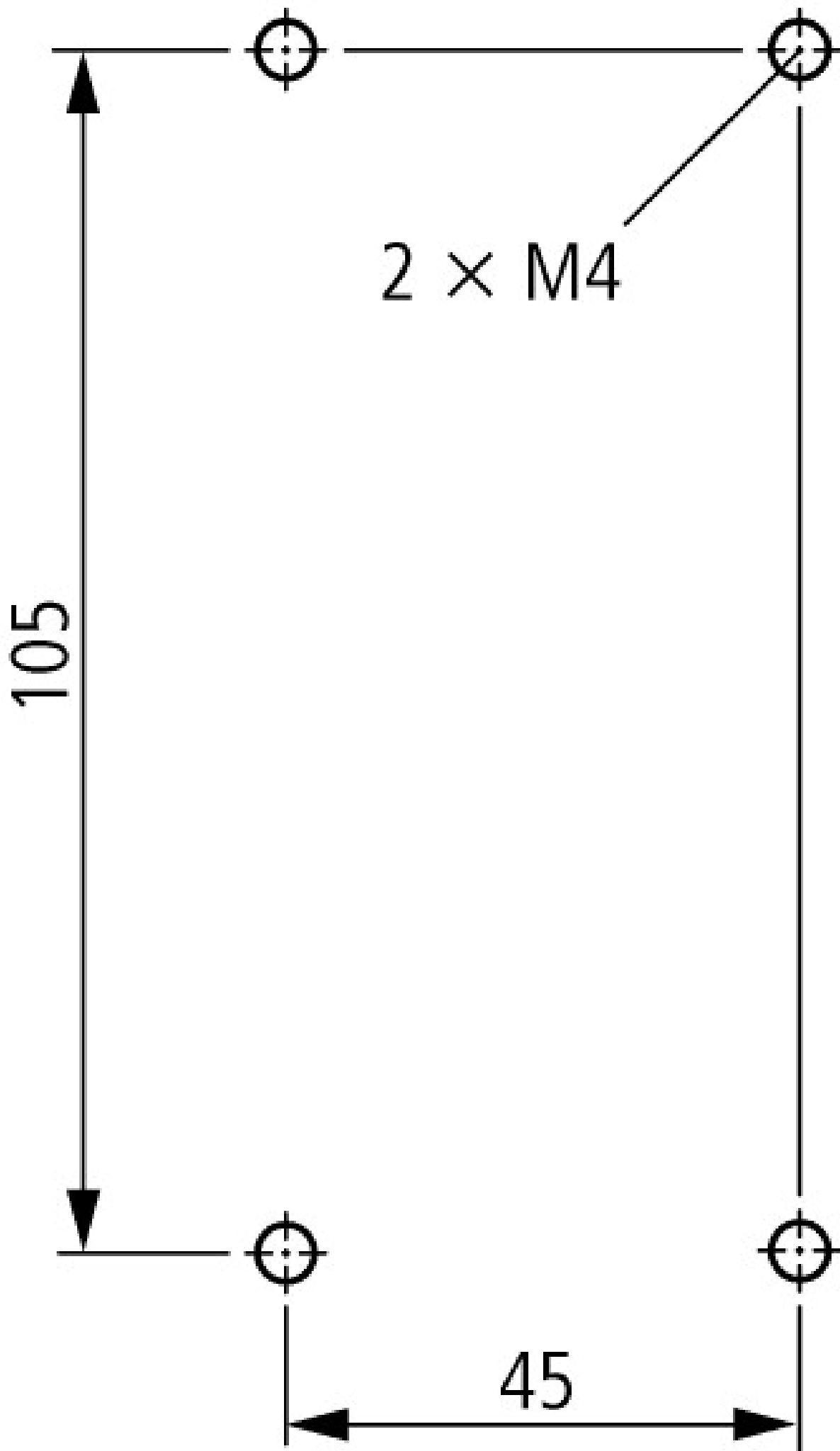

Lateral clearance to earthed parts: 6 mm

## Additional product information (links)

IL03407033Z (AWA2100-2247) Contactor DILM, basic unit	<a href="ftp://ftp.moeller.net/DOCUMENTATION/AWA_INSTRUCTIONS/IL03407033Z2010_10.pdf">ftp://ftp.moeller.net/DOCUMENTATION/AWA_INSTRUCTIONS/IL03407033Z2010_10.pdf</a>
Installation Instructions	<a href="http://www.moeller.net/en/support/instructions_awa.jsp">http://www.moeller.net/en/support/instructions_awa.jsp</a>
Documentation	<a href="http://www.moeller.net/en/support/index.jsp">http://www.moeller.net/en/support/index.jsp</a>
<b>Engineering</b>	
Projektieren	Projektieren
Motor starters and "Special Purpose Ratings" for the North American market	<a href="http://www.moeller.net/binary/ver_techpapers/ver953en.pdf">http://www.moeller.net/binary/ver_techpapers/ver953en.pdf</a>
Busbar Component Adapters for modern Industrial control panels	<a href="http://www.moeller.net/binary/ver_techpapers/ver960en.pdf">http://www.moeller.net/binary/ver_techpapers/ver960en.pdf</a>
The Interaction of Contactors with PLCs	<a href="http://www.moeller.net/binary/ver_techpapers/ver957en.pdf">http://www.moeller.net/binary/ver_techpapers/ver957en.pdf</a>
Standard Compliant and Functionally Safe Engineering Design with Mechanical Auxiliary Contacts	<a href="http://www.moeller.net/binary/ver_techpapers/ver956en.pdf">http://www.moeller.net/binary/ver_techpapers/ver956en.pdf</a>
Switchgear for Luminaires	<a href="http://www.moeller.net/binary/ver_techpapers/ver955en.pdf">http://www.moeller.net/binary/ver_techpapers/ver955en.pdf</a>
Effect of the Cabel Capacitance of Long Control Cables on the Actuation of Contactors	<a href="http://www.moeller.net/binary/ver_techpapers/ver949en.pdf">http://www.moeller.net/binary/ver_techpapers/ver949en.pdf</a>
X-Start - Modern Switching Installations Efficiently Fitted and Wired Securely	<a href="http://www.moeller.net/binary/ver_techpapers/ver938en.pdf">http://www.moeller.net/binary/ver_techpapers/ver938en.pdf</a>
Mirror Contacts for Highly-Reliable Information Relating to Safety-Related Control Functions	<a href="http://www.moeller.net/binary/ver_techpapers/ver944en.pdf">http://www.moeller.net/binary/ver_techpapers/ver944en.pdf</a>
X-Start - New Generation:100 years of Moeler contactors - Continous Progress-	<a href="http://www.moeller.net/binary/ver_techpapers/ver937en.pdf">http://www.moeller.net/binary/ver_techpapers/ver937en.pdf</a>
Switchgear of Power Factor Correction Systems	<a href="http://www.moeller.net/binary/ver_techpapers/ver934en.pdf">http://www.moeller.net/binary/ver_techpapers/ver934en.pdf</a>