

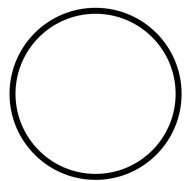



LED element, white, front mount, cage clamp

Part no. **M22-CLED-W**  
 Catalog No. **216569**  
 Eaton Catalog No. **M22-CLED-WQ**  
 EL-Nummer **4355772**  
 (Norway)

### Delivery program

Product range			Accessories
Part group reference (e.g. DIL)			M22
Basic function accessories			LED elements
Single unit/Complete unit			Single unit
Description			Cage Clamp is a registered trademark of Wago Kontakttechnik GmbH/Minden, Germany
Connection technique			Cage Clamp
Fixing			Front fixing
Rated operational voltage	$U_e$	V	12 - 30 V AC/DC, 50/60 Hz
<b>Rated operational current</b>			
Rated operational current min.	$I_e$	mA	8
Rated operational current, max. [units: mA]	$I_e$	mA	15
Power consumption	$P_{max.}$	W	0.26
Lifespan to EN 60064 at $t_a = +25\text{ °C}$	$t_{mean}$ (AC)	h	100000
Degree of Protection			IP20
			at 24 V
<b>Colour</b>			
			White
			
Connection to SmartWire-DT			no
Approval			
<b>Actuator travel and actuation force as per DIN EN 60947-5-1, K.5.4.1</b>			
Minimum force for positive opening	N		0
Connection technique			Cage Clamp

**Notes**

For indicator lights, illuminated pushbutton actuators, and illuminated selector switch actuators, the following applies:

- M22...-R only in combination with M22-LED...-R
- M22...-G only in combination with M22-LED...-G
- M22...-W only in combination with M22-LED...-W
- M22...-Y only in combination with M22-LED...-W
- M22...-B in combination with M22-LED...-W or M22-LED...-B

## Technical data

### General

Standards			IEC 60947-5-1
Operating torque (screw terminals)		Nm	≤ 0.8
Degree of Protection			IP20
Climatic proofing			Damp heat, constant, to IEC 60068-2-78 Damp heat, cyclic, to IEC 60068-2-30
Ambient temperature			
Open		°C	-25 - +70
Storage		°C	- 40 - + 80
Mounting position			As required
Mechanical shock resistance according to IEC 60068-2-27 Shock duration 11 ms, half-sinusoidal		g	> 30
Mechanical shock resistance		g	30 Shock duration 11 ms Sinusoidal according to IEC 60068-2-27
Terminal capacities		mm <sup>2</sup>	
Solid		mm <sup>2</sup>	0.75 - 2.5
Stranded		mm <sup>2</sup>	0.5 - 2.5

### Contacts

Rated impulse withstand voltage	U <sub>imp</sub>	V AC	6000
Rated insulation voltage	U <sub>i</sub>	V	500
Overvoltage category/pollution degree			III/3
Indoor and protected outdoor installation			

## Design verification as per IEC/EN 61439

Technical data for design verification			
Rated operational current for specified heat dissipation	I <sub>n</sub>	A	0
Heat dissipation per pole, current-dependent	P <sub>vid</sub>	W	0
Equipment heat dissipation, current-dependent	P <sub>vid</sub>	W	0
Static heat dissipation, non-current-dependent	P <sub>vs</sub>	W	0.45
Heat dissipation capacity	P <sub>diss</sub>	W	0
Operating ambient temperature min.		°C	-25
Operating ambient temperature max.		°C	70
IEC/EN 61439 design verification			
10.2 Strength of materials and parts			
10.2.2 Corrosion resistance			
10.2.2.1 Verification of thermal stability of enclosures			Meets the product standard's requirements.
10.2.2.2 Verification of resistance of insulating materials to normal heat			Meets the product standard's requirements.
10.2.2.3 Verification of resistance of insulating materials to abnormal heat and fire due to internal electric effects			Meets the product standard's requirements.
10.2.4 Resistance to ultra-violet (UV) radiation			
10.2.5 Lifting			Does not apply, since the entire switchgear needs to be evaluated.
10.2.6 Mechanical impact			
10.2.7 Inscriptions			Meets the product standard's requirements.
10.3 Degree of protection of ASSEMBLIES			
10.4 Clearances and creepage distances			
10.5 Protection against electric shock			Does not apply, since the entire switchgear needs to be evaluated.
10.6 Incorporation of switching devices and components			
10.7 Internal electrical circuits and connections			
10.8 Connections for external conductors			Is the panel builder's responsibility.
10.9 Insulation properties			
10.9.2 Power-frequency electric strength			Is the panel builder's responsibility.
10.9.3 Impulse withstand voltage			Is the panel builder's responsibility.
10.9.4 Testing of enclosures made of insulating material			Is the panel builder's responsibility.

10.10 Temperature rise		The panel builder is responsible for the temperature rise calculation. Eaton will provide heat dissipation data for the devices.
10.11 Short-circuit rating		Is the panel builder's responsibility. The specifications for the switchgear must be observed.
10.12 Electromagnetic compatibility		Is the panel builder's responsibility. The specifications for the switchgear must be observed.
10.13 Mechanical function		The device meets the requirements, provided the information in the instruction leaflet (IL) is observed.

## Technical data ETIM 6.0

Low-voltage industrial components (EG000017) / Lamp holder block for control circuit devices (EC000204)

Electric engineering, automation, process control engineering / Low-voltage switch technology / Command and alarm device / Bulb socket block for command and alarm devices (ecl@ss8.1-27-37-12-09 [AKF027011])

With integrated transformer		No
With integrated voltage decreasing resistor		No
With integrated lamp		Yes
With integrated diode		Yes
Lamp holder		None
Rated voltage Ue at AC 50 Hz	V	12 - 30
Rated voltage Ue at AC 60 Hz	V	12 - 30
Rated voltage Ue at DC	V	12 - 30
Voltage type for actuating		AC/DC
Type of lamp		LED
Connection type auxiliary circuit		Spring clamp connection
Colour lamp		White
Type of fastening		Front fastening

## Approvals

Product Standards		IEC/EN 60947-5; UL 508; CSA-C22.2 No. 14-05; CSA-C22.2 No. 94-91; CE marking
UL File No.		E29184
UL Category Control No.		NKCR
CSA File No.		012528
CSA Class No.		3211-03
North America Certification		UL listed, CSA certified
Degree of Protection		UL/CSA Type: -

## Dimensions

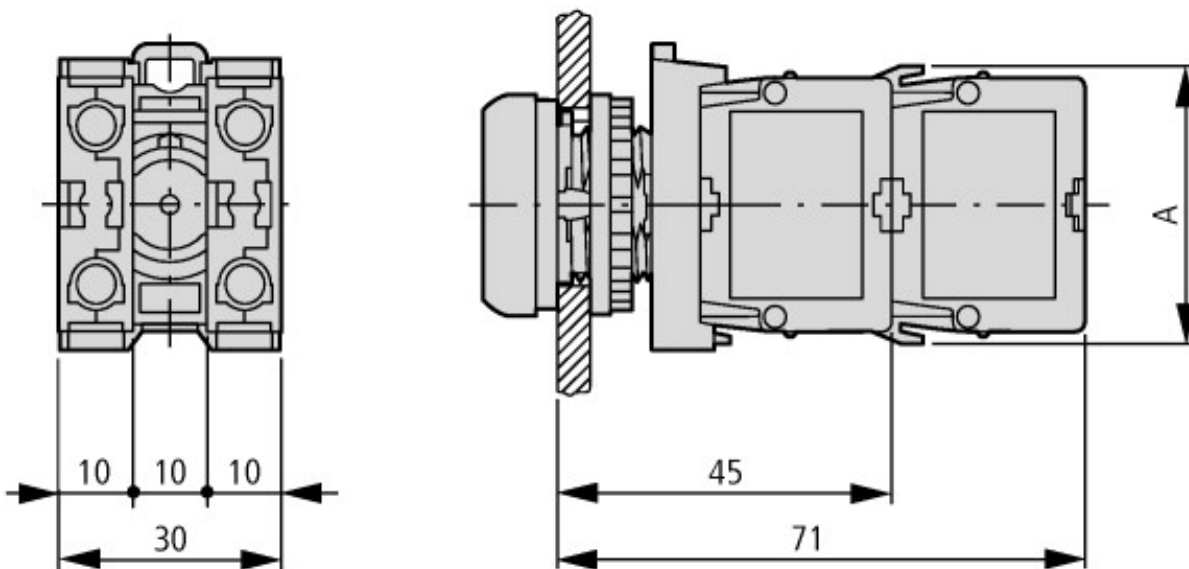

A = 39

Pushbutton with M22-(C)K...  
Pushbutton with M22-(C) LED... + M22-XLED...

## Assets (Links)

### Declaration of Conformity

00002595

## Additional product information (links)

### IL04716002Z (AWA1160-1745) RMQ-Titan System

IL04716002Z (AWA1160-1745) RMQ-Titan System

[ftp://ftp.moeller.net/DOCUMENTATION/AWA\\_INSTRUCTIONS/IL04716002Z2017\\_01.pdf](ftp://ftp.moeller.net/DOCUMENTATION/AWA_INSTRUCTIONS/IL04716002Z2017_01.pdf)