



INDICATOR LIGHTS

Part no.
Article no.

Q25LF-GE/WB
088798



Powering Business Worldwide™

Front dimensions:

Degree of protection IP65

Program

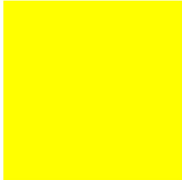
Product range			RMQ16 (drilling dimensions 16 mm)
Basic function			Indicator lights
Single unit/Complete unit			Single unit
Design			Flush
Description			with filament bulb, 24 V
Colour			Yellow
			
Front dimensions			Front dimensions 25 × 25 mm
Front ring			Without front ring
Connection to SmartWire-DT			no

Approvals

UL approval	Yes
CSA approval	Yes
Product Standards	IEC/EN 60947-5; UL 508; CSA-C22.2 No. 14-05; CE marking
UL File No.	E29184
UL CCN	NKCR
CSA File No.	46552
CSA Class No.	3211-03
NA Certification	UL listed, CSA certified
Degree of Protection	UL/CSA Type 1

General

Standards			IEC/EN 60947
Degree of protection, IEC/EN 60529			IP65
Climatic proofing			Damp heat, constant to IEC 60068-2-78 Damp heat, cyclic to IEC 60068-2-30
Ambient temperature		°C	
Open		°C	- 25 - + 60
Enclosed		°C	- 25 - 40
Mounting position			As required
Mechanical shock resistance		g	> 40 according to IEC 60068-2-27 Shock duration 11 ms Sinusoidal
Terminal capacities		mm ²	0.5 - 1.0
Blade terminal			2.8 x 0.8 mm to DIN 46244
Fast-on connectors			2.8 x 0.8 mm to DIN 46247 and IEC 60760

Contacts

Rated impulse withstand voltage	U _{imp}	V AC	800
Rated insulation voltage	U _i	V	250
Overvoltage category/pollution degree			III/3
Rated operational voltage	U _e	V AC	24
Use of insulated ferrule ISH 2,8			>24 V AC/DC recommended >50 V AC or 120 V DC is mandatory, even on unused blade terminals

Technical data according to ETIM 4.0

Type of lens			flush
Width of opening		mm	16
Suitable for number of built-in indicator lights			1
Color lens			yellow
Material front ring			Insulated material
Color bezel			black
Lens design			quadratic
Height meter opening		mm	6
With bezel			YES
Protection type (IP), at front			IP65
Hole diameter		mm	16

Dimensions

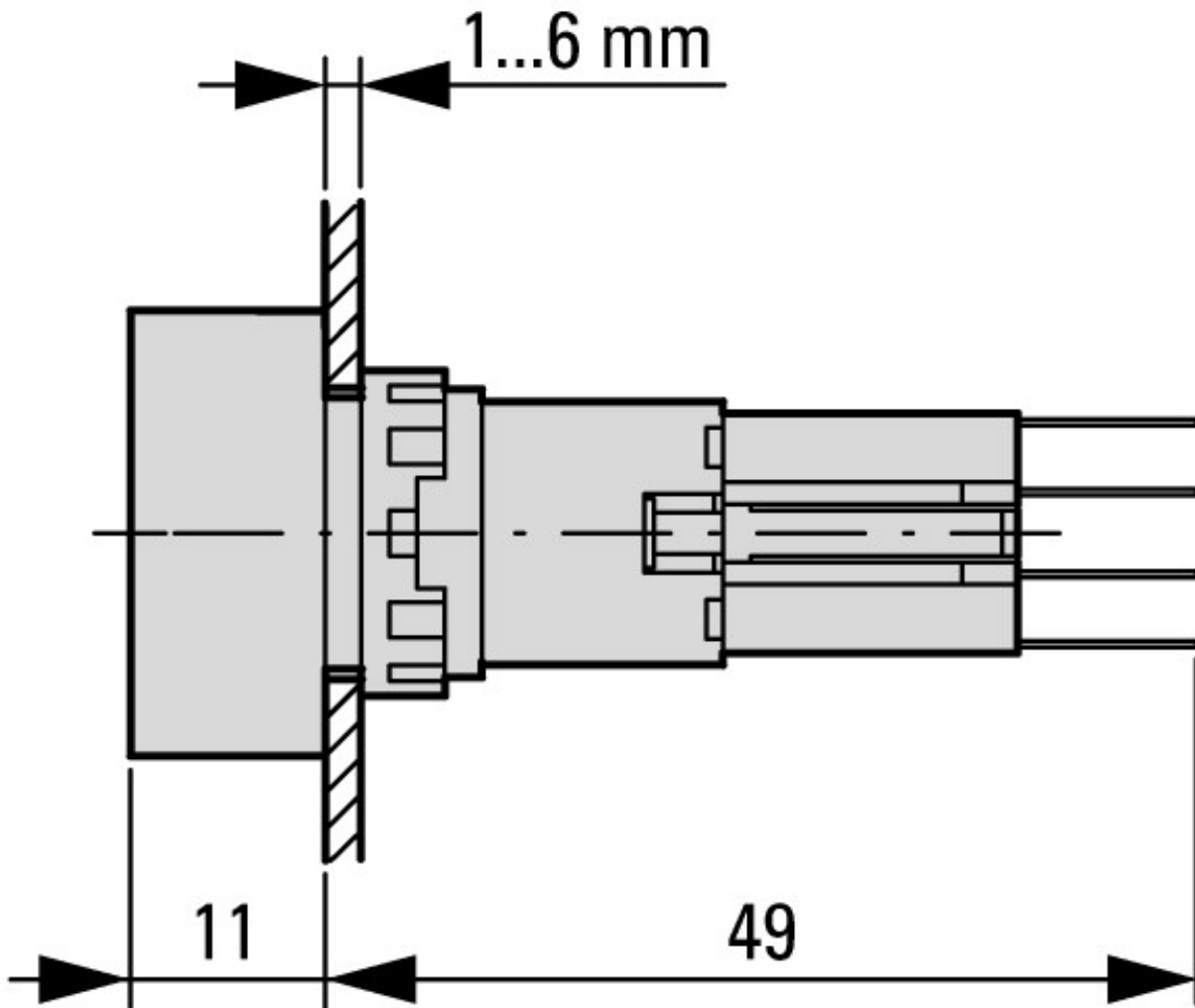

Actuating and indicator elements
Square style

Additional product information (links)

IL04716016Z (AWA1160-1429) Mounting of components

IL04716016Z (AWA1160-1429) Mounting of components

ftp://ftp.moeller.net/DOCUMENTATION/AWA_INSTRUCTIONS/IL04716016Z2011_03.pdf

Labeleditor

ftp://ftp.moeller.net/MFD/EASY-SOFT-PRO/labeleditor_206.exe