



**Change over switch with OFF position Flush mounting**



Powering Business Worldwide™

**Part no.** T0-2-8211/E

**Article no.** 022234



**Delivery programme**

Product range			Switch-disconnectors
Basic function			Changeoverswitches
Part group reference			T0
Design			Flush mounting
Protection type			Front IP65
Emergency stop			without emergency switching off/emergency stop function
			With 0 (Off) position with black thumb grip and front plate
Contact sequence			
Front plate no.			 <b>FS 684</b>
Main conducting paths			
No. of poles		M	2
Max. motor rating			
AC-23A			
400/415 V 50-60 Hz			
400 V	P	kW	6.5
Rated uninterrupted current	I <sub>u</sub>	A	20

**Approvals**

Product Standards  
 UL File No.  
 UL CCN  
 CSA File No.  
 CSA Class No.  
 NA Certification  
 Specially designed for NA  
 Suitable for  
 Degree of Protection

UL 508; CSA-C22.2 No. 14-05; IEC/EN 60947-3; CE marking  
 E36332  
 NLRV  
 12528  
 3211-05  
 UL listed, CSA certified  
 Yes, in combination with "+NA" (105864)  
 Branch circuits  
 IEC: IP65; UL/CSA Type 3R, 12

**General**

Standards			IEC/EN 60947, VDE 0660, IEC/EN 60204, CSA, UL Switch-disconnectors to IEC/EN 60947-3 Load-break switches to IEC/EN 60947-3
Lifespan, mechanical	Operations	x 10 <sup>6</sup>	0.5

Maximum operating frequency		Operations	3000
Climatic proofing		h	Damp heat, constant, to IEC 60068-2-78; Damp heat, cyclical, to IEC 60068-2-30
Ambient temperature		°C	
Open		°C	- 25 - 50
Enclosed		°C	- 25 - 40
Mounting position			As required
Mechanical shock resistance to IEC 60068-2-27	Half-sinusoidal shock 20 ms	g	> 15

## Contacts

Rated operational voltage	$U_e$	V AC	690
Rated impulse withstand voltage	$U_{imp}$	V AC	6000
Overvoltage category/pollution degree			III/3
Rated uninterrupted current	$I_u$	A	
open	$I_u$	A	20
Enclosed	$I_u$	A	20
Load rating with intermittent operation, class 12			
AB 25 % DF		$x I_e$	2
AB 40 % DF		$x I_e$	1.6
AB 60 % DF		$x I_e$	1.3
Short-circuit rating			
Fuse		A gG/ gL	20
Rated short-time withstand current (1 s current)	$I_{cw}$	$A_{rms}$	320
Safe isolation to VDE 0106 Part 101 and Part 101/A1			
between the contacts		V AC	440
Switching angles		°	90 60 45 30
Contact units			11
Double-break contacts			max. 22
Current heat loss per contact at $I_e$		W	0.6

## Terminal capacities

Solid or stranded		mm <sup>2</sup>	1 x (1 - 2.5) 2 x (1 - 2.5)
Flexible with ferrules to DIN 46228		mm <sup>2</sup>	
Flexible with ferrule		mm <sup>2</sup>	1 x (0.75 - 1.5) 2 x (0.75 - 1.5)
Terminal screw			M3.5
Tightening torque		Nm	1

## Switching capacity

AC		$x U_s$	
Rated making capacity $\cos \varphi = 0.35$		A	130
Rated breaking capacity, motor load switch $\cos \varphi = 0.35$		A	
230 V		A	100
400 V		A	110
500 V		A	80
690 V		A	60
Rated operational current 440 V load-break switch AC-21A	$I_e$	A	20
Rating, AC-3 motor load switch	P	kW	
220 V 230 V	P	kW	2.2
230 V Star-delta	P	kW	4
380 V 400 V	P	kW	2.2

400 V Star-delta	P	kW	5.5
500 V	P	kW	5.5
500 V Star-delta	P	kW	7.5
660 V 690 V	P	kW	4
690 V Star-delta	P	kW	5.5
AC-23A Motor load switches (main switches maintenance switches)	P	kW	
230 V	P	kW	3.5
400 V	P	kW	6.5
500 V	P	kW	7.5
Rated operational current control switch AC-15			
220 V 230 V 240 V	I <sub>e</sub>	A	6
380 V 400 V 415 V	I <sub>e</sub>	A	4
500 V	I <sub>e</sub>	A	2
DC		x U <sub>s</sub>	
DC-1, Load-break switches L/R = 1 ms			
Rated operational current	I <sub>e</sub>	A	10
Voltage per contact pair in series		V	60
DC-21A	I <sub>e</sub>	A	
Rated operational current 240 V	I <sub>e</sub>	A	1
240 V Contacts		Quantity	1
DC-23A, motor load switch L/R = 15 ms			
24 V			
Rated operational current	I <sub>e</sub>	A	10
Contacts		Quantity	1
48 V			
Rated operational current	I <sub>e</sub>	A	10
Contacts		Quantity	2
60 V			
Rated operational current	I <sub>e</sub>	A	10
Contacts		Quantity	3
120 V			
Rated operational current	I <sub>e</sub>	A	5
Contacts		Quantity	3
240 V			
Rated operational current	I <sub>e</sub>	A	5
Contacts		Quantity	5
DC-13, Control switches L/R = 50 ms			
Rated operational current	I <sub>e</sub>	A	10
Voltage per contact pair in series		V	32
Control circuit reliability at 24 V DC, 10 mA	Fault probability	H <sub>F</sub>	< 10 <sup>-5</sup> , < 1 fault in 100000 operations

## Notes

**Notes** The following applies for solid, multiwire, and flexible terminal capacities:  
If 2 conductors are being used, a max. difference of 2 cross-section categories is permissible

## Technical data ETIM 4.0

Number of auxiliary contacts as N/Cs			0
With 0 (off) position			YES
Type			Changeover switch
Motor rating at AC-3, 400 V		kWh	4
Number of auxiliary contacts as N/Os			0
Suitable for front mounting			YES
Protection type (IP), at front			IP65
Rated uninterrupted current I <sub>u</sub>		A	20
Suitable for base fixing			No

Number of auxiliary contacts as changeover contacts		0
Suitable for distribution board installation		No
Suitable for rear mounting		No
Complete device in housing		No
Type of control element		Toggle
Number of poles		2
Connection type main circuit		Screw connection

## Characteristics

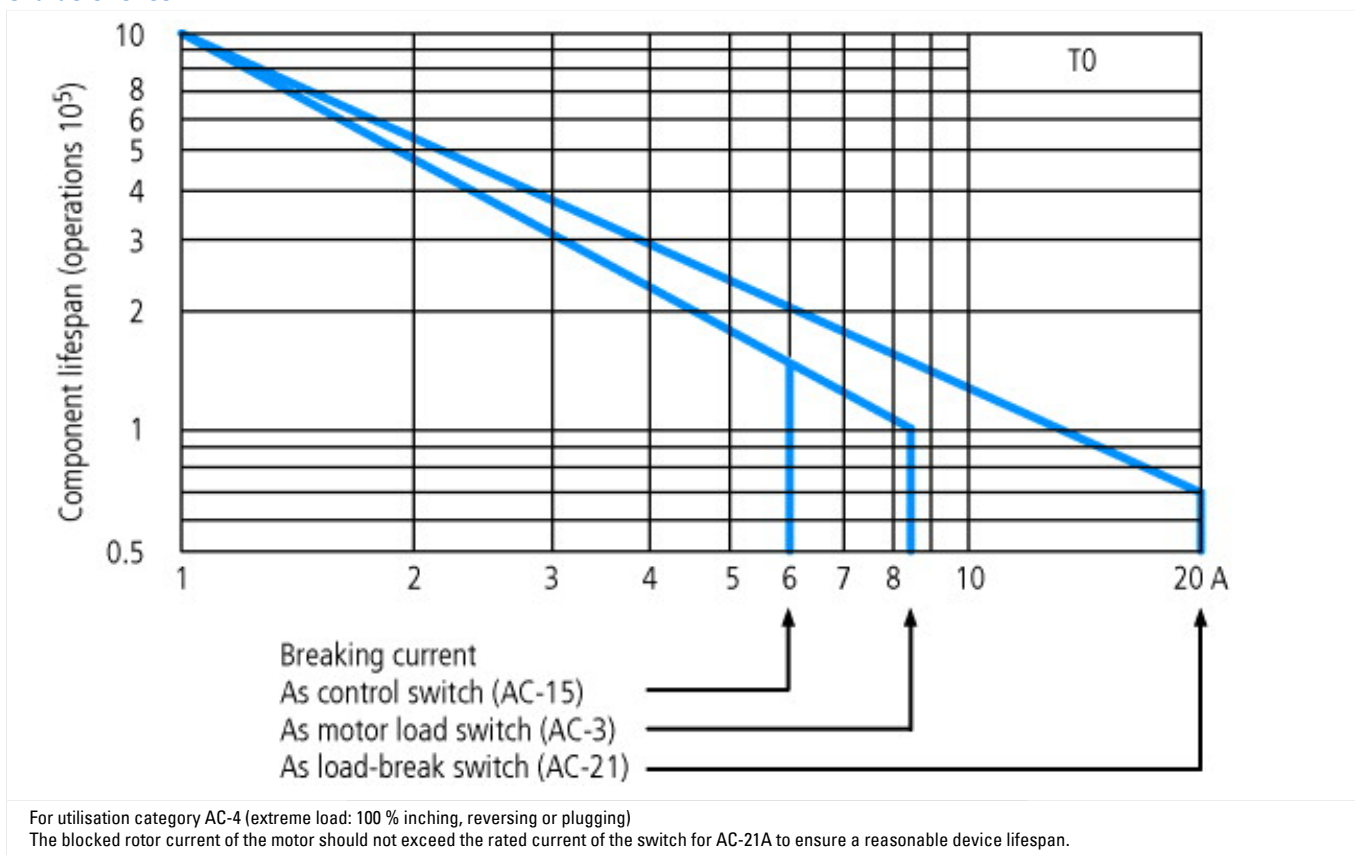

## Dimensions

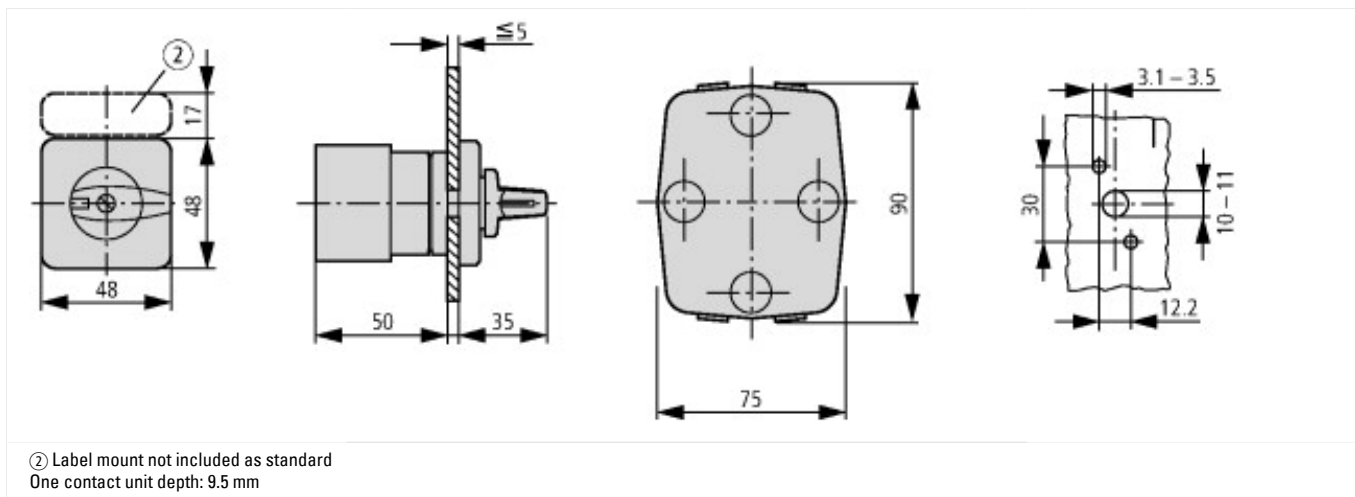

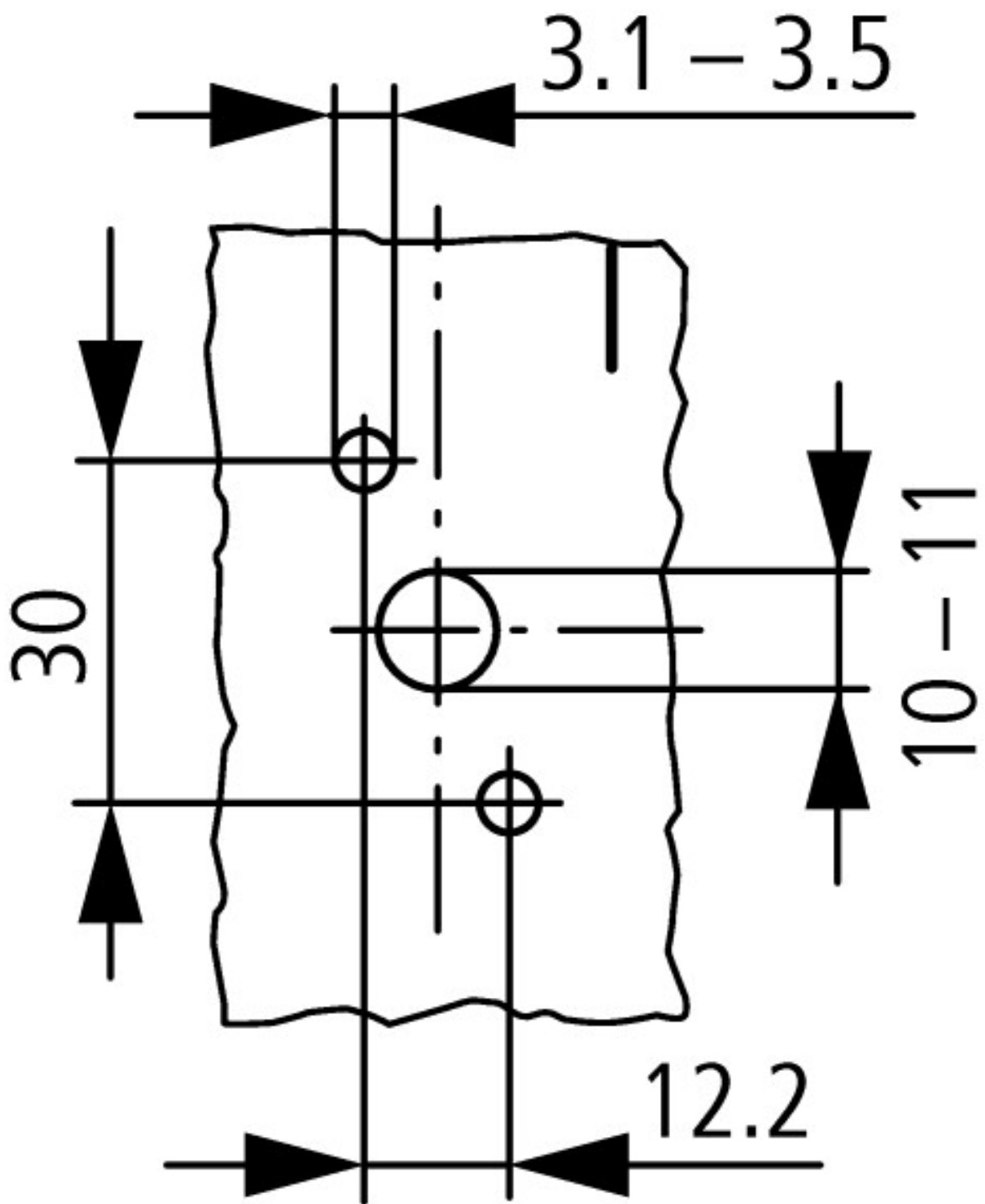

Diameter of drilled hole Door

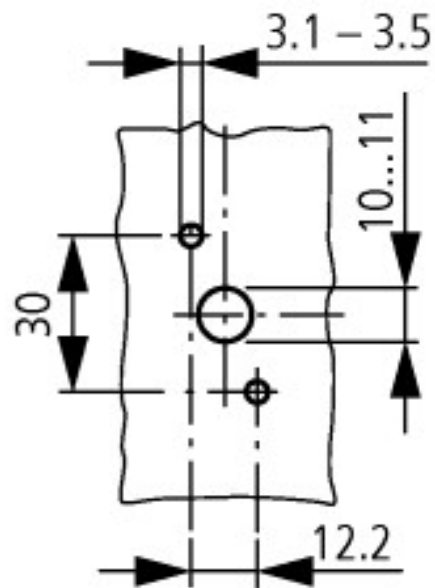
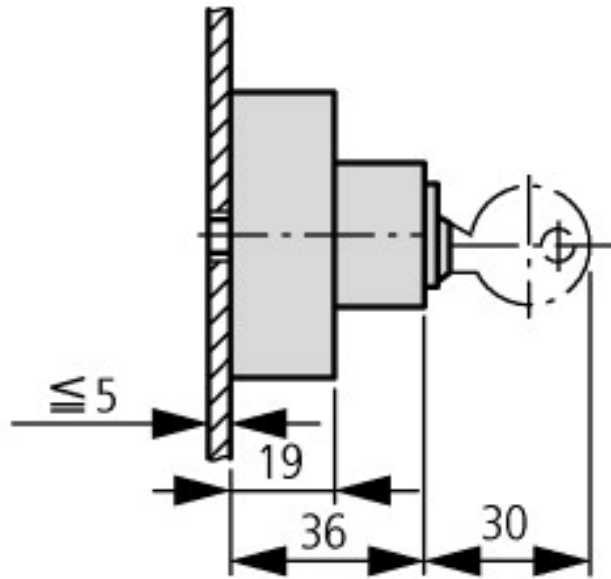
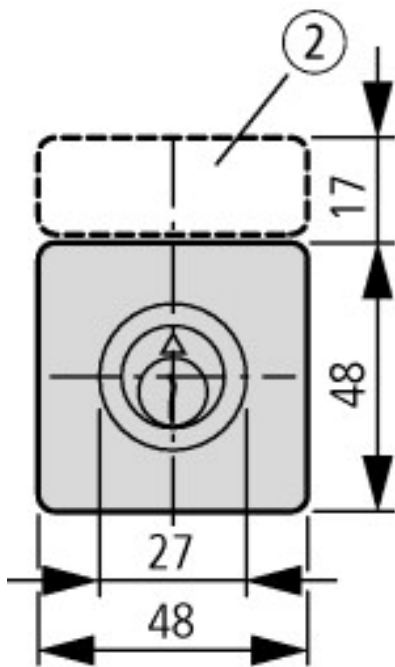

Key operation lock mechanism  
T0.../E + S-(SOND-)T0

### Additional product information (links)

**IL03801020Z (AWA1150-0586) Cam switch: Mounting**

IL03801020Z (AWA1150-0586) Cam  
switch: Mounting

[ftp://ftp.moeller.net/DOCUMENTATION/AWA\\_INSTRUCTIONS/IL03801020Z2011\\_06.pdf](ftp://ftp.moeller.net/DOCUMENTATION/AWA_INSTRUCTIONS/IL03801020Z2011_06.pdf)

<http://ecat.moeller.net/flip-cat/?edition=HPLEN&startpage=4.87>

<http://ecat.moeller.net/flip-cat/?edition=K115A&startpage=44>