

S8VK POWER SUPPLIES

Reliable and easy operation - worldwide



- » The most compact class on the market
- » Resistant in tough environments
- » Easy and fast installation

Compact power supplies...

Omron has developed a new and exciting family of compact power supplies. With the same high quality and practical design that made our previous series safe, reliable, and easy to install, the new S8VK series is even tougher, more compact and easier to use. Omron is a world leader in the development and manufacture of industrial power supplies. We launched our first compact product, the S82K, in 1987 and our S8VS compact series has been an automatic choice with customers since 2002.

To ensure that we provide the perfect solution to match every customer's need, Omron has launched 3 different families: the cost effective S8VK-C, the standard S8VK-G/T, and the top of the range S8VK-R (redundancy unit).



...that make a world of difference!



Three compelling reasons why the S8VK is the right power supply for you:

Resistant in tough environments

Omron is confident that the quality of the S8VK will exceed your high expectations. Its robust design and construction withstand harsh environments and provide stable operation over a wide operating temperature range. Because of high MTBF figures, your S8VK will keep running in stable condition for a long term.

Easy and fast installation

The S8VK series not only offers you greater flexibility when designing your machine, it also saves you time and reduces costs thanks to the minimal wiring requirements and easy one-handed mounting provided by the enhanced DIN-rail mounting clip.

The most compact class on the market

Designed with space saving in mind, the S8VK series is our most compact power-supply range ever and the most compact class on today's market.

Resistant in tough environments

Wherever the S8VK is installed within the range of the S8VK derating curve, it will give the same reliable performance for the duration of its service life. The wide operating temperature range of between -40 to 70°C guarantees stable operation in any environment where other power supplies may be found lacking. But its robust design advantages don't end there because the S8VK also offers high resistance to the vibration transmitted by machinery in close proximity, this is due to the vibration-resistant DIN-rail mounting clip.

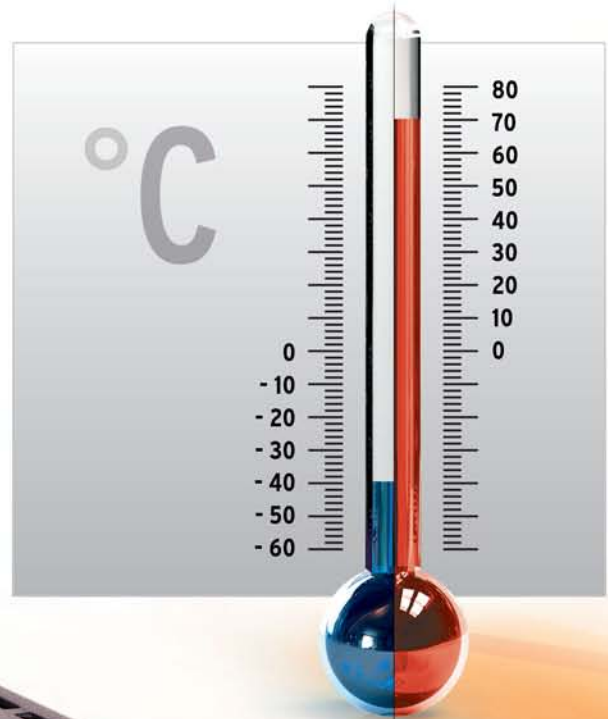

The image is for illustration purposes only.

Easy and fast installation

Making your life easier

Simply click onto a standard DIN rail using one hand to mount in a flash. Effortless and time saving! In addition, the S8VK features a double set of DC output terminals (three for the negative terminal), which means you also spend less time and effort on wiring.



Long-life guaranteed

Designed to international safety standards for global markets, the S8VK even has approvals for marine applications and carries an across-the-board, warranty on all models no matter which country your machine is exported to! Because of high MTBF figures, your S8VK will keep running in stable condition for a long term.

The most compact class on the market

Designed with downsizing in mind

Omron knows that size is important for machine designers, which is why we have applied our developed technology using thermal simulation for the design of the S8VK. This enabled the S8VK compact size body. This gives a high power density in a compact package. And the S8VK has an even sleeker exterior than any previous models.

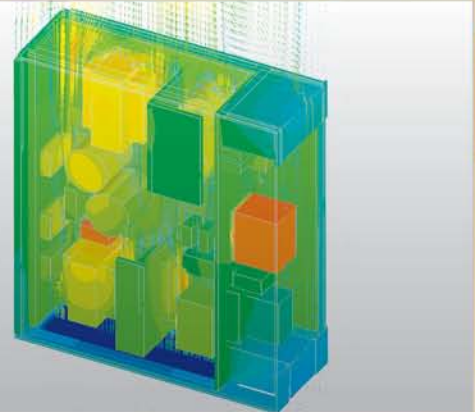

Thermal view

Component view

The S8VK series line up

The perfect match for your needs

To ensure that we have the perfect solution to match every need, Omron offers three different families:

- The cost effective S8VK-C line with uncompromising quality.
- The standard S8VK-G, our “install & forget” option, offering longer lifetime, higher protection and more features.
- The top of the range S8VK-R (redundancy unit) designed for specific applications and special demands.

Featuring	S8VK-C	S8VK-G	S8VK-R
CE & Safety standard	CE, EN60950-1 EN50178, cULus, cURus		For high reliability redundancy system Features 1. Redundancy OK LED 2. Voltage balance supporter LED 3. Signal output for the status confirmation.
INPUT	100-240VAC, 90-350VDC		
Operation Temperature	-25 to 60 °C	-40 to 70 °C	
EMI	EN55011 Class A	EN55011 Class B	
EN 61000-3-2	Yes(240/480w)	Yes	
Parallel Operation	No	Yes	
Following Standards	No	Safety transformer, EN561558-2-16, EN60204-1 PELV, Lloyd's standards	
Additional features	No	Power Boost 120%	



Ordering information

S8VK-G series

Type	Power ratings	Input voltage	Output voltage	Output current	Size (W × H × D) [mm]	Order code
Power supply Single phase	15 W	100 to 240 VAC, 90 to 350 VDC	5 V	3 A	22.5 × 90 × 90	S8VK-G01505
			12 V	1.2 A		S8VK-G01512
			24 V	0.65 A		S8VK-G01524
	30 W		5 V	5 A	32 × 90 × 90	S8VK-G03005
			12 V	2.5 A		S8VK-G03012
			24 V	1.3 A		S8VK-G03024
	60 W		12 V	4.5 A	32 × 90 × 110	S8VK-G06012
			24 V	2.5 A		S8VK-G06024
	120 W		24 V	5 A	40 × 125 × 112.2	S8VK-G12024
			24 V	10 A		60 × 125 × 140
	240 W		48 V	5 A	60 × 125 × 140	
			24 V	20 A		95 × 125 × 140
	480 W		48 V	10 A	95 × 125 × 140	

S8VK-C series

Type	Power ratings	Input voltage	Output voltage	Output current	Size (W × H × D) [mm]	Order code	
Power supply Single phase	60 W	100 to 240 VAC	24 V	2.5 A	32 × 90 × 110	S8VK-C06024	
	120 W		24 V	5 A	40 × 125 × 112.2	S8VK-C12024	
	240 W		Allowable range: 85 to 264 VAC, 90 to 350 VDC	24 V	10 A	60 × 125 × 140	S8VK-C24024
	480 W			24 V	20 A	95 × 125 × 140	S8VK-C48024

S8VK-R series

Type	Input voltage	Output current	Size (W × H × D) [mm]	Order code
Redundancy Module	5 to 24 VDC	10 A	32 × 90 × 110	S8VK-R10
	12 to 48 VDC	20 A	40 × 125 × 112.2	S8VK-R20

Specifications

S8VK-G series

Type	S8VK-G							
Item	Power ratings	15 W			30 W			
	Output voltage	5 V	12 V	24 V	5 V	12 V	24 V	
Efficiency (Typical)	230 VAC input	77%	77%	80%	79%	82%	86%	
Input	Voltage *1	100 to 240 VAC, 90 to 350 VDC (allowable range: 85 to 264 VAC) *6						
	Frequency *1	50/60 Hz (47 to 450 Hz)						
	Current (Typical)	115 VAC input	0.32 A	0.3 A	0.31 A	0.5 A	0.57 A	0.58 A
		230 VAC input	0.2 A	0.21 A	0.2 A	0.32 A	0.37 A	0.36 A
	Power factor (Typical)	0.42			0.43			
	Harmonic current emissions	Conforms to EN61000-3-2						
	Leakage current (Typical)	115 VAC input	0.14 mA			0.13 mA		
230 VAC input		0.25 mA			0.24 mA			
Inrush current (Typical) *2	115 VAC input	16 A						
	230 VAC input	32 A						
Output	Voltage adjustment range *3	-10% to 15% (with V.ADJ) (guaranteed)						
	Ripple *4	at 20 MHz (Typical)		60 mV	50 mV	30 mV	30 mV	
	Input variation influence	0.5% max. (at 85 to 264 VAC input, 100% load)						
	Load variation Influence (Rated Input voltage)	3.0% max. (5 V), 2.0% max. (12 V), 1.5% max. (24 V), at 0 to 100% load						
	Temperature variation influence	0.05%/°C max.						
	Start up time (Typical) *2	115 VAC input	530 ms	520 ms	580 ms	550 ms	550 ms	600 ms
		230 VAC input	330 ms	400 ms	400 ms	430 ms	490 ms	480 ms
Hold time (Typical) *2	115 VAC input	28 ms	29 ms	32 ms	33 ms	36 ms	23 ms	
	230 VAC input	134 ms	138 ms	134 ms	177 ms	170 ms	154 ms	
Additional functions	Overload protection *2	121 to 160% of rated current (130% typ value)						
	Overvoltage protection *2	Yes *5						
	Power Boost	120% of rated current (Refer to Engineering Data)						
	Parallel operation	Yes (Refer to Engineering Data)						
	Series operation	Possible for up to two Power Supplies (with external diode)						

*1. Do not use an inverter output for the Power Supply. Inverters with an output frequency of 50/60 Hz are available, but the rise in the internal temperature of the Power Supply may result in ignition or burning.

*2. For a cold start at 25°C. Refer to S8VK-G Datasheet (Cat. No. T056).

*3. If the output voltage adjuster (V. ADJ) is turned, the voltage will increase by more than +15% of the voltage adjustment range. When adjusting the output voltage, confirm the actual output voltage from the Power Supply and be sure that the load is not damaged.

*4. A characteristic when the ambient operating temperature is between -25 to 70°C.

*5. To reset the protection, turn OFF the input power for three minutes or longer and then turn it back ON.

*6. 90 to 350 VDC's UL standards are scheduled to obtain certification in June, 2013.

Type		S8VK-G																	
		Power ratings		60 W	120 W	240 W	480 W												
Item		Output voltage		12 V	24 V	24 V	24 V	48 V	24 V	48 V									
Efficiency (Typical)		230 VAC input		85%	88%	89%	92%	93%											
Input		Voltage *1		100 to 240 VAC, 90 to 350 VDC (allowable range: 85 to 264 VAC) *6															
		Frequency *1		50/60 Hz (47 to 450 Hz)			50/60 Hz (47 to 63 Hz)												
		Current (Typical)		115 VAC input		230 VAC input		1.0 A		1.1 A	1.3 A	2.4 A	4.7 A						
				0.6 A		0.7 A		0.7 A		1.3 A		2.3 A							
		Power factor (Typical)		0.46		0.45		0.94		0.9		0.97							
		Harmonic current emissions		Conforms to EN61000-3-2															
		Leakage current (Typical)		115 VAC input		230 VAC input		0.16 mA		0.24 mA		0.23 mA		0.30 mA					
				0.30 mA				0.38 mA		0.33 mA		0.49 mA							
		Inrush current (Typical) *2		115 VAC input		230 VAC input		16 A		16 A		16 A		32 A					
				32 A		32 A		32 A		32 A		32 A							
Output		Voltage adjustment range *3		-10% to 15% (with V.ADJ) (guaranteed)															
		Ripple *4 at 20 MHz (Typical)		150 mV		50 mV		150 mV		180 mV		350 mV		230 mV		470 mV			
		Input variation influence		0.5% max. (at 85 to 264 VAC input, 100% load)															
		Load variation Influence (Rated Input voltage)		2.0% max. (12 V), 1.5% max. (24 V), at 0 to 100% load				1.5% max. (24 V, 48 V), at 0 to 100% load											
		Temperature variation influence		0.05%/°C max.															
		Start up time (Typical) *2		115 VAC input		230 VAC input		570 ms		650 ms		790 ms		250 ms		290 ms		380 ms	
				430 ms		500 ms		750 ms		250 ms		290 ms		260 ms					
		Hold time (Typical) *2		115 VAC input		230 VAC input		26 ms		25 ms		42 ms		44 ms		43 ms		40 ms	
				139 ms		129 ms		42 ms		44 ms		44 ms		44 ms		50 ms			
Additional functions		Overload protection *2		121 to 160% of rated current, (130% typ value)			121 to 160% of rated load current, (125% typ value)		121 to 160% of rated load current, (130% typ value)										
		Overvoltage protection *2		Yes *5															
		Power Boost		120% of rated current (Refer to Engineering Data)															
		Parallel operation		Yes (Refer to Engineering Data)															
		Series operation		Possible for up to two Power Supplies (with external diode)															

*1. Do not use an inverter output for the Power Supply. Inverters with an output frequency of 50/60 Hz are available, but the rise in the internal temperature of the Power Supply may result in ignition or burning.

*2. For a cold start at 25°C. Refer to S8VK-G Datasheet (Cat. No. T056).

*3. If the output voltage adjuster (V. ADJ) is turned, the voltage will increase by more than +15% of the voltage adjustment range. When adjusting the output voltage, confirm the actual output voltage from the Power Supply and be sure that the load is not damaged.

*4. A characteristic when the ambient operating temperature is between -25 to 70°C.

*5. To reset the protection, turn OFF the input power for three minutes or longer and then turn it back ON.

*6. 90 to 350 VDC's UL standards are scheduled to obtain certification in June, 2013.

S8VK-C series

Type		S8VK-C			
Efficiency (Ave)		87%			
Input		Rated Input Voltage		100 to 240 VAC	
		Allowable range		85 to 264 VAC, 90 to 350 VDC	
		Inrush current at 230 VAC		40 A max	
Output		Voltage adjustment range		-10% to 15% (with V.ADJ)	
Additional functions		Overload protection		Yes	
		Overvoltage protection		Yes	
Others		Operating ambient temperature		-25 to 60°C	
		Storage temperature		-25 to 65°C	
		Output indicator		Yes	
		EMI		Conforms to EN61204-3, EN55011 Class A	
		EMS		Conforms to EN61204-3 high severity levels	
		Approved Standards		UL: UL508 (Listing), UL60950-1, cUL: CSA C22.2 No.107.1 and No.60950-1, EN/VDE: EN50178 (=VDE0160), EN60950-1 (=VDE0805)	
		Degree of protection		IP20 by EN/IEC60529	

S8VK-R Series (Redundancy Units)

Type	S8VK-R10	S8VK-R20
Rated Input Voltage	5 to 24 VDC	12 to 48 VDC
Output Current	10 A	20 A
Voltage Drop	0.6 V max at 10 A	0.9 V max at 20 A
Operation Temperature range	-40 to 70°C	-40 to 70°C
Safety Standard	UL60950-1, UL508, cURus, cULus, EN50178, EN60950-1	
Signal output (Only one)	30 VDC 50 mA max by Photo MOS Relay	
Redundancy OK Display	Yes	
Balance support Display	Yes	
Grounding terminal	- Yes, One for Chassis grounding	

Specifications

S8VK-G Series

Derating Curve

15, 30, 240 W (S8VK-G015 □□, S8VK-G030 □□, S8VK-G240 □□)

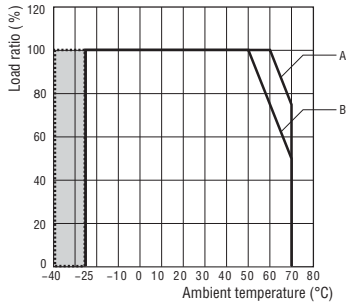

- Note:**
- At less than 90 VAC, the derating is 2.5%/V
 - For a DC power input, reduce the load given in the above derating curve by multiplying the following coefficients.
 S8VK-G015 □□: 1.0
 S8VK-G030 □□: 0.9
 S8VK-G240 □□: 0.8
 - See “-40°C Operation Guarantee Condition”
- A.** Standard mounting
60°C and over: the derating is 2.5%/°C
- B.** Face-up mounting / Side mounting (15W only)
50°C and over: the derating is 2.5%/°C

120 W (S8VK-G12024)

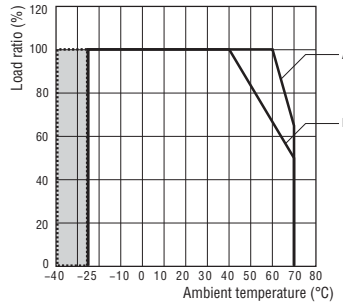

- Note:**
- At less than 90 VAC, the derating is 2.5%/V
 - For a DC power input, reduce the load given in the above derating curve by multiplying the following coefficients.
 S8VK-G12024: 0.9
 - See “-40°C Operation Guarantee Condition”
- A.** Standard mounting
60°C and over: the derating is 3.5%/°C
- B.** Face-up mounting
40°C and over: the derating is 1.67%/°C

60 W (S8VK-G060 □□)

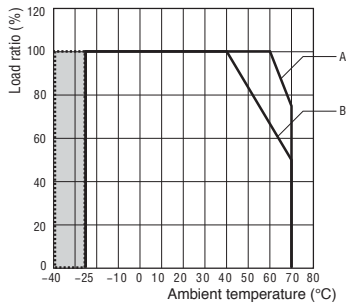

- Note:**
- At less than 90 VAC, the derating is 2.5%/V
 - For a DC power input, reduce the load given in the above derating curve by multiplying the following coefficients.
 S8VK-G060 □□: 0.9
 - See “-40°C Operation Guarantee Condition”
- A.** Standard mounting
60°C and over: the derating is 2.5%/°C
- B.** Face-up mounting
40°C and over: the derating is 1.67%/°C

480 W (S8VK-G480 □□)

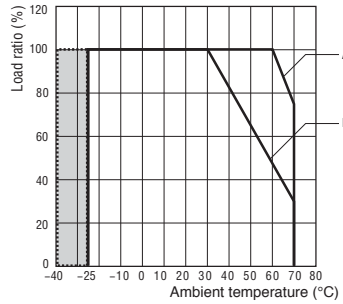

- Note:**
- At less than 90 VAC, the derating is 2.5%/V
 - For a DC power input, reduce the load given in the above derating curve by multiplying the following coefficients.
 S8VK-G480 □□: 0.8
 - See “-40°C Operation Guarantee Condition”
- A.** Standard mounting
60°C and over: the derating is 2.5%/°C
- B.** Face-up mounting
30°C and over: the derating is 1.75%/°C

-40°C Operation Guarantee Condition

The unit can start up and operate normally at -40°C, but the following criteria will be inferior to the values of datasheet. Please consider these influences.

		15 W 5 V	15 W 12 V	15 W 24 V	30 W 5 V	30 W 12 V	30 W 24 V	60 W 12 V	60 W 24 V	120 W 24 V	240 W 24 V	240 W 48 V	480 W 24 V	480 W 48 V
Ripple (Typ.)	230 VAC input	280 mV	170 mV	100 mV	110 mV	330 mV	180 mV	200 mV	420 mV	440 mV	840 mV	1220 mV	460 mV	580 mV
Ripple (Max.)	230 VAC input	830 mV	450 mV	220 mV	240 mV	630 mV	290 mV	480 mV	430 mV	450 mV	1030 mV	1320 mV	670 mV	870 mV
Start up time (Typ.)	230 VAC input	420 ms	440 ms	490 ms	410 ms	440 ms	480 ms	420 ms	490 ms	760 ms	230 ms	280 ms	260 ms	260 ms
Hold time (Typ.)	230 VAC input	88 ms	110 ms	109 ms	137 ms	112 ms	114 ms	124 ms	118 ms	20 ms	35 ms	37 ms	39 ms	41 ms

Power Boost Function

For All Models

Power Boost is a function that can output the temporary repeated boost current larger than the rated current. However, it should meet the following four Boost current conditions.

- Time that the boost current flows: t_1
- The maximum value of the boost current: I_p
- The average output current: I_{ave}
- The time ratio of the boost current flow: Duty

Note: Boost current conditions

- $t_1 \leq 10$ s
- $I_p \leq$ Rated boost current
- $I_{ave} \leq$ Rated current

$$Duty = \frac{t_1}{t_1 + t_2} \times 100 [\%] \leq 30\%$$

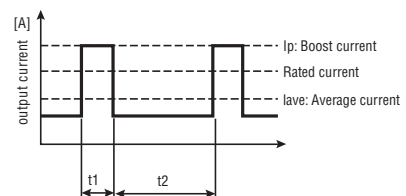

- Do not allow the boost current to continue for more than 10 seconds. Also, do not let the duty cycle exceed boost current conditions. These conditions may damage the Power supply.
- Ensure that the average current of one cycle of the boost current does not exceed the rated output current. This may damage the Power Supply.
- Lessen the load of the boost load current by adjusting the ambient temperature and the mounting direction.

S8VK-G Nomenclature

S8VK-G015 □□

S8VK-G060 □□

S8VK-G480 □□

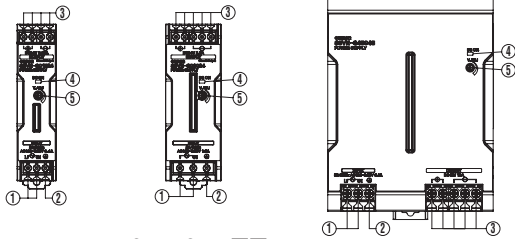

S8VK-G030 □□
S8VK-G12024
S8VK-G240 □□

No.	Name	Function
1	Input terminals (L, (N))	Connect the input lines to these terminals. *1
2	Protective Earth terminal (PE)	Connect the ground line to this terminal. *2
3	DC Output terminals (-V), (+V)	Connect the load lines to these terminals.
4	Output indicator (DC ON: Green)	Lights while a direct current (DC) output is ON.
5	Output voltage adjuster (V.ADJ)	Use to adjust the voltage.

*1. The fuse is located on the (L) side. It is not user-replaceable. For a DC input, connect the positive voltage to the L terminal.

*2. This is the protective earth terminal specified in the safety standards. Always ground this terminal.

S8VK-G Dimensions

S8VK-G015 □□

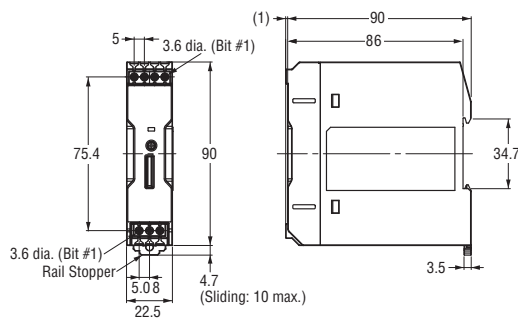

S8VK-G12024

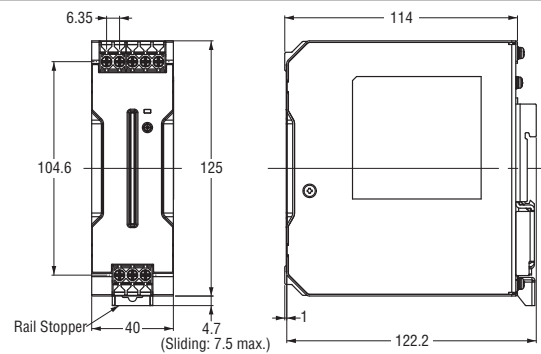

S8VK-G030 □□

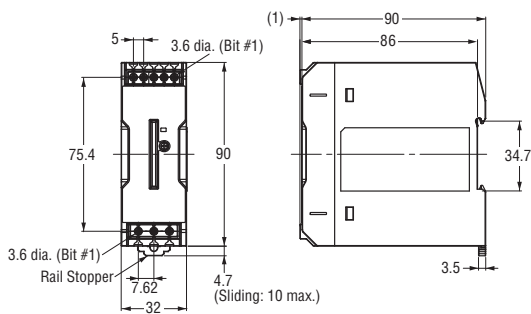

S8VK-G240 □□

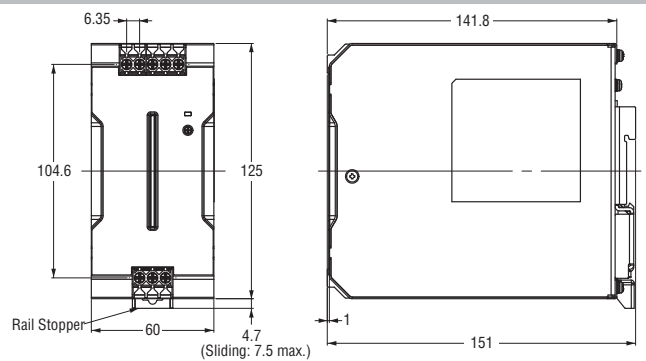

S8VK-G060 □□

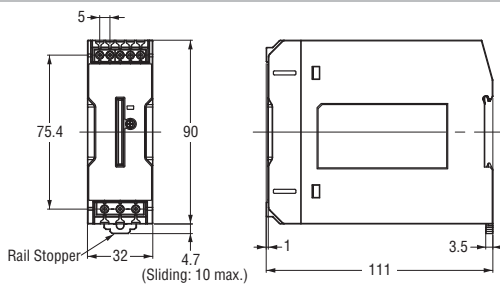

S8VK-G480 □□

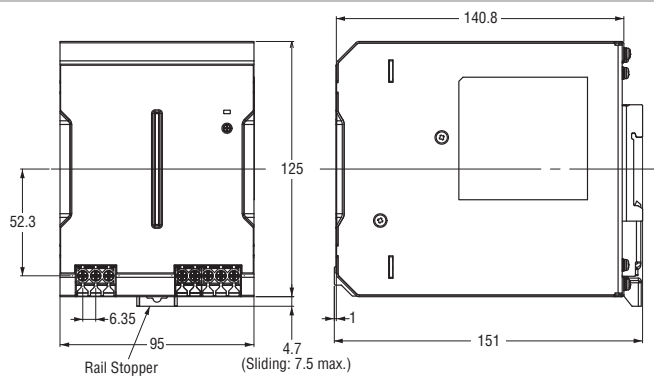

OMRON Corporation Industrial Automation Company

Tokyo, JAPAN

Contact: www.ia.omron.com

Regional Headquarters

OMRON EUROPE B.V.

Wegalaan 67-69-2132 JD Hoofddorp
The Netherlands
Tel: (31)2356-81-300/Fax: (31)2356-81-388

OMRON ELECTRONICS LLC

One Commerce Drive Schaumburg,
IL 60173-5302 U.S.A.
Tel: (1) 847-843-7900/Fax: (1) 847-843-7787

OMRON ASIA PACIFIC PTE. LTD.

No. 438A Alexandra Road # 05-05/08 (Lobby 2),
Alexandra Technopark,
Singapore 119967
Tel: (65) 6835-3011/Fax: (65) 6835-2711

OMRON (CHINA) CO., LTD.

Room 2211, Bank of China Tower,
200 Yin Cheng Zhong Road,
PuDong New Area, Shanghai, 200120, China
Tel: (86) 21-5037-2222/Fax: (86) 21-5037-2200

Authorized Distributor:

© OMRON Corporation 2013 All Rights Reserved.
In the interest of product improvement,
specifications are subject to change without notice.

CSM_1_1_0213
Cat. No. T057-E1-01

Printed in Japan
0213(0213)