

Panasonic[®]

TOUCH TERMINALS

GN Series

Hardware Manual

BEFORE BEGINNING

Liability and Copyright for the Hardware

This manual and everything described in it are copyrighted. You may not copy this manual, in whole or part, without written consent of Panasonic Electric Works Europe AG (PEWEU).

PEWEU pursues a policy of continuous improvement of the design and performance of its products. Therefore we reserve the right to change the manual/product without notice. In no event will PEWEU be liable for direct, special, incidental, or consequential damage resulting from any defect in the product or its documentation, even if advised of the possibility of such damages.

We invite your comments on this manual. Please e-mail us at:

tech-doc@eu.pewg.panasonic.com.

Please direct support matters and technical questions to your local Panasonic representative.

LIMITED WARRANTY

If physical defects caused by distribution are found, PEWEU will replace/repair the product free of charge. Exceptions include:

- When physical defects are due to different usage/treatment of the product other than described in the manual.
- When physical defects are due to defective equipment other than the distributed product.
- When physical defects are due to modifications/repairs by someone other than PEWEU.
- When physical defects are due to natural disasters.

Important Symbols

One or more of the following symbols may be used in this documentation:



DANGER!

The warning triangle indicates especially important safety instructions. If they are not adhered to, the results could be fatal or critical injury.



◆ **CAUTION**

Indicates that you should proceed with caution. Failure to do so may result in injury or significant damage to instruments or their contents, e.g. data.



◆ **NOTE**

Contains important additional information.



◆ **EXAMPLE**

Contains an illustrative example of the previous text section.



◆ **Procedure**

Indicates that a step-by-step procedure follows.



◆ **REFERENCE**

Indicates where you can find additional information on the subject at hand.

Table of Contents

1. Introduction	1
1.1 Safety Instructions	2
1.2 Overview.....	4
1.3 Electrostatic Discharge (ESD)	5
1.3.1 Grounding Methods.....	5
1.4 FCC Statement.....	6
1.5 Electromagnetic Compatibility	7
1.6 Applicable Directives and Standards	8
2. Scope of Delivery	9
2.1 Product Parts.....	10
2.2 Type Label and Product Identification	11
3. Product Description	13
3.1 All Views	14
3.2 Front View.....	16
3.2.1 USB Interface on the Front	16
3.2.2 Front Plates.....	17
3.2.3 Display with Touch Screen.....	17
3.2.4 Calibrating the Touch Screen.....	17
3.2.4.1 Calibration under Windows® CE	18
3.2.4.2 Calibration under Windows® XP.....	21
3.2.4.3 Calibration under Windows® XP Embedded	24

3.2.5	Touch Screen Care and Cleaning	25
3.3	Bottom View	26
3.3.1	Optional Interfaces	26
3.3.1.1	RS422/RS485 Serial Interface	27
3.3.2	DC Power Connector	28
3.3.3	LAN0 and LAN1 Ethernet Interface Connectors	29
3.3.4	VGA Interface Connector	29
3.3.5	Reset Button.....	29
3.3.6	Status LEDs	29
3.3.7	Grounding Screw (M4) with Lock Washers.....	30
3.4	Top View	31
3.4.1	Compact Flash Card Slot	31
3.5	Left and Right Side View	32
3.6	Rear View.....	34
3.7	Single-Board Computer.....	36
3.8	Connecting the System to the Power Supply	37
3.8.1	DC Power Plug.....	37
3.8.2	Connecting to the DC Power Supply.....	38
3.9	Mounting the System to a Subframe or Panel.....	40
3.10	Accessing Internal Components.....	43
3.10.1	Configuration of the RS422/RS485 Port	43
3.10.2	Replacing the Lithium Battery	45
4.	Technical Data.....	47
4.1	General Specifications	48
4.2	Environmental Specifications	50
4.3	Dimensions.....	51
4.3.1	Front Views	51
4.3.2	Rear and Right Side Views	53

4.4	Pin Assignments	56
4.4.1	Ethernet Interfaces (LAN0 and LAN1)	56
4.4.2	USB Interfaces	56
4.4.3	RS232 (COM1, COM2)	56
4.4.4	RS422/RS485 Configured as RS422 (4-Channel Mode)	57
4.4.5	RS422/RS485 Configured as RS485 (4-Wire Mode), Full Duplex, Bus Master	57
4.4.6	RS422/RS485 Configured as RS485 (2-Wire Mode), Half Duplex.....	57
4.4.7	VGA Port (VGA)	58
4.4.8	DC Power Connector	58
4.5	Cables.....	59
5.	Index	61

Chapter 1

Introduction

1.1 Safety Instructions



WARNING

To ensure safe operation, observe these safety instructions.

- Always take precautions to ensure the overall safety of your system so that the whole system remains safe in the event of failure of this product or other external factor.
- DO NOT USE THE PROGRAMMABLE DISPLAY TO CONTROL SAFETY FEATURES OR OTHER CRITICAL OPERATIONS OF EQUIPMENT OR SYSTEMS. A COMMUNICATION ERROR (FOR ANY REASON) MIGHT PREVENT SUCH SAFETY FEATURES OR CRITICAL OPERATIONS FROM FUNCTIONING PROPERLY.
- Do not use this product in areas with inflammable gas. It could lead to an explosion.
- Exposing this product to excessive heat or open flames could damage the lithium battery or other electronic parts.
- The on-site electrical installation must meet the requirements of the country's specific local regulations.
- If a power cable comes with the product, only this cable should be used. Do not use an extension cable to connect the product.
- To guarantee that sufficient air circulation is available to cool the product, please ensure that the ventilation openings are not covered or blocked. If a filter mat is provided, this should be cleaned regularly.
- Do not place the system close to heat sources or damp places.
- Only devices or parts which fulfill the requirements of SELV circuits (Safety Extra Low Voltage) as stipulated by IEC 60950-1 may be connected to the available interfaces.



◆ NOTE

Opening the device during the guarantee period will render the guarantee null and void.

- Before opening the device, make sure that the device is disconnected from the mains. Switching off the device by its power button does not disconnect it from the mains. Complete disconnection is only possible if the power cable is removed from the wall plug or from the device. Ensure that there is free and easy access to enable disconnection.
- If the system is expanded, you must observe the following:
 - that all effective legal regulations and all technical data are adhered to
 - the power consumption of any add-on card does not exceed the specified limitations

- the current consumption of the system does not exceed the value stated on the product label.
- Switch off and ensure that the device cannot be operated if the following apply because safe operation may no longer be possible:
 - the device has visible damages or
 - the device is no longer functioning

Additional safety instructions for DC power supply circuits

- To guarantee safe operation of devices with DC power supply voltages greater than 60V DC or a power consumption larger than 240VA, please observe that:
 - the device is set up, installed and operated in a room or enclosure marked with “RESTRICTED ACCESS” if there are no safety messages on the device itself such as safety signs or labels.
 - no cables or parts without insulation in electrical circuits with dangerous voltage or power should be touched directly or indirectly
 - a reliable protective earthing connection is provided
 - a suitable, easily accessible disconnecting device is used in the application (e.g. overcurrent protective device) if the device itself cannot be disconnected
 - a disconnect device, if provided in or as part of the equipment, shall disconnect both poles simultaneously
 - interconnecting power circuits of different devices cause no electrical hazards
- A sufficient dimensioning of the power cable wires must be selected – according to the maximum electrical specifications on the product label – as stipulated by EN60950-1 or EN60204 or UL508 regulations.
- The devices do not generally fulfill the requirements for “centralized DC power systems” (UL 60950-1, Annex NAB; D2) and therefore may not be connected to such devices!

1.2 Overview

The GN series touch panels are human-machine interfaces (HMIs) designed for demanding industrial applications such as installation in an instrument panel or switching cabinet.



◆ NOTE

All versions are suitable for installation in an instrument panel or switching cabinet. Use the mounting clamps included with the product.

The GN series includes:

- GN07, 7" display
- GN10, 10.4" display
- GN12, 12.1" display
- GN15, 15" display

In front of the display there is a touch screen that also protects the display surface from dirt and scratches. The system is suitable for operation in harsh industrial environments.

The GN is equipped with interfaces such as 1x serial COM1 (RS232), 2x LAN (10/100/1000 Mbps), 2x USB (2.0), 1x VGA. Additional interfaces can be installed as follows:

- The GN10/GN12/GN15 can be expanded with up to two different modules for RS422/485 industrial fieldbus interfaces and/or an additional serial port COM2 as RS232.
- The GN07 can be expanded with one module for the RS422/485 or an industrial fieldbus interface or an additional serial port COM2 as RS232.

The GN is designed to be connected to a +24V DC power supply using the DC power plug (included).



◆ NOTE

The GN series touch panels are designed to fulfill the IP65 degree of protection for the front side. However, the USB connector on the front (if present) must be covered by the elastic captive rubber coat.

The GN is a fanless system. The cooling of the unit is performed by ventilation holes in the housing. The ventilation holes are located at the sides of the device and provide air circulation in order to prevent the system from overheating.



◆ NOTE

When powering on the GN, make sure that the ventilation holes are not obstructed.

1.3 Electrostatic Discharge (ESD)

A sudden discharge of electrostatic electricity can destroy static-sensitive devices or micro-circuitry. Proper packaging and grounding techniques are necessary prerequisites for avoiding damage. Always take the following precautions:

- Transport printed circuit boards in static-safe containers such as boxes or bags.
- Keep electrostatic sensitive parts in their containers until they arrive at a static-free station.
- Always be properly grounded when touching a sensitive printed-circuit board, component, or assembly.
- Store electrostatic-sensitive printed-circuit boards in protective packaging or on conductive foam.

1.3.1 Grounding Methods

Guard against electrostatic damage of the device by taking the following preventative steps:

- Cover workstations with approved anti-static material. Provide a wrist strap connected to a work surface and properly grounded tools and equipment.
- Use anti-static mats, heel straps, or air ionizers for added protection.
- Handle electrostatic-sensitive components, PCBs, and assemblies by the case or the edge of the board.
- Avoid contact with pins, leads, or circuitry.
- Turn off power and input signals before inserting and removing connectors or test equipment.
- Keep the work area free of non-conductive materials such as ordinary plastic assembly aids and Styrofoam.
- Use field service tools, such as cutters, screwdrivers, and vacuum cleaners that are conductive.
- Always lay drives and PCBs with the component-side down on the foam.

1.4 FCC Statement

This equipment has been tested and found to comply with the limits for a Class A digital device, pursuant to Part 15 of the FCC Rules. These limits are designed to provide reasonable protection against harmful interference when the equipment is operated in commercial environment. This equipment generates, uses, and can radiate radio frequency energy and, if not installed and used in accordance with the instruction manual, may cause harmful interference to radio communications. Operation of this equipment in residential area is likely to cause harmful interference in which case the user will be required to correct the interference at his own expense. This Class A digital apparatus complies with the Canadian ICES-003.

1.5 Electromagnetic Compatibility

This product has been designed for industrial use. The most recent version of the EMC guidelines (EMC Directive 2004/108/EC) and national laws apply. If the user modifies and/or adds to the equipment (e.g. installation of add-on cards), the prerequisites for the CE conformity declaration (safety requirements) may no longer apply.

1.6 Applicable Directives and Standards

Applicable directives for the CE mark	
Low Voltage Directive (Electrical Safety)	2006/95/EC
EMC Directive	2004/108/EC

Electrical safety	Standards
EUROPE	EN 60950-1: 2006
USA / Canada	UL 60950-1: 2006 cULus Listed
CB Scheme	CB Certification





EMC	Standards
EN 61000-3-2:2006	Limits - Limits for harmonic current emissions (equipment input current \leq 16 A per phase)
EN 61000-3-3:2006	Limitation of voltage changes, voltage fluctuations and flicker in public low-voltage supply systems, for equipment with rated current \leq 16 A per phase and not subjected to conditional connection
EUROPE	Generic standards - Emission standard for residential, commercial and light-industrial environments (Emission): EN 61000-6-3: 2007 Emission of Information technology equipment – Radio disturbance characteristics – Limits and methods of measurement EN 55022/B: 2006 Generic standards - Immunity for industrial environments (Immunity): EN 61000-6-2: 2005
U.S.A. Canada	FCC 47 CFR Part 15, Class A ICES-003

Chapter 2

Scope of Delivery

2.1 Product Parts

The system comes with the following parts:

Item	Description
	GN system in the configuration ordered: <ul style="list-style-type: none"> • GN07 • GN10 • GN12 • GN15
	Phoenix power plug
	Stylus (touch pen)
	4 x mounting clamp with Allen screws for the GN07 8 x mounting clamp with Allen screws for the GN10
	6 x mounting clamp with Allen screws for the GN12 8 x mounting clamp with Allen screws for the GN15

2.2 Type Label and Product Identification

Product name	Product identification
AIGN07xxxx	GN07 (system with a 7" display)
AIGN10xxxx	GN10 (system with a 10.4" display)
AIGN12xxxx	GN12 (system with a 12.1" display)
AIGN15xxxx	GN15 (system with a 15" display)

The xxxx stands for the system configuration ordered, which depends on the application, e.g. Machine Vision. The inspection status label and the type label (product name, serial number) are located on the rear of the device.

Chapter 3

Product Description

3.1 All Views

The pictures show a GN10.



Bottom view



Right view

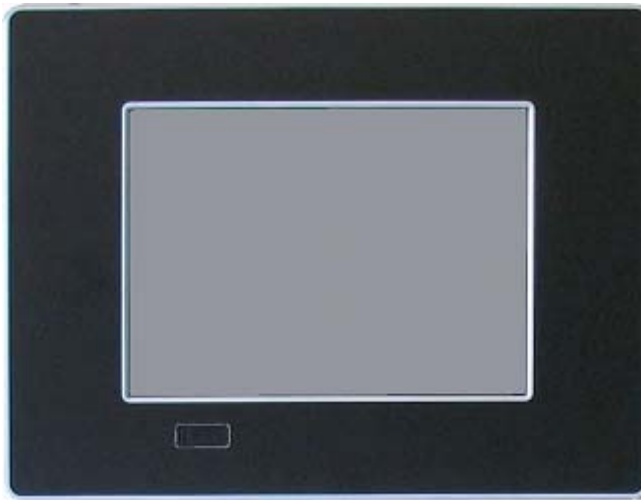

Front view



Left view



Top view

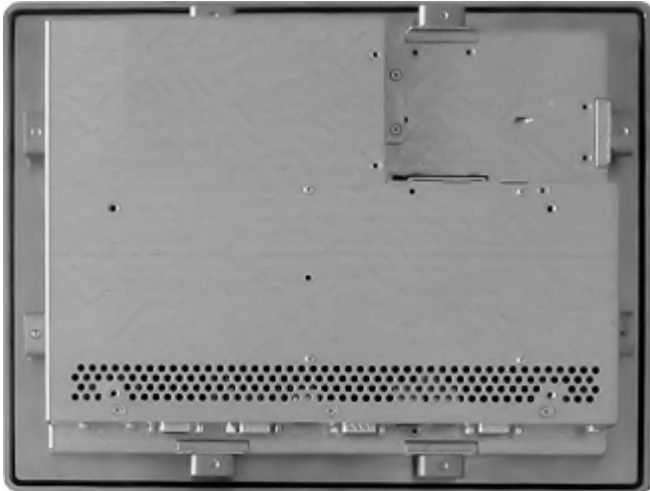

Rear view

3.2 Front View



◆ NOTE

The GN07 is not equipped with a USB interface on the front.

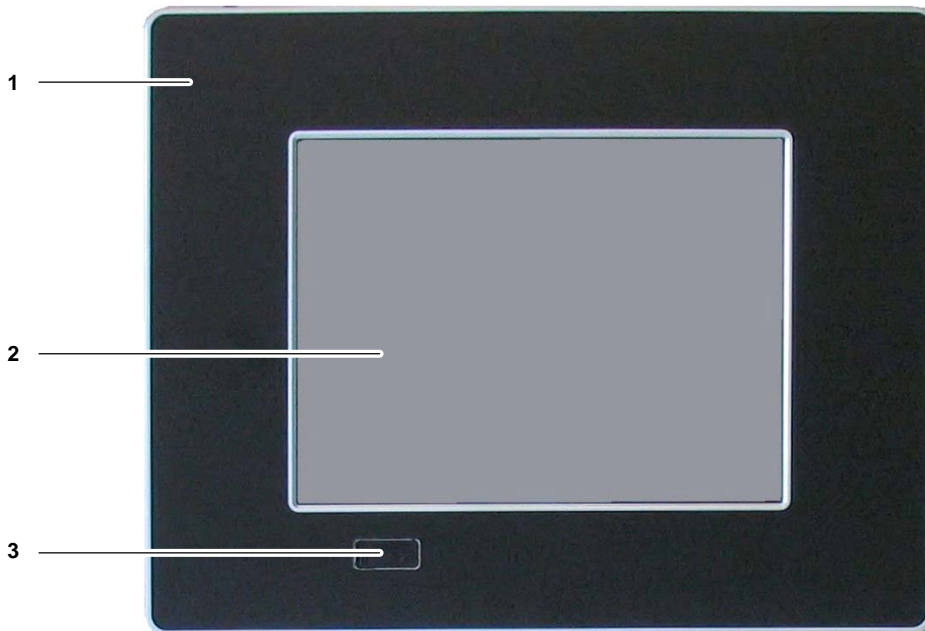

Typical front view

1	Front plate
2	TFT display with touch screen (glass-to-glass technology)
3	Covered USB interface

3.2.1 USB Interface on the Front



◆ NOTE

- The GN series touch panels are designed to fulfill the IP65 degree of protection for the front side. However, the USB connector on the front (if present) must be covered by the elastic captive rubber coat.
- The GN07 is not equipped with a USB interface on the front.

This USB 2.0 interface allows you to connect different USB-compatible devices to the GN series. The USB connector is covered by an elastic captive rubber coat. The rubber coat prevents the penetration of fluids when no device is connected.

3.2.2 Front Plates

All versions are suitable for installation in an instrument panel or switching cabinet. The material used for the front plate differs depending on the system:

- GN07: zinc-coated steel plate painted RAL9011 (black)
- Others: aluminum front plate with polyester front foil

Dimensions (mm)	GN07	GN10	GN12	GN15
Front plate (W x H)	235 x 168	348 x 277	380 x 312	449.4 x 354
Display (W x H)	157 x 95.8	214.2 x 161.2	248 x 186.5	306 x 230
Rear side enclosure (W x H x D)	215 x 146.2 x 45.7	295 x 234 x 44	324 x 263 x 49.5	406.4 x 311 x 50

3.2.3 Display with Touch Screen

GN series touch panels include a TFT display (see page 48) with corresponding resistive touch screen (glass-glass technology). A stylus is supplied for touch screen operation.

The surface of the display is also mechanically protected by the touch screen. The touch screen (USB connected) registers contacts of a finger or a pen and allows you to move the mouse pointer. This works only if the necessary software is installed. You receive the touch screen driver for your operating system installed on your system.



◆ NOTE

- **Do not use a hard or a pointed object (like screw drivers) to operate the touch screen because this can damage the touch screen surface.**
- **The front panel (GN10/GN12/GN15) and the touch screen are covered by a plastic overlay. Be careful when cleaning the plastic overlay (see page 25).**

3.2.4 Calibrating the Touch Screen

Calibration serves two purposes:

- Sets the active area of the touch screen.
- Aligns the active area of the touch screen to the screen's image.



◆ NOTE

Before you calibrate the touch screen, let the system warm up for 30 minutes.

Calibration aligns the active touch-sensitive area of the touch screen with the image on the display. Calibration also determines the edges of the screen's image and locates the center of the touch screen. If the touch screen is not calibrated properly, the active area of the touch

screen may not be aligned with the screen's image or may be unnecessarily small in size. If you need to access the calibration routine, use a USB mouse.

The touch screen of your GN system is factory calibrated. Run the calibration routine when an alignment problem exists between the mouse pointer and the stylus contact location on the screen. You can adjust the touch screen calibration with the software "Hampshire TSHARC Control Panel".

Depending on the operation system installed, the calibration procedure is slightly different.

3.2.4.1 Calibration under Windows® CE

To calibrate the system under Windows® CE, please proceed as follows:



◆ Procedure

1. Double-click the icon "hcecal.exe" on the desktop



2. Touch the calibration target to start the calibration

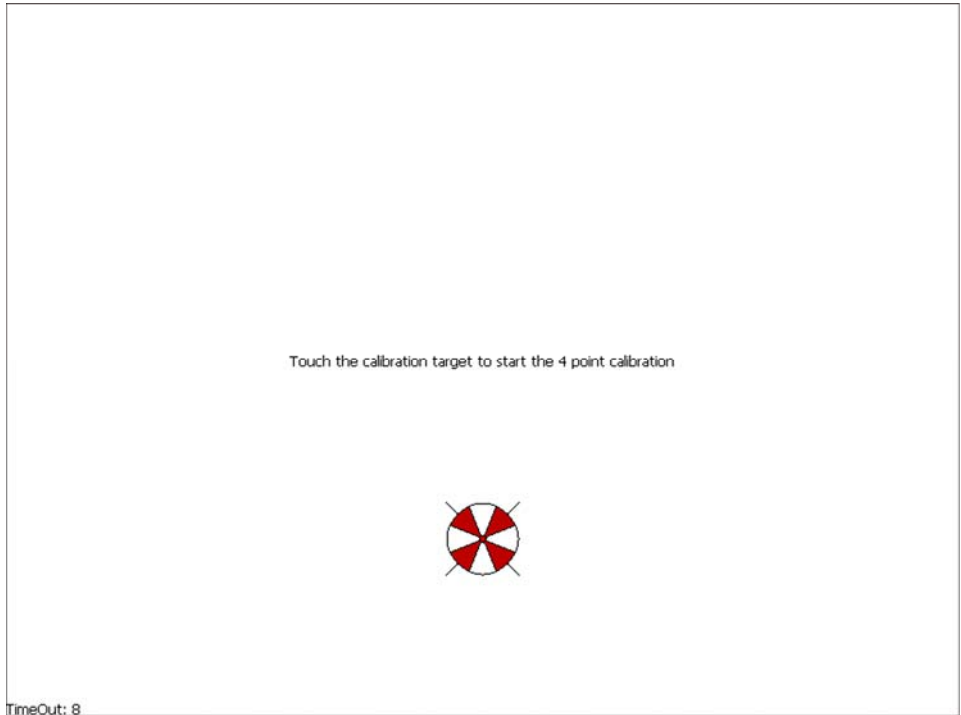

3. Touch the calibration target

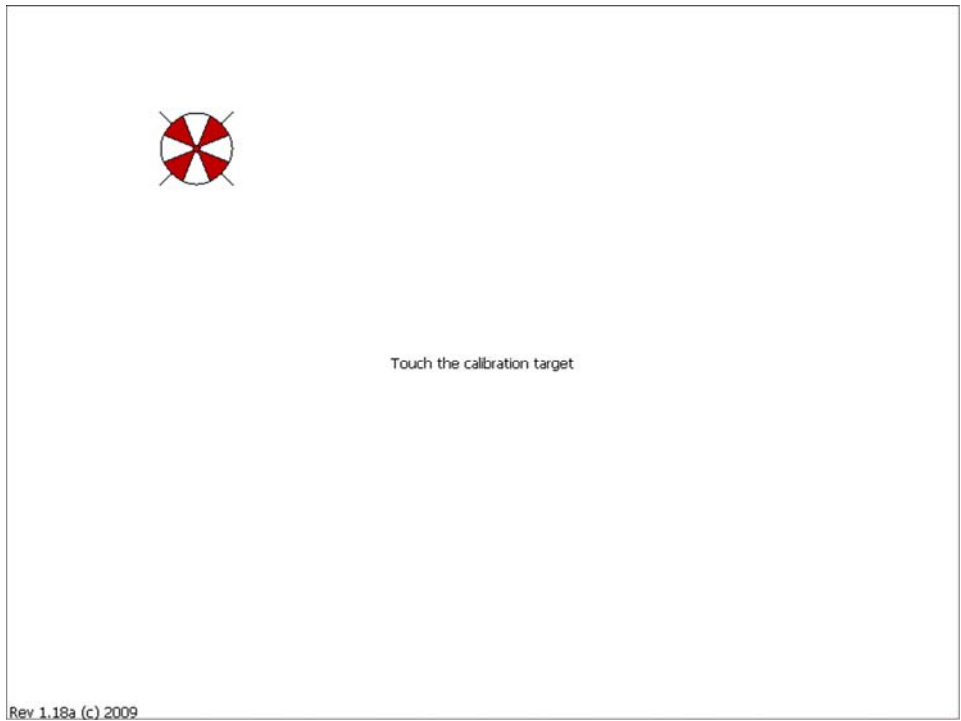

4. Touch the screen to verify that the cursor moves to your finger

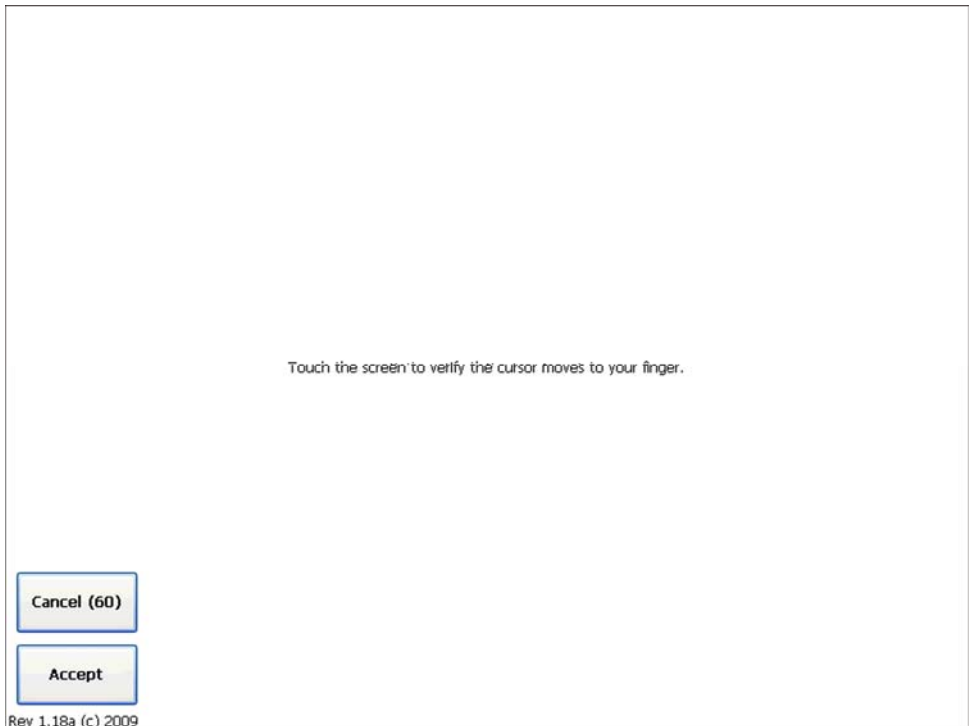

5. Double-click the icon "regsav.exe" on the desktop to save the settings in the registry



3.2.4.2 Calibration under Windows® XP

To calibrate the system under Windows® XP, please proceed as follows:



◆ Procedure

1. **Start → Programs → Hampshire TSHARC Control Panel**

The following screen will appear:



2. Select the "Calibration" tab

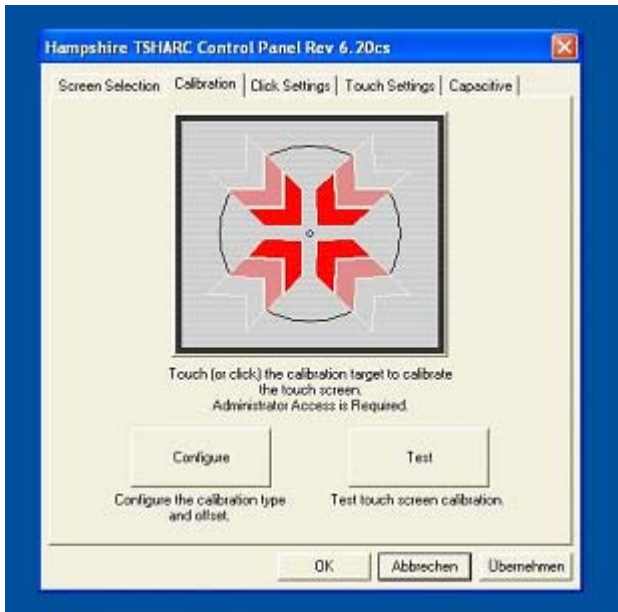

3. Select [Configure] to set up calibration

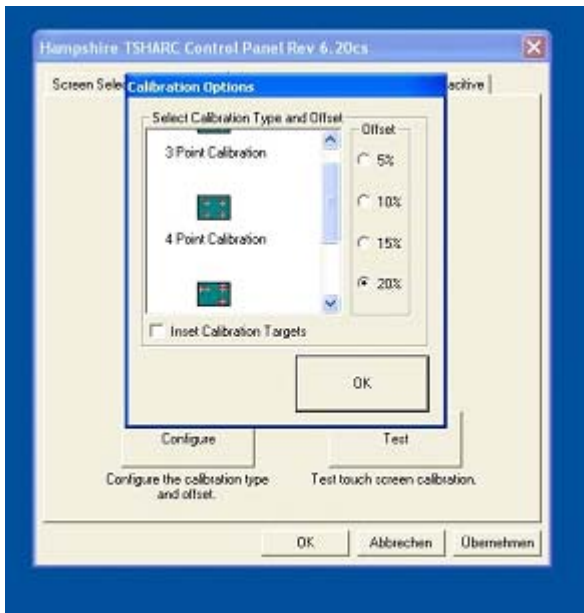

4. Select the number of calibration points and offset

5. Select [OK]

6. Select [Test]



7. When prompted, touch the panel at the location indicated

8. Select [Accept]



◆ REFERENCE

For more information about touch screen calibration, see the Hampshire® TSHARC™ UniWinDriver™ Users Manual for Windows® XP on www.hampshirecompany.com (<http://www.hampshirecompany.com>).

3.2.4.3 Calibration under Windows® XP Embedded

To calibrate the system under Windows® XP Embedded, please proceed as follows:



◆ Procedure

1. Double-click the icon "hwincal.exe" on the desktop

This starts the calibration program C:\Program Files\tsharc\hwincal.exe.

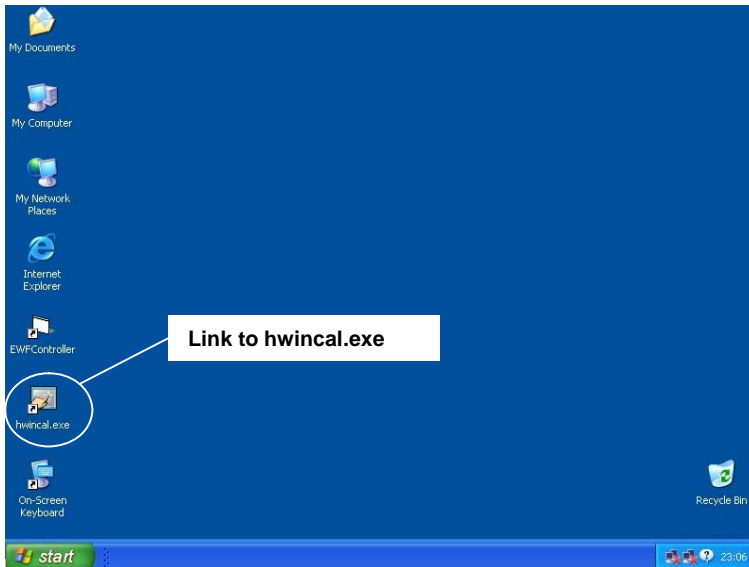

The following screen appears.

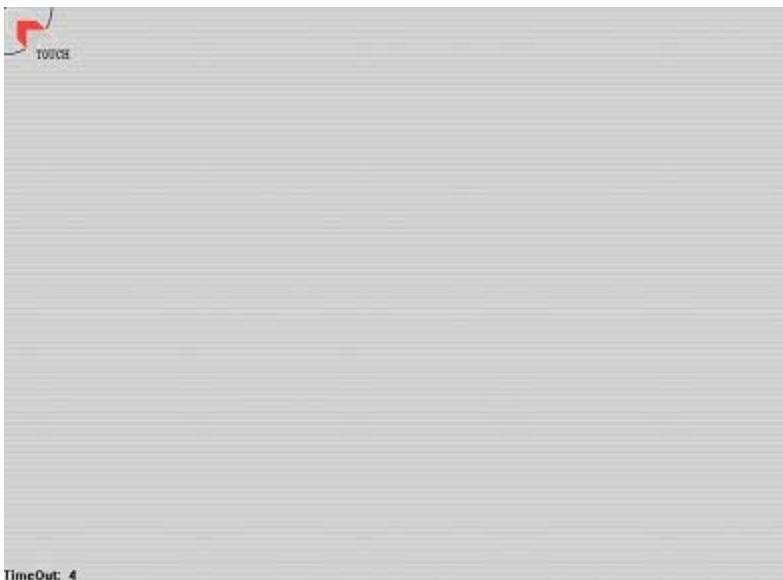

2. Touch the center of each target as accurately as possible



◆ REFERENCE

For more information about touch screen calibration, see the Hampshire® TSHARC™ UniWinDriver™ Users Manual for Windows® XP on www.hampshirecompany.com (<http://www.hampshirecompany.com>).

3.2.5 Touch Screen Care and Cleaning

For cleaning we recommend a mild detergent and water. Do not use of strong solvents, which could attack paint or plastic. Protect the plastic overlay and the touch screen surface from direct heat sources such as cigarettes. The display front is sealed against dust, liquids, etc.

The front surface of the touch screen is a flexible plastic foil. Avoid touching it with sharp objects such as a knife, a pen or a pencil tip. Sharp objects can permanently damage the functionality of the touch screen. Units without a touch screen have a polycarbonate shield, which may be scratched if an object is sufficiently sharp.

3.3 Bottom View

Bottom view of the GN10/GN12/GN15

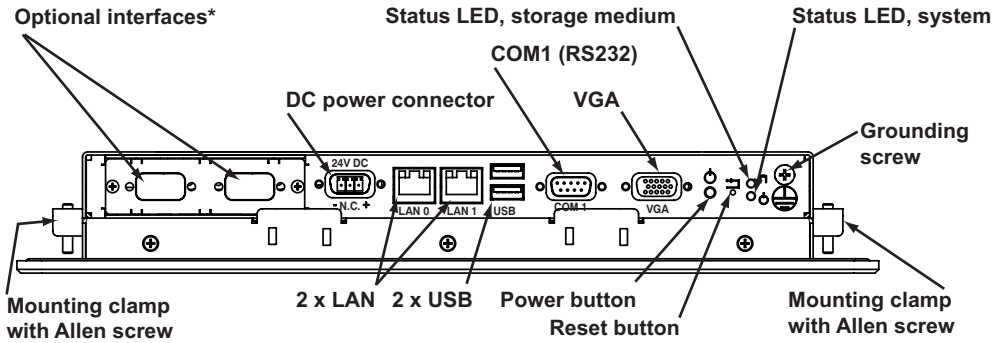

*Optional interfaces: RS422/485 (insulated), industrial fieldbus, industrial Ethernet...

Bottom view of the GN07

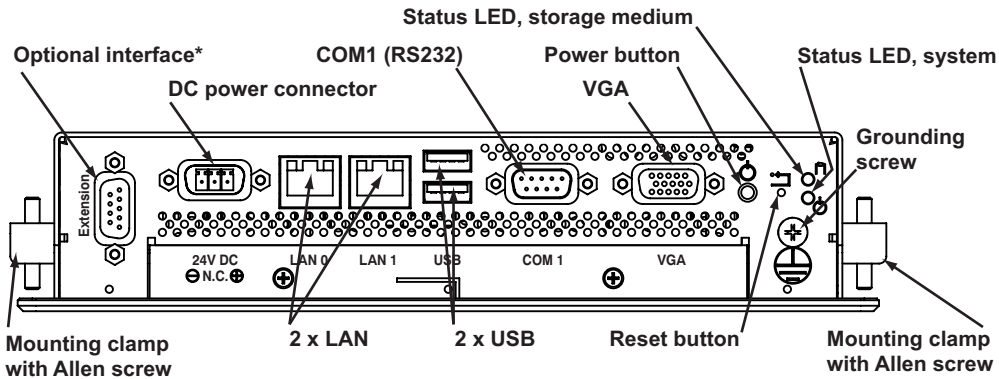

*Optional interface: RS422/485 (insulated), industrial fieldbus...

3.3.1 Optional Interfaces

Three optional interfaces are available:

- RS422/485 isolated 1.5kV (see page 27)
- Industrial fieldbus
- Industrial Ethernet (not GN07)

Depending on your requirements, GN10/GN12/GN15 supports up to two optional interfaces; GN07 supports one.

3.3.1.1 RS422/RS485 Serial Interface

The optional RS422/485 serial interface is available as a Sub-D 9-pin connector (female). The interface can be configured via DIP switches (see tables).

RS485 mode communication can be either in full-duplex or half-duplex mode. While running in RS485 half duplex mode, the system stays in receiver mode. Switching to transmission mode occurs automatically and is triggered by the RTS line or the last sent message using the TxD line, which the user defines.

- **RTS:** the RTS signal must be activated by the application software before starting the data packet transmission. The RTS signal has to be disabled again after data transmission has been terminated.
- **TxD:** the receiver device has to wait a certain time (timeout) before starting to send any data.



Default DIP switch settings

DIP switch (SW1) settings. Factory settings are marked in gray.

Serial communication type	Switch from transmitting to receiving mode	SW1 settings		
		DIP1	DIP2	DIP3
RS422 4-channel mode	-	OFF	OFF	OFF
RS485 4-wire mode (Bus Master)	-	ON	OFF	ON
RS485 2-wire mode	RTS	ON	ON	ON
RS485 2-wire mode	Timeout	ON	ON	OFF

Termination resistor for RS422 and RS485	SW1 settings
	DIP4
Deactivated	OFF
Activated	ON

Timeout	Min. baud rate	SW1 settings			
		DIP5	DIP6	DIP7	DIP8
10.2ms	1200	OFF	OFF	OFF	OFF
9.6ms		OFF	OFF	OFF	ON
9.0ms		OFF	OFF	ON	OFF
8.4ms		OFF	OFF	ON	ON
7.8ms		OFF	ON	OFF	OFF
7.2ms		OFF	ON	OFF	ON
6.5ms		OFF	ON	ON	OFF
5.9ms		OFF	ON	ON	ON
4.8ms	2400	ON	OFF	OFF	OFF
4.3ms		ON	OFF	OFF	ON
3.7ms		ON	OFF	ON	OFF
3.1ms		ON	OFF	ON	ON
2.5ms	4800	ON	ON	OFF	OFF
1.9ms		ON	ON	OFF	ON
1.2ms	9600	ON	ON	ON	OFF
0.6ms	19200	ON	ON	ON	ON

3.3.2 DC Power Connector



DC power connector

Plug in the DC power plug (see page 37) to the DC power connector to supply power to the GN unit.

3.3.3 LAN0 and LAN1 Ethernet Interface Connectors

These interface connectors are provided as RJ45 sockets with integrated LEDs.

Ethernet port	Data transfer rate
LAN0	10/100/1000 Mbps
LAN1	10/100/1000 Mbps

Ethernet LED States:

Left LED state	Link activity state	Right LED state	Link speed
Green	Link active	Off	10 Base-T
		Green	100 Base-T
		Yellow	1000 Base-T

3.3.4 VGA Interface Connector

An external (analog) monitor can be plugged into this Sub-D 15-pin socket.

3.3.5 Reset Button

To restart the GN unit e.g. after a system hang-up, press the reset button with a pen, for example. The system restarts automatically; you do not have to switch the computer off and on.



◆ NOTE

During a reset, all data in the main memory is erased.

3.3.6 Status LEDs

Status LED, storage medium (HDD/CF)

LED	Status
Green	CF activity.
Red	HDD activity.

Status LED, system

LED	Status
Green	The system is running.
Orange	The system is in standby.
Orange blinks 4 times	Battery is improperly connected. Switch the +/- pole.
Off	The system is disconnected from the power source.

**◆ NOTE**

- Use an isolating switch to turn the DC power supply on and off.
- The GN unit is only completely disconnected from the DC main power supply when the DC power cord is disconnected either from the power supply or the unit. Therefore, the DC power cord and its connectors must always remain easily accessible.

3.3.7 Grounding Screw (M4) with Lock Washers

The housing of the GN unit must be grounded by establishing a large-area contact between the grounding screw M4x19 (DIN7985) with 2 x lock washer M4 (DIN6797) and an appropriate grounding connection point. The minimum cross section of the grounding conductor is 1mm² (AWG 18).

3.4 Top View

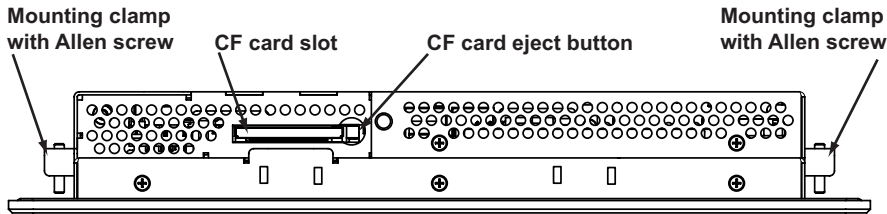

Top of the GN10/12/15

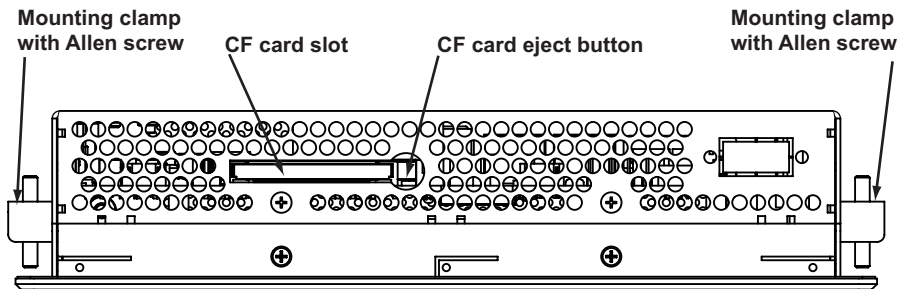

Top of the GN07



◆ NOTE

- The GN07 system does not have mounting slots on the top.
- When powering up the system, make sure that the air intake and exhaust openings are not obstructed.

3.4.1 Compact Flash Card Slot

The system is equipped with a compact flash (CF) card slot and only accepts CF cards type I.



◆ NOTE

- Before installing or removing the CF card, the GN unit must be powered down and disconnected from the power supply.
- The GN10/GN12/GN15 is equipped with an angled metal cover in order to cover the card slot if no CF card is inserted. If a CF card is inserted, the cover can be mounted in the "safe-keeping" location. The GN07 does not have an angled metal cover for the CF card slot.

3.5 Left and Right Side View

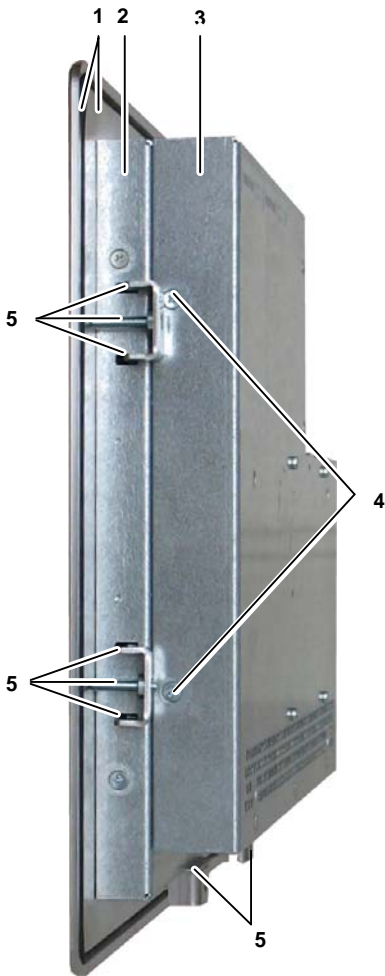

Right side of a GN10

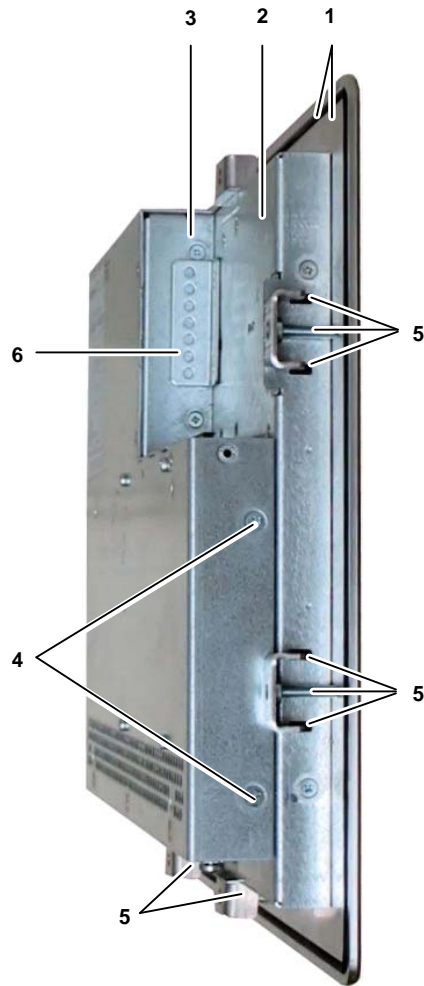

Left side of a GN10

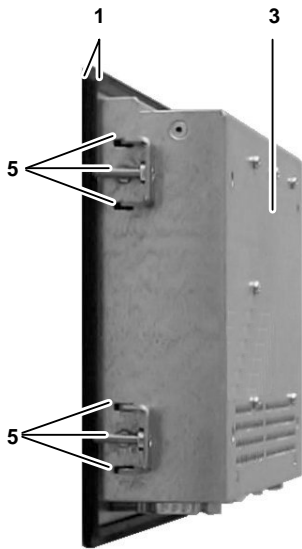

Right side of a GN07

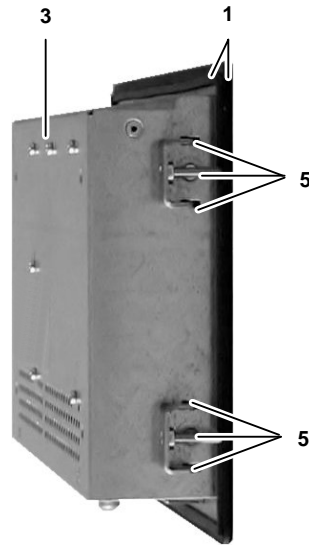

Left side of a GN07

1	Front panel of the system with seal on the rear
2	Enclosure of the display
3	System cover
4	Screws that secure the cover on the left and right side
5	Mounting slots with installed mounting clamp and Allen screw
6	"Safe-keeping" location for the angled metal cover of the CF slot if a CF card is inserted (the cover is not used for the GN07)

3.6 Rear View

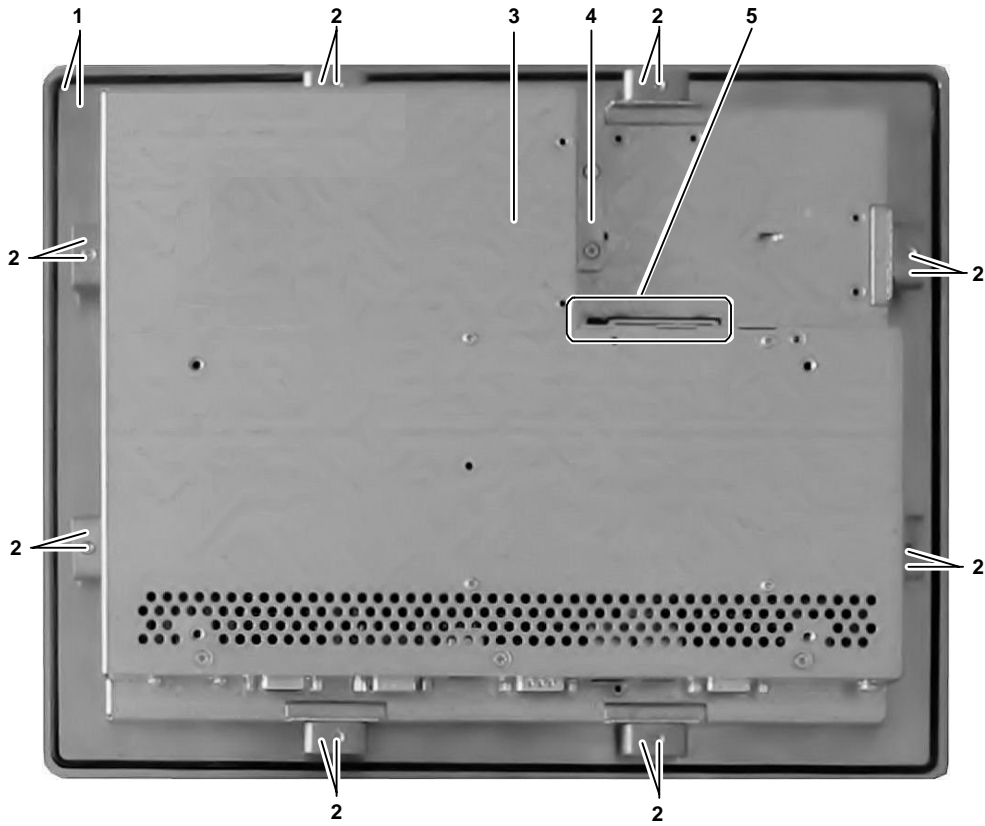

Rear of the GN10

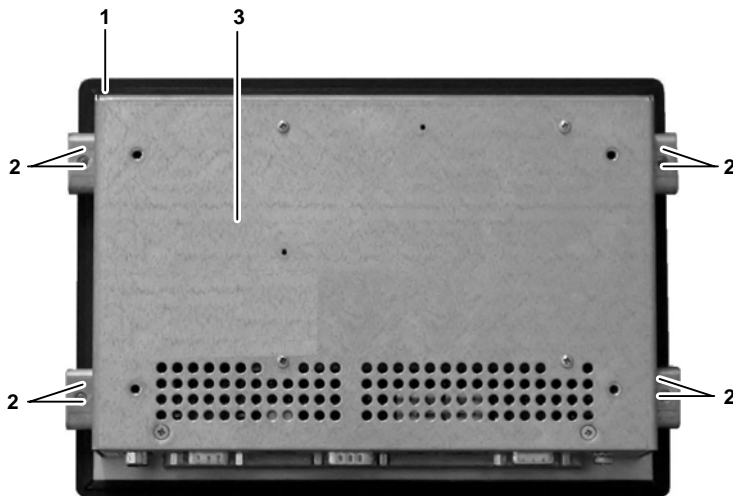

Rear of the GN07

1	Front panel of the system with seal at the rear side
2	Mounting clamp and Allen screw for mounting to a subframe
3	System cover
4	Cover for the CF card slot ("safe keeping" location, if a CF card is inserted)
5	CF card slot and CF card eject button

3.7 Single-Board Computer

The GN unit is equipped with a single-board computer based on Intel® Atom™ Processor.

3.8 Connecting the System to the Power Supply



◆ CAUTION

- Attach the power cable last!
- Before using your system, you should first become familiar with the system components and check that everything is connected properly.

3.8.1 DC Power Plug

The GN panels are delivered with a DC power plug (3-pin Phoenix connector), which you need to prepare.



◆ NOTE

The length of the wires connected to the DC power connector may not exceed 10m.

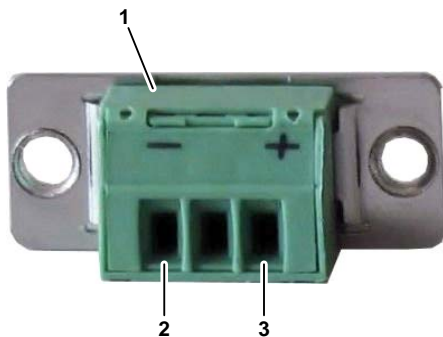

DC power plug

1	Cover for terminal screws
2	"-" wire terminal
3	"+" wire terminal



◆ Procedure

1. Cut the two isolated wires [AWG18 (\varnothing up to 1mm²)] to the required length
2. Strip each end 5 – 7mm

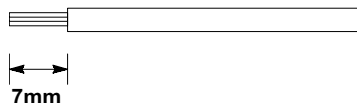

3. Apply wire end ferrules

4. Lift the cover, for example with a screwdriver, to access the terminal screws

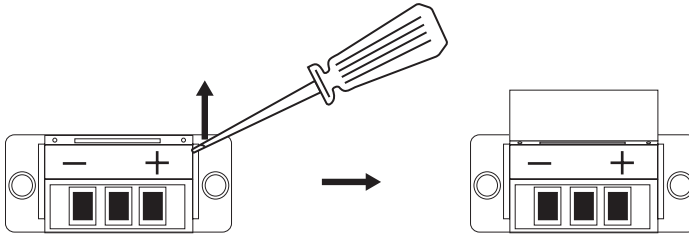

5. Turn the terminal screws counter-clockwise to loosen

6. Insert the wires into the corresponding terminals

Make sure that the polarity is correct!

7. Turn the screws clockwise to tighten

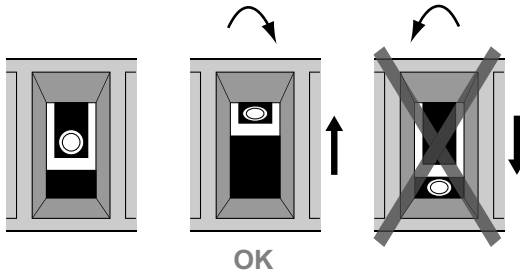

8. Close the cover

9. Prepare the other end of each wire for connection to the DC power supply

3.8.2 Connecting to the DC Power Supply

Connect the GN panel to a DC power supply using the DC power plug and a corresponding cable (see page 38).

The DC power supply must be able to output 50W to cope with the inrush current.



◆ NOTE

- The DC power supply should be able to be switched off and on via an isolating switch.

- **The unit is only completely disconnected from the DC main power supply when the DC power cord is disconnected either from the power supply or the unit. Therefore, the DC power cord and its connectors must always remain easily accessible.**

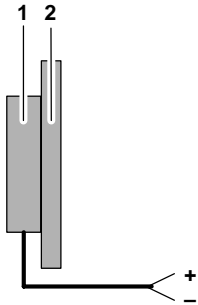

Connecting to the DC power supply

1	PC unit
2	Display



WARNING

Ensure that the DC power supply is switched off via an isolating switch in order to ensure that no power is flowing from the external power supply during the connection procedure. Otherwise, electric shock may be the result.



◆ Procedure

1. **Connect the 3-pin DC power connector of the DC power cable to the appropriate DC power connector of the GN panel.**

The DC power connector of the system is located on the rear bottom side and is labeled "-24V DC+" (see page 28). Make sure the connector is securely locked in place.

2. **Connect the other end of the DC power cable to the terminals of the 24V DC power supply**

Ensure that the power connections maintain the proper polarity.

3. **Switch on the isolating switch in order to apply voltage to the terminals of the power supply (cable wires)**

When turning on power to the system via the isolating switch, the GN panel will immediately boot the installed operating system.

3.9 Mounting the System to a Subframe or Panel

The system is delivered with mounting clamps and Allen screws in order to mount the system to a subframe or panel.

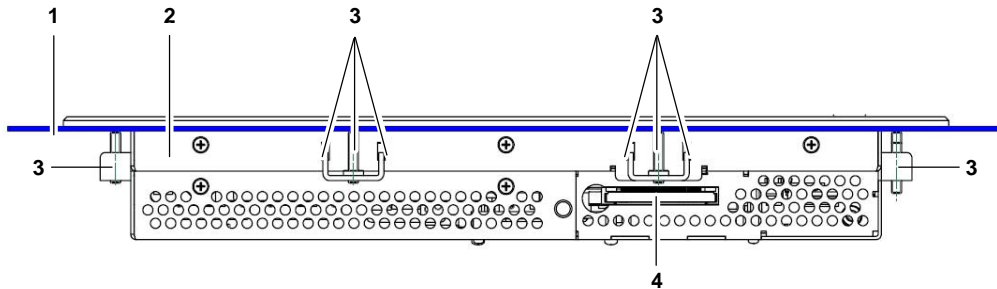

Mounting a GN10



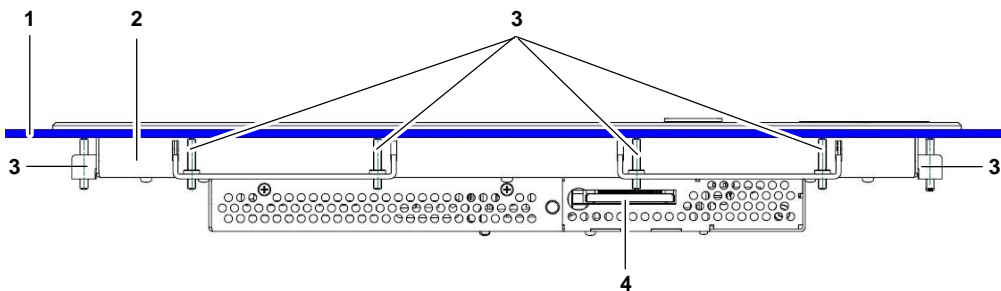

1	Example of subframe for system installation
2	Enclosure of the 10.4" display
3	Mounting clamp with screw
4	Compact flash card slot



Mounting a GN15

1	Example of subframe for system installation
2	Enclosure of the 15" display
3	Mounting clamp with screw
4	Compact flash card slot

The mounting clamps enable easy, fast mounting of the GN unit onto an instrument panel or wall panel.

Item	GN07	GN10	GN12	GN15
Rear side enclosure (W x H x D, mm)	215 x 146.3 x 45.75	295 x 234 x 44	324 x 263 x 49.5	406.4 x 311 x 50
Panel cutout (W x H, mm)	217 x 148	297 x 236	326 x 265	408 x 313
Metal mounting panel thickness (mm)	1.5 – 6	1.5 – 6	1.5 – 8	1.5 – 8
Mounting clamps with screws	4 x 	8 x 	6 x 	8 x 
Required tool	Allen wrench 2mm			
Proper torque	Tighten the screws with a torque of 0.5•Nm			
Mounting position	Ensure the vertical and horizontal alignment of the system.			



◆ NOTE

- In order to ensure IP65 front sealing against dust and water, mount the system on a non-textured surface. Before you install the GN unit on a panel or a subframe for a switching cabinet, verify that the seal on the rear of the front plate is in perfect condition. The seal has to be in place without defects and dirt.
- When you install the GN07 on a panel or a subframe for a switching cabinet, leave enough free space at the rear top side to insert or remove the CF card.

To mount the system to a subframe or to a panel, proceed as follows:



◆ Procedure

1. Assemble the mounting clamps with the Allen screws included
2. Depending on the dimension of the display enclosure of your system, cut a hole in the panel/subframe
Refer to the tables for the panel cut-out dimensions. The panel where you intend to attach the system must be accessible from both the front and the rear side. The system must be turned off and disconnected from the power supply and peripheral devices
3. Insert the system into the panel cut-out from the front
In order to ensure the protection class IP65 on the front after installation, the contact surface with the seal must be clean and flush.
4. Ensure the vertical and horizontal alignment of the system

5. **Fasten the system from the rear using the mounting clamps**
6. **Hook the mounting clamps with screws from the rear side of the panel into the corresponding pairs of slots of the enclosure**

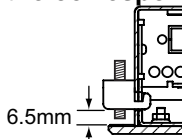

Maximum height for mounting the bracket

The system must be attached firmly with the screws. Tighten the screws with a torque of 0.5•Nm.

3.10 Accessing Internal Components



WARNING

Before removing the cover of the GN unit in order to gain access to the internal components, the system must be powered down and the power cord has to be disconnected from the power supply.

Otherwise, electric shock may be the result.

The system may only be opened in accordance with the description in this hardware manual for:

- Replacing the lithium battery
- Configuring the RS422/RS485 interface (GN10/GN12/GN15). These procedures may be carried out by qualified specialized personnel only.



◆ CAUTION

- Do not operate the system without the cover.
- Please observe the safety instructions for handling assemblies with static-sensitive devices. Failure to do so can result in damage to the device.

3.10.1 Configuration of the RS422/RS485 Port

The configuration of the RS422/RS485 port (see page 27) can be changed via the DIP switches. In order to change the factory configuration (RS422 4-channel mode), proceed as follows:



◆ NOTE

The new port configuration has to be set before the system is installed on a panel or into a switching cabinet. The system must be disconnected from the power supply. Disconnect all peripheral devices. Before you begin, ensure that you have a clean, flat and ESD-safe surface to work on.



◆ Procedure

1. Close all applications and shut down the system properly
2. Disconnect the power cord from the power supply
3. Disconnect all peripheral devices

The system should lay on a flat, clean surface with the front panel facing downwards. Make sure that the display surface is protected against scratching

and damage.

4. **GN07: Unscrew the screws that secure the cover**
GN10/12/15: Unscrew the screws that secure the metal cover on the optional interface area
5. Remove the cover and put it aside
6. Locate the DIP switches in the unit

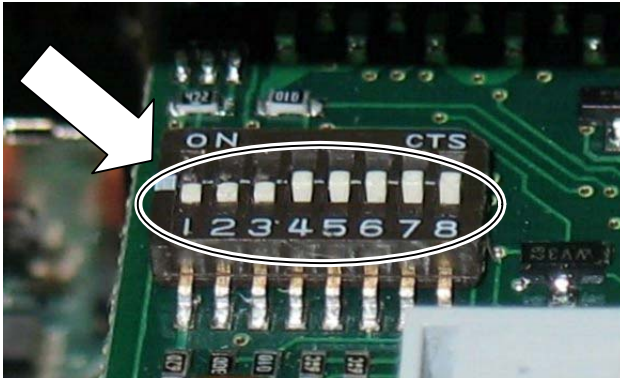

7. By use of an insulated thin tool (e. g. screwdriver or a stylus) set the DIP switches to the up (for ON) or down (for OFF) position corresponding to the port configuration required

The default port configuration is RS485 2-channel mode (see page 27) with timeout.



8. Put the cover back on
9. When the cover is firmly in place, fasten the screws

3.10.2 Replacing the Lithium Battery

The motherboard is equipped with a lithium battery.

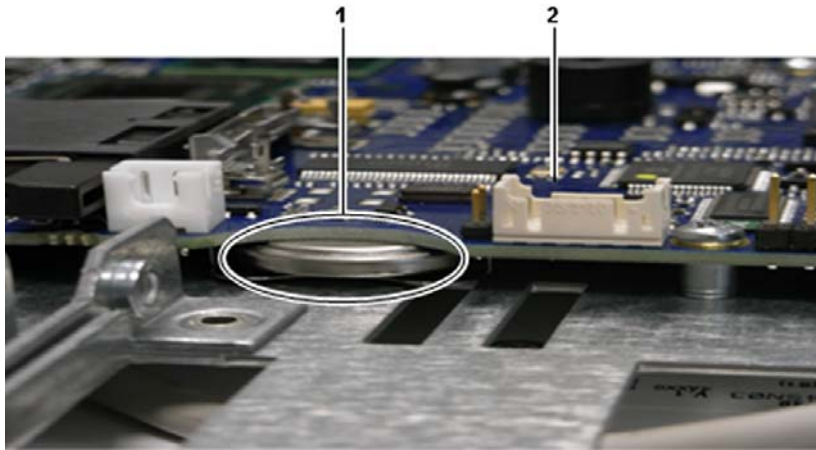

Location of the lithium battery

1	Lithium battery
2	Motherboard



WARNING

There is a risk of explosion if the battery is replaced by an incorrect type. The lithium battery must be replaced with an identical battery or of the same battery type (lithium battery 3,0V for a real-time clock, type: CR2032). The lithium battery type must be UL-listed.

To replace this battery, please proceed as follows:



◆ Procedure

1. **Close all applications and shut down the system properly**
2. **Disconnect the power cord from the power supply**
3. **Disconnect all peripheral devices**

The system should lay on a flat, clean surface with the front panel facing downwards. Make sure that the display surface is protected against scratching and damage.

4. **GN07: Unscrew the screws that secure the cover**
GN10/12/15: Unscrew the screws that secure the metal cover on the optional interface area
5. **Remove the cover and put it aside**

6. **Pull the battery outwards**
7. **Position the new lithium battery in the battery holder with the positive (+) pole facing up**
8. **Gently push the battery as far as it goes into the holder**
Make sure that you insert the battery correctly. The positive pole must be facing up!
9. **Put the cover back on**
10. **When the cover is firmly in place, fasten the screws**



◆ NOTE

Do not dispose of lithium batteries in domestic waste. Dispose of the battery according to the local regulations dealing with the disposal of hazardous materials (e.g. take it to the collection points for old batteries).

Chapter 4

Technical Data

4.1 General Specifications

GN series		GN07	GN10	GN12	GN15
TFT LCD Display	Screen size Active area (H x V) [mm]	7" 152.4 x 91.44	10.4" 211.2 x 158.4	12.1" 246.0 x 184.5	15" 304.1 x 228.1
	Resolution (H x V) [pixel]	800 x 480	800 x 600 (SVGA)	800 x 600 (SVGA)	1024 x 768 (XGA)
	Pixel pitch (H x V) [mm]	0.1905 x 0.1905	0.264 x 0.264	0.3075 x 0.3075	0.297 x 0.297
	Color depth	262k			16.2M
	Backlight	33-LED	1 x CCFL	2 x CCFL	
	Brightness cd/m ²	330	230	400	350
	Control signal	1x 6bit LVDS			
	Viewing angle (°) (r / l / u / d)	60 / 60 / 40 / 55	70 / 70 / 55 / 65	70 / 70 / 50 / 60	70 / 70 / 65 / 60
	Contrast ratio	400:1	500:1	500:1	700: 1
Touch screen	4 wire resistive analog				
Single-board computer with Intel® Atom™ processor N270 1.6 GHz	Yes				
Lithium battery 3.0 V for real-time clock. Type CR2032, UL-listed	Yes				
Reset button (RESET)	Yes				
Power button (PWR)	Yes				
Power supply input (see note)	12V DC (2.8A max.) to 24V DC (1.8A max.) ±10%				
Status LEDs, system and storage medium	Yes				
USB 2.0 interface	2 x	3 x			
Ethernet interface (10/100/1000Mbps) (LAN0, LAN1)	2 x				
VGA interface	1 x				
Serial RS232 interface (COM1)	1 x				
Protection class IP65 (front side)	Yes				
Optional interfaces: • Serial RS422/485 • Serial RS232 • Industrial fieldbus • Industrial Ethernet (not GN07)	1 x	2 x			
Mini PCIexpress slot	Yes				
Compact flash card slot	1 x				
Storage media	CF card				
BIOS	Phoenix/Phoenix-Award				
Operating system	Standard: Windows CE (Other operating systems available upon request.)				
DC power connector (3 pin)	1 x				

GN series	GN07	GN10	GN12	GN15
DC power plug (3 pin)	1 x			
Mounting clamps	4 x (1 screw)	8 x (1 screw)	6 x (2 screws)	8 x (2 screws)

**◆ NOTE**

The DC power supply must be able to output 50W to cope with the inrush current.

4.2 Environmental Specifications

Item	Specification
Thermal management	Passive cooling for CPU and system
Operating temperature / relative humidity	0 ... +45°C, 20 – 90% (non-condensing)
Storage / transit temperature / relative humidity	-20 ... +70°C, 10 – 90% (non-condensing)
Operating altitude	-300m to 3,000m
Storage / transit altitude	-300m to 4,500m
Operating shock	15G, 11ms duration, half-sinus
Storage / transit vibration	50G, 11ms duration, half-sinus
Operating vibration	10 – 58Hz ± 0.1 mm 58 – 500Hz; 1G
Storage / transit vibration	10 – 58Hz ± 0.15 mm 58 – 500Hz; 2.0G
Degree of protection	IP65 (front panel side)

4.3 Dimensions

Dimension	GN07	GN10	GN12	GN15
Height	168mm	277mm	312mm	354mm
Width	235mm	348mm	380mm	449.4mm
Depth (total)	50.3mm	49.6mm	57.1mm	55.6mm
Depth (without front plate)	47.3mm	45.6mm	51.1mm	51.6mm
Weight	2.6kg	3.6kg	4.9kg	6.5kg

4.3.1 Front Views

GN07

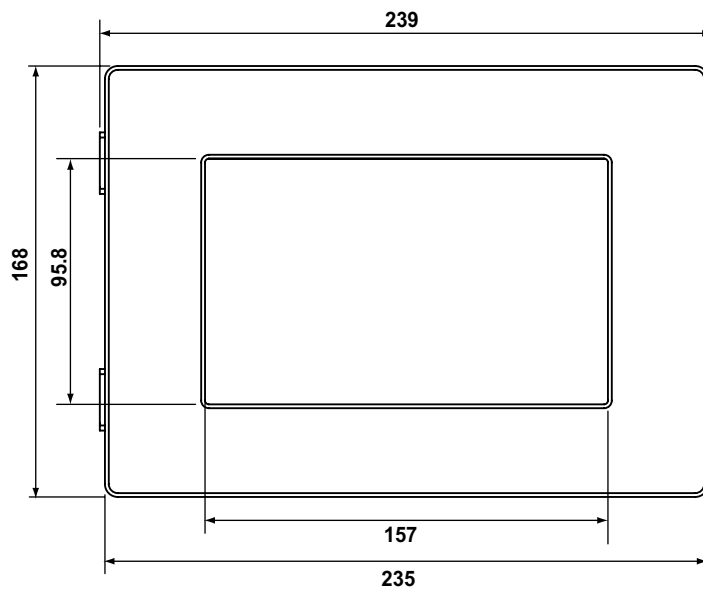

GN10

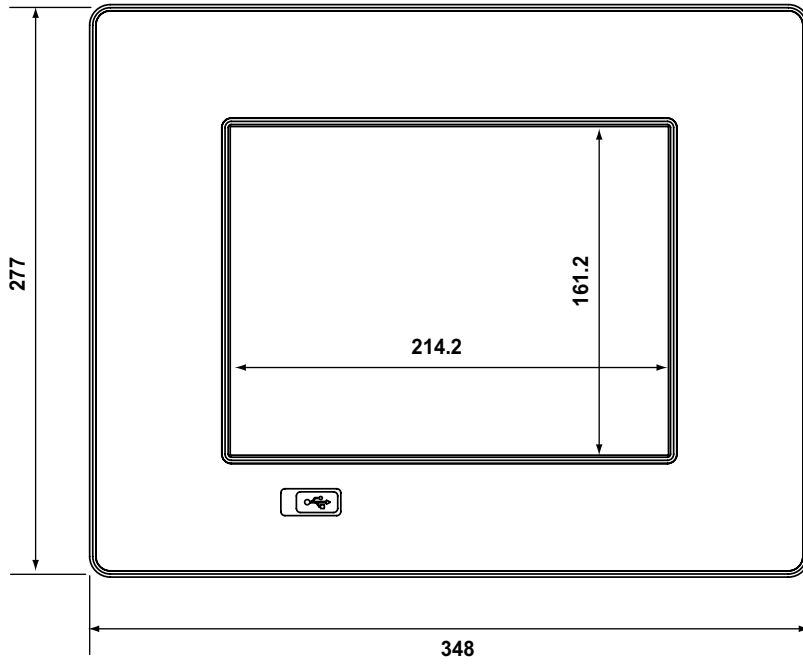

GN12

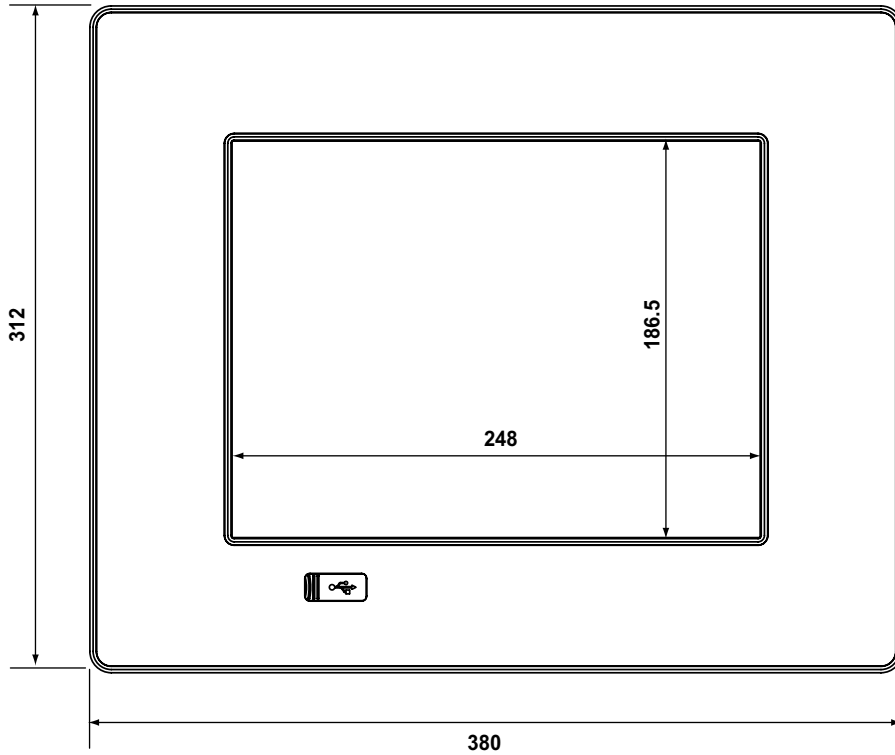

GN15

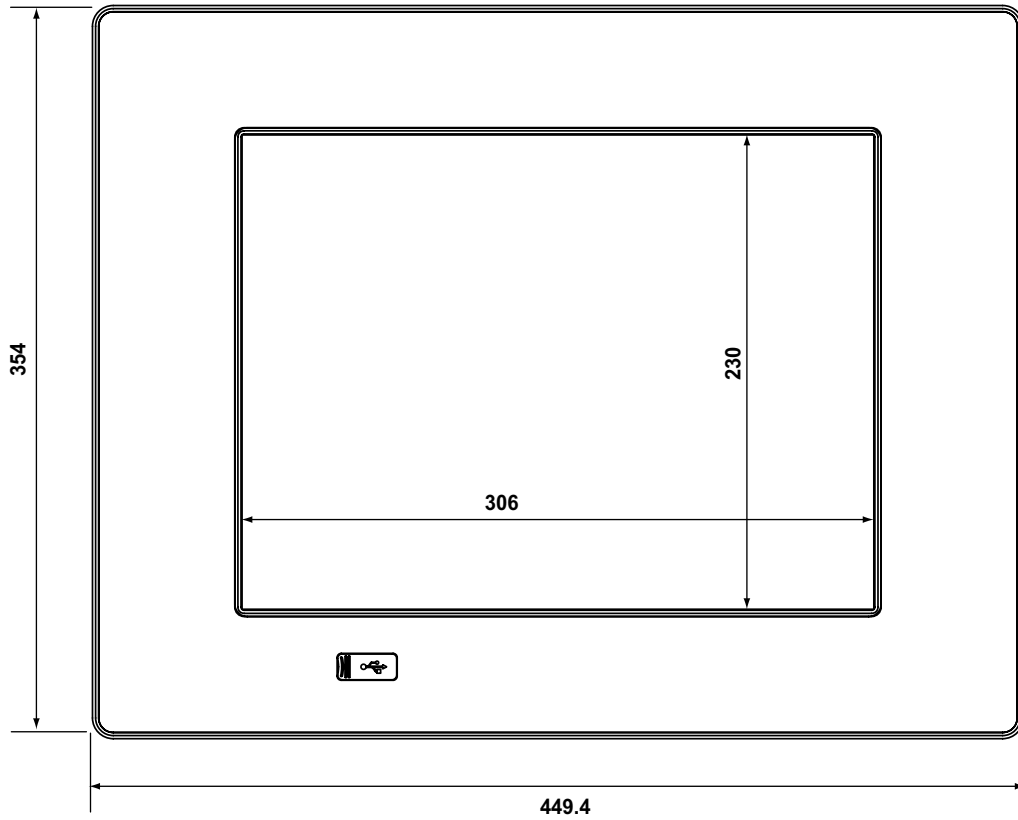

4.3.2 Rear and Right Side Views

GN07

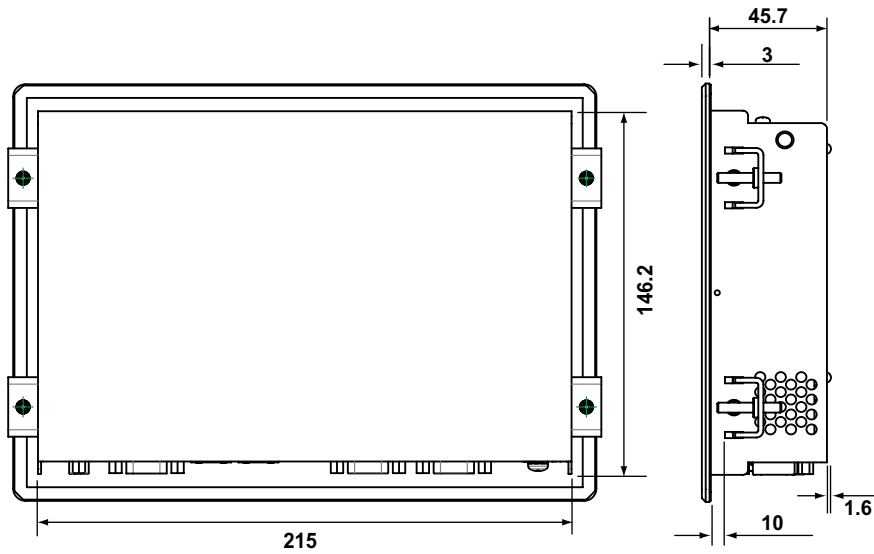

GN10

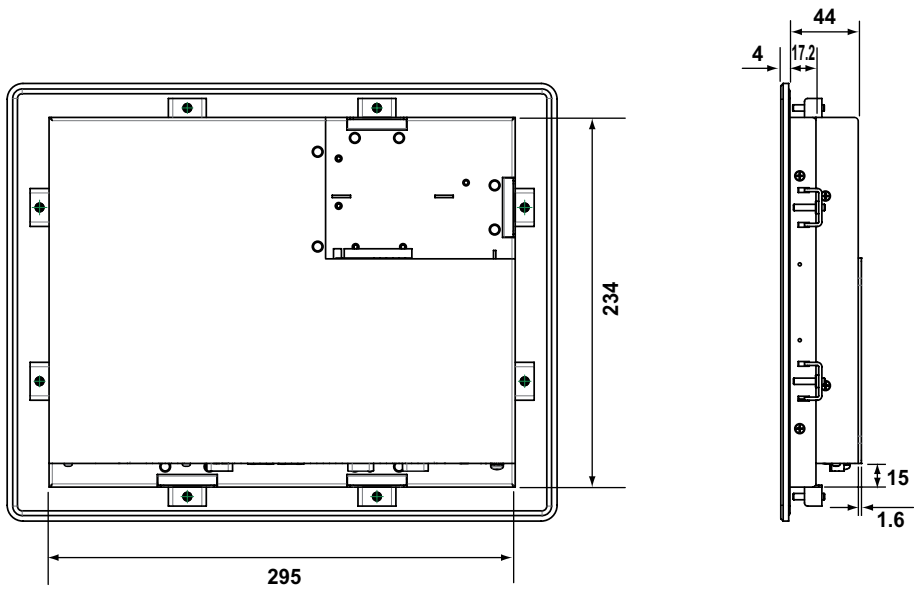

GN12

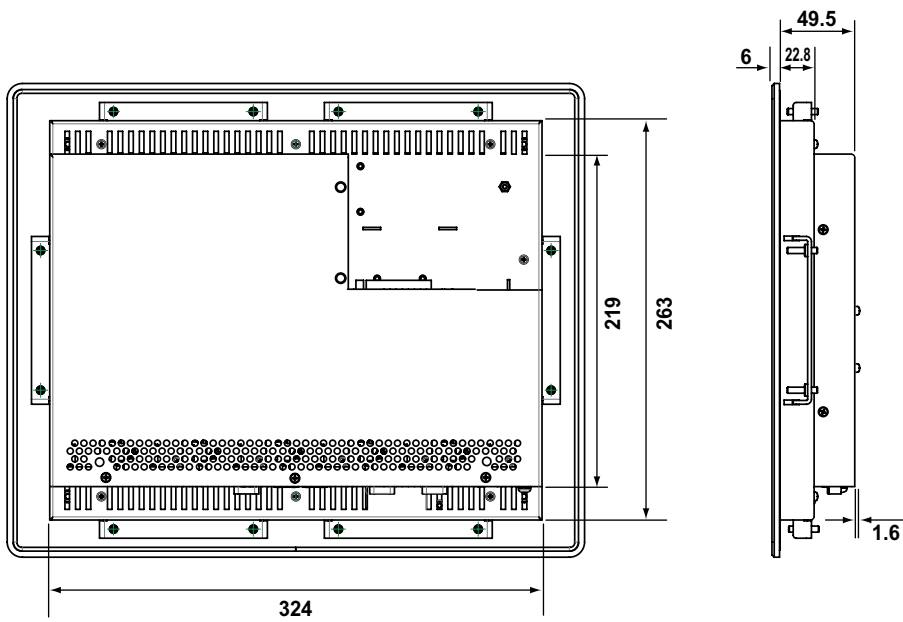

GN15

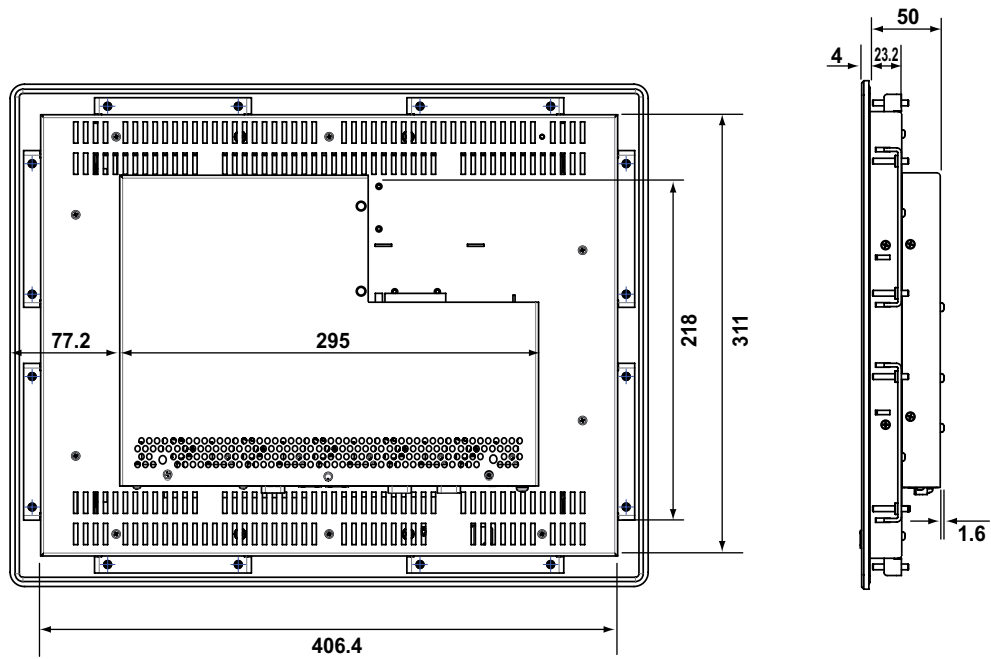

4.4 Pin Assignments

In this section you can find the pin assignments for the standard interfaces.

4.4.1 Ethernet Interfaces (LAN0 and LAN1)

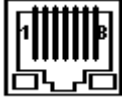
Pin No.	Signal name	RJ45 (female) connector
1	MDIO+	
2	MDIO-	
3	MDI1+	
4	MDI2+	
5	MDI2-	
6	MDI1-	
7	MDI3+	
8	MDI3-	
LED (green)	LINK / ACTIVE	
LED (off/green/yellow) 10/100/1000 Base-T		

4.4.2 USB Interfaces

Pin No.	Signal name	4-pin USB socket, type A, version 2.0/1.1
1	VCC	
2	Data -	
3	Data +	
4	Ground	

4.4.3 RS232 (COM1, COM2)

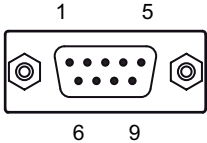
Pin	Signal short name	Long name	9-pin Sub-D plug (male)
1	DCD	Data carrier detect	
2	RxD	Receive data	
3	TxD	Transmit data	
4	DTR	Data terminal ready	
5	GND	Signal ground	
6	DSR	Data set ready	
7	RTS	Request to send	
8	CTS	Clear to send	
9	RI	Ring indicator	

4.4.4 RS422/RS485 Configured as RS422 (4-Channel Mode)

Use the DIP switches to configure the interfaces (see page 27).

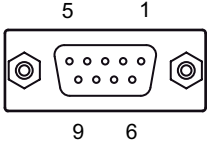
Pin	Signal short name	Long name	9-pin Sub-D plug (female)
1	TxD -	Transmit data -	
2	RxD +	Receive data +	
3	TxD +	Transmit data +	
4	RxD -	Receive data -	
5	GND	Signal ground	
6	RTS -	Request to send -	
7	RTS +	Request to send +	
8	CTS +	Clear to send +	
9	CTS -	Clear to send -	

4.4.5 RS422/RS485 Configured as RS485 (4-Wire Mode), Full Duplex, Bus Master

Use the DIP switches to configure the interfaces (see page 27).

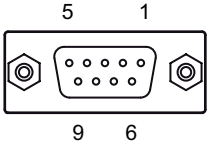
Pin	Signal short name	Long name	9-pin Sub-D plug (female)
1	TxD -	Transmit data -	
2	RxD +	Receive data +	
3	TxD +	Transmit data +	
4	RxD -	Receive data -	
5	GND	Signal ground	
6	NC	Not connected	
7	NC	Not connected	
8	NC	Not connected	
9	NC	Not connected	

4.4.6 RS422/RS485 Configured as RS485 (2-Wire Mode), Half Duplex

Use the DIP switches to configure the interfaces (see page 27).

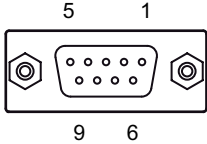
Pin	Signal name	9-pin Sub-D plug (female)
1	Data -)	
2	NC	
3	Data +)	
4	NC	
5	GND	
6	NC	
7	NC	
8	NC	
9	NC	

4.4.7 VGA Port (VGA)

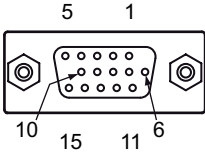
Pin	Signal name	15-pin Sub-D-Plug (female)
1	Analog red output	
2	Analog green output	
3	Analog blue output	
4	Not connected	
5	GND	
6	GND	
7	GND	
8	GND	
9	+5V (DDC)	
10	GND	
11	Not connected	
12	SDA (DDC)	
13	TTL Hsync	
14	TTL Vsync	
15	SCL (DDC)	

4.4.8 DC Power Connector

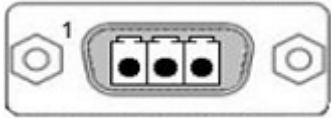
Pin	Signal name	3-pin POWER SUBCON (male)
1	0V input (-24V DC polarity on the unit panel)	
2	+24V DC (input) NC	
3	Functional earth	

4.5 Cables

Type of communication	Description	Product no.
RS232C	<ul style="list-style-type: none"> GN COM1 to PLC TOOL port (5-pin mini-DIN) Cable length: 3m 	AFC8513D
RS232C	<ul style="list-style-type: none"> GN COM1 to FP2 COM/MCU RS232 Cable length: 2m 	AIP81862E1D
RS232C	<ul style="list-style-type: none"> GN COM1 (9-pin Sub-D), loose wire Cable length: 3m 	AIGNCAB232D
Ethernet	You may use a commercially available Ethernet LAN cable to program the GN panel, for example.	—

RS232 connection cable wiring

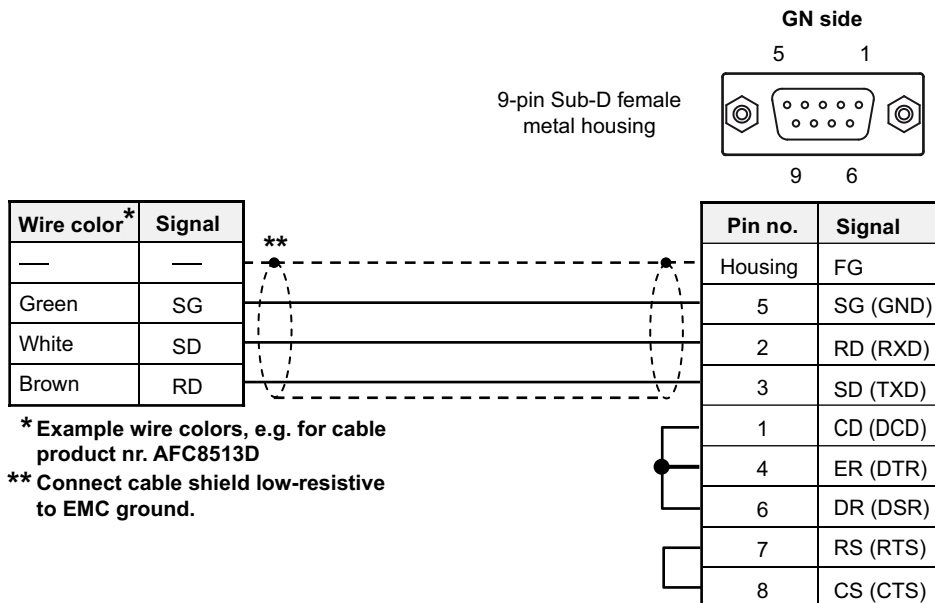

RS485 connection cable wiring

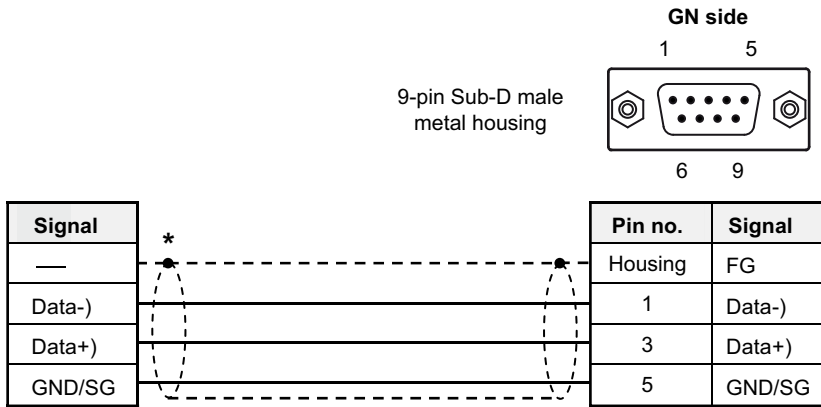

*** Connect cable shield low-resistive to EMC ground.**

Index

A

- Accessing Internal Components..... 43
- All Views 14
- Applicable Directives and Standards..... 8

B

- Battery 45
- BEFORE BEGINNING..... i
- Bottom View..... 26

C

- Cables..... 59
- Calibrating the Touch Screen 17
- Calibration..... 17, 21, 24
- Calibration under Windows® CE 18
- Calibration under Windows® XP 21
- Calibration under Windows® XP
Embedded..... 24
- CE directives..... 8
- Cleaning..... 25
- Compact flash card..... 48
- Compact flash card slot 31, 34
- Compact Flash Card Slot 31
- Configuration of the RS422/RS485 Port. 43
- Connecting the System to the Power
Supply 37
- Connecting to the DC Power Supply 38

D

- DC power connector 28, 37, 58
- DC Power Connector..... 28, 58
- DC power plug 10, 28, 37
- DC Power Plug 37

- Dimensions 51, 53
- DIP switches 27
- Display 17, 48
- Display with Touch Screen 17

E

- Electromagnetic compatibility 7
- Electromagnetic Compatibility 7
- Electrostatic discharge 5
- Electrostatic Discharge (ESD) 5
- Environmental Specifications 50
- Ethernet 29, 56
- Ethernet Interfaces (LAN0 and LAN1).... 56

F

- FCC statement..... 6
- FCC Statement 6
- Front Plates 17
- Front View..... 16
- Front Views..... 51

G

- General Specifications..... 48
- Grounding 5, 30
- Grounding Methods 5
- Grounding Screw (M4) with Lock Washers
..... 30

H

- Hampshire TSHARK software 17, 21, 24

I

- Important Symbols..... ii
- Interface configuration 27
- Interfaces 26, 27, 29
- Introduction 1

L

LAN0 and LAN1 Ethernet Interface Connectors	29
Left and Right Side View	32

M

Material of front plate	17
Monitor	29, 58
Mounting clamp.....	10, 31, 34, 40
Mounting the System to a Subframe or Panel	40

O

Opening the system	43
Optional Interfaces.....	26
Overview	4

P

Panel cutout	40
Pin Assignments	56
Power button.....	26
Power LEDs	29
Product Description.....	13
Product Parts	10
Protection class.....	40, 48, 50

R

Real-time clock	45
Rear and Right Side Views.....	53
Rear View	34
Record of Changes.....	64
Replace battery.....	45
Replacing the Lithium Battery.....	45
Reset button.....	29
Reset Button	29

RS232 (COM1, COM2).....	56
RS422/RS485 Configured as RS422 (4-Channel Mode)	57
RS422/RS485 Configured as RS485 (2-Wire Mode), Half Duplex.....	57
RS422/RS485 Configured as RS485 (4-Wire Mode), Full Duplex, Bus Master	57
RS422/RS485 Serial Interface.....	27
Rubber coat	16

S

Safety Instructions	2
Scope of Delivery.....	9
Serial interface.....	26, 27, 56, 57
Single-Board Computer	36
Specifications.....	48, 50
Status LEDs	29
Stylus	10, 17

T

Technical Data.....	47
Timeout.....	27
Top View	31
Touch Screen Care and Cleaning	25
Type label	11, 32, 34
Type Label and Product Identification	11

U

USB interface.....	16, 56
USB Interface on the Front.....	16
USB Interfaces.....	56

V

Ventilation holes.....	4, 31
VGA interface.....	29, 58

VGA Interface Connector29
VGA Port (VGA).....58

Record of Changes

Manual No.	Date	Description of Changes
ACGM0192V1EN	April 2010	First edition.
ACGM0192V2EN	June 2010	Calibration for Windows CE added.

North America

Europe

Asia Pacific

China

Japan

Panasonic Electric Works Global Sales Companies

Europe

▶ Headquarters	Panasonic Electric Works Europe AG	Rudolf-Diesel-Ring 2, 83607 Holzkirchen, Tel. +49 (0) 8024 648-0, Fax +49 (0) 8024 648-111, www.panasonic-electric-works.com
▶ Austria	Panasonic Electric Works Austria GmbH	Rep. of PEWDE, Josef Madersperger Str. 2, 2362 Biedermannsdorf, Tel. +43 (0) 2236-26846, Fax +43 (0) 2236-46133, www.panasonic-electric-works.at
	PEW Electronic Materials Europe GmbH	Ennshafenstraße 30, 4470 Enns, Tel. +43 (0) 7223 883, Fax +43 (0) 7223 88333, www.panasonic-electronic-materials.com
▶ Benelux	Panasonic Electric Works Sales Western Europe B.V.	De Rijn 4, (Postbus 211), 5684 PJ Best, (5680 AE Best), Netherlands, Tel. +31 (0) 499 372727, Fax +31 (0) 499 372185, www.panasonic-electric-works.nl
▶ Czech Republic	Panasonic Electric Works Czech s.r.o.	Prumtyslová 1, 34815 Planá, Tel. (+420-)374799990, Fax (+420-)374799999, www.panasonic-electric-works.cz
▶ France	Panasonic Electric Works Sales Western Europe B.V.	Succursale française, 10, rue des petits ruisseaux, 91371 Verrières le Buison, Tél. +33 (0) 1 6013 5757, Fax +33 (0) 1 6013 5758, www.panasonic-electric-works.fr
▶ Germany	Panasonic Electric Works Europe GmbH	Rudolf-Diesel-Ring 2, 83607 Holzkirchen, Tel. +49 (0) 8024 648-0, Fax +49 (0) 8024 648-111, www.panasonic-electric-works.com
▶ Hungary	Panasonic Electric Works Europe AG	Magyarországi Közvetlen Kereskedelmi Képviselet, 1117 Budapest, Neumann János u. 1., Tel. +36(0)1482 9258, Fax +36 (0) 1482 9259, www.panasonic-electric-works.hu
▶ Ireland	Panasonic Electric Works UK Ltd.	Dublin, Tel. +353 (0) 14600969, Fax +353 (0) 14601131, www.panasonic-electric-works.co.uk
▶ Italy	Panasonic Electric Works Italia s.r.l.	Via del Commercio 3-5 (Z.I. Ferlina), 37012 Bussolengo (VR), Tel. +39 (0) 456752711, Fax +39 (0) 456700444, www.panasonic-electric-works.it
▶ Nordic Countries	Panasonic Electric Works Nordic AB	Sjöängsvägen 10, 19272 Sollentuna, Sweden, Tel. +46 859476680, Fax +46 859476690, www.panasonic-electric-works.se
	PEW Fire & Security Technology Europe AB	Jungmansgatan 12, 21119 Malmö, Tel. +46 40697-7000, Fax +46 40697-7099, www.panasonic-fire-security.com
▶ Poland	Panasonic Electric Works Polska sp. z o.o.	Al. Krakowska 4/6, 02-284 Warszawa, Tel. +48 (0) 22 338-11-33, Fax +48 (0) 22 338-12-00, www.panasonic-electric-works.pl
▶ Portugal	Panasonic Electric Works España S.A.	Portuguese Branch Office, Avda Adelino Amaro da Costa 728 R/C J, 2750-277 Cascais, Tel. +351 214812520, Fax +351 214812529
▶ Spain	Panasonic Electric Works España S.A.	Barajas Park, San Severo 20, 28042 Madrid, Tel. +34 913293875, Fax +34 913292976, www.panasonic-electric-works.es
▶ Switzerland	Panasonic Electric Works Schweiz AG	Grundstrasse 8, 6343 Rotkreuz, Tel. +41 (0) 417997050, Fax +41 (0) 417997055, www.panasonic-electric-works.ch
▶ United Kingdom	Panasonic Electric Works UK Ltd.	Sunrise Parkway, Linford Wood, Milton Keynes, MK14 6LF, Tel. +44(0) 1908 231555, +44(0) 1908 231599, www.panasonic-electric-works.co.uk

North & South America

▶ USA	PEW Corporation of America	629 Central Avenue, New Providence, N.J. 07974, Tel. +1-908-464-3550, Fax +1-908-464-8513, www.pewa.panasonic.com
--------------	-----------------------------------	---

Asia Pacific/China/Japan

▶ China	Panasonic Electric Works (China) Co., Ltd.	Level 2, Tower W3, The Tower Oriental Plaza, No. 2, East Chang An Ave., Dong Cheng District, Beijing 100738, Tel. (010) 5925-5988, Fax (010) 5925-5973, www.pewc.panasonic.cn
▶ Hong Kong	Panasonic Electric Works (Hong Kong) Co., Ltd.	RM1205-9, 12/F, Tower 2, The Gateway, 25 Canton Road, Tsimshatsui, Kowloon, Hong Kong, Tel. (8520) 2956-3118, Fax (852) 2956-0398
▶ Japan	Panasonic Electric Works Co., Ltd.	1048 Kadoma, Kadoma-shi, Osaka 571-8686, Japan, Tel. (06)-6908-1050, Fax (06)-6908-5781 http://panasonic-electric-works.net
▶ Singapore	Panasonic Electric Works Asia Pacific Pte. Ltd.	101 Thomson Road, #25-03/05, United Square, Singapore 307591, Tel. (06255)-5473, Fax (06253)-5689