

Features

- 2-channel signal conditioner
- 24 V DC supply (Power Rail)
- Dry contact or NAMUR inputs
- Relay contact output
- Line fault detection (LFD)
- Housing width 12.5 mm
- Up to SIL2 acc. to IEC 61508

Function

This signal conditioner transfers digital signals (NAMUR sensors/mechanical contacts) from the field to the control system.

The proximity sensor or switch controls a form A normally open relay contact for the load. The normal output state can be reversed using switches S1 and S2. Switch S3 is used to enable or disable line fault detection of the field circuit.

During an error condition, relays revert to their de-energized state and LEDs indicate the fault according to NAMUR NE44.

A unique collective error messaging feature is available when used with the Power Rail system.

Due to its compact housing design and low heat dissipation, this device is useful for detecting positions, end stops, and switching states in space-critical applications.

Assembly

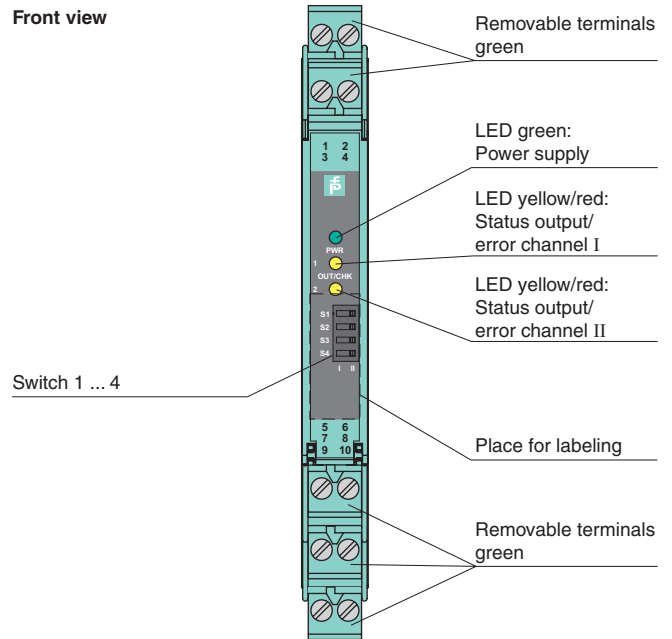

CE

SIL2

Connection

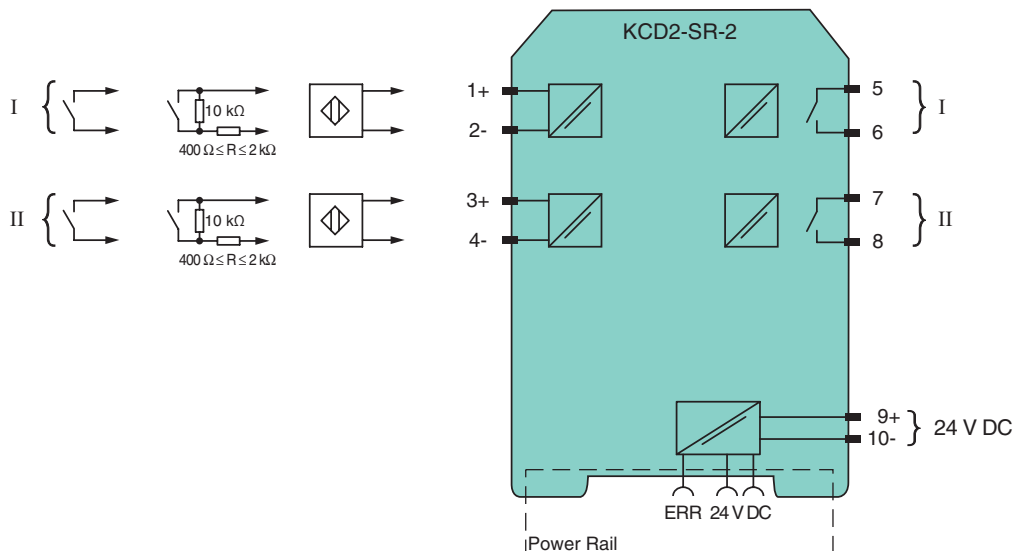

Release date 2012-12-07 16:05 Date of issue 2013-03-01 216718_eng.xml

General specifications	
Signal type	Digital Input
Supply	
Connection	Power Rail or terminals 9+, 10-
Rated voltage	19 ... 30 V DC
Ripple	≤ 10 %
Rated current	≤ 30 mA
Power loss	≤ 600 mW
Power consumption	≤ 600 mW
Input	
Connection	terminals 1+, 2-; 3+, 4-
Rated values	acc. to EN 60947-5-6 (NAMUR)
Open circuit voltage/short-circuit current	approx. 10 V DC / approx. 8 mA
Switching point/switching hysteresis	1.2 ... 2.1 mA / approx. 0.2 mA
Line fault detection	breakage I ≤ 0.1 mA , short-circuit I ≥ 6.5 mA
Pulse/Pause ratio	≥ 20 ms / ≥ 20 ms
Output	
Connection	terminals 5, 6; 7, 8
Output I	signal ; relay
Output II	signal ; relay
Contact loading	253 V AC/2 A/cos φ > 0.7; 126.5 V AC/4 A/cos φ > 0.7; 30 V DC/2 A resistive load
Minimum switch current	2 mA / 24 V DC
Energized/De-energized delay	≤ 20 ms / ≤ 20 ms
Mechanical life	10 ⁷ switching cycles
Transfer characteristics	
Switching frequency	≤ 10 Hz
Electrical isolation	
Input/Output	reinforced insulation acc. to EN 50178, rated insulation voltage 300 V _{eff}
Input/power supply	reinforced insulation acc. to EN 50178, rated insulation voltage 300 V _{eff}
Output/power supply	reinforced insulation acc. to EN 50178, rated insulation voltage 300 V _{eff}
Input/input	Basic insulation according to EN 50178, rated insulation voltage 300 V _{eff}
Output/Output	reinforced insulation acc. to EN 50178, rated insulation voltage 300 V _{eff}
Directive conformity	
Electromagnetic compatibility	
Directive 2004/108/EC	EN 61326-1:2006
Low voltage	
Directive 2006/95/EC	EN 61010-1:2010
Conformity	
Electromagnetic compatibility	NE 21
Protection degree	IEC 60529
Ambient conditions	
Ambient temperature	-20 ... 60 °C (-4 ... 140 °F)
Mechanical specifications	
Protection degree	IP20
Mass	approx. 100 g
Dimensions	12.5 x 114 x 119 mm (0.5 x 4.5 x 4.7 in) , housing type A2
Mounting	on 35 mm DIN mounting rail acc. to EN 60715:2001
General information	
Supplementary information	Statement of Conformity, Declaration of Conformity, Attestation of Conformity and instructions have to be observed where applicable. For information see www.pepperl-fuchs.com .

Release date 2012-12-07 16:05 Date of issue 2013-03-01 216718_eng.xml

Configuration

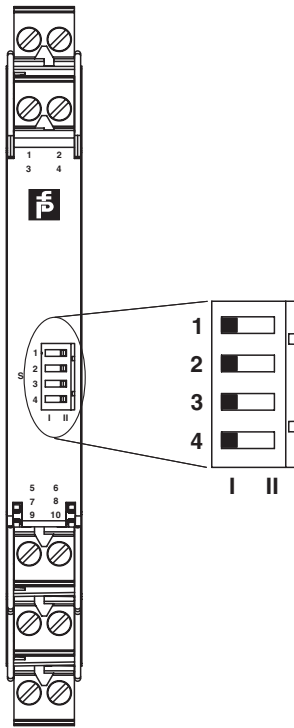

Switch position

S	Function		Position
1	Mode of operation Output I (relay) energized	with high input current	I
		with low input current	II
2	Mode of operation Output II (relay) energized	with high input current	I
		with low input current	II
3	Line fault detection Input I	ON	I
		OFF	II
4	Line fault detection Input II	ON	I
		OFF	II

Operating status

Control circuit	Input signal
Initiator high impedance/ contact opened	low input current
Initiator low impedance/ contact closed	high input current
Lead breakage, lead short-circuit	Line fault

Factory settings: switch 1, 2, 3 and 4 in position I

Maximum switching power of output contacts

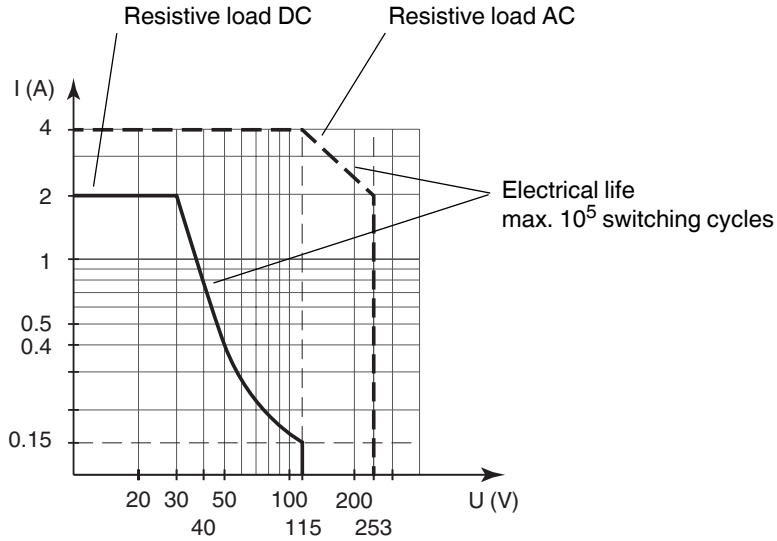

The maximum number of switching cycles is depending on the electrical load and may be higher when reduced currents and voltages are applied.

Release date 2012-12-07 16:05 Date of issue 2013-03-01 216718_eng.xml

Accessories

Power feed module KFD2-EB2

The power feed module is used to supply the devices with 24 V DC via the Power Rail. The fuse-protected power feed module can supply up to 150 individual devices depending on the power consumption of the devices. A galvanically isolated mechanical contact uses the Power Rail to transmit collective error messages.

Power Rail UPR-03

The Power Rail UPR-03 is a complete unit consisting of the electrical inset and an aluminium profile rail 35 mm x 15 mm. To make electrical contact, the devices are simply engaged.

Profile Rail K-DUCT with Power Rail

The profile rail K-DUCT is an aluminum profile rail with Power Rail insert and two integral cable ducts for system and field cables. Due to this assembly no additional cable guides are necessary.



Power Rail and Profile Rail must not be fed via the device terminals of the individual devices!