

Braking Devices VersiBrake LT [6 – 30A] 3.03

Features:

- ▣ DC braking with one-way rectification
- ▣ suitable for all asynchronous motors and for mono phase motors
- ▣ controlled by microcontroller
- ▣ easy mounting, also for retrofitting into existing plants
- ▣ wear-resistant and maintenance-free
- ▣ integrated braking contactor
- ▣ for snap-on mounting onto 35mm DIN rail
- ▣ degree of protection IP 20
- ▣ successor for braking devices type BR und BR-L



(photo similar)

**Braking devices
VB LT [6 – 30A]**
CE

Function:

- ▣ direct online start via motor contactor
- ▣ overload protection
- ▣ braking current control
- ▣ automatic remanence time optimization
- ▣ braking current infinitely adjustable 10-100%
- ▣ braking interrupt is possible
- ▣ restart 1,2s after braking interrupt
- ▣ braking time adjustable
- ▣ potential-free output for motor contactor
Interlocking during braking;
also usable to energize the star contactor
during braking

Typical Applications:

- saws
- conveyors
- woodworking machines
- grinding machines
- screening machines
- vibrating feeders
- others

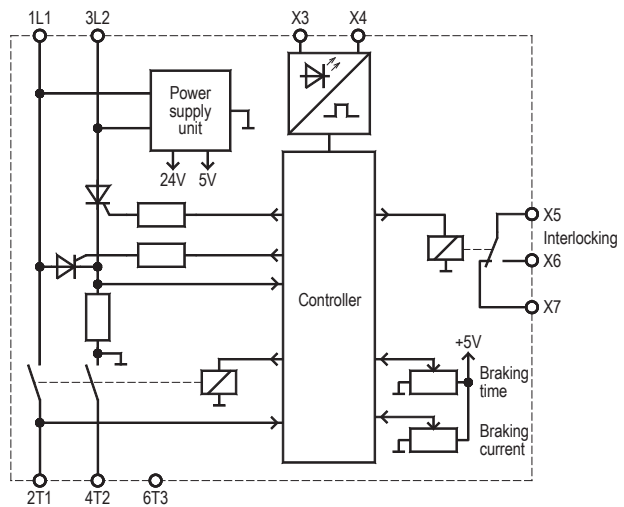

Type designation	VB 230-6LT	VB 230-25LT	VB 230-30LT	VB 400-6LT	VB 400-25LT	VB 400-30LT
rated device current	6A	25A	30A	6A	25A	30A
mains voltage acc. To DIN EN 50160 (IEC 38)	220/240V ±10% 50/60Hz			380/415V ±10% 50/60Hz		
order number printed circuit-board version	2B200.23006	2B200.23025	2B200.23030	2B200.40006	2B200.40025	2B200.40030

Please observe supplementary sheet with dimensioning rules!

Technical data	VB 230-6LT	VB 230-25LT	VB 230-30LT	VB 400-6LT	VB 400-25LT	VB 400-30LT
mains voltage acc. to DIN EN 50160 (IEC 38)	220/240V ±10% 50/60Hz			380/415V ±10% 50/60Hz		
power draw of electronics	3 VA					
recommended for rated motor current up to	0,3 ... 3A	2 ... 12,5A	2 ... 15A	0,3 ... 3A	2 ... 12,5A	2 ... 15A
rated device current upto a braking time of 20s	6A	25A	30A	6A	25A	30A
rated device current upto a braking time of 30s	6A	17A	20A	6A	17A	20A
max. braking frequency at a braking time of 5s	1/8s	1/60s	1/90s	1/8s	1/60s	1/90s
I ² t-value of power semiconductors in A ² s	310	1250	1350	310	1250	1350
braking voltage	0 ... 110VDC			0 ... 220VDC		
max. braking time	0 ... 30s (special device 0 ... 60s available)					
contact rating (control relay)	3A/250VAC; 3A/30VDC					
delay time for reduction of residual e.m.f.	self-optimizing in the range between 0,2 ... 1,8s					
max. cross-sectional area for connection	2x 2,5mm ² per terminal					
ambient / storage temperature	0°C ... 45°C / -25°C ... 75°C					
weight / kg	0,6					

Note:

Please pay attention and consider for the operation of IE3 motors while dimensioning of softstarters and dc brakes the resulting higher starting and braking currents.

For the use of IE3 motors we highly recommend to dimension and design the needed softstarters and braking devices one size higher.

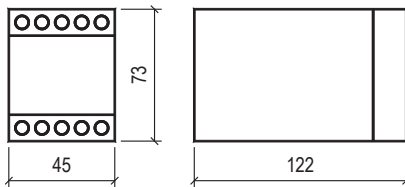
Dimensions:

All dimensions in mm

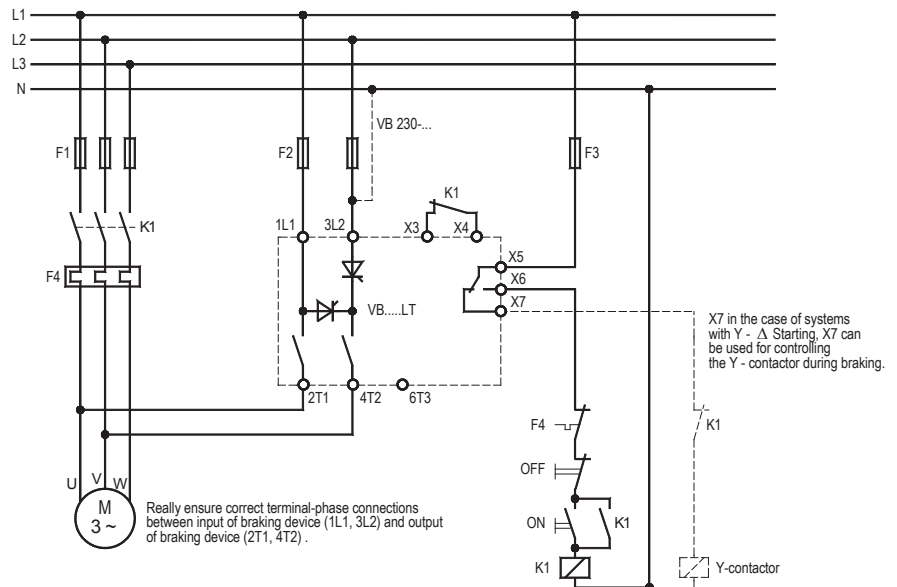
Connection Diagram:**EMC**

The limit values for emitted interference according to the applicable device standards do not rule out the possibility that receivers and susceptible electronic devices within a radius of 10m are subjected to interference. If such interference, which is definitely attributable to the operation of the braking devices "VB", occurs, the emitted interference can be reduced by taking appropriate measures.

Such measures are, e.g.:

To connect reactors (3mH) or a suitable mains filter in series before the braking device, or to connect X-capacitors (0,15μF) in parallel to the supply voltage terminals.