

## Patch panels - FL-PP-RJ45-SC - 2901643

Please be informed that the data shown in this PDF Document is generated from our Online Catalog. Please find the complete data in the user's documentation. Our General Terms of Use for Downloads are valid (<http://phoenixcontact.com/download>)



Patch panel, one RJ45 socket to 8 screw connection terminal blocks (1:1 assignment), CAT5e, 10/100/1000 Mbps, DIN rail mounting, IP20, option of shield contacting on DIN rail via jumpers

### Why buy this product

- Safe shield connection to ground potential
- 10/100/1000 Mbps
- Mounting on a DIN rail
- CAT5e
- Optional shield connection via jumpers



### Key Commercial Data

Packing unit	10 STK
GTIN	 4 046356 623391
GTIN	4046356623391
Weight per Piece (excluding packing)	58.080 g
Weight per piece (including packing)	60.500 g
Custom tariff number	85366990
Country of origin	Germany
Sales Key	M1 - Communication Techn.

### Technical data

#### Dimensions

Width	29 mm
Height	90 mm
Depth	53 mm

#### Ambient conditions

Ambient temperature (operation)	-25 °C ... 70 °C
Ambient temperature (storage/transport)	-25 °C ... 85 °C

# Patch panels - FL-PP-RJ45-SC - 2901643

## Technical data

### Ambient conditions

Permissible humidity (operation)	25 % ... 95 % (non-condensing)
Degree of protection	IP20

### General

Net weight	58.08 g
Housing material	PVC / PA
Color	green
MTBF	6702 Years (Telcordia standard, 25°C temperature, 21% operating cycle (5 days a week, 8 hours a day))
	2962 Years (Telcordia standard, 40°C temperature, 34.25% operating cycle (5 days a week, 12 hours a day))
ATEX	# II 3 G Ex nA IIC Gc U (Please follow the special installation instructions in the documentation!)

### Serial interface

Interface 1	Ethernet interface, 10/100/1000Base-T(X) according to IEEE 802.3u
No. of ports	1
Connection method	Screw connection
Transmission length	100 m (including patch cables)
Conductor cross section solid min.	0.14 mm <sup>2</sup>
Conductor cross section solid max.	1.5 mm <sup>2</sup>
Conductor cross section flexible min.	0.14 mm <sup>2</sup>
Conductor cross section flexible max.	1 mm <sup>2</sup>
Conductor cross section AWG min.	26
Conductor cross section AWG max.	16
Torque	0.22 Nm ... 0.25 Nm
Pin assignment	1:1
Serial transmission speed	10/100/1000 Mbps
Interface 2	Ethernet interface, 10/100/1000Base-T(X) according to IEEE 802.3u
No. of ports	1
Connection method	RJ45 CAT5e

### Standards and Regulations

Type of test	Vibration resistance in acc. with EN 60068-2-6/IEC 60068-2-6
Test result	5g, 10...150 Hz, 2.5 h, in XYZ direction
Type of test	Shock in acc. with EN 60068-2-27/IEC 60068-2-27
Test result	25g, 11 ms period, half-sine shock pulse
ATEX	# II 3 G Ex nA IIC Gc U
Noxious gas test	ISA-S71.04-1985 G3 Harsh Group A

### Environmental Product Compliance

China RoHS	Environmentally Friendly Use Period = 50
	For details about hazardous substances go to tab "Downloads", Category "Manufacturer's declaration"

# Patch panels - FL-PP-RJ45-SC - 2901643

## Drawings

Dimensional drawing

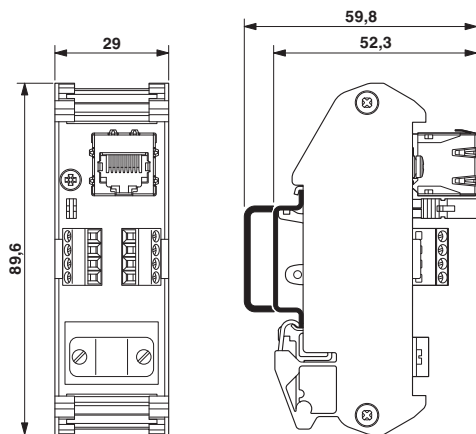

Circuit diagram

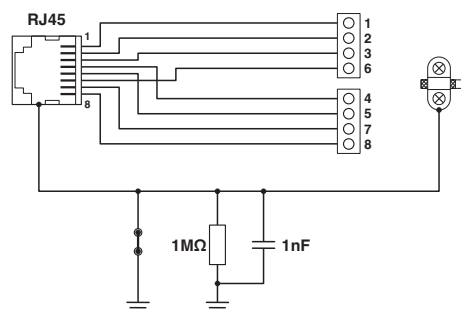

Schematic diagram

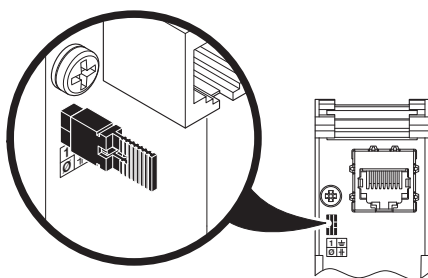

Schematic diagram

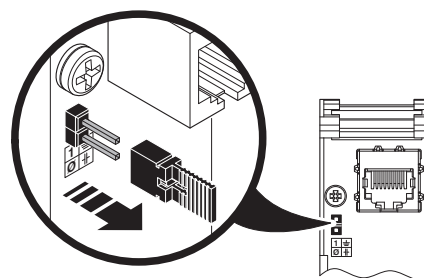

Shield connection direct to PE

Shield connection to PE via RC element

## Classifications

eCl@ss

eCl@ss 4.0	27250591
eCl@ss 4.1	27240409
eCl@ss 5.0	27259207
eCl@ss 5.1	27230207
eCl@ss 6.0	27230207
eCl@ss 7.0	27230207
eCl@ss 8.0	19170112
eCl@ss 9.0	19170112

ETIM

ETIM 3.0	EC000313
ETIM 4.0	EC001128
ETIM 5.0	EC002599
ETIM 6.0	EC002599

# Patch panels - FL-PP-RJ45-SC - 2901643

## Classifications

### UNSPSC

UNSPSC 6.01	30211506
UNSPSC 7.0901	39121008
UNSPSC 11	39121008
UNSPSC 12.01	39121008
UNSPSC 13.2	26121604

## Approvals

### Approvals

Approvals

DNV / EAC

Ex Approvals

ATEX

### Approval details

DNV		<a href="http://exchange.dnv.com/tari/">http://exchange.dnv.com/tari/</a>	A-13414
-----	--	---	---------

EAC			EAC-Zulassung
-----	--	--	---------------

## Accessories

### Accessories

#### Data cable by the meter

Cable - FL CAT5 HEAVY - 2744814



CAT5-SF/UTP cable (J-02YS(ST)C HP 2 x 2 x 24 AWG), heavy-duty installation cable, 2 x 2 x 0.22 mm<sup>2</sup>, solid conductor, shielded, outer sheath: 7.8 mm diameter, inner sheath: 5.75 mm ± 0.15 mm diameter

## Patch panels - FL-PP-RJ45-SC - 2901643

### Accessories

Network cable - FL CAT5 FLEX - 2744830



CAT5-SF/UTP cable (J-LI02YS(ST)C H 2 x 2 x 26 AWG), light-duty, flexible installation cable 2 x 2 x 0.14 mm<sup>2</sup>, stranded, shielded, outer sheath: 5.75 mm ± 0.15 mm diameter

---

### Data cable preassembled

Network cable - FL CAT5 HEAVY CONF/ - 2744827



CAT5-SF/UTP cable (J-02YS(ST)C HP 2 x 2 x 24 AWG), heavy-duty installation cable, 2 x 2 x 0.22 mm<sup>2</sup>, solid conductor, shielded, outer sheath: 7.8 mm diameter, inner sheath: 5.75 mm ± 0.15 mm diameter, preassembled on both sides with RJ45 plug, crossover or line

Network cable - FL CAT5 FLEX CONF/ - 2744843



CAT5-SF/UTP cable (J-LI02YS(ST)C H 2 x 2 x 26 AWG), light-duty, flexible installation cable 2 x 2 x 0.14 mm<sup>2</sup>, stranded, shielded, outer sheath: 5.75 mm ± 0.15 mm diameter, preassembled on both sides with RJ45 plug, crossover or line assignment

---

### Data plug

RJ45 connector - VS-08-RJ45-5-Q/IP20 - 1656725



RJ45 connector, degree of protection: IP20, number of positions: 8, 1 Gbps, CAT5 (IEC 11801:2002), material: PA, connection method: IDC fast connection, connection cross section: AWG 26- 23, cable outlet: straight, color: traffic grey A RAL 7042

RJ45 connector - VS-08-RJ45-5-Q/IP20 BK - 1658008



RJ45 connector, degree of protection: IP20, number of positions: 8, 1 Gbps, CAT5 (IEC 11801:2002), material: PA, connection method: IDC fast connection, connection cross section: AWG 26- 23, cable outlet: straight, color: black

---

### Passive isolators

## Patch panels - FL-PP-RJ45-SC - 2901643

### Accessories

#### Network isolator - FL ISOLATOR 100-RJ/SC - 2313928



Passive network isolator for electrical isolation in Ethernet networks. This protects Ethernet devices from potential differences of up to 4 kV. Can be used for transmission speeds of up to 100 Mbps. Connection using RJ45 and COMBICON plug-in screw terminal block.

---

#### Network isolator - FL ISOLATOR 100-RJ/RJ - 2313931



Passive network isolator for electrical isolation in Ethernet networks. This protects Ethernet devices from potential differences of up to 4 kV. Can be used for transmission speeds of up to 100 Mbps. Possible to connect two RJ45 plugs.

---

#### Network isolator - FL ISOLATOR 1000-RJ/RJ - 2313915



Passive network isolator for electrical isolation in Ethernet networks. This protects Ethernet devices from potential differences of up to 4 kV. Can be used for transmission speeds of up to 1 Gbps. Possible to connect two RJ45 plugs.

---

#### Network isolator - FL ISOLATOR 100-M12 - 2902985



Passive network isolator for electrical isolation in Ethernet networks. For the protection of Ethernet devices against potential differences of up to 4 kV. Can be used for transmission speeds of up to 100 Mbps. Ethernet connection via two M12 sockets (D-coded).

---

#### Network isolator - FL ISOLATOR 100-M12 RMS - 2904671



Passive network isolator with pre-installed adapter for mounting on a DIN rail. Electrical isolation in Ethernet networks. For protection against potential differences up to 4 kV. Transmission speed of up to 100 Mbps. M12 sockets (D-coded).

---

### Patch cable

## Patch panels - FL-PP-RJ45-SC - 2901643

### Accessories

Patch cable - FL CAT5 PATCH 0,3 - 2832250



Patch cable, CAT5, assembled, 0.3 m

---

Patch cable - FL CAT5 PATCH 0,5 - 2832263



Patch cable, CAT5, assembled, 0.5 m

---

Patch cable - FL CAT5 PATCH 1,0 - 2832276



Patch cable, CAT5, assembled, 1 m

---

Patch cable - FL CAT5 PATCH 1,5 - 2832221



Patch cable, CAT5, assembled, 1.5 m

---

Patch cable - FL CAT5 PATCH 2,0 - 2832289



Patch cable, CAT5, assembled, 2 m

---

## Patch panels - FL-PP-RJ45-SC - 2901643

### Accessories

Patch cable - FL CAT5 PATCH 3,0 - 2832292



Patch cable, CAT5, assembled, 3 m

---

Patch cable - FL CAT6 PATCH 0,3 - 2891181



Patch cable, CAT6, pre-assembled, 0.3 m

---

Patch cable - FL CAT6 PATCH 0,5 - 2891288



Patch cable, CAT6, pre-assembled, 0.5 m

---

Patch cable - FL CAT6 PATCH 1,0 - 2891385



Patch cable, CAT6, pre-assembled, 1.0 m

---

Patch cable - FL CAT6 PATCH 1,5 - 2891482



Patch cable, CAT6, pre-assembled, 1.5 m

---



## Patch panels - FL-PP-RJ45-SC - 2901643

### Accessories

Patch cable - FL CAT6 PATCH 2,0 - 2891589



Patch cable, CAT6, pre-assembled, 2.0 m

---

Patch cable - FL CAT6 PATCH 3,0 - 2891686



Patch cable, CAT6, pre-assembled, 3.0 m

---

Patch cable - FL CAT6 PATCH 5,0 - 2891783



Patch cable, CAT6, pre-assembled, 5.0 m

---

Patch cable - FL CAT6 PATCH 7,5 - 2891880



Patch cable, CAT6, pre-assembled, 7.5 m

---

Patch cable - FL CAT6 PATCH 10 - 2891877



Patch cable, CAT6, pre-assembled, 10 m

---

## Patch panels - FL-PP-RJ45-SC - 2901643

### Accessories

Patch cable - FL CAT6 PATCH 12,5 - 2891369



Patch cable, CAT6, pre-assembled, 12.5 m

---

Patch cable - FL CAT6 PATCH 15,0 - 2891372



Patch cable, CAT6, pre-assembled, 15.0 m

---

Patch cable - FL CAT6 PATCH 20,0 - 2891576



Patch cable, CAT6, pre-assembled, 20.0 m

---

### Screwdriver tools

Screwdriver - SZF 0-0,4X2,5 - 1204504



Actuation tool, for ST terminal blocks, also suitable for use as a bladed screwdriver, size: 0.4 x 2.5 x 75 mm, 2-component grip, with non-slip grip

---

### Universal tools

Assembly tool - FL CRIMPTOOL - 2744869



Crimping pliers, for assembling the RJ45 plugs FL PLUG RJ45..., for assembly on site

---

## Patch panels - FL-PP-RJ45-SC - 2901643

### Accessories

Stripping tool - VS-CABLE-STRIP-VARIO - 1657407



Stripping tool, for the multi-level stripping of shielded cables

---

### Additional products

Patch panels - FL-PP-RJ45-SCC - 2901642



Patch panel, one RJ45 socket to 8 spring-cage connection terminal blocks (1:1 assignment), CAT5e, 10/100/1000 Mbps, DIN rail mounting, IP20, option of shield contacting on DIN rail via jumpers

---

Patch panels - FL-PP-RJ45-LSA - 2901645



Patch panel, one RJ45 socket to 8 IDC connection terminal blocks (1:1 assignment), CAT5e, 10/100/1000 Mbps, DIN rail mounting, IP20, option of shield contacting on DIN rail via jumpers

---

Patch panels - FL-PP-RJ45/RJ45 - 2901646



Patch panel, two RJ45 sockets (1:1 assignment), CAT5e, 10/100/1000 Mbps, DIN rail mounting, IP20, option of shield contacting on DIN rail via jumpers