

PW 4-POT-SCM/S - Panel feed-through terminal block



3056941

<https://www.phoenixcontact.com/de/produkte/3056941>

Please be informed that the data shown in this PDF document is generated from our online catalog. Please find the complete data in the user documentation. Our general terms of use for downloads are valid.



Panel feed-through terminal block, connection method: Push-in spring connection, Spade connection, number of positions: 1, load current: 18 A, cross section: 0.2 mm² - 4 mm², connection direction of the conductor to plug-in direction: 45 °, width: 8.1 mm, color: gray

Your advantages

- Time saving push-in connection, tools not required
- Defined contact force ensures that contact remains stable over the long term
- Intuitive operation due to color-coded actuating push button
- Tool-free snap-in principle enables easy mounting on the device panel
- Automatic panel thickness compensation enables universal use
- Reliable seal even with low-viscosity molding compounds

Commercial data

Item number	3056941
Packing unit	50 pc
Minimum order quantity	50 pc
Sales key	A1 - Reihenklemmen
Product key	AA1AEA
Catalog page	Page 601 (C-1-2013)
GTIN	4046356485517
Weight per piece (including packing)	9,086 g
Weight per piece (excluding packing)	8,71 g
Customs tariff number	85369010
Country of origin	CN

Technical data

Product properties

Product type	Panel feed-through terminal block
Product family	PW 4-POT-SCM
Number of positions	1
Pitch	8.1 mm
Number of connections	2
Number of rows	1
Number of potentials	1
Potentials	1

Data management status

Article revision	03
------------------	----

Insulation characteristics

Overvoltage category	III
Degree of pollution	3

Electrical properties

Nominal current I_N	18 A
Nominal voltage U_N	800 V
Rated voltage (III/3)	800 V
Rated surge voltage (III/3)	8 kV

Connection data

Connection technology

Connector system	PW 4
Nominal cross section	4 mm ²

Conductor connection exterior

Connection method	Push-in spring connection
Connection direction of the conductor to plug-in direction	45 °
Conductor cross section rigid	0.2 mm ² ... 4 mm ²
Conductor cross section flexible	0.2 mm ² ... 6 mm ²
Conductor cross section flexible, with ferrule without plastic sleeve	0.25 mm ² ... 6 mm ²
Conductor cross section, flexible, with ferrule, with plastic sleeve	0.25 mm ² ... 4 mm ²
2 conductors with the same cross section, flexible, with TWIN ferrule with plastic sleeve	0.5 mm ² ... 1 mm ²
Internal cylindrical gage	A4
Stripping length	10 mm

Conductor connection interior

Connection method	Spade connection
-------------------	------------------

PW 4-POT-SCM/S - Panel feed-through terminal block



3056941

<https://www.phoenixcontact.com/de/produkte/3056941>

Connection direction of the conductor to plug-in direction	0 °
------------------------------------------------------------	-----

Mounting

Attachment to feed-through panel

Tightening torque	0.5 Nm ... 0.6 Nm (Mounting screw torque)
-------------------	-------------------------------------------

Material specifications

Material data - contact

Note	WEEE/RoHS-compliant, free of whiskers according to IEC 60068-2-82/JEDEC JESD 201
Contact material	Cu alloy
Surface characteristics	tin-plated

Material data - housing

Color (Housing)	gray (7042)
Insulating material	PA
Insulating material group	I
CTI according to IEC 60112	600
Flammability rating according to UL 94	V0
Glow wire flammability index GWFI according to EN 60695-2-12	850
Glow wire ignition temperature GWIT according to EN 60695-2-13	775
Temperature for the ball pressure test according to EN 60695-10-2	125 °C

Material data – actuating element

Insulating material	PA
Insulating material group	I
CTI according to IEC 60112	600
Flammability rating according to UL 94	V0

Notes

Safety note

Safety note	<ul style="list-style-type: none">• Only electrically qualified personnel may install and operate the product. To recognize and prevent danger, the qualified personnel must be familiar with the basics of electrical engineering.• Observe the technical data provided here and refer to the documents listed under “Downloads”. The download area contains important information, such as installation notes, technical drawings, and 3D data.• To maintain the nominal voltage, cast the terminals on the inside.
-------------	-----------------------------------------------------------------------------------------------------------------------------------------------------------------------------------------------------------------------------------------------------------------------------------------------------------------------------------------------------------------------------------------------------------------------------------------------------------------------------------------------------------------------------------------------------------

Dimensions

PW 4-POT-SCM/S - Panel feed-through terminal block



3056941

<https://www.phoenixcontact.com/de/produkte/3056941>

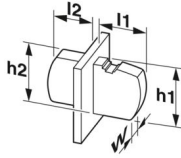
Dimensional drawing	
Pitch	8.1 mm
Width [w]	8.1 mm

External dimensions

Height [h1]	30 mm
Length [l1]	30.5 mm

Internal dimensions

Height [h2]	27 mm
Length [l2]	15.5 mm

Mechanical tests

Test for conductor damage and slackening

Specification	IEC 60947-7-1:2009-04
Result	Test passed

Pull-out test

Specification	IEC 60947-7-1:2009-04
Conductor cross section/conductor type/tractive force setpoint/actual value	0.2 mm ² / solid / > 10 N
	0.2 mm ² / flexible / > 10 N
	4 mm ² / solid / > 60 N
	4 mm ² / flexible / > 60 N

Electrical tests

Temperature-rise test

Specification	IEC 60512-5-1:2002-02
Requirement temperature-rise test	Increase in temperature ≤ 45 K

Short-time withstand current

Specification	IEC 60947-7-1:2009-04
---------------	-----------------------

Air clearances and creepage distances | 1. Insulation coordination

Application	Metal wall 1.0 mm ... 4.0 mm
Specification	IEC 60664-1:2007-04
Insulating material group	I
Comparative tracking index (IEC 60112)	CTI 600
Rated insulation voltage (III/3)	800 V
Rated surge voltage (III/3)	8 kV
minimum clearance value - non-homogenous field (III/3)	8 mm
minimum creepage distance (III/3)	10 mm

3056941

<https://www.phoenixcontact.com/de/produkte/3056941>

Environmental and real-life conditions

Vibration test

Specification	IEC 60068-2-6:2007-12
Frequency	10 Hz ... 150 Hz
Sweep speed	1 octave/min
Amplitude	0.35 mm (10 Hz ... 60.1 Hz)
Acceleration	5g (60.1 Hz ... 150 Hz)
Test duration per axis	2.5 h
Test directions	X-, Y- and Z-axis

Glow-wire test

Specification	IEC 60695-2-11:2000-10
Temperature	960 °C
Time of exposure	30 s

Ambient conditions

Ambient temperature (operation)	-40 °C ... 100 °C (Depending on the current carrying capacity/derating curve)
Ambient temperature (storage/transport)	-40 °C ... 70 °C
Relative humidity (storage/transport)	30 % ... 70 %
Ambient temperature (assembly)	-5 °C ... 100 °C

Packaging specifications

Type of packaging	packed in cardboard
-------------------	---------------------

PW 4-POT-SCM/S - Panel feed-through terminal block



3056941

<https://www.phoenixcontact.com/de/produkte/3056941>

Drawings

Dimensional drawing

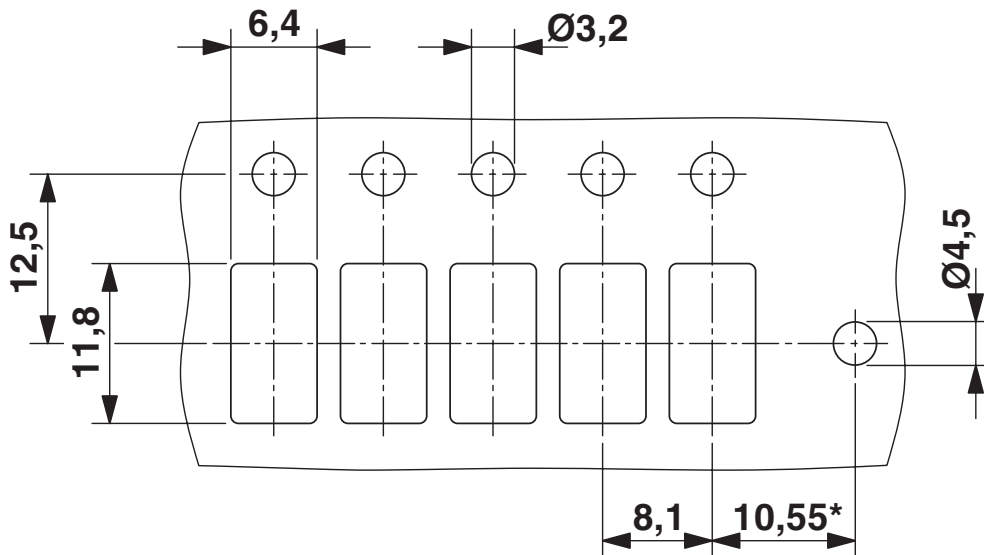

*Only when using the PW 4-F flange plate

Diagram

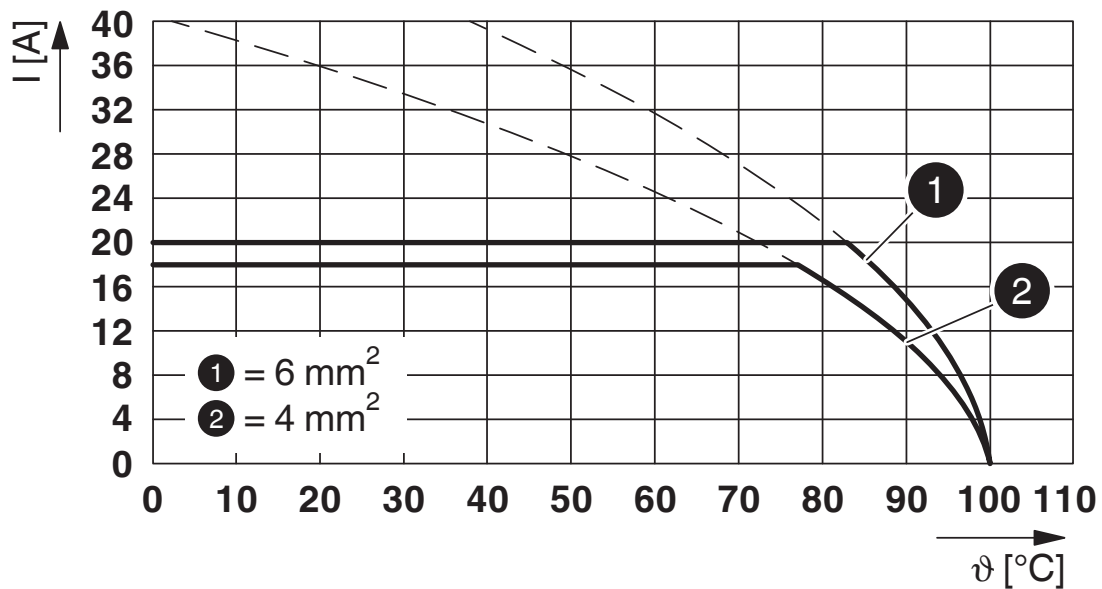

Type: PW(O) 4-POT-SCM(/S)

PW 4-POT-SCM/S - Panel feed-through terminal block





3056941

<https://www.phoenixcontact.com/de/produkte/3056941>

Approvals

To download certificates, visit the product detail page: <https://www.phoenixcontact.com/de/produkte/3056941>

 CSA Approval ID: 13631				
	Nominal voltage U_N	Nominal current I_N	Cross section AWG	Cross section mm^2
Use group B	300 V	30 A	24 - 10	-
Use group C	300 V	30 A	24 - 10	-
Use group D	600 V	5 A	24 - 10	-

 cULus Recognized Approval ID: E60425-20100423				
	Nominal voltage U_N	Nominal current I_N	Cross section AWG	Cross section mm^2
Use group B	300 V	30 A	24 - 10	-
Use group C	300 V	30 A	24 - 10	-
Use group D	600 V	5 A	24 - 10	-

PW 4-POT-SCM/S - Panel feed-through terminal block



3056941

<https://www.phoenixcontact.com/de/produkte/3056941>

Classifications

ECLASS

ECLASS-11.0	27141134
ECLASS-13.0	27141134
ECLASS-12.0	27141134

ETIM

ETIM 9.0	EC001283
----------	----------

UNSPSC

UNSPSC 21.0	39121400
-------------	----------

PW 4-POT-SCM/S - Panel feed-through terminal block



3056941

<https://www.phoenixcontact.com/de/produkte/3056941>

Environmental product compliance

EU RoHS

Fulfills EU RoHS substance requirements	Yes, No exemptions
-----------------------------------------	--------------------

China RoHS

Environment friendly use period (EFUP)	EFUP-E
	No hazardous substances above the limits

EU REACH SVHC

REACH candidate substance (CAS No.)	No substance above 0.1 wt%
-------------------------------------	----------------------------

Phoenix Contact 2024 © - all rights reserved
<https://www.phoenixcontact.com>

PHOENIX CONTACT Deutschland GmbH
Flachmarktstraße 8
D-32825 Blomberg
+49 52 35/3-1 20 00
info@phoenixcontact.de