

CBMC E4 24DC/1-10A S-R - Electronic circuit breaker



1065729

<https://www.phoenixcontact.com/de/produkte/1065729>

Please be informed that the data shown in this PDF document is generated from our online catalog. Please find the complete data in the user documentation. Our general terms of use for downloads are valid.



Multi-channel electronic circuit breaker for protecting four loads at 24 V DC in the event of overload or short circuit. With status output, reset input, and electronic locking of the set nominal currents. For installation on DIN rails.

Your advantages

- Easy device replacement without replanning, thanks to compact design and options for individual adjustments
- Circuits can be adjusted without any tools by means of one single pushable LED button
- Enhanced diagnostic and control options, thanks to integrated status output and reset input
- Reliable protection against unintentional adjustment of current values, thanks to electronic locking
- Status LEDs in traffic light colors enable instantaneous determination of operating states

Commercial data

Item number	1065729
Packing unit	1 pc
Minimum order quantity	1 pc
Sales key	L1 - Schutzschalter
Product key	CLA152
Catalog page	Page 375 (C-4-2019)
GTIN	4055626728810
Weight per piece (including packing)	140,75 g
Weight per piece (excluding packing)	123,61 g
Customs tariff number	85362010
Country of origin	DE

Technical data

Notes

General

Note	Repeated hard short circuits can reduce the melting integral of the integrated backup fuse.
------	---

Product properties

Type	DIN rail module, one-piece
Product type	Device circuit breakers
Product family	CBMC
Number of positions	1
No. of channels	4

Insulation characteristics

Protection class	III
Pollution degree	2

Electrical properties

General

Operating voltage	18 V DC ... 30 V DC
Rated voltage	24 V DC
Rated current I_N	max. 40 A DC (IN+) max. 40 A DC (per terminal position when bridging additional devices via IN+)
Rated current I_N	1 / 2 / 3 / 4 / 5 / 6 / 7 / 8 / 9 / 10 A DC (adjustable per output channel)
Rated current (pre-adjusted)	4 A
Rated surge voltage	0.5 kV
Tripping method	E (electronic)
Feedback resistance	max. 35 V DC
Required backup fuse	Only required if I_{max} of the power supply > the short-circuit switching capacity. Integrated failsafe element.
Short-circuit switching capacity	300 A
Dielectric strength	max. 35 V DC (Load circuit)
Fuse	electronic
Efficiency	> 99 %
Closed circuit current I_0	typ. 25 mA
Power dissipation	typ. 0.6 W (No-load operation) < 9 W (Nominal operation)
Module initialization time	1.6 s
Waiting time after switch off of a channel	5 s (at overload / short circuit)
Measuring tolerance I	± 15 % 24 A DC (at 60 °C)

CBMC E4 24DC/1-10A S-R - Electronic circuit breaker



1065729

<https://www.phoenixcontact.com/de/produkte/1065729>

Temperature derating	28 A DC (at 54 °C)
	32 A DC (at 47 °C)
	36 A DC (at 41 °C)
	40 A DC (at 35 °C)
MTBF (IEC 61709, SN 29500)	8403361 h (at 25 °C with 21 % load)
	3067484 h (at 40 °C with 34.25% load)
	534188 h (at 35 °C with 100 % load)
Fail-safe element	15 A DC (per output channel)

Load circuit

Shutdown time	≤ 10 ms (for short circuit > 2.0 x I _N)
	1 s (1.2 ... 2.0 x I _N)
Undervoltage switch-off	≤ 17.8 V DC (active)
	≥ 18.8 V DC (inactive)
Overvoltage switch-off	≥ 30.5 V DC (active)
	≤ 29.5 V DC (inactive)
Max. capacitive load	45000 µF (Depending on the current setting and the short-circuit current available)

Reset

Input voltage range	7 V DC ... 30 V DC (Reset with falling edge)
Current consumption	typ. 0.4 mA (at 24 V DC)
Pulse length	≥ 50 ms (High)
	≥ 50 ms (Low)
Voltage	< 5 V DC (Low state)
	> 8 V DC (High state)
Stripping length	10 mm
Conductor cross section rigid	0.2 mm ² ... 2.5 mm ²
Conductor cross section AWG	24 ... 12
Conductor cross section, flexible, with ferrule, with plastic sleeve	0.25 mm ² ... 1.5 mm ²
Conductor cross section flexible, with ferrule without plastic sleeve	0.25 mm ² ... 2.5 mm ²

Status output

Output voltage	24 V DC
Output current	max. 0.04 A (Short-circuit-proof)
Stripping length	10 mm
Conductor cross section rigid	0.2 mm ² ... 2.5 mm ²
Conductor cross section AWG	24 ... 12
Conductor cross section, flexible, with ferrule, with plastic sleeve	0.25 mm ² ... 1.5 mm ²
Conductor cross section flexible, with ferrule without plastic sleeve	0.25 mm ² ... 2.5 mm ²

Connection data

Main circuit IN+

Connection method	Push-in connection
-------------------	--------------------

CBMC E4 24DC/1-10A S-R - Electronic circuit breaker



1065729

<https://www.phoenixcontact.com/de/produkte/1065729>

Stripping length	15 mm
Conductor cross section rigid	0.2 mm ² ... 10 mm ²
Conductor cross section AWG	24 ... 8
Conductor cross section, flexible, with ferrule, with plastic sleeve	0.25 mm ² ... 4 mm ²
Conductor cross section flexible, with ferrule without plastic sleeve	0.25 mm ² ... 6 mm ²

Main circuit IN-

Connection method	Push-in connection
Stripping length	10 mm
Conductor cross section rigid	0.2 mm ² ... 2.5 mm ²
Conductor cross section AWG	24 ... 12
Conductor cross section, flexible, with ferrule, with plastic sleeve	0.25 mm ² ... 1.5 mm ²
Conductor cross section flexible, with ferrule without plastic sleeve	0.25 mm ² ... 2.5 mm ²

Main circuit OUT+

Connection method	Push-in connection
Stripping length	10 mm
Conductor cross section rigid	0.2 mm ² ... 2.5 mm ²
Conductor cross section AWG	24 ... 12
Conductor cross section, flexible, with ferrule, with plastic sleeve	0.25 mm ² ... 1.5 mm ²
Conductor cross section flexible, with ferrule without plastic sleeve	0.25 mm ² ... 2.5 mm ²

Signaling

Channel LED off	off (Channel switched off)
Channel LED yellow	lit (Channel switched on, channel load > 80%)
	flashing (Programming mode active)
Channel LED green	lit (Channel switched on)
Channel LED red	lit (Channel switched off, over- or undervoltage active)
	ON temporarily (Channel switched off, 5 s cool-down phase, overload or short-circuit release)
	flashing (Channel switched off, ready to be switched back on, overload or short-circuit release)
	two flashes (Channel switched off, device total current limit 40 A exceeded)

Dimensions

Dimensional drawing	
Width	36 mm
Height	90 mm

1065729

<https://www.phoenixcontact.com/de/produkte/1065729>

Depth	98 mm (incl. DIN rail 7.5 mm)
-------	-------------------------------

Material specifications

Color	light grey (RAL 7035)
Material	PC
	PA 6.6
	PA 6.3T
	POM
Flammability rating according to UL 94	V-0

Environmental and real-life conditions

Ambient conditions

Degree of protection	IP20
Ambient temperature (operation)	-25 °C ... 60 °C
Ambient temperature (storage/transport)	-40 °C ... 70 °C
Altitude	≤ 3000 m up to 52 °C (amsl)
	≤ 4000 m up to 46 °C (amsl)
Humidity test	96 h, 95 % RH, 40 °C
Shock (operation)	30g (IEC 60068-2-27, Test Ea)
Vibration (operation)	10 Hz ... 57.6 Hz (Amplitude ±0.35 mm; in accordance with IEC 60068-2-6, Test Fc)
	57.6 Hz ... 150 Hz (Acceleration 5g; in accordance with IEC 60068-2-6, Test Fc)

Approvals

UL approval

Identification	UL/C-UL Listed UL 508
	UL Recognized UL 2367

Standards and regulations

Standards/specifications	EN 61000-6-2
Note	EMC – Immunity for industrial areas
Standards/specifications	EN 61000-6-3
Note	EMC – Emission for residential, business and commercial properties and small operations
Standards/specifications	EN 60068-2-6
Note	Environmental influences – Vibrations (sinusoidal)
Standards/specifications	EN 60068-2-27
Note	Environmental influences – Shocks
Standards/specifications	EN 60068-2-78
Note	Environmental influences – Moisture and heat, constant
Standards/specifications	EN 50178
Note	Equipping power installations with electronic equipment

CBMC E4 24DC/1-10A S-R - Electronic circuit breaker



1065729

<https://www.phoenixcontact.com/de/produkte/1065729>

Mounting

Mounting type	DIN rail: 35 mm
---------------	-----------------

Drawings

Block diagram

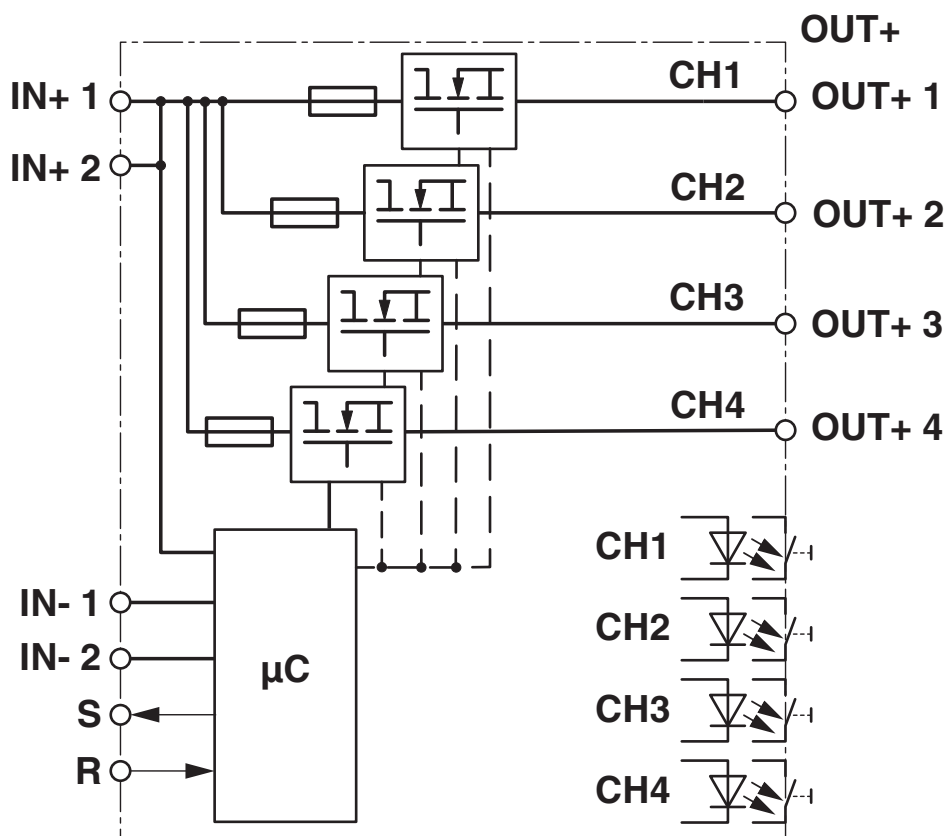

Diagram

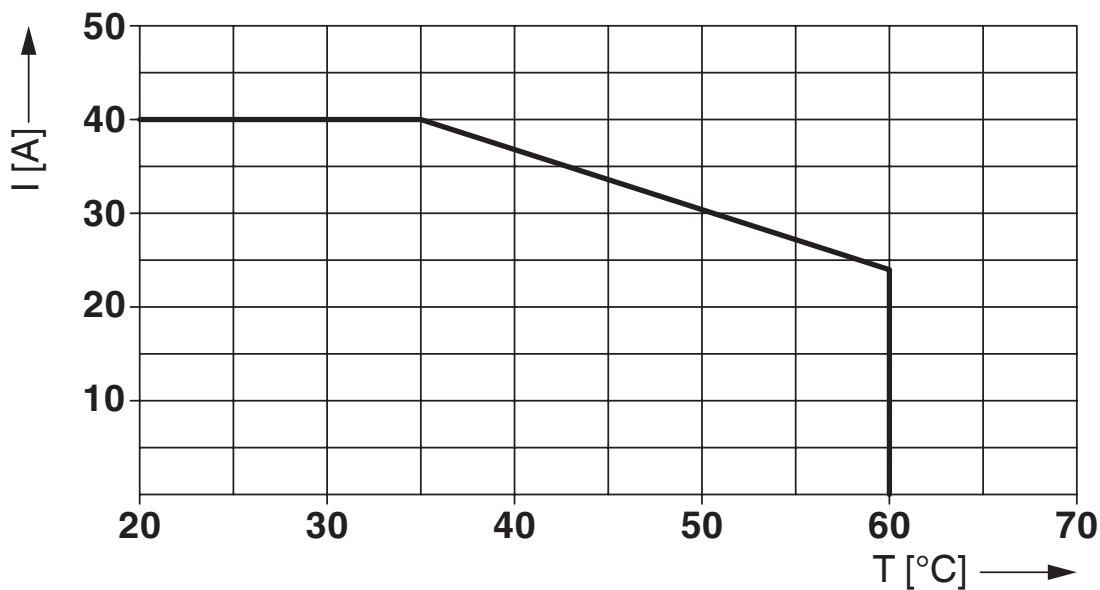

Max. permissible current in relation to the ambient temperature

CBMC E4 24DC/1-10A S-R - Electronic circuit breaker



1065729

<https://www.phoenixcontact.com/de/produkte/1065729>

Dimensional drawing

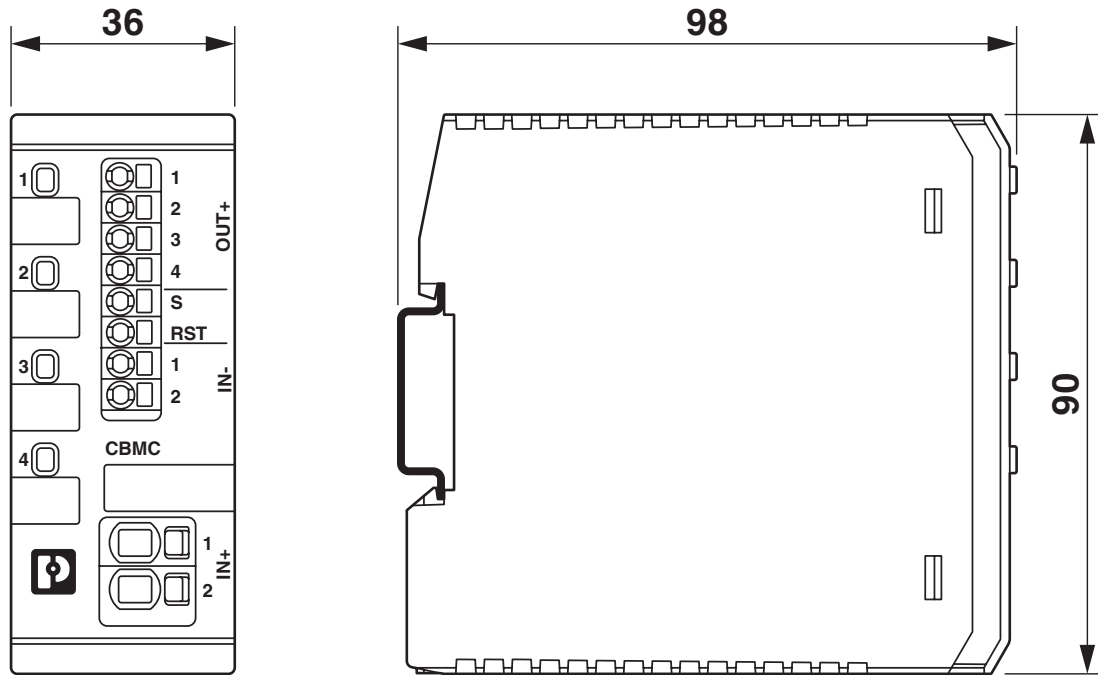

Diagram

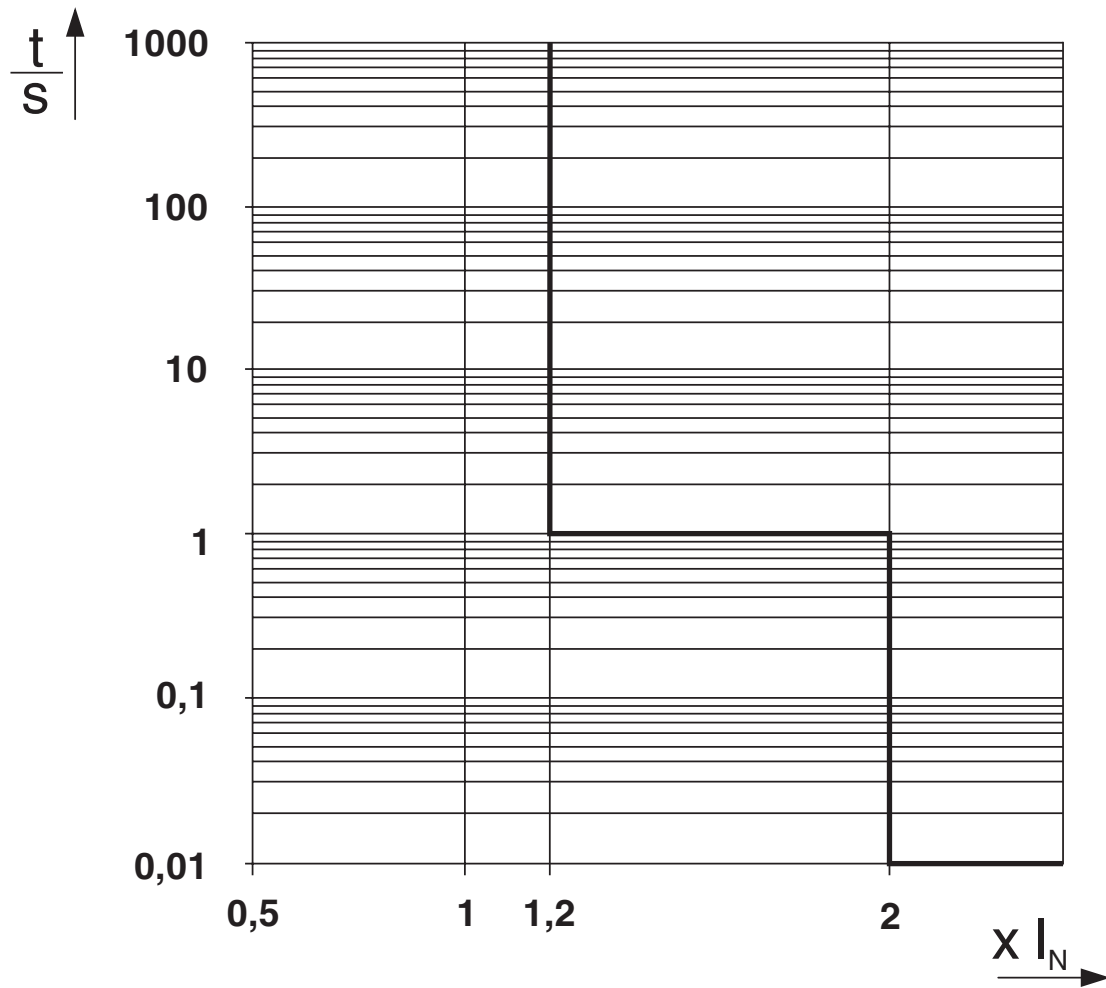

Trigger characteristic in the DC range

CBMC E4 24DC/1-10A S-R - Electronic circuit breaker



1065729

<https://www.phoenixcontact.com/de/produkte/1065729>

Product drawing

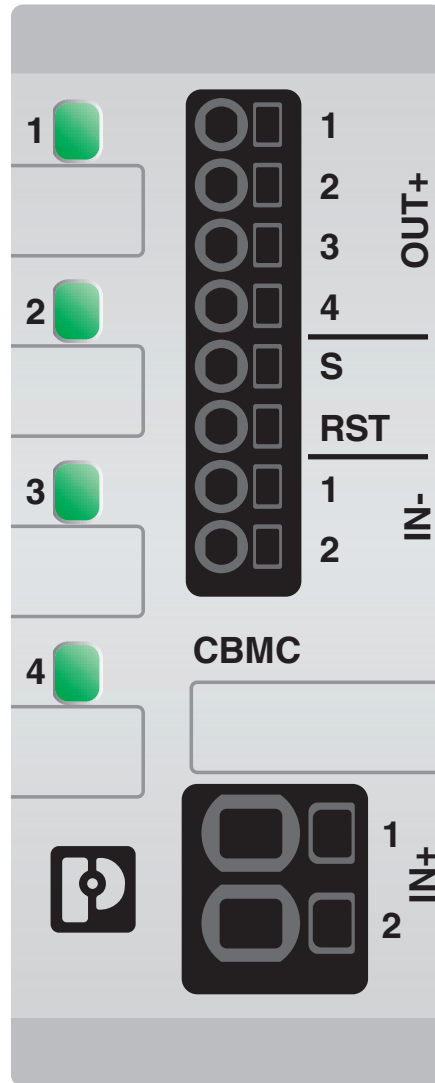

1065729

<https://www.phoenixcontact.com/de/produkte/1065729>

Approvals

To download certificates, visit the product detail page: <https://www.phoenixcontact.com/de/produkte/1065729>



UL Recognized

Approval ID: FILE E 317172



UL Listed

Approval ID: FILE E 123528



cUL Listed

Approval ID: FILE E 123528

cULus Listed

1065729

<https://www.phoenixcontact.com/de/produkte/1065729>

Classifications

ECLASS

ECLASS-11.0	27140401
ECLASS-12.0	27140401
ECLASS-13.0	27140401

ETIM

ETIM 9.0	EC003538
----------	----------

UNSPSC

UNSPSC 21.0	39121400
-------------	----------

1065729

<https://www.phoenixcontact.com/de/produkte/1065729>

Environmental product compliance

REACH SVHC	Perfluorobutane sulfonic acid (PFBS) and its salts
	Lead 7439-92-1
China RoHS	Environmentally Friendly Use Period = 50 years
	For information on hazardous substances, refer to the manufacturer's declaration available under "Downloads"

1065729

<https://www.phoenixcontact.com/de/produkte/1065729>

Accessories

EML (10X7)R - Label

0816663

<https://www.phoenixcontact.com/de/produkte/0816663>



Label, Roll, white, unlabeled, can be labeled with: THERMOMARK E.300 (D)/600 (D), THERMOMARK ROLL 2.0, THERMOMARK ROLL, THERMOMARK ROLL X1, THERMOMARK ROLLMASTER 300/600, THERMOMARK X1.2, mounting type: adhesive, lettering field size: 10 x 7 mm, Number of individual labels: 10000

EML-ESD (20X7)R - Equipment marking

0830567

<https://www.phoenixcontact.com/de/produkte/0830567>



Equipment marking, Roll, white, unlabeled, can be labeled with: THERMOMARK E.300 (D)/600 (D), THERMOMARK ROLL 2.0, THERMOMARK ROLL, THERMOMARK ROLL X1, THERMOMARK ROLLMASTER 300/600, THERMOMARK X1.2, mounting type: adhesive, lettering field size: 20 x 7 mm, Number of individual labels: 4000

CBMC E4 24DC/1-10A S-R - Electronic circuit breaker



1065729

<https://www.phoenixcontact.com/de/produkte/1065729>

QUINT4-PS/1AC/24DC/10 - Power supply unit

2904601

<https://www.phoenixcontact.com/de/produkte/2904601>



Primary-switched QUINT POWER power supply with free choice of output characteristic curve, SFB (selective fuse breaking) technology, and NFC interface, input: 1-phase, output: 24 V DC/10 A

QUINT4-PS/1AC/24DC/20 - Power supply unit

2904602

<https://www.phoenixcontact.com/de/produkte/2904602>



Primary-switched QUINT POWER power supply with free choice of output characteristic curve, SFB (selective fuse breaking) technology, and NFC interface, input: 1-phase, output: 24 V DC/20 A

CBMC E4 24DC/1-10A S-R - Electronic circuit breaker



1065729

<https://www.phoenixcontact.com/de/produkte/1065729>

QUINT4-PS/3AC/24DC/10 - Power supply unit

2904621

<https://www.phoenixcontact.com/de/produkte/2904621>



Primary-switched QUINT POWER power supply with free choice of output characteristic curve, SFB (selective fuse breaking) technology, and NFC interface, input: 3-phase, output: 24 V DC/10 A

QUINT4-PS/3AC/24DC/20 - Power supply unit

2904622

<https://www.phoenixcontact.com/de/produkte/2904622>



Primary-switched QUINT POWER power supply with free choice of output characteristic curve, SFB (selective fuse breaking) technology, and NFC interface, input: 3-phase, output: 24 V DC/20 A

CBMC E4 24DC/1-10A S-R - Electronic circuit breaker



1065729

<https://www.phoenixcontact.com/de/produkte/1065729>

TRIO-PS-2G/1AC/24DC/10 - Power supply unit

2903149

<https://www.phoenixcontact.com/de/produkte/2903149>



Primary-switched TRIO POWER power supply with push-in connection for DIN rail mounting, input: single phase, output: 24 V DC/10 A

TRIO-PS-2G/1AC/24DC/20 - Power supply unit

2903151

<https://www.phoenixcontact.com/de/produkte/2903151>



Primary-switched TRIO POWER power supply with push-in connection for DIN rail mounting, input: single-phase, output: 24 V DC/20 A

CBMC E4 24DC/1-10A S-R - Electronic circuit breaker



1065729

<https://www.phoenixcontact.com/de/produkte/1065729>

TRIO-PS-2G/3AC/24DC/5 - Power supply unit

2903153

<https://www.phoenixcontact.com/de/produkte/2903153>



Primary-switched TRIO POWER power supply with push-in connection for DIN rail mounting, input: 3-phase, output: 24 V DC/5 A

TRIO-PS-2G/3AC/24DC/10 - Power supply unit

2903154

<https://www.phoenixcontact.com/de/produkte/2903154>



Primary-switched TRIO POWER power supply with push-in connection for DIN rail mounting, input: 3-phase, output: 24 V DC/10 A

CBMC E4 24DC/1-10A S-R - Electronic circuit breaker



1065729

<https://www.phoenixcontact.com/de/produkte/1065729>

TRIO-PS-2G/3AC/24DC/20 - Power supply unit

2903155

<https://www.phoenixcontact.com/de/produkte/2903155>



Primary-switched TRIO POWER power supply with push-in connection for DIN rail mounting, input: 3-phase, output: 24 V DC/20 A

TRIO-PS-2G/3AC/24DC/40 - Power supply unit

2903156

<https://www.phoenixcontact.com/de/produkte/2903156>



Primary-switched TRIO power supply for DIN rail mounting, input: 3-phase, output: 24 V DC/40 A, dynamic boost, tool-free fast connection technology for solid and stranded conductors with ferrule

Phoenix Contact 2024 © - all rights reserved
<https://www.phoenixcontact.com>

PHOENIX CONTACT Deutschland GmbH
Flachsmarktstraße 8
D-32825 Blomberg
+49 52 35/3-1 20 00
info@phoenixcontact.de