

Double socket - EO-AB/UT/LED/DUO/V/GFI/20



1263627

<https://www.phoenixcontact.com/de/produkte/1263627>

Please be informed that the data shown in this PDF document is generated from our Online Catalog. Please find the complete data in the user documentation. Our General Terms of Use for Downloads are valid.



Double socket, Pin connector pattern type AB 20A, Screw connection, gray, for mounting on a DIN rail in the service interface or direct mounting, 125 V AC, 20 A, -20 °C, 60 °C, UL 508

Commercial Data

Item number	1263627
Packing unit	1 pc
Minimum order quantity	1 pc
Sales Key	H1 - Stromversorgungen
Product Key	BE7623
GTIN	4063151375379
Weight per Piece (including packing)	286,3 g
Weight per Piece (excluding packing)	286,3 g
Customs tariff number	85366990
Country of origin	PL

Double socket - EO-AB/UT/LED/DUO/V/GFI/20

1263627

<https://www.phoenixcontact.com/de/produkte/1263627>

Technical Data

Product properties

Product type	Socket
Response time	25 ms (6 mA)

Electrical properties

Nominal voltage U_N	125 V AC (60 Hz)
Nominal current I_N	20 A

LED signaling

Status display	Yes
----------------	-----

Dimensions

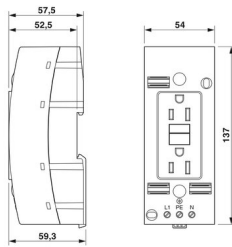
Dimensional drawing	
Width	54 mm
Height	137 mm
Depth	57.5 mm

Material specifications

Color	gray
Flammability rating according to UL 94	V2
Insulating material	PA
Contact material	CuZn37

Connector

Type of plug	Pin connector pattern type AB 20A
--------------	-----------------------------------

Environmental and real-life conditions

Ambient conditions

Degree of protection	IP20
Ambient temperature (operation)	-20 °C ... 60 °C

Standards and regulations

Standards

Standards/regulations	UL 508
-----------------------	--------

Double socket - EO-AB/UT/LED/DUO/V/GFI/20



1263627

<https://www.phoenixcontact.com/de/produkte/1263627>

Mounting

Mounting type	
---------------	--

	for mounting on a DIN rail in the service interface or direct mounting
--	--

Double socket - EO-AB/UT/LED/DUO/V/GFI/20



1263627

<https://www.phoenixcontact.com/de/produkte/1263627>

Drawings

Dimensional drawing

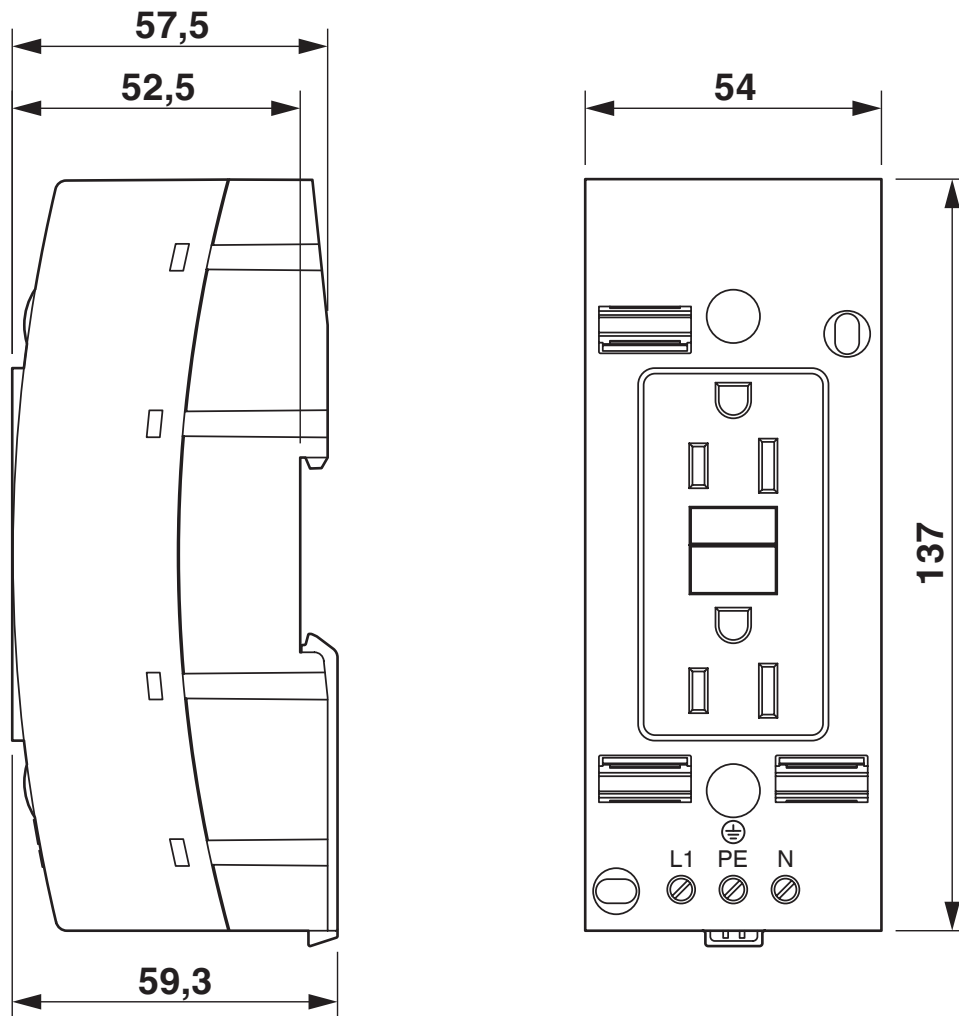

Double socket - EO-AB/UT/LED/DUO/V/GFI/20

1263627

<https://www.phoenixcontact.com/de/produkte/1263627>

Circuit diagram

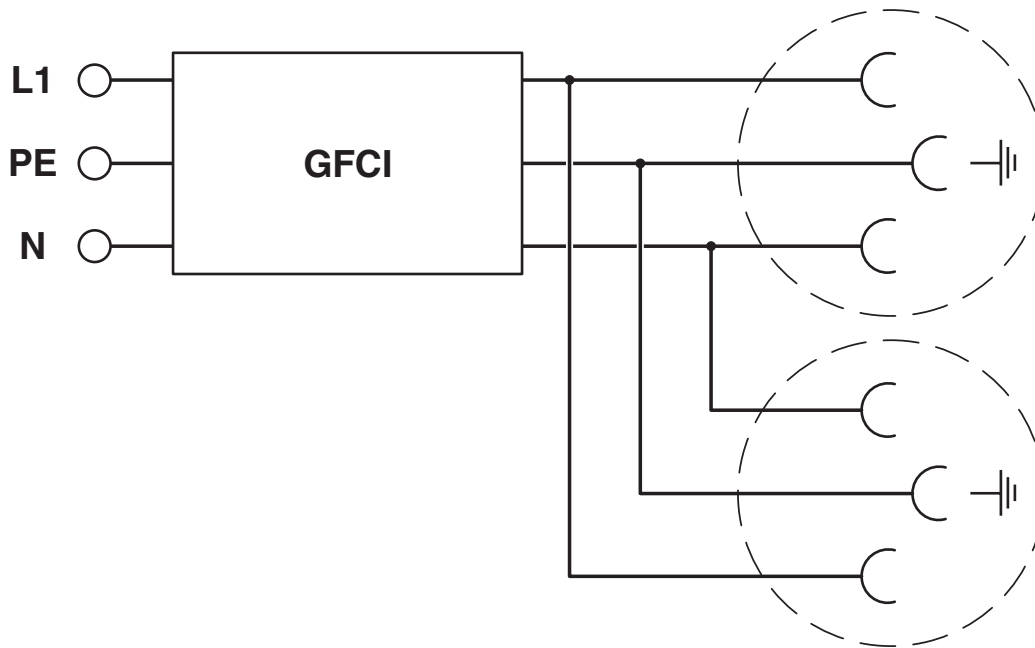

Double socket - EO-AB/UT/LED/DUO/V/GFI/20



1263627

<https://www.phoenixcontact.com/de/produkte/1263627>

Approvals

	cULus Recognized Approval ID: E255026			
	Nominal Voltage U_N	Nominal Current I_N	Cross Section AWG	Cross Section mm^2
	120 V	20 A	24 - 12	-

Double socket - EO-AB/UT/LED/DUO/V/GFI/20



1263627

<https://www.phoenixcontact.com/de/produkte/1263627>

Classifications

ECLASS

ECLASS-11.0

27142305

ETIM

ETIM 7.0

EC001663

UNSPSC

UNSPSC 21.0

39121406

Double socket - EO-AB/UT/LED/DUO/V/GFI/20



1263627

<https://www.phoenixcontact.com/de/produkte/1263627>

Environmental Product Compliance

REACH SVHC

Lead 7439-92-1

Phoenix Contact 2022 © - all rights reserved

<https://www.phoenixcontact.com>

PHOENIX CONTACT Deutschland GmbH

Flachmarktstraße 8

D-32825 Blomberg

+49 52 35/3-1 20 00

info@phoenixcontact.de