

## Assembly adapters - FL EPA WMS - 2701134

Please be informed that the data shown in this PDF Document is generated from our Online Catalog. Please find the complete data in the user's documentation. Our General Terms of Use for Downloads are valid (<http://phoenixcontact.com/download>)

Set for mounting devices with EPA design to wall or mast, including mast clips for a diameter of 25 - 85 mm, can be moved on two axes for optimum alignment, stainless steel



### Key Commercial Data

Packing unit	1 pc
GTIN	 4 046356 712385
GTIN	4046356712385
Weight per Piece (excluding packing)	303.500 g
Weight per piece (including packing)	303.700 g
Custom tariff number	85177000
Country of origin	Germany
Sales Key	M2 - Network Techn.

### Technical data

Product type	Assembly adapter
--------------	------------------

### Drawings

Schematic diagram

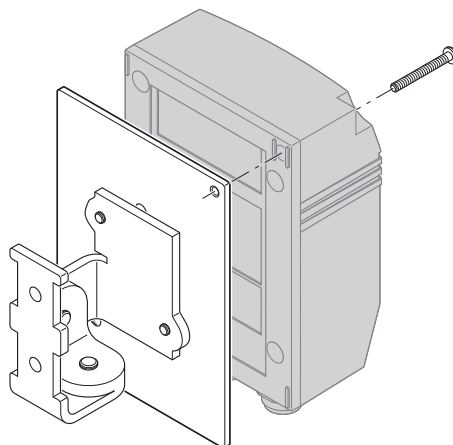

## Assembly adapters - FL EPA WMS - 2701134

### Classifications

#### eCl@ss

eCl@ss 4.0	27240400
eCl@ss 4.1	27240400
eCl@ss 5.0	19030100
eCl@ss 5.1	19030100
eCl@ss 6.0	27379200
eCl@ss 7.0	27379217
eCl@ss 9.0	27379217

#### ETIM

ETIM 3.0	EC001423
ETIM 4.0	EC002032
ETIM 6.0	EC002032
ETIM 7.0	EC002032

#### UNSPSC

UNSPSC 6.01	43172710
UNSPSC 7.0901	43223108
UNSPSC 11	43172710
UNSPSC 12.01	43223108
UNSPSC 13.2	27113201
UNSPSC 18.0	27113201
UNSPSC 19.0	27113201
UNSPSC 20.0	27113201
UNSPSC 21.0	27113201