

# FLT-CP-PLUS-3S-350

Order No.: 2882640



<http://catalog.phoenixcontact.net/phoenix/treeViewClick.do?UID=2882640>

Pluggable lighting current arrester, in acc. with type 1/class I/B for 3-phase power supply networks with combined PE and N (L1, L2, L3, PE, N).



Commercial data	
EAN	 4 046356 098243
sales group	J010
Pack	1 Pcs.
Customs tariff	85363010
Gross weight in pieces	1.7377 KG
Net weight per piece	1.3947 KG
Catalog page information	Page 16 (TT-2011)

### Product notes

WEEE/RoHS-compliant since:  
05/09/2006



<http://www.download.phoenixcontact.com>  
Please note that the data given here has been taken from the online catalog. For comprehensive information and data, please refer to the user documentation. The General Terms and Conditions of Use apply to Internet downloads.

Technical data	
<b>Standards</b>	
IEC power supply system	TT
	TN-S
Housing material	PBT
Inflammability class according to UL 94	V0

Color	gray
Standards for air and creepage distances	EN 60664-1
	IEC 60664-1
	IEC 61643-11
Degree of protection	IP20
Mounting type	DIN rail: 35 mm
Design	DIN rail module, two-section, divisible
Number of positions	4
Ambient temperature (operation)	-40 °C ... 80 °C
Message: Surge protection fault	Optical, remote indicator contact
Direction of action	3L-N & N-PE
Width	142.8 mm
Height	97 mm
Depth	71.5 mm
Pitch unit	8 Div.

#### Protective circuit

IEC category	I
	T1
EN type	T1
Lightning protection class	I /100 kA (TT, TN-C-S)
Nominal voltage $U_N$	240 V AC (230/400 V AC ... 240/415 V AC)
Arrester rated voltage $U_C$ (L-N)	350 V AC
Arrester rated voltage $U_C$ (N-PE)	350 V AC
$U_T$ (TOV-proof)	415 V AC (5 s)
	1200 V AC (200 ms / N-PE)
Nominal frequency $f_N$	50 Hz (60 Hz)
Nominal load current $I_L$	125 A ( $\leq 55^\circ\text{C}$ )
Ground conductor current $I_{PE}$	$\leq 5 \mu\text{A}$
Standby power consumption $P_C$	$\leq 5 \text{ mVA}$
Nominal discharge surge current $I_n$ (8/20) $\mu\text{s}$ (L-N)	25 kA
Nominal discharge surge current $I_n$ (8/20) $\mu\text{s}$ (N-PE)	100 kA
Lightning test current (10/350) $\mu\text{s}$ , charge	50 As
Lightning test current (10/350) $\mu\text{s}$ , specific energy	2.50 MJ/ $\Omega$
Lightning test current (10/350) $\mu\text{s}$ , peak value $I_{imp}$	100 kA

Lightning test current (10/350) $\mu$ s, charge	12.5 As
Lightning test current (10/350) $\mu$ s, specific energy	160.00 kJ/ $\Omega$ (L-N)
Lightning test current (10/350) $\mu$ s, peak value $I_{imp}$	25 kA (per channel L-N)
Impulse operate voltage at 6 kV (1.2/50) $\mu$ s (N-PE)	$\leq 1.5$ kV
Protection level $U_p$ (L-N)	$\leq 1.5$ kV
Protection level $U_p$ (L-PE)	$\leq 2.5$ kV
Protection level $U_p$ (N-PE)	$\leq 1.5$ kV
Response time (L-N)	$\leq 100$ ns
Response time (L-PE)	$\leq 100$ ns
Response time (N-PE)	$\leq 100$ ns
Max. required backup fuse with branch wiring	315 A (gL/gG)
Max. required backup fuse with V-type through wiring	125 A (gL/gG)
Recommended backup fuse maximum	160 A (gL/gG, 125 A with serial through wiring)
Short-circuit resistance $I_p$ with max. backup fuse (effective)	50 kA
Short-circuit current self-quenching	100 A (effective (N-PE))
Follow current quenching capacity $I_f$ (L-N)	50 kA (264 V AC) 25 kA (350 V AC)
Follow current quenching capacity $I_f$ (N-PE)	100 A

#### Connection, protective circuit

Connection method	Screw terminal blocks
Connection type IN	Biconnect screw terminal block
Connection type OUT	Biconnect screw terminal block
Connection method	Biconnect terminal block
Screw thread	M5
Tightening torque	4.5 Nm
Stripping length	18 mm
Conductor cross section stranded min.	2.5 mm <sup>2</sup>
Conductor cross section stranded max.	25 mm <sup>2</sup>
Conductor cross section solid min.	2.5 mm <sup>2</sup>
Conductor cross section solid max.	35 mm <sup>2</sup>
Conductor cross section AWG/kcmil min.	13
Conductor cross section AWG/kcmil max	2

**Remote indicator contact**

Connection name	Remote fault indicator contact
Switching function	PDT contact
Connection method	Plug-in/screw connection via COMBICON
Screw thread	M2
Tightening torque	0.25 Nm
Stripping length	7 mm
Conductor cross section stranded min.	0.14 mm <sup>2</sup>
Conductor cross section stranded max.	1.5 mm <sup>2</sup>
Conductor cross section solid min.	0.14 mm <sup>2</sup>
Conductor cross section solid max.	1.5 mm <sup>2</sup>
Conductor cross section AWG/kcmil min.	28
Conductor cross section AWG/kcmil max	16
Maximum operating voltage U <sub>max</sub> AC	250 V AC
Maximum operating voltage U <sub>max</sub> DC	125 V DC
Max. operating current I <sub>max</sub>	1 A AC (inductive)
	1 A AC (ohmic)
	30 mA DC (inductive)
	200 mA DC (ohmic)
Min. permissible switching capacity	0.12 VA (12 V, 10 mA)

**Standards**

Standards/regulations	IEC 61643-1 2005
	EN 61643-11 2002
	EN 61643-11/A11 2007
	UL 1449 ed. 2

**Certificates / Approvals**



Certification

cULus Recognized, GOST, GL

Certifications applied for:

Certification Ex:

**Accessories**

Item	Designation	Description
<b>General</b>		
2859686	FLT-CP-N/PE-350-ST	Type 1 / Class I / B arrester (lightning arrester) replacement plug for path N-PE, can be combined with FLASHTRAB compact series of products.
2859913	FLT-CP-PLUS-350-ST	Type 1 / Class I / B arrester (lightning arrester) replacement plug for paths L-N and L-PEN, can be combined with FLASHTRAB compact series of products.

**Marking**

1051993	B-STIFT	Marker pen, for manual labeling of unprinted Zack strips, smear-proof and waterproof, line thickness 0.5 mm
2749589	ZBN 18,LGS:ERDE	Zack marker strip, Strip, white, labeled, Horizontal: Grounding symbol, Mounting type: Snap into tall marker groove, For terminal block width: 18 mm, Lettering field: 18 x 5 mm
2749576	ZBN 18,LGS:L1-N,ERDE	Zack marker strip, Strip, white, labeled, Horizontal: L1, L2, L3, N, GND, Mounting type: Snap into tall marker groove, For terminal block width: 18 mm, Lettering field: 18 x 5 mm
0800763	ZBN 18:SO/CMS	Zack marker strip, white, For terminal block width: 18 mm
2809128	ZBN 18:UNBEDRUCKT	Zack marker strip, Strip, white, Unlabeled, Can be labeled with: Plotter, Mounting type: Snap into tall marker groove, For terminal block width: 18 mm, Lettering field: 18 x 5 mm

**Drawings**

Application drawing

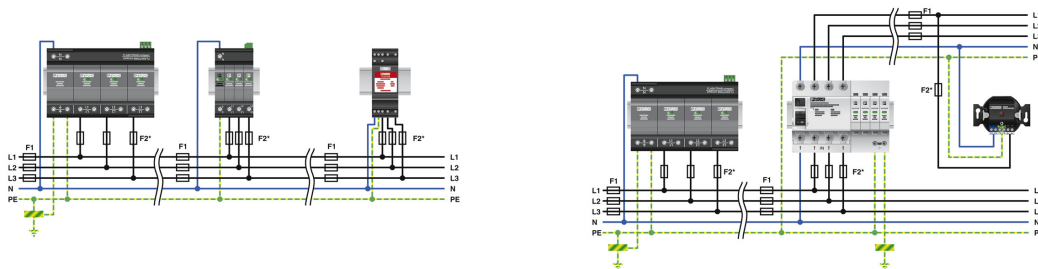

Dimensioned drawing

---

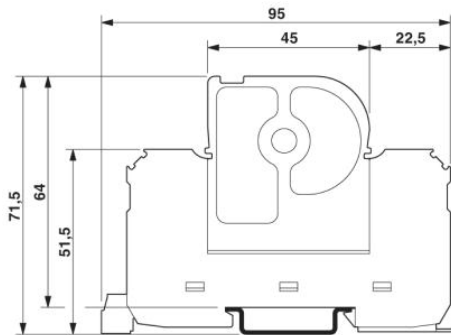

Circuit diagram

---

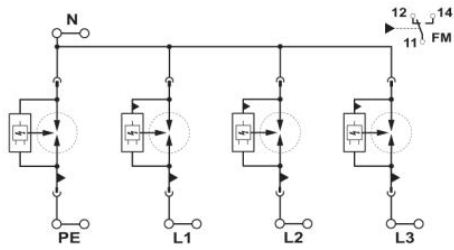

**Address**

PHOENIX CONTACT Deutschland GmbH  
Flachmarktstr. 8  
32825 Blomberg, Germany  
Phone +49 5235 3 12000  
Fax +49 5235 3 41200  
<http://www.phoenixcontact.de>



© 2012 Phoenix Contact  
Technical modifications reserved;